



## Non-isolated Quasi-Resonant Buck LED Power Switch

### FEATURES

- Integrated with 500V MOSFET
- No Auxiliary Winding Needed
- Quasi-Resonant for High Efficiency
- Built-in Thermal Foldback
- Built-in Charging Circuit for Fast Start-Up
- $\pm 4\%$  CC Regulation
- Very Low VDD Operation Current
- Built-in AC Line CC Compensation
- Build in Protections:
  - LED Short Protection
  - On-Chip Thermal Fold-back (OTP)
  - Cycle-by-Cycle Current Limiting
  - Leading Edge Blanking (LEB)
  - Pin Floating Protection
  - VDD UVLO
- Available with SOT23-3, SOP-8 and TO-92 Package

### GENERAL DESCRIPTION

DP9127 is a highly integrated power switch with Quasi-Resonant Buck (QR-Buck) constant current (CC) control for LED lighting applications.

DP9127 combines a 500V power MOSFET switch with a power controller in one chip. The IC also integrates high voltage startup/IC supply circuit and a novel transformer demagnetization circuit, which eliminates transformer auxiliary winding. The IC adopts Quasi-Resonant control for high efficiency.

DP9127 integrates functions and protections of Current Limit and Leading Edge Blanking, Under Voltage Lockout (UVLO), Cycle-by-cycle Current Limiting (OCP), Thermal Foldback (OTP), LED Short Protection, etc.

### APPLICATIONS

- LED Lighting

### TYPICAL APPLICATION CIRCUIT

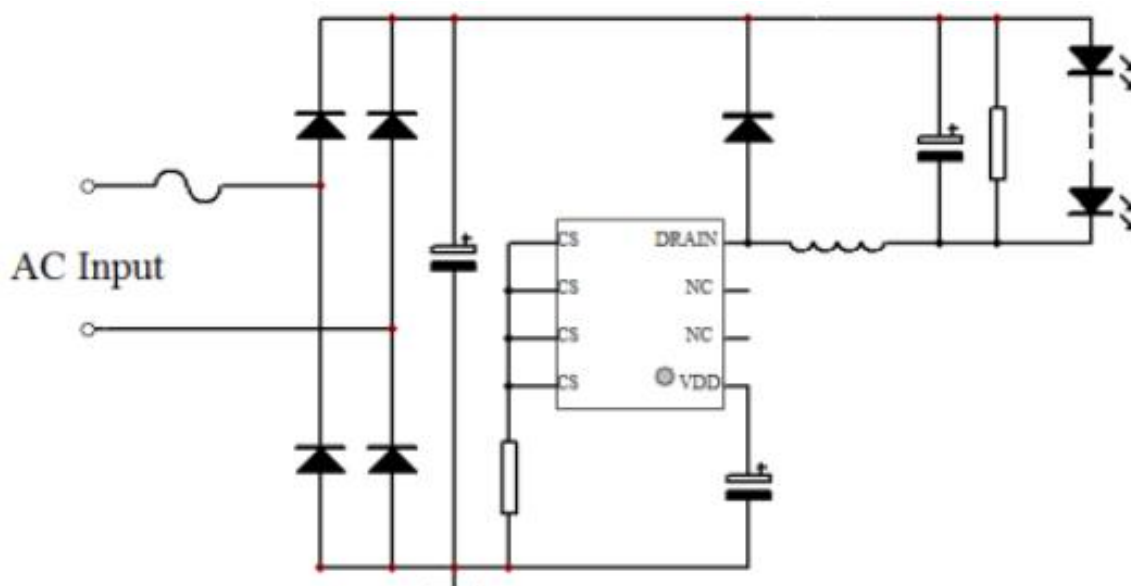



# DP9127

## Non-isolated Quasi-Resonant Buck LED Power Switch

### Pin Configuration

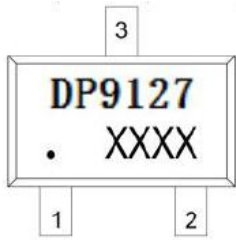

SOT23-3L

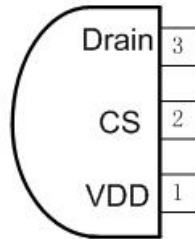

TO-92



SOP-8

### Output Power Table



Part Number	Package	Output Current for 90-265Vac		Output Current for 176-265Vac		Minimum Output Voltage
		36V output	72V output	150V output	200V output	
DP9127	SOT23-3L	130 mA	100mA	80 mA	70 mA	15V
DP9127	TO-92	150 mA	110 mA	90 mA	80 mA	
DP9127	SOP-8	160 mA	120 mA	100 mA	90 mA	

### Pin Description

SOP-8	TO-92	SOT23-3L	Pin Name	I/O	Description
4	3	1	Drain	P	Internal power MOSFET drain
1	1	2	VDD	P	Power Supply Pin of the Chip.
5,6,7,8	2	3	CS	P	The Ground of the IC. This pin is also used for peak current control.



**Ordering Information**

Part Number	Description
DP9127	SOT23-3L, Halogen free in T&R, 3000Pcs/Ree
DP9127	TO-92, Pb free in T&R, 2000Pcs/Box(Tape)
DP9127	SOP-8, Pb free in T&R, 4000Pcs/Reel

**Block Diagram**

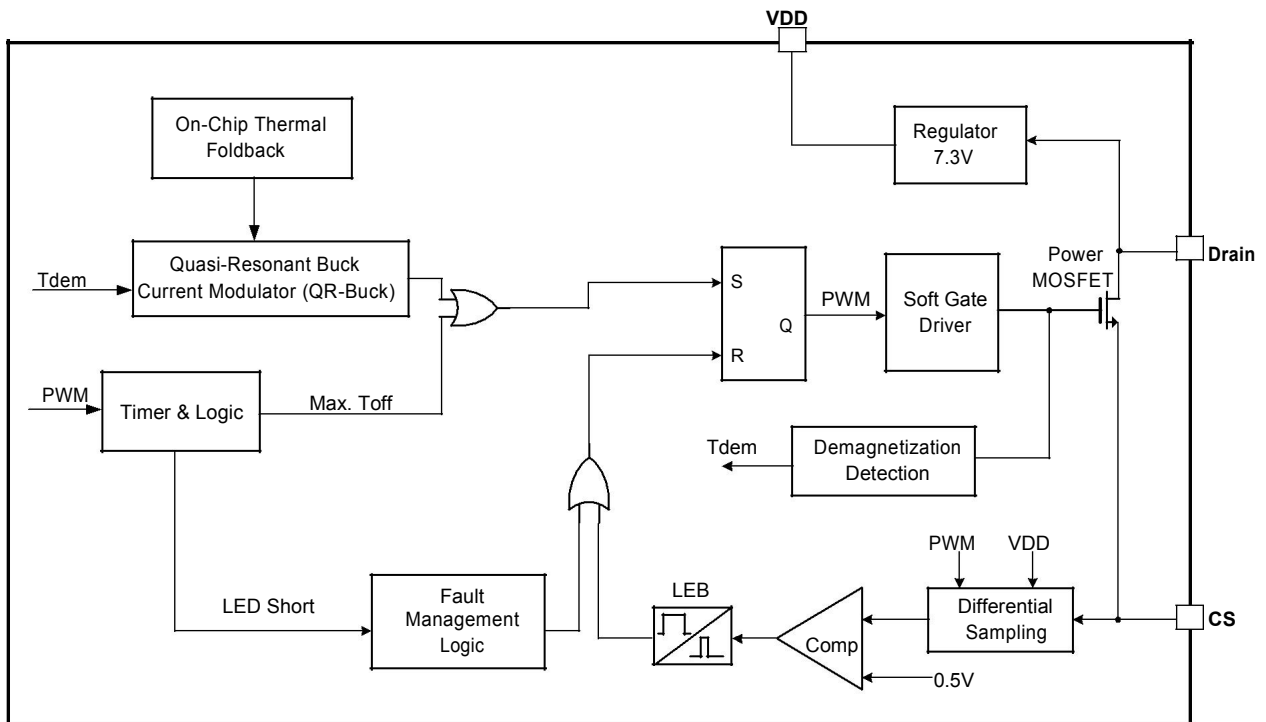



### Absolute Maximum Ratings (Note 1)

Parameter	Value	Unit
VDD DC Supply Voltage	8.5	V
Drain pin	-0.3 to 500	V
Package Thermal Resistance (SOP-8)	165	°C/W
Package Thermal Resistance (TO-92)	170	°C/W
Package Thermal Resistance (SOT23-3L)	260	°C/W
Maximum Junction Temperature	160	°C
Storage Temperature Range	-65 to 150	°C
Lead Temperature (Soldering, 10sec.)	260	°C
ESD Capability, HBM (Human Body Model)	3	kV
ESD Capability, MM (Machine Model)	250	V

### Recommended Operation Conditions (Note 2)

Parameter	Value	Unit
Operating Junction Temperature	-40 to 125	°C

### Electrical Characteristics (Ta = 25°C, If Not Otherwise Noted)

Symbol	Parameter	Test Conditions	Min	Typ.	Max	Unit
<b>Supply Voltage Section(VDD Pin)</b>						
I <sub>VDD_ST</sub>	Startup Current	VDD=6.5V		700		uA
I <sub>VDD_Op</sub>	Operation Current			140	260	uA
V <sub>DD_Op</sub>	VDD Operation Voltage		6.8	7.3	7.8	V
V <sub>DD_OFF</sub>	VDD Under Voltage Lockout Enter			5.3		V
<b>Timing Section</b>						
T <sub>on_max</sub>	Maximum On Time			32		us
T <sub>off_min</sub>	Minimum OFF Time			2.5		us
T <sub>off_max</sub>	Maximum OFF Time			300		us



# DP9127

## Non-isolated Quasi-Resonant Buck LED Power Switch

$T_{dem\_OVP}$	Off Time OVP Trigger Threshold			5		us
<b>Current Sense Input Section (CS Pin)</b>						
$T_{LEB}$	CS Input Leading Edge Blanking Time			500		ns
$V_{cs(max)}$	Current limiting threshold		490	500	510	mV
$T_{D\_OCP}$	Over Current Detection and Control Delay			100		ns
<b>Over Temperature Protection</b>						
$T_{SD}$	Thermal Foldback Trigger Point	(Note 3)		150		°C
<b>Power MOSFET Section (Drain Pin)</b>						
$V_{BR}$	Power MOSFET Drain Source Breakdown Voltage		500			V
$R_{dson}$	Static Drain-Source On Resistance	$I(Drain)=50mA$		15		ohm

**Note1.** Stresses listed as the above "Maximum Ratings" may cause permanent damage to the device. These are for stress ratings. Functional operation of the device at these or any other conditions beyond those indicated in the operational sections of the specifications is not implied. Exposure to maximum rating conditions for extended periods may remain possibility to affect device reliability.

**Note2.** The device is not guaranteed to function outside its operating conditions.

**Note3.** Guaranteed by design.



### Characterization Plots

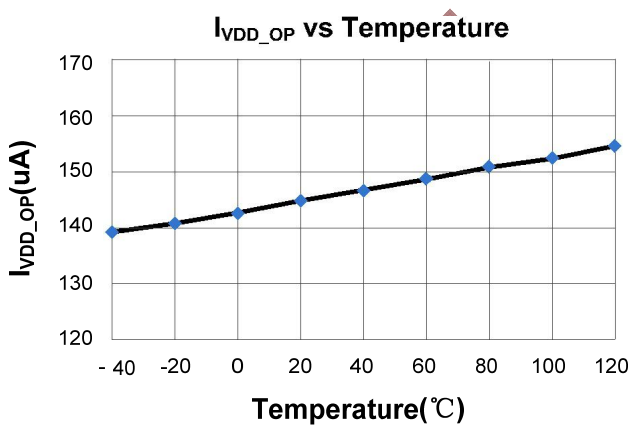
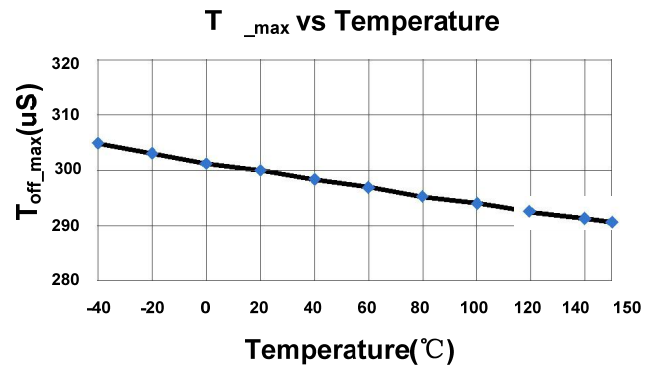
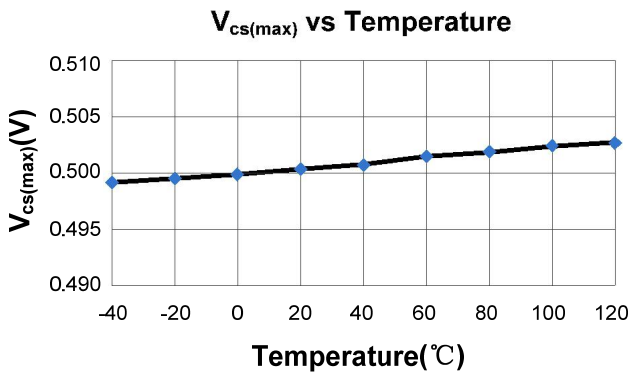
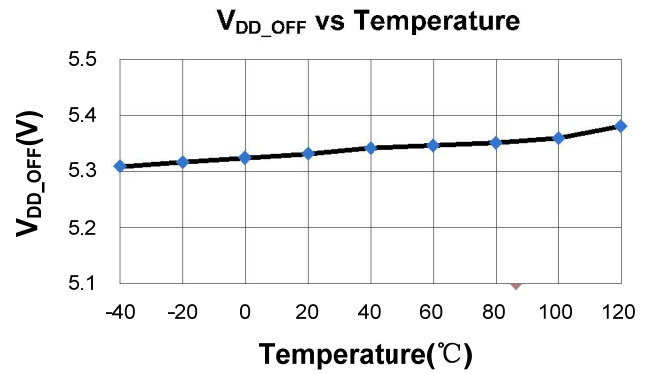
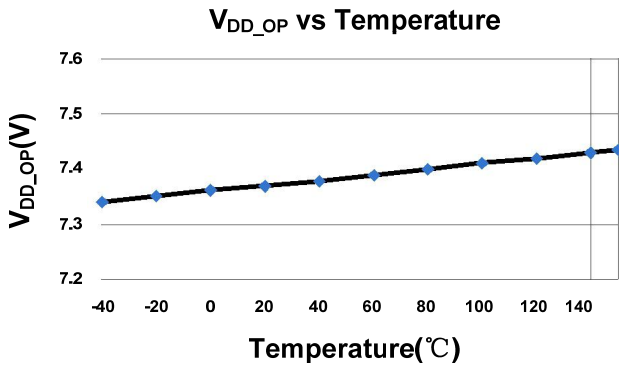



### Operation Description

DP9127 combines a high voltage power MOSFET switch with a power controller in one chip. The built-in high precision CC control with high level protection features makes it suitable for LED lighting applications.

- 7.3V Regulator**

In DP9127, the 7.3V regulator charges VDD hold-up capacitor to 7.3V by drawing a current from the voltage on the Drain pin, whenever the internal power MOSFET is off. When the power MOSFET is on, the charging device runs off of the energy stored in the VDD hold-up capacitor. Extremely low IC power consumption allows DP9127 to operate continuously from the current drawn from the Drain pin. A capacitor value about 1uF is sufficient for both high frequency decoupling and energy storage.

- Very Low Operation Current**

The operating current in DP9127 is as small as 140uA (typical). The small operating current results in higher efficiency and reduces the VDD hold-up capacitance requirement.

- Demagnetization Detection without Auxiliary Winding**

In DP9127, the transformer core demagnetization is detected by monitoring the coupling current flowing through the parasitic capacitor Crss between the drain and gate of power MOSFET. When the transformer is fully demagnetized, the Drain voltage evolution is governed by the resonating energy transfer between the transformer inductor and the global capacitance present on the Drain. These voltage oscillations create current oscillation in the parasitic capacitor Crss. A negative current takes place during the decreasing part of the Drain

oscillation, and a positive current during the increasing part. The transformer demagnetization time corresponds to the inversion of the current by detecting this point, as shown in Fig.1.

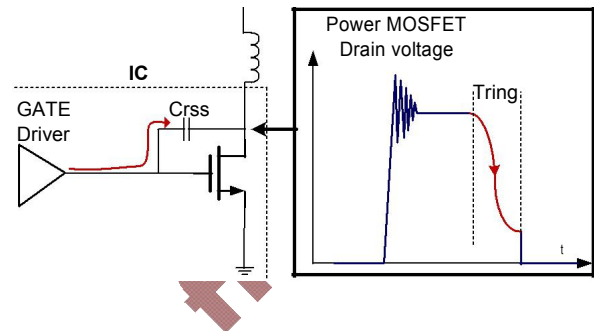

Fig.1

- Quasi Resonant Buck (QR-Buck) Constant Current Control**

In QR-Buck mode, the IC keeps CS peak current constant and starts new PWM cycle with valley switching. Therefore, high precision CC and high conversion efficiency can be achieved simultaneously. The average LED regulation output current is given by:

$$I_{Buck\_CC\_OUT} (mA) \cong \frac{1}{2} \times \frac{500mV}{Rcs \Omega}$$

In the equation above,

Rcs--- the sensing resistor connected between the CS pin to Buck system GND.

- Minimum and Maximum OFF Time**

In DP9127, a minimum OFF time (typically 2.5us) is implemented to suppress ringing when the power MOSFET is off. The minimum OFF time is necessary in applications where the transformer has a large leakage inductance. The maximum OFF time in DP9127 is typically 300us.



- **Current Limit and Leading Edge Blanking**

The current limit circuit samples the differential voltage between VDD and CS, as shown in “Block Diagram”. When the sampled differential voltage exceeds the internal threshold (500mV), the power MOSFET is turned off for the remainder of that cycle. An internal leading edge blanking circuit is built in. During this blanking period (500ns, typical), the cycle-by-cycle current limiting comparator is disabled and cannot switch off the GATE driver.

- **On Chip Thermal Fold-back (OTP)**

DP9127 integrates thermal fold-back function. When the IC temperature is over 150°C, the system output regulation current is gradually reduced, as shown in Fig.2. Thus, the output power and thermal dissipation are also reduced. In this way, the system temperature is limited and system reliability is also improved.

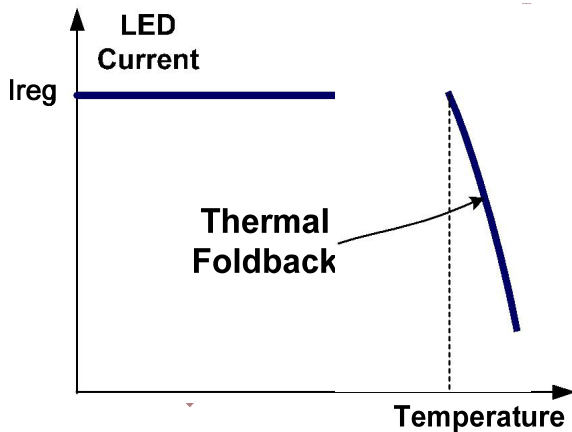

Fig.2

- **Soft Totem-Pole Gate Driver**

DP9127 has a soft totem-pole gate driver with optimized EMI performance.





**Package Dimension**

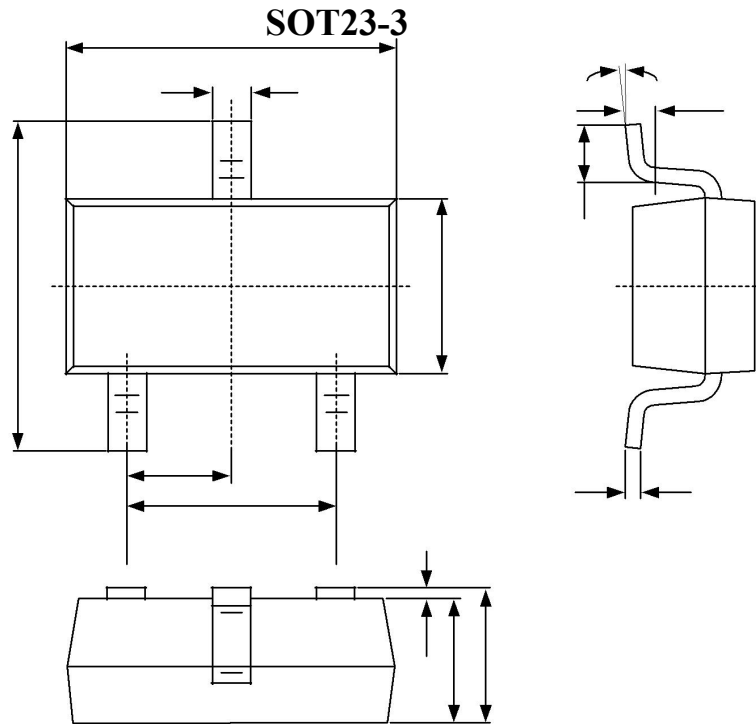

Symbol	Dimensions in Millimeters		Dimensions in Inches	
	Min	Max	Min	Max
A	1.050	1.250	0.041	0.049
A1	0.000	0.100	0.000	0.004
A2	1.050	1.150	0.041	0.045
b	0.300	0.500	0.012	0.020
c	0.100	0.200	0.004	0.008
D	2.820	3.020	0.111	0.119
E	1.500	1.700	0.059	0.067
E1	2.650	2.950	0.104	0.116
e	0.950(BSC)		0.037(BSC)	
e1	1.800	2.000	0.071	0.079
L	0.300	0.600	0.012	0.024
θ	0°	8°	0°	8°



**DP9127**

**Non-isolated Quasi-Resonant Buck LED Power Switch**

**Package Dimension (Continued)**

**TO-92**

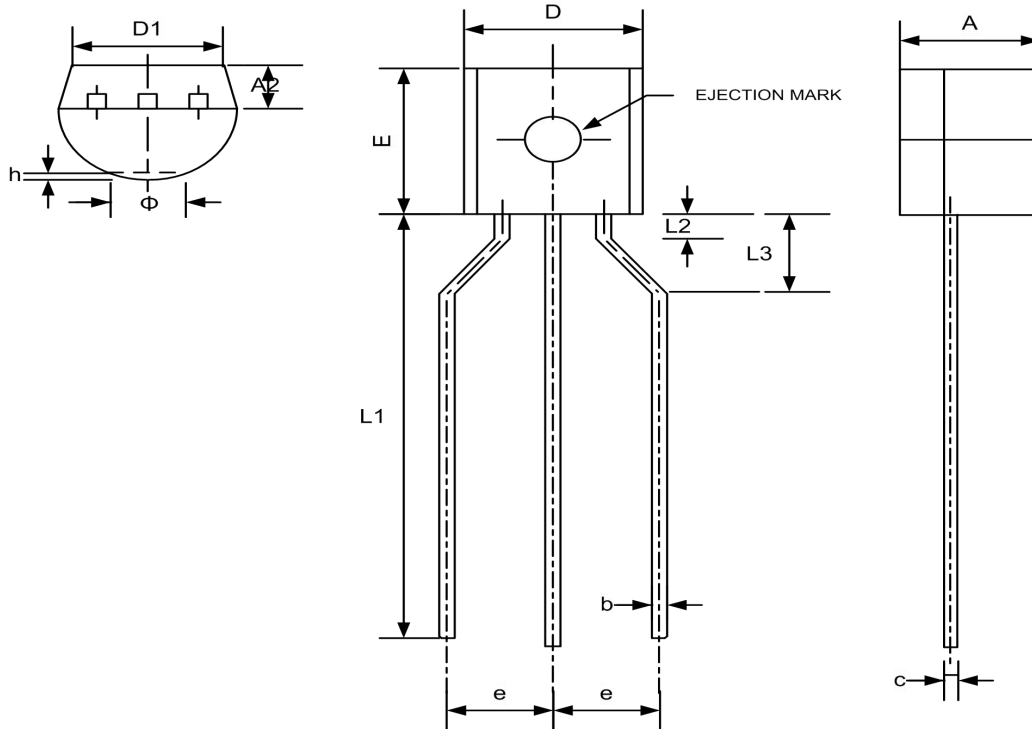

Symbol	Dimensions In Millimeters		Dimensions In Inches	
	Min	Max	Min	Max
A	3.300	3.700	0.130	0.146
A2	1.100	1.400	0.043	0.055
b	0.380	0.550	0.015	0.022
c	0.360	0.510	0.014	0.020
D	4.400	4.700	0.173	0.185
D1	3.430	-	0.135	-
E	4.300	4.700	0.169	0.185
e	2.440	2.640	0.096	0.104
h	0.000	0.380	0.000	0.015
L1	12.500	14.500	0.492	0.571
L3	2.500	3.500	0.098	0.138
$\theta$	-	1.600	-	0.063



**Package Dimension (Continued)**

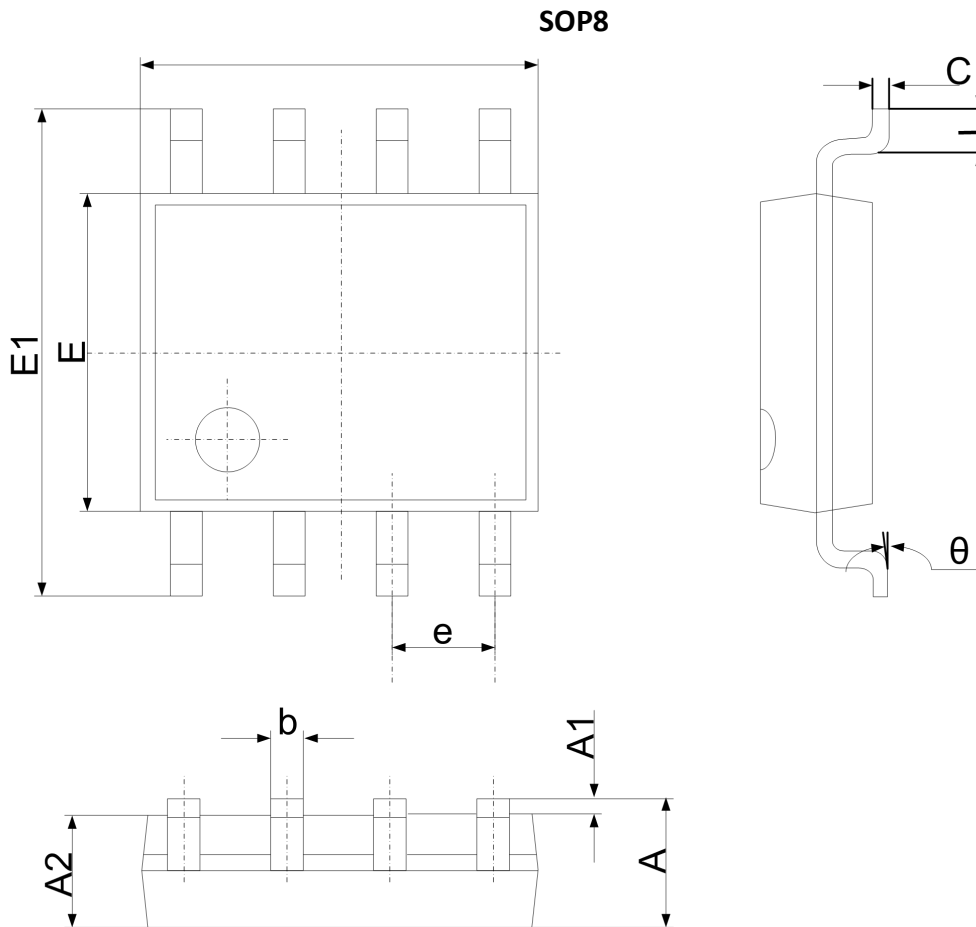

Symbol	Dimensions In Millimeters		Dimensions In Inches	
	Min	Max	Min	Max
A	1.350	1.750	0.053	0.069
A1	0.100	0.250	0.004	0.010
A2	1.350	1.550	0.053	0.061
b	0.330	0.510	0.013	0.020
c	0.170	0.250	0.006	0.010
D	4.700	5.100	0.185	0.200
E	3.800	4.000	0.150	0.157
E1	5.800	6.200	0.228	0.244
e	1.270 (BSC)		0.050 (BSC)	
L	0.400	1.270	0.016	0.050
θ	0°	8°	0°	8°