

## Features

- Compatible with IEEE 802.3/Ethernet (10BASE5), IEEE802.3/Cheapernet (10BASE2) and Ethernet Rev. 1 Specifications
- Compatible with 8003 ELDC<sup>®</sup>, 8005 Advanced EDLC
- Manchester Data Encoding/Decoding and Receiver Clock Recovery with Phase Locked Loop (PLL)
- Receiver and Collision Squelch Circuit and Noise Rejection Filter
- Differential TRANSMIT Cable Driver
- Loopback Capability for Diagnostics and Isolation
- Fail-Safe Watchdog Timer Circuit to Prevent Continuous Transmission
- 20 MHz Crystal Oscillator
- Transceiver Interface High Voltage (16 V) Short Circuit Protection

- Low Power CMOS Technology with Single 5V Supply
- 20 pin DIP & PLCC Packages

## Description

The SEEQ 8020 Manchester Code Converter chip provides the Manchester data encoding and decoding functions of the Ethernet Local Area Network physical layer. It interfaces to the SEEQ 8003 and 8005 Controllers and any standard Ethernet transceiver as defined by IEEE 802.3 and Ethernet Revision 1.

The SEEQ 8020 MCC is a functionally complete Encoder/Decoder including ECL level balanced driver and receivers, on board oscillator, analog phase locked loop for clock

## Pin Configuration

### DUAL-IN LINE TOP VIEW

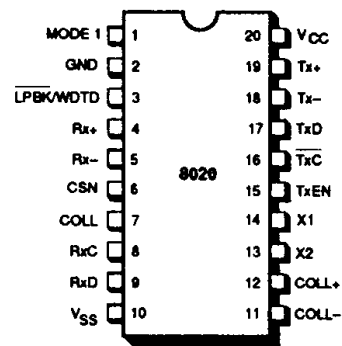

### PLASTIC LEADED CHIP CARRIER TOP VIEW

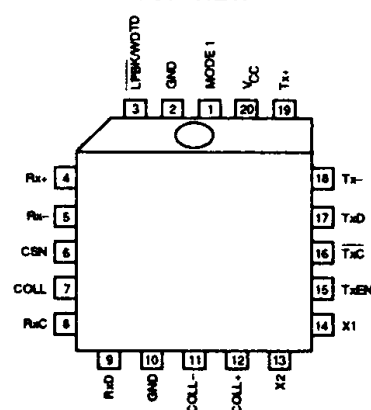

## Functional Block Diagram

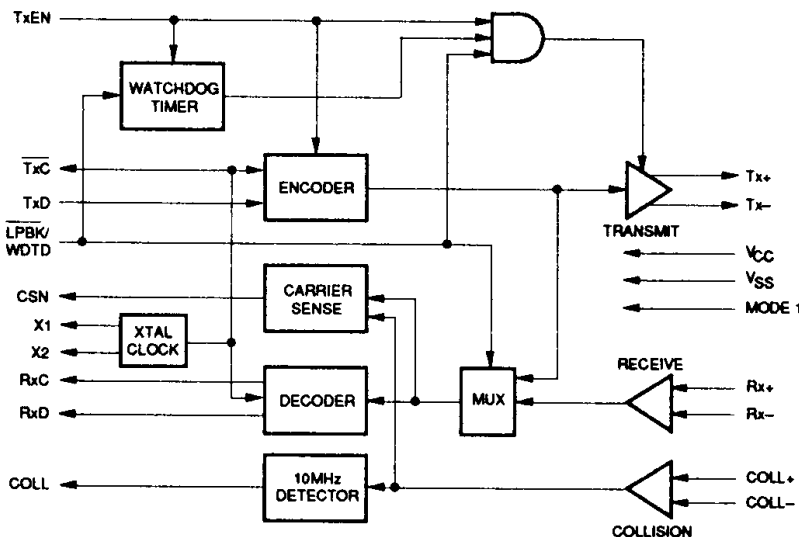

Figure 1. 8020 MCC Manchester Code Converter Block Diagram.

MCC is a trademark of SEEQ Technology Inc.  
EDLC is a registered trademark of SEEQ Technology Inc.

recovery and collision detection circuitry. In addition, the 8020 includes a watchdog timer, a 4.5 microsecond window generator, and a loopback mode for diagnostic operation.

Together with the 8003 or 8005 and a transceiver, the 8020 Manchester Code Converter provides a high performance minimum cost interface for any system to Ethernet.

## Functional Description

The 8020 Manchester Code Converter chip has two portions, transmitter and receiver. The transmitter uses Manchester encoding to combine the clock and data into a serial stream. It also differentially drives up to 50 meters of twisted pair transmission line. The receiver detects the presence of data and collisions. The 8020 MCC recovers the Manchester encoded data stream and decodes it into clock and data outputs. Manchester Encoding is the process of combining the clock and data stream so that they may be transmitted on a single twisted pair of wires, and the clock and data may be recovered accurately upon reception. Manchester encoding has the unique property of a transition at the center of each bit cell, a positive going transition for a "1", and a negative going transition for a "0" (See Figure 2). The encoding is accomplished by exclusive-ORing the clock and data prior to transmission, and the decoding by deriving the clock from the data with a phase locked loop.

### Clock Generator

The internal oscillator is controlled by a 20 MHz parallel resonant crystal or by an external clock on X1. The 20 MHz clock is then divided by 2 to generate a 10 MHz  $\pm 0.01\%$  transmitter clock. Both 10 MHz and 20 MHz clocks are used in Manchester data encoding.

### Manchester Encoder and Differential Output Driver

The encoder combines clock and data information for the transceiver. In Manchester encoding, the first half of the bit

cell contains the complement of the data and the second half contains the true data. Thus a transition is always guaranteed in the middle of a bit cell.

Data encoding and transmission begin with TxEN going active; the first transition is always positive for Tx(-) and negative for Tx(+). In IEEE mode, at the termination of a transmission, TxEN goes inactive and transmit pair approach to zero differential. In Ethernet mode, at the end of the transmission, TxEN goes inactive and the transmit pair stay differentially high. The transmit termination can occur at bit cell center if the last bit is a one or at a bit boundary if the last bit is a zero. To eliminate DC current in the transformer during idle, Tx $\pm$  is brought to 100 mV differential in 600 ns after the last transition (IEEE mode). The back swing voltage is guaranteed to be less than .1 V.

### Watchdog Timer

A watchdog timer is built on chip. It can be enabled or disabled by the LPBK/WDTD signal. The timer starts counting at the beginning of the transmission. If TxEN goes inactive before the timer expires, the timer is reset and ready for the next transmission. If the timer expires before the transmission ends, transmission is aborted by disabling the differential transmitter. This is done by idling the differential output drivers (differential output voltage becomes zero) and deasserting CSN.

### Differential Input Circuit (Rx+ and Rx-, COLL+ and COLL-).

As shown in Figure 3, the differential input for Rx+ and Rx- and COLL+ and COLL- are externally terminated by a pair of 39.2  $\Omega \pm 1\%$  resistors in series for proper impedance matching.

The center tap has a 0.01  $\mu\text{F}$  capacitor, tied to ground, to provide the AC common mode impedance termination for the transceiver cable.

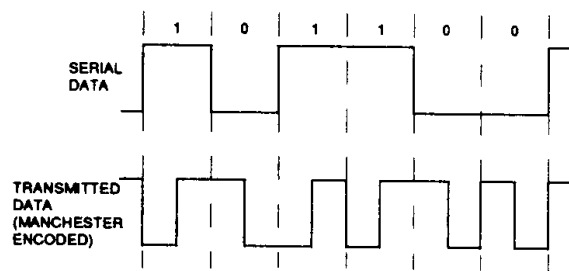

Figure 2. Manchester Coding

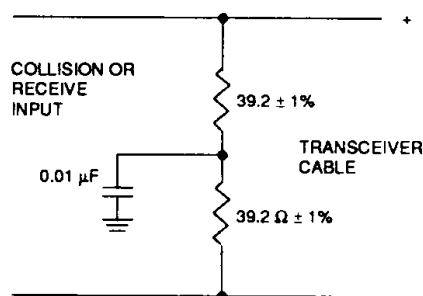

Figure 3. Differential Input Terminator

Both collision and receiver input circuits provide a static noise margin of -140 mV to -300mV (peak value). Noise rejection filters are provided at both input pairs to prevent spurious signals. For the receiver pair, the range is 15 ns to 30 ns. For the collision pair, the range is 10 ns to 18 ns. The D.C. threshold and noise rejection filter assure that differential receiver data signals less than -140 mV in amplitude or narrower than 15 ns (10 ns for collision pair) are always rejected, signals greater than -300 mV and wider than 30 ns (18 ns for collision pair) are always accepted.

#### Manchester Decoder and Clock Recovery Circuit

The filtered data is processed by the data and clock recovery circuit using a phase-locked loop technique. The PLL is designed to lock onto the preamble of the incoming signal with a transition width asymmetry not greater than +8.25 ns to -8.25 ns within 12 bit cell times worst case and can sample the incoming data with a transition width asymmetry of up to +8.25 ns to -8.25 ns. The RxC high or low time will always be greater than 40 ns. RxC follows  $\overline{\text{TxC}}$  for the first 1.2  $\mu\text{s}$  and then switches to the recovered clock. In addition, the Encoder/Decoder asserts the CSN signal while it is receiving data from the cable to indicate the receiver data and clock are valid and available. At the end of the frame, after the node has finished transmitting, CSN is deasserted and will not be asserted again for a period of 4.5  $\mu\text{s}$  regardless of the state of the state of the receiver pair or collision pair. This is called inhibit period. There is no inhibit period after packet reception. During clock switching, RxC may stay high for 200ns maximum.

#### Collision Circuit

A collision on the Ethernet cable is sensed by the transceiver. It generates a 10 MHz  $\pm 15\%$  differential square wave to indicate the presence of the collision. During the collision period, CSN is asserted asynchronously with RxC. However, if a collision arrives during inhibit period 4.5  $\mu\text{s}$  from the time CSN was deasserted, CSN will not be reasserted.

#### Loopback

In loopback mode, encoded data is switched to the PLL instead of Tx+/Tx- signals. The recovered data and clock are returned to the Ethernet Controller. All the transmit and receive circuits, including noise rejection filter, are tested except the differential output driver and the differential input receiver circuits which are disabled during loopback. At the end of frame transmission, the 8020 also generates a 650 ns long COLL signal 550 ns after CSN was deasserted to simulate the IEEE 802.3 SQE test. The watchdog timer remains enabled in this mode.

## Pin Description

The MCC chip signals are grouped into four categories:

- Power Supply and Clock
- Controller Interface
- Transceiver Interface
- Miscellaneous

### Power Supply

$V_{CC}$  .....+5V  
 $V_{SS}$  .....Ground

**X1 and X2 clock (Inputs):** Clock Crystal: 20 MHz crystal oscillator input. Alternately, pin X1 may be used at a TTL level input for external timing by floating pint X2,

### Controller Interface

**RxC Receive Clock (Output):** This signal is the recovered clock from the phase decoder circuit. It is switched to  $\overline{\text{TxC}}$  when no incoming data is present from which a true receive clock is derived. 10 MHz nominal and TTL compatible.

**RxD Receive Data (Output):** The RxD signal is the recovered data from the phase decoder. During idle periods, the RxD pin is LOW under normal conditions. TTL and MOS level compatible. Active HIGH.

**CSN Carrier Sense (Output):** The Carrier Sense Signal indicates to the controller that there is activity on the coaxial cable. It is asserted when receive data is present or when a collision signal is present. It is deasserted at the end of frame or at the end of collision, whichever occurs later. It is asserted or deasserted synchronously with RxC. TTL compatible.

**$\overline{\text{TxC}}$  Transmit Clock (Output):** A 10 MHz signal derived from the internal oscillator. This clock is always active. TTL and MOS level compatible.

**TxD Transmit Data (Input):** TxD is the NRZ serial input data to be transmitted. The data is clocked into the MCC by  $\overline{\text{TxC}}$ . Active HIGH, TTL compatible.

**TxEN Transmit Enable (Input):** Transmit Enable, when asserted, enables data to be sent to the cable. It is asserted synchronously with  $\overline{\text{TxC}}$ . TxEN goes active with the first bit of transmission. TTL compatible.

**COLL Collision (Output):** When asserted, indicates to the controller the simultaneous transmission of two or more stations on network cable. TTL Compatible.

### Transceiver Interface

**Rx+ and Rx- Differential Receiver Input Pair (Input):** Differential receiver input pair which brings the encoded receive data to the 8020. The last transition is always positive-going to indicate the end of the frame.

**COLL+ and COLL- Differential Collision Input Pair (Input):** This is a 10 MHz  $\pm$  15% differential signal from the transceiver indicating collision. The duty cycle should not be worse than 60%/40% — 40%/60%. The last transition is positive-going. This signal will respond to signals in the range of 5 MHz to 11.5 MHz. Collision signal may be asserted if 'MAU not available' signal is present.

**Tx+ and Tx- Differential Transmit Output Pair (Output):** Differential transmit pair which sends the encoded data to the transceiver. The cable driver buffers are source follower and require external 243  $\Omega$  resistors to ground as

loading. These resistors must be rated at 1 watt to withstand the fault conditions specified by IEEE 802.3. If MODE 1=1, after 200 ns following the last transition, the differential voltage is slowly reduced to zero volts in 8  $\mu$ s to limit the back swing of the coupling transformer to less than 0.1 V.

### Miscellaneous

**MODE 1 (Input):** This pin is used to select between AC or DC coupling. When it is tied high or left floating, the output drivers provide differential zero signal during idle (IEEE 802.3 specification). When pin 1 is tied low, then the output is differentially high when idle (Ethernet Rev.1 specification).

### LPBK/WDTD Loopback /Watchdog Timer Disable (Input):

**Normal Operation:** For normal operation this pin should be HIGH or tied to  $V_{CC}$ . In normal operation the watchdog timer is enabled.

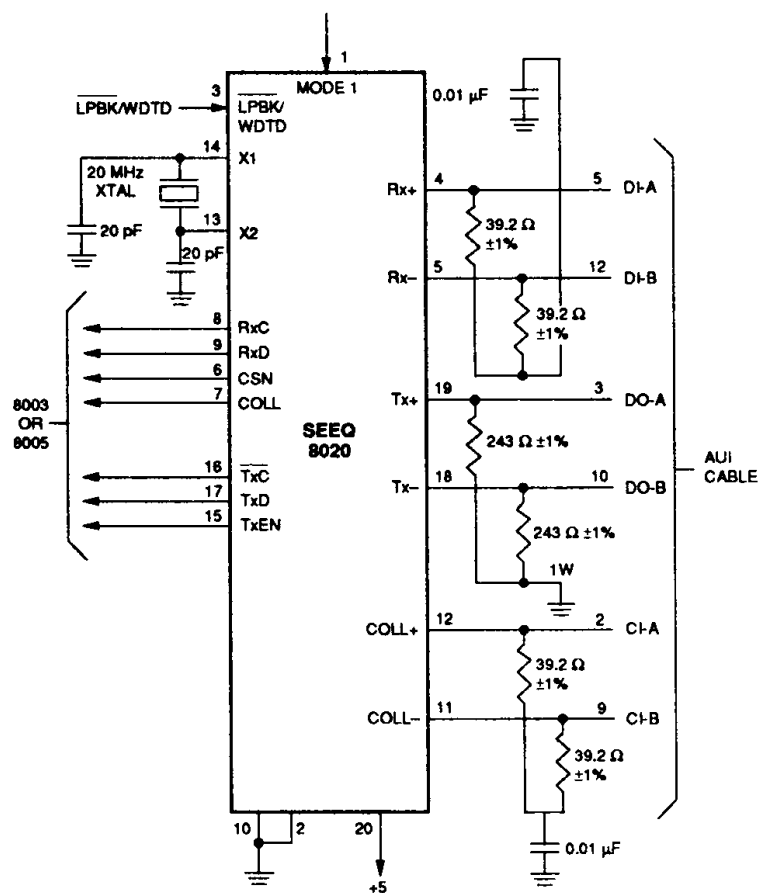

Figure 4. 8020 Interface

**SEEQ**  
Technology, Incorporated

MD400023/C

**Loopback:** When this pin is brought low, the Manchester encoded transmit data from TxD and TxC is routed through the receiver circuit and sent back onto the RxD and RxC Pins. During loopback, Collision and Receive data inputs are ignored. The transmit pair is idled. At the end of transmission, the signal quality error test (SQET) will be simulated by asserting collision during the inhibit window. During loopback, the watchdog timer is enabled.

**Watchdog Timer Disable:** When this pin is between 10 V (Min.) and 16 V (Max.), the on chip 25 ms Watchdog Timer will be disabled. The watchdog timer is used to monitor the transmit enable pin. If TxEN is asserted for too long, then the watchdog timer (if enabled) will automatically deassert CSN and inhibit any further transmissions on the Tx+ and Tx- lines. The watchdog timer is automatically reset each time TxEN is deasserted.

**Interconnection to a Data Link Controller**

Figure 5 shows the interconnections between the 8020 MCC and SEEQ's 8003 or 8005. There are three connections for each of the two transmission channels, transmit and receive, plus the Collision Signal line (COLL).

Transmitter connections are:

- Transmit Data, TxD
- Transmit Clock, TxC
- Transmit Enable, TxEN
- Collision, COLL

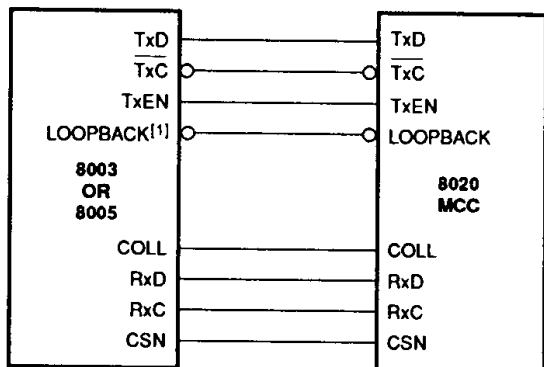

Figure 5. Interconnection of 8020 and 8003/8005

**NOTE**

1. Loopback output on 8005 only.

Receiver connections are:

- Receive Data, RxD
- Receive Clock, RxC
- Carrier Sense, CSN

**D.C. and A.C. Characteristics and Timing**

**Crystal Specification**

Resonant Frequency ( $C_L = 20 \text{ pF}$ )	20 MHz
	$\pm 0.005\%$ 0-70° C
	and $\pm 0.003\%$ at 25° C
Type	Fundamental Mode
Circuit	Parallel Resonance
Load Capacitance ( $C_L$ )	20pF
Shunt Capacitance ( $C_0$ )	7pF Max.
Equivalent Series Resistance (R1)	25Ω Max.
Motional Capacitance (C1)	0.02 pF Max.
Drive Level	2mW

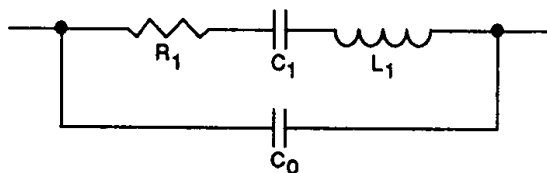

EQUIVALENT CIRCUIT OF CRYSTAL

Figure 6.

**Absolute Maximum Rating\***

Storage Temperature ..... -65°C to +150°C  
 All Input or Output Voltage ..... -0.3 to  $V_{CC} + 0.3$   
 $V_{CC}$  ..... -0.3 to 7V  
 ( $Rx\pm$ ,  $Tx\pm$ ,  $COLL\pm$ ) High Voltage  
 Short Circuit Immunity ..... -0.3 to 16V

\*COMMENT: Stresses above those listed under "Absolute Maximum Ratings" may cause permanent damage to the device. This is a stress rating only and functional operation of the device at these or any other conditions above those indicated in the operational sections of this specification is not implied. Exposure to absolute maximum rating conditions for extended periods may affect device reliability.

**DC Characteristics**  $T_A = 0^\circ\text{C}$  to  $70^\circ\text{C}$ ;  $V_{CC} = 5\text{ V} \pm 5\%$ 

Symbol	Parameter	Min.	Max.	Unit	Conditions
$I_{IL}$	Input Leakage Current (except MODE 1, Receive and Collision Pairs)		10	$\mu\text{A}$	$0 \leq V_{IN} \leq V_{CC}$
	MODE 1 Input Leakage Current		200	$\mu\text{A}$	$0 \leq V_{IN} \leq V_{CC}$
	Receive and Collision Pairs ( $Rx\pm$ , $COLL\pm$ ) Input Leakage Current		2	$\text{mA}$	$V_{IN} = 0$
$I_{CC}$	$V_{CC}$ Current		75	$\text{mA}$	All Inputs, Outputs Open
$V_{IL}$	TTL Input Low Voltage	-0.3	0.8	V	
$V_{IH}$	TTL Input High Voltage (except X1)	2.0	$V_{CC} + 0.3$	V	
	X1 Input High Voltage	3.5	$V_{CC} + 0.3$	V	
$V_{OL}$	TTL Output Low Voltage except $TxC$		0.4	V	$I_{OL} = 2.1\text{ mA}$
	$\overline{TxC}$ Output Low Voltage		0.4	V	$I_{OL} = 4.2\text{ mA}$
$V_{OH}$	TTL Output High Voltage (except $RxC$ , $\overline{TxC}$ , $RxD$ )	2.4		V	$t_{OH} = -400\ \mu\text{A}$
	$RxC$ , $\overline{TxC}$ , $RxD$ Output High Voltage	3.9		V	$t_{OH} = -400\ \mu\text{A}$
$V_{ODF}$	Differential Output Swing	$\pm 0.55$	$\pm 1.2$	V	78 $\Omega$ Termination Resistor and 243 $\Omega$ Load Resistors
$V_{OCM}$	Common Mode Output Voltage	$V_{CC} - 2.5$	$V_{CC} - 1$	V	78 $\Omega$ Termination Resistor and 243 $\Omega$ Load Resistors
$V_{BKSV}$	$Tx\pm$ Backswing Voltage During Idle		0.1	V	Shunt Inductive Load $\leq 27\ \mu\text{H}$
$V_{IDF}$	Input Differential Voltage (measured differentially)	$\pm 0.3$	$\pm 1.2$	V	
$V_{ICM}$	Input Common Mode Voltage	0	$V_{CC}$	V	
$C_{IN}^{[1]}$	Input Capacitance		15	$\text{pF}$	
$C_{OUT}^{[1]}$	Output Capacitance		15	$\text{pF}$	

**NOTE:**

1. Characterized. Not tested

**SEEQ**

Technology, Incorporated

MD400023/C

**AC Test Conditions**

Output Loading TTL Output:

50% point of swing

Differential Output:

20% to 80% points

Differential Signal Delay Time Reference Level:

Differential Output Rise and Fall Time:

High time measured at 3.0V

Rx $\overline{C}$ , Tx $\overline{C}$ , X1 High and Low Time:

Low time measured at 0.6V

Rx $\overline{D}$ , Rx $\overline{C}$ , Tx $\overline{C}$ , X1 Rise and Fall Time:

Measured between 0.6V and 3.0V points

TTL Input Voltage (except X1):

0.8V to 2.0V with 10 ns rise and fall time

X1 Input Voltage:

0.8V to 3.5V with 5 ns rise and fall time

Differential Input Voltage:

At least  $\pm 300$  mV with rise and fall time of 10 ns measured between  $-0.2$ V and  $+0.2$ V

1 TTL gate and 20 pF capacitor.

243 $\Omega$  resistor and 10 pF capacitor from each pin to  $V_{SS}$   
and a termination 78 $\Omega$  resistor load resistor in parallel with  
a 27  $\mu$ H inductor between the two differential output pins

**20 MHz TTL Clock Input Timing**  $T_A = 0^\circ\text{C}$  to  $70^\circ\text{C}$ ;  $V_{CC} = 5\text{V} \pm 5\%$ 

Symbol	Parameter	Min.	Max.	Unit
$t_1$	X1 Cycle Time	49.995	50.005	ns
$t_2$	X1 High Time	15		ns
$t_3$	X1 Low Time	15		ns
$t_4$	X1 Rise Time		5	ns
$t_5$	X1 Fall Time		5	ns
$t_{5A}$	X1 to Tx $\overline{C}$ Delay Time	10	45	ns

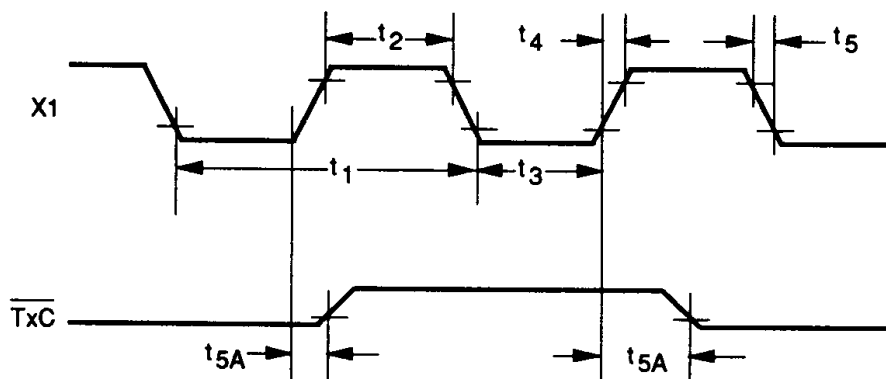

Figure 12. 20 MHz TTL Clock Timing

**SEEQ**

Technology, Incorporated

MD400023/C

**Transmit Timing**  $T_A = 0^\circ\text{C to } 70^\circ\text{C}; V_{CC} = 5\text{V} \pm 5\%$ 

Symbol	Parameter	Min.	Max.	Unit
$t_6^{(1)}$	$\overline{\text{Tx}}\overline{\text{C}}$ Cycle Time	99.99	100.01	ns
$t_7$	$\overline{\text{Tx}}\overline{\text{C}}$ High Time	40		ns
$t_8$	$\overline{\text{Tx}}\overline{\text{C}}$ Low Time	40		ns
$t_9^{(1)}$	$\overline{\text{Tx}}\overline{\text{C}}$ Rise Time		5	ns
$t_{10}^{(1)}$	$\overline{\text{Tx}}\overline{\text{C}}$ Fall Time		5	ns
$t_{11}$	TxEN Setup Time	40		ns
$t_{12}$	TxD Setup Time	40		ns
$t_{13}^{(1)}$	Bit Center to Bit Center Time	99.5	100.5	ns
$t_{14}^{(1)}$	Bit Center to Bit Boundary Time	49.5	50.5	ns
$t_{15}^{(1)}$	Tx+ and Tx – Rise Time		5	ns
$t_{16}^{(1)}$	Tx+ and Tx – Fall Time		5	ns
$t_{17}$	Transmit Active Time From The Last Positive Transition	200		ns
$t_{17A}^{(1)}$	From Last Positive Transition of the Transmit Pair to Differential Output Approaches within 100 mV of 0 V	400	600	ns
$t_{17B}^{(1)}$	From Last Positive Transition of the Transmit Pair to Differential Output Approaches within 40 mV of 0 V		7000	ns
$t_{18}$	Tx+ and Tx– Output Delay Time		70	ns
$t_{19}$	TxD Hold Time	15		ns
$t_{20}$	TxEN Hold Time	15		ns

**NOTE:**

1. Characterized. Not tested.



MODE 1=1

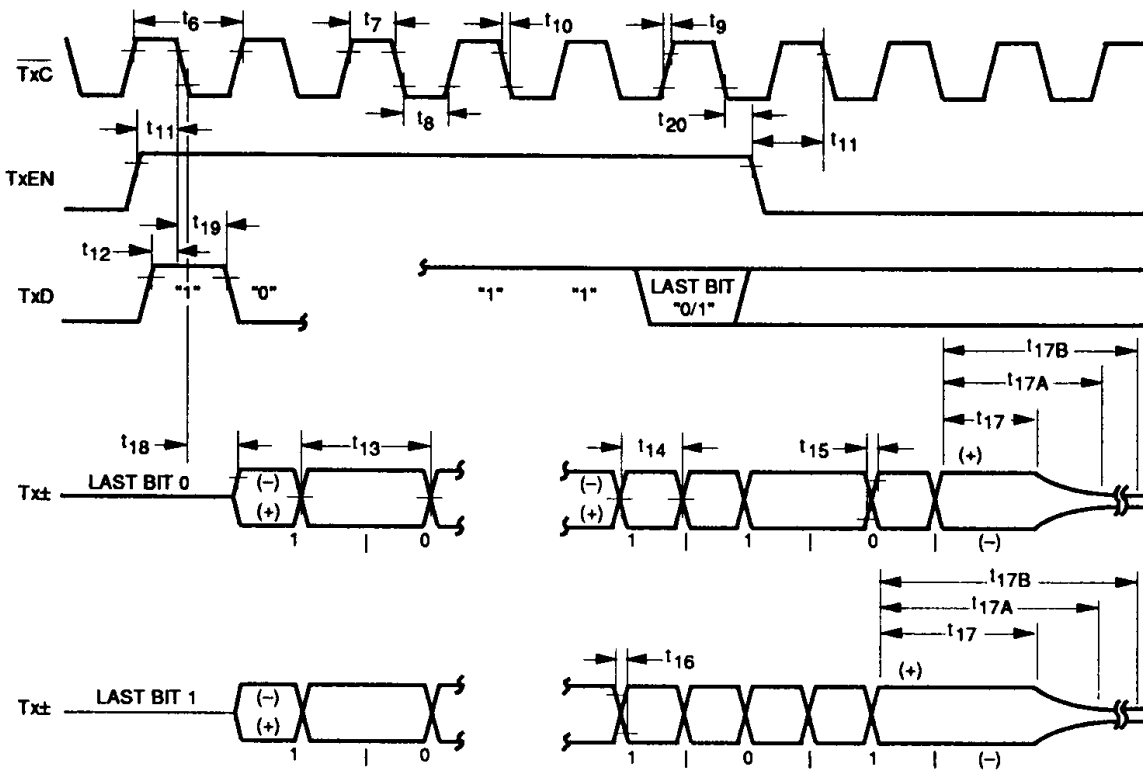

Figure 7. Transmit Timing

MODE 1=0

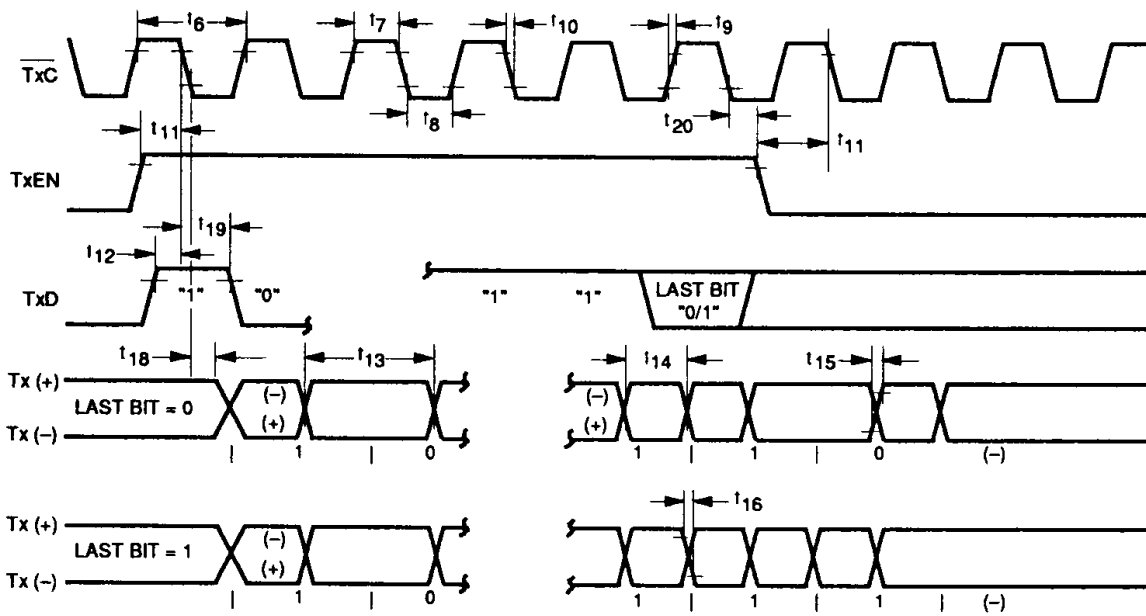

Figure 8. Transmit Timing

**Receive Timing**  $T_A = 0^\circ\text{C to } 70^\circ\text{C}; V_{CC} = 5\text{ V} \pm 5\%$ 

Symbol	Parameter	Min.	Max.	Unit
$t_{21}$	CSN Assert Delay Time		240	ns
$t_{22}$	CSN Deasserts Delay Time (measured from Last Bit Boundary)		240	ns
$t_{23A}$	CSN Hold Time	30		ns
$t_{23B}$	CSN Set up Time	30		ns
$t_{24}$	RxD Hold Time	30		ns
$t_{25}$	RxD Set up Time	30		ns
$t_{26}^{(1)}$	RxC Rise and Fall Time		5	ns
$t_{27}^{(1)}$	During Clock Switch RxC Keeps High Time	40	200	ns
$t_{28}$	RxC High and Low Time	40		ns
$t_{29}^{(1)}$	RxC Clock Cycle Time (during data period)	95	105	ns
$t_{30}$	CSN Inhibit Time (on Transmission Node only)	4.3	4.6	$\mu\text{s}$
$t_{31}$	Rx+/Rx- Rise and Fall Time		10	ns
$t_{32}^{(1)}$	Rx+/Rx- Begin Return to Zero from Last Positive-Going Transition	160		ns
$t_{33}^{(1)}$	RxD Rise Time		10	ns
$t_{34}^{(1)}$	RxD Fall Time		10	ns

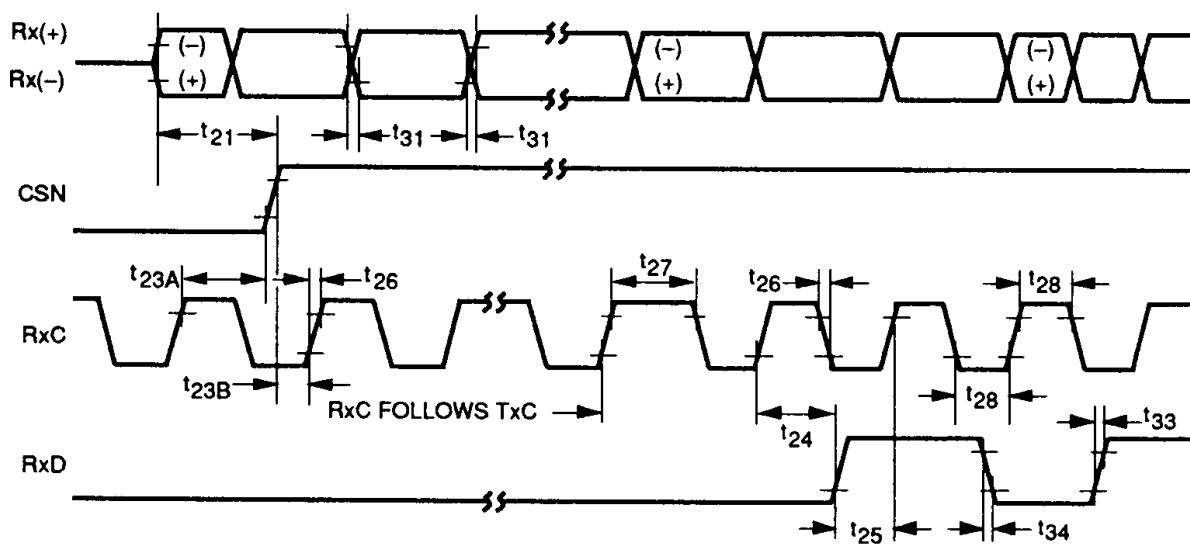

Figure 9. Receive Timing-Start of Packet

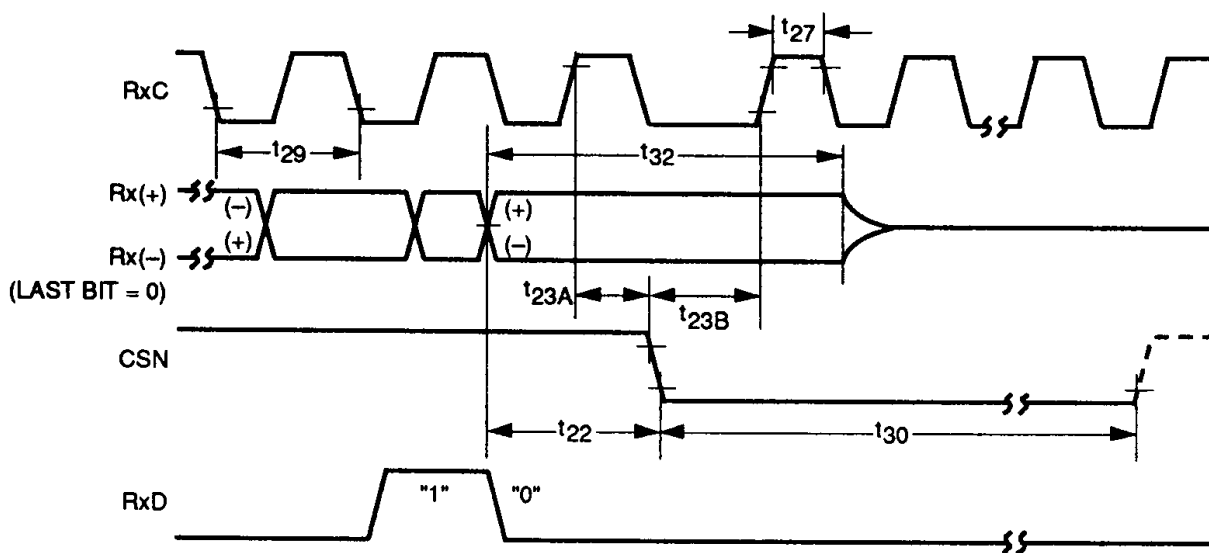

Figure 10. Receive Timing-End of Packet

MANCHESTER  
CODE  
CONVERTERS

**Collision Timing**  $T_A = 0^\circ\text{C}$  to  $70^\circ\text{C}$ ;  $V_{CC} = 5\text{V} \pm 5\%$ 

Symbol	Parameter	Min.	Max.	Unit
$t_{51}$	COLL+ /COLL — Cycle Time	86	118	ns
$t_{52}$	COLL+/COLL — Rise and Fall Time		10	ns
$t_{53}$	COLL+/COLL — High and Low Time	35	70	ns
$t_{54}$	COLL+/COLL — Width (measured at $-0.3\text{V}$ )	26		ns
$t_{55}$	COLL Asserts Delay Time		300	ns
$t_{56}$	COLL Deasserts Delay Time		500	ns
$t_{57}$	CSN Asserts Delay Time		400	ns
$t_{58}$	CSN Deasserts Delay Time		600	ns

**NOTES:**

1. COLL + and COLL - asserts and deasserts COLL, asynchronously, and asserts and deasserts CSN synchronously with RxC.
2. If COLL + and COLL - arrives within  $4.5\mu\text{s}$  from the time CSN was deasserted; CSN will not be reasserted (on transmission node only).
3. When COLL + and COLL - terminates, CSN will not be deasserted if Rx+ and Rx- are still active.
4. When the node finishes transmitting and CSN deasserted, it cannot be asserted again for  $4.5\mu\text{s}$ .

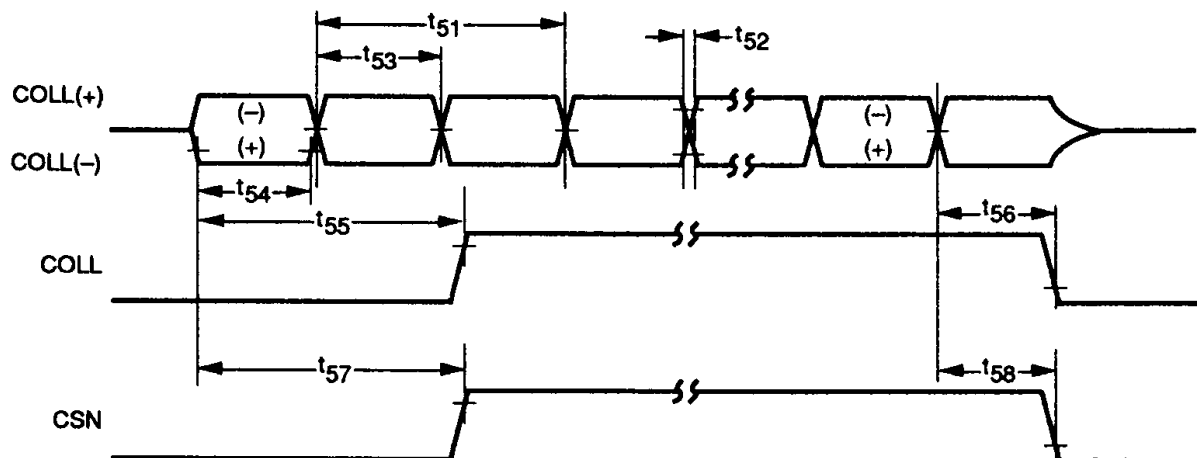

Figure 11. Collision Timing

**Loopback Timing**  $T_A = 0^\circ\text{C}$  to  $70^\circ\text{C}$ ;  $V_{CC} = 5\text{ V} \pm 5\%$

Symbol	Parameter	Min.	Max.	Unit
$t_{61}$	LPBK Setup Time	500		ns
$t_{62}$	LPBK Hold Time	5		$\mu\text{s}$
$t_{63}$	In Collision Simulation, COLL Signal Delay Time	475	625	ns
$t_{64}$	COLL Duration Time	600	750	ns

**NOTES:**

1. PLL needs 12-bit cell times to acquire lock, RxD is invalid during this period.

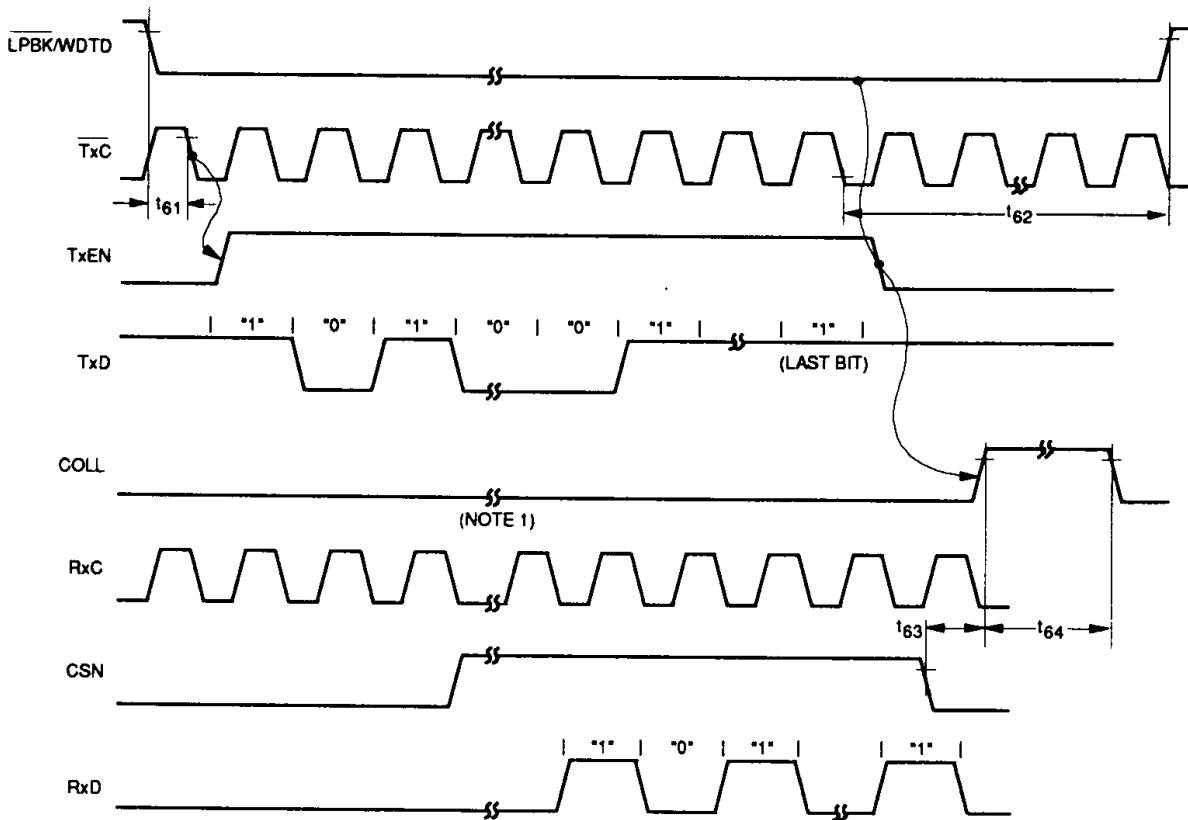
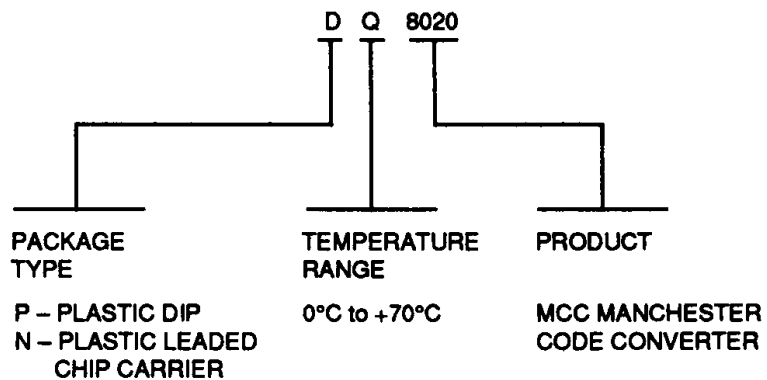

Figure 13. Loopback Timing

MANCHESTER  
CODE  
CONVERTERS

**Ordering Information****SEEQ**

Technology, Incorporated

MD400023/C