

DR4200
Circular Chart Recorder
EV Model
Product Manual

44-01-25-09D
6/98

Copyright, Notices, and Trademarks

Printed in U.S.A. – © Copyright 1998 by Honeywell Inc.

Revision D – 6/98

While this information is presented in good faith and believed to be accurate, Honeywell disclaims the implied warranties of merchantability and fitness for a particular purpose and makes no express warranties except as may be stated in its written agreement with and for its customer.

In no event is Honeywell liable to anyone for any indirect, special or consequential damages. The information and specifications in this document are subject to change without notice.

This document was prepared using Information Mapping® methodologies and formatting principles.

DR4200 is a trademark of Honeywell Inc.

Information Mapping is a trademark of Information Mapping Inc.

Honeywell
Industrial Automation and Control
Automation College
2820 West Kelton Lane
Phoenix, AZ 85023

About This Publication

How this manual is organized

This Product Manual is divided into 11 sections. These sections contain all the information you need to set up, configure, operate, monitor, and troubleshoot your recorder.

To find information quickly, use the comprehensive Table of Contents in the front of the manual and the Index located in the back of the manual.

Warranty

The device described herein has been manufactured and tested for correct operation and is warranted as follows:

The DR4200 Model EV Circular Chart Recorder carries a two year warranty.

Technical Assistance

If you encounter a problem with your DR4200 recorder, review all the Set Up, Installation, and Configuration data to verify that your selections are consistent with your application. If the problem persists after checking the above, you can get technical assistance by dialing

1-800-423-9883 in USA and Canada

An engineer will discuss your problem with you. Please have your complete model number, serial number, and software version available. The model and serial numbers can be found on the chart plate.

If it is determined that a hardware problem exists, a replacement recorder or part will be shipped with instructions for returning the defective unit. Do not return your recorder without authorization from Honeywell's Technical Assistance Center or until the replacement has been received.

Symbol Definitions



This **CAUTION** symbol on the equipment refers the user to the Product Manual for additional information. This symbol appears next to required information in the manual.



WARNING—risk of electric shock. This symbol warns the user of a potential shock hazard where HAZARDOUS LIVE voltages greater than 30 Vrms, 42.4 Vpeak, or 60 Vdc may be accessible.



Protective earth terminal. Provided for connection of the protective earth (green or green/yellow) supply system conductor.



Functional earth terminal. Used for non-safety purposes such as noise immunity improvement.

Table of Contents

SECTION 1 – OVERVIEW.....	1
1.1 Introduction	1
1.2 Model Number and Hardware Description	3
1.3 Operator Interface	6
1.4 Pre-Setup Operational Check	8
SECTION 2 – RECORDER SET UP TASKS	9
2.1 Introduction	9
2.2 Configuration Selections for Recording.....	10
2.3 Optional Control Output Setup	15
SECTION 3 – INSTALLATION.....	23
3.1 Overview	23
3.2 Mounting Considerations and Overall Dimensions	27
3.3 Mounting Methods.....	28
3.4 Wiring Prerequisites	32
3.5 Input Wiring Procedures.....	35
3.6 Output Wiring Procedures.....	41
SECTION 4 – CONFIGURATION	45
4.1 Overview	45
4.2 Configuration Prompts	46
4.3 How To Get Started	47
4.4 Configuration Tips.....	48
4.5 Configuration Procedure	49
4.6 Chart Parameters Set Up Group.....	51
4.7 Pen Parameters Set Up Group	52
4.8 Input Parameters Set Up Group.....	53
4.9 Total Parameters Set Up Group.....	57
4.10 Output Set Up Group	59
4.11 Control Parameters Set Up Group.....	60
4.12 Tuning Parameters Set Up Group.....	64
4.13 Cycle Parameters Set Up Group.....	66
4.14 Alarms Set Up Group.....	67
4.15 Lock Parameters Set Up Group	70
4.16 Configuration Record Sheet.....	71
SECTION 5 – OPERATION AND MAINTENANCE	73
5.1 Overview	73
5.2 Preparing the Recorder for Operation.....	74
5.3 Running the Optional Self-Test	75
5.4 Start-up	77
5.5 Monitoring Your Recorder	82
5.6 Operator Functions	86
5.7 Operating Modes.....	87
5.8 Changing the Control Setpoint	89
5.9 Alarm Setpoints.....	90
5.10 Resetting the Totalizer Value	91
5.11 Changing Input Type and Restoring Factory or Field Calibration Values ..	92
5.12 Maximizing Pen Life	94
5.13 Routine Maintenance	95

Table of Contents

SECTION 6 – CALIBRATION.....	97
6.1 Overview.....	97
6.2 Input Calibration Minimum and Maximum Range Values.....	98
6.3 Input Calibration Preliminary Information.....	99
6.4 Input Calibration Set Up and Wiring	101
6.5 Input Calibration Procedure.....	105
6.6 Current Proportional Output Calibration	108
SECTION 7 – TROUBLESHOOTING / SERVICE	111
7.1 Overview.....	111
7.2 Troubleshooting Aids.....	113
7.3 Self Diagnostics.....	115
7.4 Visual Failure Symptoms	119
7.5 Troubleshooting Procedures.....	120
7.6 Replacement Procedures	126
7.7 Checking Mechanical Pen Alignment at Zero.....	132
7.8 Checking the Electrical Pen Alignment at Span and Zero.....	133
SECTION 8 – PARTS LIST.....	137
8.1 Overview.....	137
8.2 Exploded Views	138
APPENDIX A – MANUAL TUNING	143
A.1 Overview.....	143
A.2 Time or Current Proportional Simplex Control.....	144
A.3 Time Proportional Duplex Control.....	147
APPENDIX B – HOW TO APPLY DIGITAL INSTRUMENTATION IN SEVERE ELECTRICAL NOISE ENVIRONMENTS.....	149
B.1 Overview.....	149
B.2 Potential Noise Sources	150
B.3 Prevention Methods.....	151
B.4 Recommended Wiring Practices	152
B.5 Power Source Considerations	154
B.6 Noise Suppression at the Source	155
APPENDIX C - ACCURACY.....	159
C.1 Overview.....	159
APPENDIX D – AVAILABLE 10-INCH CHARTS.....	161
D.1 Single Range Charts	161
D.2 Dual Range Charts.....	167

Figures

Figure 1-1	Model Number Interpretation	3
Figure 1-2	Hardware Components for Model DR4200EV1	4
Figure 1-3	Hardware Components for Model DR4200EV2	5
Figure 1-4	Operator Interface	6
Figure 2-1	DIP Switch and Jumper Locations	10
Figure 2-2	Jumper W1 Positions (AC Line Power)	11
Figure 2-3	Jumpers W3/W4 Positions (Burnout)	12
Figure 2-4	DIP Switch and Jumper Locations for Actuation Selections	14
Figure 2-5	Mounting the Control Output Printed Circuit Board on the Main Printed Circuit Board	16
Figure 2-6	Jumper Locations on Optional Control Printed Circuit Board	18
Figure 2-7	Jumper Positions for Relay and Current Output on Control PCB 30756087-001	20
Figure 2-8	Jumper Locations for Relay #1 Action	21
Figure 2-9	Jumper Locations for Relay #2 Action	22
Figure 3-1	Overall Dimensions	27
Figure 3-2	How to Remove Knockouts	28
Figure 3-3	Mounting Flush in a New Panel Cutout	29
Figure 3-4	Mounting Flush on a Surface (of Panel or Wall)	31
Figure 3-5	Ferrite Filter Locations (CE Mark)	34
Figure 3-6	AC Line Power Wiring	36
Figure 3-7	Input 1 Wiring	38
Figure 3-8	Input 2 Wiring	40
Figure 3-9	Recorder Output Connections for 24V Power Supply	42
Figure 3-10	Control Output Wiring - 1 or 2 Pen Models	44
Figure 4-1	DR4200 EV Prompt Hierarchy	46
Figure 5-1	Basic Chart Plate Components	74
Figure 5-2	Typical Chart Step Pattern	76
Figure 5-3	Setting Chart Time to Time Index	77
Figure 5-4	Operator Interface	82
Figure 5-5	Replacing the Ink Cartridge and Chart	96
Figure 6-1	Location of the Input Connections on the Input Boards	99
Figure 6-2	Calibration Set Up Diagram for Thermocouple Inputs Using an Ice Bath	102
Figure 6-3	Calibration Set Up Diagram for RTD Inputs	103
Figure 6-4	Calibration Set Up Diagram for Millivolts, Volts, and Milliamps Inputs ..	104
Figure 6-5	Test Equipment Connections for Calibrating Current Output	108
Figure 8-1	Door Assembly	138
Figure 8-2	Chart Plate Assembly	140
Figure 8-3	Basic Recorder Components Without Options	141
Figure 8-4	Recorder Components Associated With Options	142
Figure A-1	Pen Traces (Proportional Plus Manual Reset)	146
Figure A-2	Pen Traces (Proportional Plus Reset and/or Plus Rate)	146
Figure B-1	Transformer for Digital Equipment	154
Figure B-2	Transient Suppression in Inductive Coils	156
Figure B-3	Contact Noise Suppression	157
Figure B-4	DC Load Noise Suppression	158

Tables

Table 1-1	Function of Keys.....	7
Table 2-1	AC Line Power Wiring	11
Table 2-2	Jumper W3 or W4 Positions (Burnout).....	12
Table 2-3	Actuation Switch Settings and Jumper Locations.....	13
Table 2-4	Procedure for Mounting Control Output Printed Circuit Board	17
Table 2-5	Control /Alarm Function Summary	19
Table 2-6	Control Output Setup Procedure	20
Table 3-1	Operating Limits and Condensed Specifications.....	24
Table 3-2	Mounting Flush in a New Panel Cutout.....	29
Table 3-3	Mounting Flush on a Surface (of Panel or Wall).....	30
Table 3-4	Permissible Wiring Bundling.....	33
Table 3-5	AC Line Power Wiring	35
Table 3-6	Input 1 Wiring	37
Table 3-7	Input 2 Wiring	39
Table 3-8	Power Supply Output Wiring	41
Table 3-9	Relay Output Wiring – 1 or 2 Pen Models	43
Table 4-1	Configuration Tips	48
Table 4-2	Configuration Procedure.....	49
Table 4-3	Chart Parameters Group	51
Table 4-4	Pen Parameters Group	52
Table 4-5	Input Parameters.....	53
Table 4-6	Totalizer Parameter Group Definitions	57
Table 4-7	Output Group Function Prompts	59
Table 4-8	Control Parameter Group	60
Table 4-9	Tuning Parameters Group.....	64
Table 4-10	Cycle Parameters Group.....	66
Table 4-11	Alarms Group Definitions.....	67
Table 4-12	Lockout Group Definitions	70
Table 5-1	Preparing the Recorder for Operation.....	74
Table 5-2	Running the Self-Test.....	75
Table 5-3	Set Chart Time and Apply Power Procedure.....	77
Table 5-4	Power Up Diagnostic Tests	78
Table 5-5	Procedure for Testing the Displays and Keys	79
Table 5-6	Procedure for Starting Up the Recorder.....	80
Table 5-7	Meaning of Indicators	83
Table 5-8	Lower Display Key Parameter Prompts.....	84
Table 5-9	Error Messages	85
Table 5-10	Operating Mode Definitions.....	87
Table 5-11	Procedure for Selecting Automatic or Manual Mode.....	88
Table 5-12	Changing the Control Setpoints.....	89
Table 5-13	Procedure for Displaying or Changing the Alarm Setpoints	90
Table 5-14	Procedure for Resetting the Totalizer.....	91
Table 5-15	Changing Input Type and Restore Factory or Field Calibration Values ..	92
Table 5-16	Maximizing Pen Life	94
Table 5-17	Replacing the Ink Cartridge.....	95
Table 5-18	Replacing the Chart.....	96
Table 6-1	Voltage and Resistance Equivalents for 0% and 100% Range Values...	98
Table 6-2	Disconnect the Field Wiring.....	99
Table 6-3	Equipment Needed.....	100
Table 6-4	General Set Up Procedure	101
Table 6-5	Set Up Wiring Procedure for Thermocouple Inputs Using an Ice Bath .	102
Table 6-6	Set Up Wiring Procedure for RTD Inputs	103
Table 6-7	Set Up Wiring Procedure for Millivolts, Volts, and Milliamps Inputs	104
Table 6-8	Input Calibration Procedure Sequence.....	105

Tables

Table 6-9	Set Up Wiring Procedure Current Proportional Output.....	108
Table 6-10	Current Proportional Output Calibration Procedure.....	109
Table 7-1	Procedure for Identifying the Software Version	114
Table 7-2	Power-up Tests.....	115
Table 7-3	Procedure for Displaying the Status Tests Results.....	116
Table 7-4	Error Message Prompts	117
Table 7-5	Visual Failure Symptoms	119
Table 7-6	Troubleshooting Recorder Failure Symptoms	120
Table 7-7	Troubleshooting Pen Trace Failure Symptoms.....	121
Table 7-8	Troubleshooting Chart Rotation Failure Symptoms.....	121
Table 7-9	Troubleshooting Erratic Pen Movement Symptoms.....	122
Table 7-10	Troubleshooting Keyboard and/or Display Failure Symptoms.....	123
Table 7-11	Troubleshooting Current Proportional Output Failure Symptoms	123
Table 7-12	Troubleshooting Relay Output Failure Symptoms	124
Table 7-13	Troubleshooting External Alarm Function Failure Symptoms.....	125
Table 7-14	Replacing the No. 1 Pen Arm	127
Table 7-15	Replacing the No. 2 Pen Arm	128
Table 7-16	Replacing the Servo Plate	129
Table 7-17	Replacing the Chart Motor.....	129
Table 7-18	Replacing the Main Printed Circuit Board.....	130
Table 7-19	Replacing the Display and Keyboard Printed Circuit Board.....	131
Table 7-20	Check the Mechanical Pen Alignment	132
Table 7-21	Electrical Pen Alignment at Span and Zero	133
Table 8-1	Door Assembly Parts	138
Table 8-2	Chart Plate Assembly Parts.....	140
Table 8-3	Basic Recorder Parts without Options	141
Table 8-4	Recorder Parts Associated with Options	142
Table A-1	Manual Tuning Procedure for Simplex Control	144
Table A-2	Manual Tuning Formulas	145
Table B-1	External Wiring.....	152
Table B-2	MOV Devices.....	155
Table B-3	Coil Voltage vs Resistor Voltage Rating	156
Table C-1	Reference Accuracy.....	159
Table D-1	10-inch Single Range Chart Part Numbers.....	161
Table D-2	10-inch Dual Range Chart Part Numbers	167

Acronyms

EMI	electromagnetic interference
EV	Enhanced Version
HID	high intensity discharge
MOV	Metal Oxide Varistor
PCB	Printed Circuit Board
RC	resistance-capacitance
RFI	radio frequency interference
RH	Relative Humidity
SCR	Silicon controlled rectifier

Section 1 – Overview

1.1 Introduction

Function

The DR4200 Enhanced Version (EV) Recorder is a one or two pen microprocessor-based circular chart recorder that generates dependable pen drawn analog traces on preprinted 10-inch (250 mm) charts.

User configuration allows setting and/or altering operating parameters to fit your application requirements. You configure the recorder by positioning jumpers and DIP switches on a printed circuit board and by entering configuration parameters into the recorder. The configuration parameters include type of input, chart speed, chart range, alarm settings, control settings, and others.

Both one-pen and two-pen models accept inputs from any one of a variety of sensors and transmitters within the configurable range limits.

CE Conformity (Europe)

Indicated models of this product are in conformity with the protection requirements of the following European Council Directives: **73/23/EEC**, the Low Voltage Directive, and **89/336/EEC**, the EMC Directive. Conformity of this product with any other “CE Mark” Directive(s) shall not be assumed.

Deviation from the installation conditions specified in this manual, and the special conditions for CE conformity in Section 3.1, may invalidate this product’s conformity with the Low Voltage and EMC Directives.

ATTENTION

The emission limits of EN 50081-2 are designed to provide reasonable protection against harmful interference when this equipment is operated in an industrial environment. Operation of this equipment in a residential area may cause harmful interference. This equipment generates, uses, and can radiate radio frequency energy and may cause interference to radio and television reception when the equipment is used closer than 30 meters (98 feet) to the antenna(e). In special cases, when highly susceptible apparatus is used in close proximity, the user may have to employ additional mitigating measures to further reduce the electromagnetic emissions of this equipment.

1.1 Introduction, Continued

Microprocessor controlled recording

Both the chart and the pen are driven by stepper motors controlled by the microprocessor. Since chart speed is configurable, you can easily alter the chart speed through the keyboard.

The microprocessor uses the configured chart range data as well as the input data to determine proper pen position. The stepper motor accurately positions the pen drive.

Input processing

The input can be one of any standard low-level electrical signals. The input type and range are configurable and can be expanded and compressed within their limits to meet specific measurement needs.

You can select upscale or downscale sensor break protection for most actuations. Analog and digital filters with fixed time constants provide input signal smoothing.

Construction

All DR4200 recorders are housed in a molded case which can be panel or surface mounted. A glass or acrylic windowed, gasketed door protects internal components from harsh environments while allowing easy access to the chart.

Digital Controller

The DR4200 EV recorder controller includes an integral microprocessor-based, single-loop, PID controller. A variety of output types, including time duplex variations for heat-cool applications, lets users select the output that is right for their final control element. Depending on the output type, users can configure the control action as ON-OFF, PID-A, or PD with a manual reset. As with the record functions, English language prompts quickly guide users through the entry of all the controller's configurable parameters.

1.2 Model Number and Hardware Description

Introduction

The DR4200 circular chart recorder is available in one-pen and two-pen models, with or without control or alarm outputs.

Since this manual covers all models, we recommend that you decode your recorder's model number first as described below so you can easily identify pertinent instructions in this manual.

Decoding the recorder's model number

Copy the model number that appears on the label on the front of the recorder's chart plate into the boxes shown in Figure 1-1. Use the model number "Table" code definitions to decode your recorder's given hardware characteristics.

www.DataSheet4U.com

Figure 1-1 Model Number Interpretation

DR4200 EV

Number of Pens		Table II - Options	
Code	Definition	Code	Definition
1	1 Pen	G-----	Gray door
2	2 Pens	B-----	Blue door
		J-----	Heavy duty gray door
		H-----	Heavy duty blue door
		- G-----	Glass window
		- P-----	Acrylic window
		-- O-----	Standard latch (N/A with heavy duty door)
		-- K-----	Door lock (Standard on heavy duty door)
		-- T-----	Heavy duty latch
		--- O-----	No approvals
		--- U-----	UL listing
		--- C-----	CSA certification
		--- B-----	UL and CSA
		--- K-----	CE Mark
		--- L-----	CE Mark + UL Listing
		--- M-----	CE Mark + CSA Listing
		--- N-----	CE Mark + UL + CSA
		----- O --	No totalization
		----- 1 --	One loop totalization
		----- 2 --	Two loop totalization
		----- O O	No selection

Table I - Control Output	
Pen One	
Code	Definition
0	None
1	1 Control, includes 2 relays*
2	2 Alarm Relays**
3	1 24V power supply
Pen Two	
-0	None
-1	1 Control, includes 2 relays*
-2	2 Alarm Relays**
-3	1 24V power supply

* If any type control (on/off, current, or time prop. simplex) is used on a pen, only one alarm relay is available for that pen (no. 2 relay). Time prop. duplex control will require two relays, and no relays are available for alarming on that pen.

** Alarm one relay can be used for on/off control.

22391

ATTENTION

Every DR4200 Recorder has all the available input actuations stored in its non-volatile memory. Therefore, you must select the input actuation in the field by setting DIP Switches, selecting jumper positions, and making input wiring connections, as applicable.

Continued on next page

1.2 Model Number and Hardware Description, Continued

Component location

Refer to the views in Figure 1-2 (DR4200EV1) and Figure 1-3 (DR4200EV2) to match given hardware characteristics (Table selections) with the location of actual hardware components in your recorder. This will help you determine applicable input/output wiring needs as well as identify appropriate set-up tasks to prepare the recorder for operation later.

To view actual components inside your recorder:

- Push in the button on the recorder door and swing the door open.
- Loosen the captive screw on the right-hand side of the chart plate and swing the chart plate out.

www.DataSheet4U.com

Model DR4200EV1

Figure 1-2 is a view of the hardware components versus "Table" selections for Model DR4200EV1.

Figure 1-2 Hardware Components for Model DR4200EV1

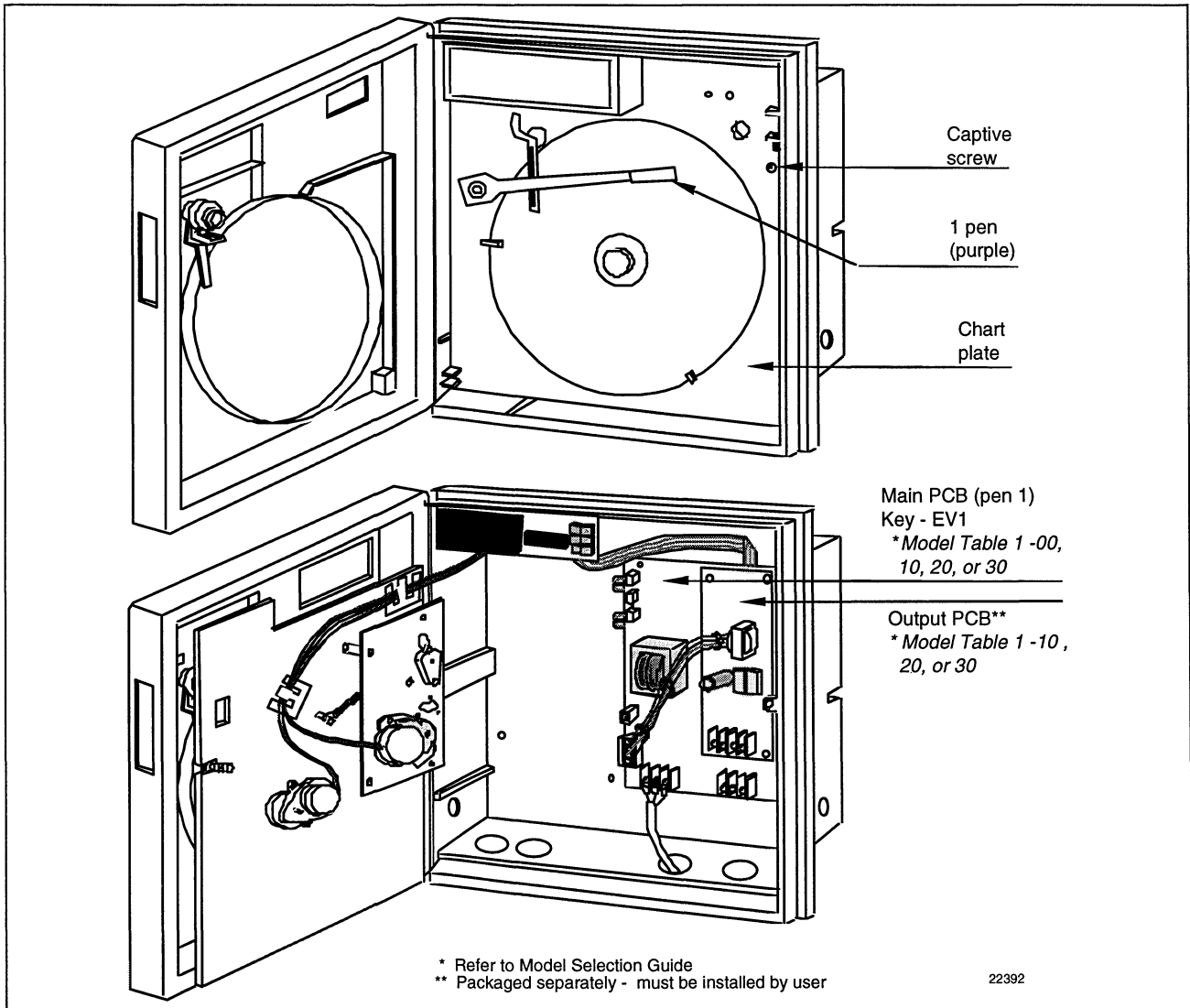

Continued on next page

1.2 Model Number and Hardware Description, Continued

Model DR4200EV2

Figure 1-3 is a view of the hardware components versus "Table" selections for Model DR4200EV2.

Figure 1-3 Hardware Components for Model DR4200EV2

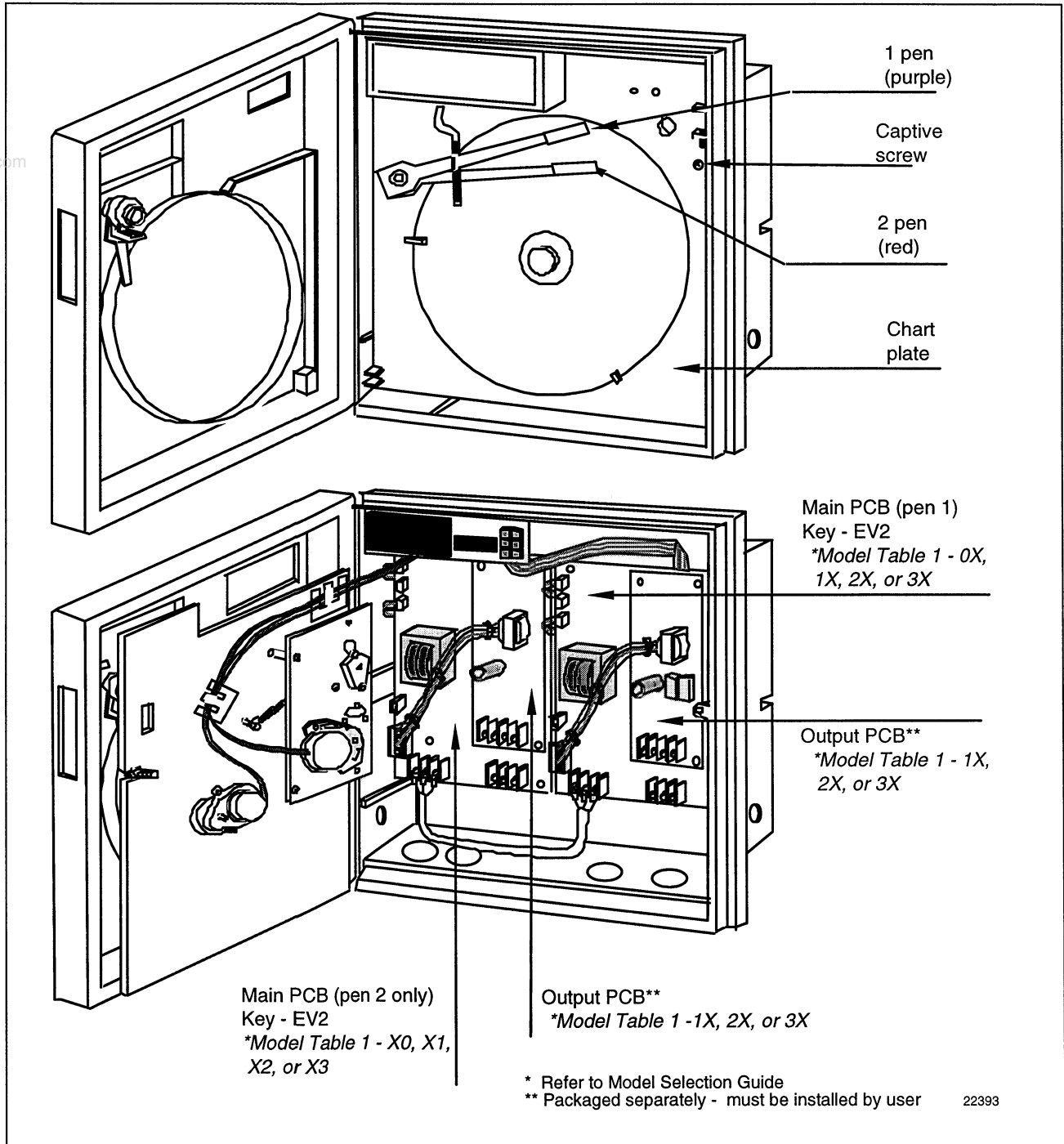

1.3 Operator Interface

Displays and Indicators

Figure 1-4 shows the operator interface and defines the displays and indicators. The function of the keys is described in Table 1-1.

Figure 1-4 Operator Interface

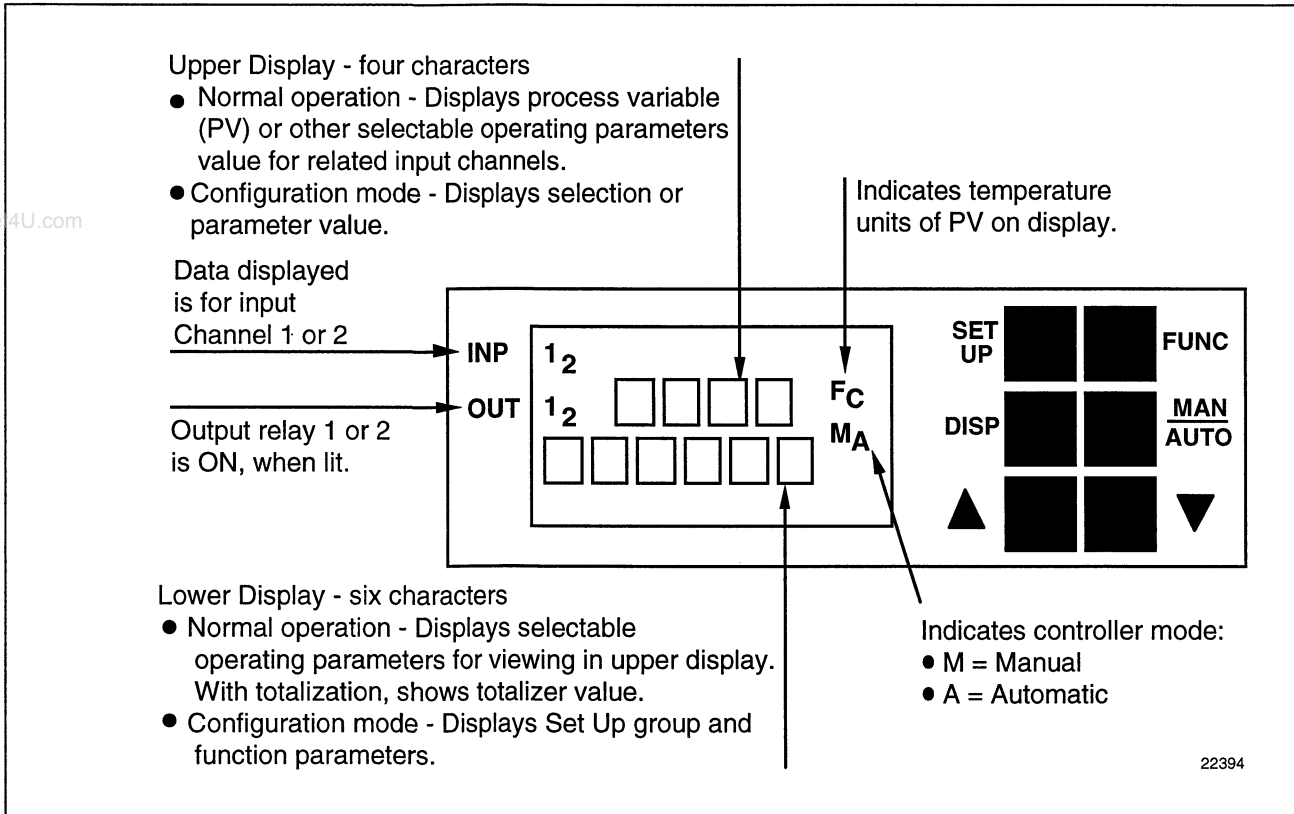









1.3 Operator Interface, Continued

Key functions

Table 1-1 shows each key on the operator interface and defines its function.

Table 1-1 Function of Keys

Key	Function
	<ul style="list-style-type: none"> Places the recorder in the Configuration Set Up group select mode. Sequentially displays Set Up groups and allows the  key to display individual functions in each Set Up group.
	<ul style="list-style-type: none"> Used in conjunction with the  key to select the individual functions of a selected Configuration Set Up group. Used to toggle between input channel selection for display - 2 pen recorder model only. Used during field calibration procedure.
	<ul style="list-style-type: none"> Selects an operating parameter to be shown in the lower display, value viewed in upper display <ul style="list-style-type: none"> INP1 = Input Channel 1 OUT1 = Output (Pen 1 Control) SP1 = Local Setpoint (Pen 1 Control) DEV1 = PV Deviation (Pen 1 Control) XXXXXX = Input Channel 1 INP2 = Input Channel 2 OUT2 = Output (Pen 2 Control) SP2 = Local Setpoint (Pen 2 Control) DEV2 = PV Deviation (Pen 2 Control) XXXXXX = Input Channel 2 XXXXXX = Totalizer Value in lower display Input is in upper display
	<p>For recorder model with control:</p> <ul style="list-style-type: none"> Alternately selects: <ul style="list-style-type: none"> AUTO Lower display automatically displays setpoint value in engineering units. MAN Lower display automatically indicates output in %.
	<ul style="list-style-type: none"> Increases the setpoint, output, or configuration values displayed.
	<ul style="list-style-type: none"> Decreases the setpoint, output, or configuration values displayed.

1.4 Pre-Setup Operational Check

Summary

The DR4200 EV recorder includes a self-test feature that checks the operational status of major recorder functions. You can run the self-test before you Setup the recorder for your application requirements. This test will verify that the recorder is operating properly as received from the factory.

For the procedure to run the self-test, refer to subsection 5.3- *Running the Optional Self-Test*.

Section 2 – Recorder Set Up Tasks

2.1 Introduction

Overview

This section contains the setup tasks required to prepare your recorder for operation. These configurable functions are:

- checking the line voltage requirements,
- selecting upscale or downscale burnout, and
- selecting the input actuation type/range.

Each separate task includes a general overview of that task and a procedure for you to follow to accomplish it.

Figure 2-1 is an overview of factory settings for jumper and DIP switches as well as the general location of components on the main printed circuit board.

If you have an optional control printed circuit board, this section also includes the setup tasks required to prepare the control portion of your recorder. These configurable functions are:

- mounting the control printed circuit board,
- setting the current/relay functions (Model Table 1-IX or XI), and
- setting the relay only action (Model Table 1-2X or X2).

Figure 2-6 is an overview of the factory settings for jumpers as well as the general location of components on the control printed circuit board.

ATTENTION You can run the pre-operational check given in subsection 5.3- *Running the Optional Self-Test* before you setup the recorder and if desired, you can mount the recorder as outlined in *Section 3 - Installation*.

What's in this section? The following topics are covered in this section:

	Topic	See Page
2.1	Introduction	9
2.2	Configuration Selections for Recording	10
2.3	Optional Control Output Setup	15

2.2 Configuration Selections for Recording

Introduction

There are three configuration selections that you must make or check to get the recorder to operate in accordance with your application needs. They are

- Line Voltage
- Burnout
- Input Actuation

Jumper and DIP switch locations

Figure 2-1 is an overview of the factory settings and DIP switch locations for these functions. Each location references a figure and/or table that contain the information you need to check or set the switches and jumpers.

Figure 2-1 DIP Switch and Jumper Locations

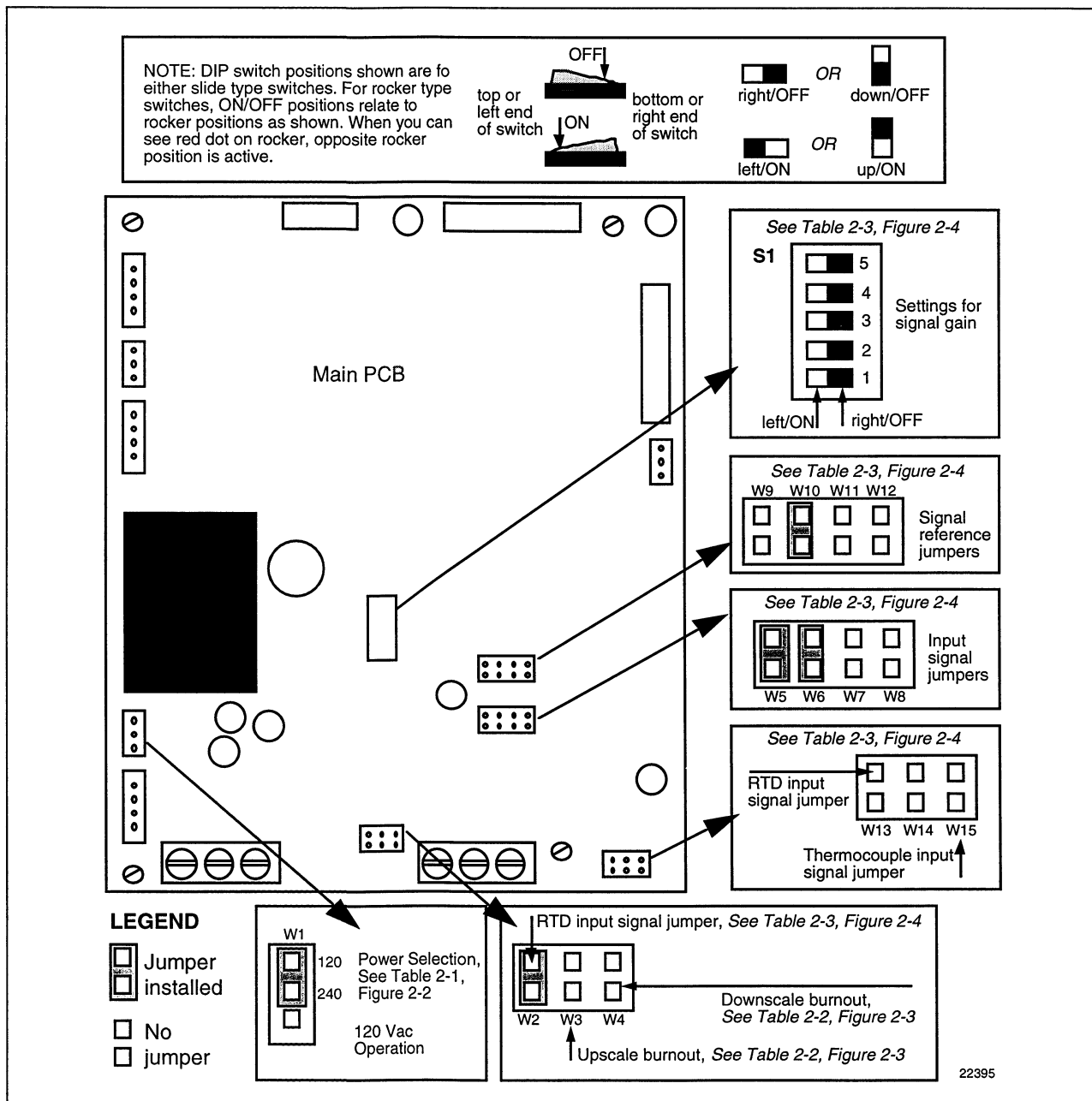

2.2 Configuration Selections for Recording, Continued

Check line voltage requirements

Refer to Figure 2-2 and follow the procedure in Table 2-1 to make sure the recorder's power requirement matches the available AC line power.

Table 2-1 AC Line Power Wiring

Step	Action						
1	Open the recorder door. Loosen the captive screw in the chart plate and swing the plate out.						
2	Locate Jumper W1 next to the transformer on the left side of the Main printed circuit board for Pen #1. See Figure 2-2.						
3	Position the jumper as follows: <table border="1" style="margin-left: 40px;"> <thead> <tr> <th>Line Voltage</th> <th>Jumper Location</th> </tr> </thead> <tbody> <tr> <td>120Vac 50/60 Hz</td> <td>120 (factory setting)</td> </tr> <tr> <td>240Vac 50/60 Hz</td> <td>240</td> </tr> </tbody> </table>	Line Voltage	Jumper Location	120Vac 50/60 Hz	120 (factory setting)	240Vac 50/60 Hz	240
Line Voltage	Jumper Location						
120Vac 50/60 Hz	120 (factory setting)						
240Vac 50/60 Hz	240						
CAUTION	Be sure Jumper 1 on the Main printed circuit board for Pen #2 is in the same position.						
4	If the jumper W1 position is set for 240, be sure to note power requirement on the label on the front of the chart plate.						

Figure 2-2 Jumper W1 Positions (AC Line Power)

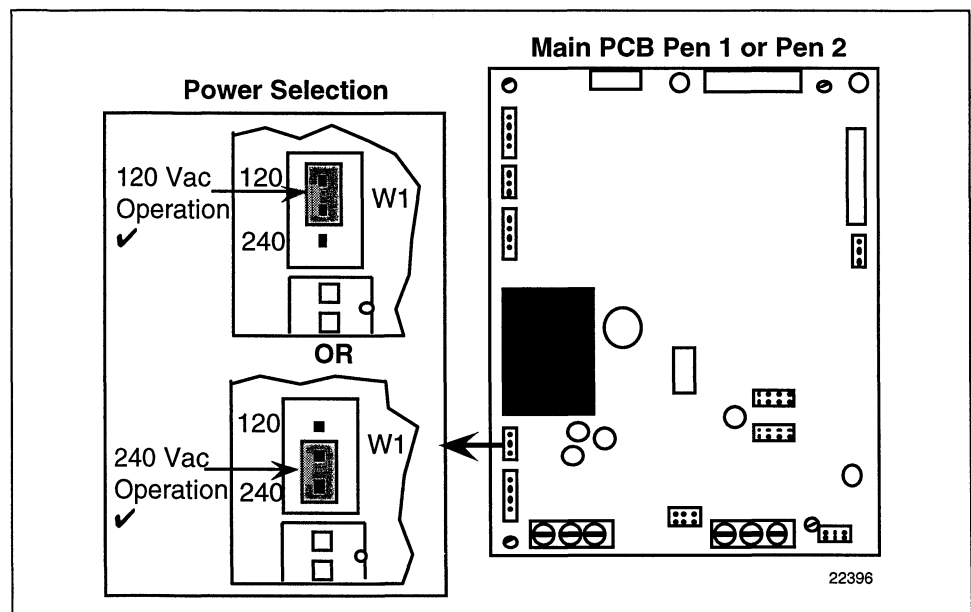

2.2 Configuration Selections for Recording, Continued

Selecting upscale or downscale burnout

You can select Upscale or Downscale burnout for *Thermocouple* or *Millivolt* actuations. This means that the pen will be driven to its full upscale or downscale position if the Process Variable (PV) goes out-of-range (open input sensor), or the recorder detects a self-check failure.

ATTENTION You can select downscale burnout for RTD, Voltage, and mA actuations, but there is no guarantee that an out-of-range PV condition will be detected.

Refer to Figure 2-3 and follow the procedure in Table 2-2 to position jumpers W3 or W4 to select upscale or downscale burnout.

Table 2-2 Jumpers W3 or W4 Positions (Burnout)

Step	Action								
1	Open the recorder door. Loosen the captive screw in the chart plate and swing the plate out.								
2	Locate W2, W3 and W4 jumpers near the bottom of the Main printed circuit board for Pen #1 (see Figure 2-3).								
3	Position the jumper as follows... <table border="0" style="width: 100%; border-collapse: collapse;"> <tr> <td style="text-align: center; border-bottom: 1px solid black;"><u>Burnout Direction</u></td> <td style="text-align: center; border-bottom: 1px solid black;"><u>Jumper Location</u></td> </tr> <tr> <td style="text-align: center;">Upscale</td> <td style="text-align: center;">W3</td> </tr> <tr> <td style="text-align: center;">Downscale</td> <td style="text-align: center;">W4</td> </tr> <tr> <td style="text-align: center;">None</td> <td style="text-align: center;">None (factory setting)</td> </tr> </table>	<u>Burnout Direction</u>	<u>Jumper Location</u>	Upscale	W3	Downscale	W4	None	None (factory setting)
<u>Burnout Direction</u>	<u>Jumper Location</u>								
Upscale	W3								
Downscale	W4								
None	None (factory setting)								
4	Repeat steps 2 and 3 for Pen #2 Main printed circuit board								

Figure 2-3 Jumpers W3/W4 Positions (Burnout)

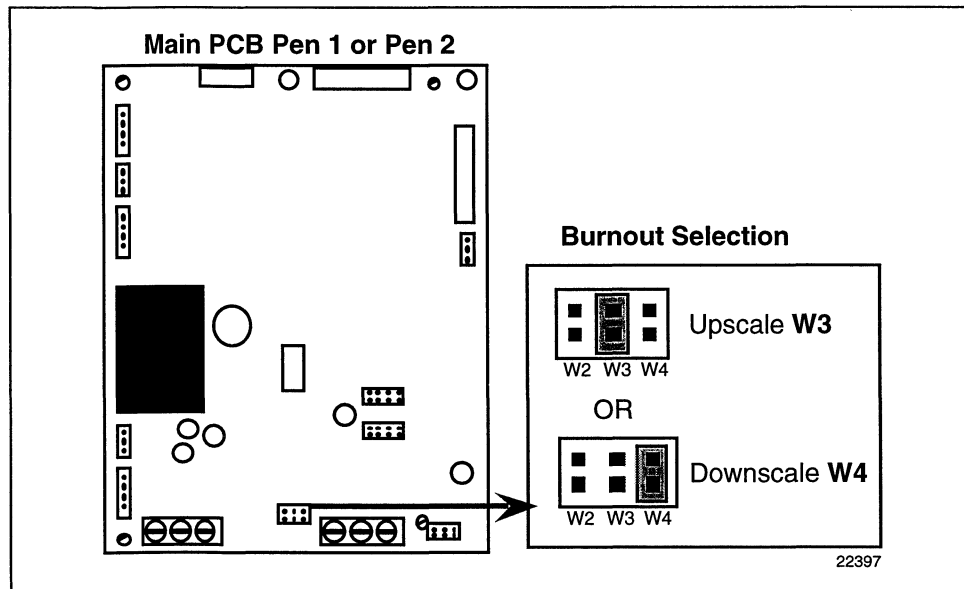

2.2 Configuration Selections for Recording, Continued

Selecting the input actuation type/range input and signal

You must configure the recorder to accept the desired input actuation for the given pen by setting DIP switch S1 positions for signal gain and positioning the applicable input and signal jumpers on the Main printed circuit boards for Pen #1 and Pen #2, if applicable.

- Refer to Table 2-3 to identify DIP switch settings and range jumper positions for the desired actuation type.
- Refer to the Figure 2-4 the DIP Switch settings and jumper positions that are noted in Table 2-3 for the selected actuation.
- Note the configured actuation type for each pen on the wiring label on the back of the chart plate.

ATTENTION

Be sure that a matching sensor input is wired to the input terminals and you select the same input type through IN TYP prompt in setup group "INPUT" (see *Section 4 - Configuration*).

DIP switch settings and jumper locations Table 2-3 is a list of actuations, S1 switch positions and settings, input jumper locations, and signal reference jumper locations.

Table 2-3 Actuation Switch Settings and Jumper Locations

Actuation	Type	Input Jumper Locations	Signal Reference Jumper Locations	S1 Switch Positions & Settings (Leave position 2 set to OFF)			
				1	3	4	5
Thermocouple	B	W6, W15	W11	OFF	ON	OFF	OFF
Thermocouple	E	W6, W15	W9	ON	OFF	OFF	ON
Thermocouple	E (Low)	W6, W15	W10	OFF	OFF	ON	OFF
Thermocouple	J	W6, W15	W10	OFF	OFF	ON	OFF
Thermocouple	J (Low)	W6, W15	W11	OFF	ON	OFF	OFF
Thermocouple	K	W6, W15	W9	ON	OFF	OFF	ON
Thermocouple	K (Low)	W6, W15	W11	OFF	ON	OFF	OFF
Thermocouple	Ni-Ni Moly	W6, W15	W9	ON	OFF	OFF	ON
Thermocouple	Nicrosil-Nisil	W6, W15	W10	OFF	OFF	ON	OFF
Thermocouple	R	W6, W15	W11	OFF	ON	OFF	OFF
Thermocouple	S	W6, W15	W11	OFF	ON	OFF	OFF
Thermocouple	T	W6, W15	W11	OFF	ON	OFF	OFF
Thermocouple	T (Low)	W6, W15	W11	OFF	ON	OFF	OFF
Thermocouple	W5W26	W6, W15	W10	OFF	OFF	ON	OFF
RTD*	100 ohm*	W2*, W6*, W13*	W10*	OFF*	OFF*	ON*	OFF*
RTD	100 ohm (Low or T)	W2, W6, W13	W10	OFF	OFF	ON	OFF
Linear	4-20 mA	W5, W8	W10	OFF	OFF	ON	OFF
Linear	0-10 mV	W6	W12	OFF	OFF	OFF	OFF
Linear	0-100 mV	W6	W9	ON	OFF	OFF	ON
Linear	0-200 mV	W7	W9	ON	OFF	OFF	ON
Linear	0-1 Vdc	W8	W12	OFF	OFF	OFF	OFF
Linear	0-5 Vdc	W8	W10	OFF	OFF	ON	OFF
Linear	1-5 Vdc	W8	W10	OFF	OFF	ON	OFF
Linear	0-10 Vdc	W8	W9	ON	OFF	OFF	ON

* Factory Setting

Continued on next page

2.2 Configuration Selections for Recording, Continued

DIP switch settings and jumper locations, continued Figure 2-4 is a graphic view of the S1 DIP switch settings and jumper locations.

Figure 2-4 DIP Switch and Jumper Locations for Actuation Selections

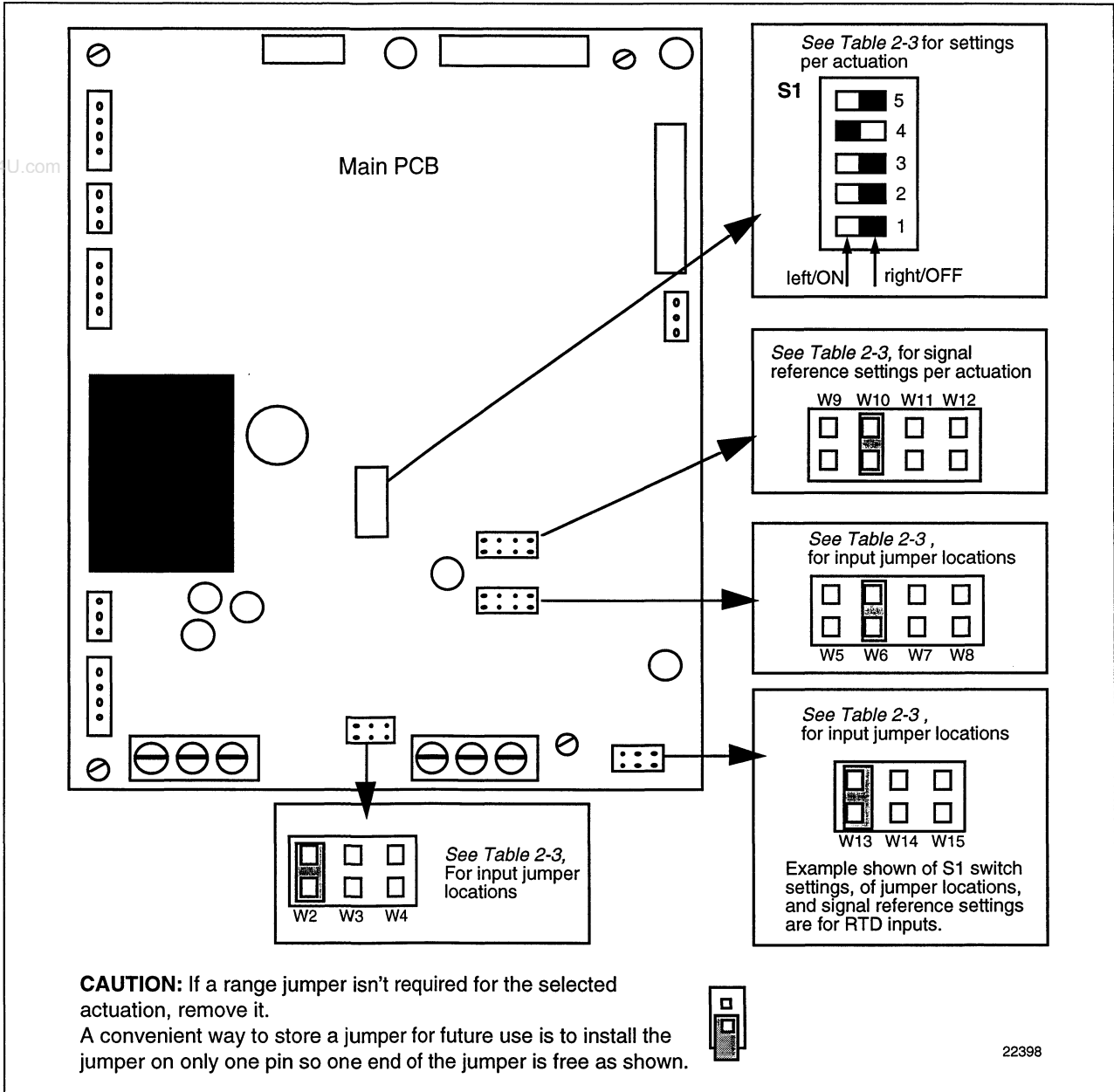

2.3 Optional Control Output Setup

Introduction

If you ordered a recorder with control output, a separately packaged control printed circuit board is supplied with your recorder. You must mount the control printed circuit board on the Main printed circuit board. Refer to Figure 2-5 and follow the procedure in Table 2-4 to mount the control output board.

Depending on the model number you've ordered, you configure the hardware and software for your control output function.

Printed Circuit board number 30756087-001, Model Table 1 = 1X or X1

- configure the control output software as current or relay,
- set the jumpers on the control output PCB for current output control or set the relay action jumpers as N.O. (normally open) or N.C. (normally closed).

Printed Circuit board number 30756087-002, Model Table 1 = 2X or X2

- set the relay action jumpers on the control printed circuit board as N.O. (normally open) or N.C. (normally closed).

Printed Circuit board number 30756087-003, Model Table 1 = 3X or X3

- no settings required.

CAUTION Make sure you have set all the jumper positions on the main printed circuit board before proceeding. See Figure 2-5.

2.3 Optional Control Output Setup, Continued

Introduction

If you ordered a recorder with control output, you must mount the control Output printed circuit board on the Main printed circuit board. Refer to Figure 2-5 and follow the procedure in Table 2-4 to mount the board.

Figure 2-5 Mounting the Control Output Printed Circuit Board on the Main Printed Circuit Board

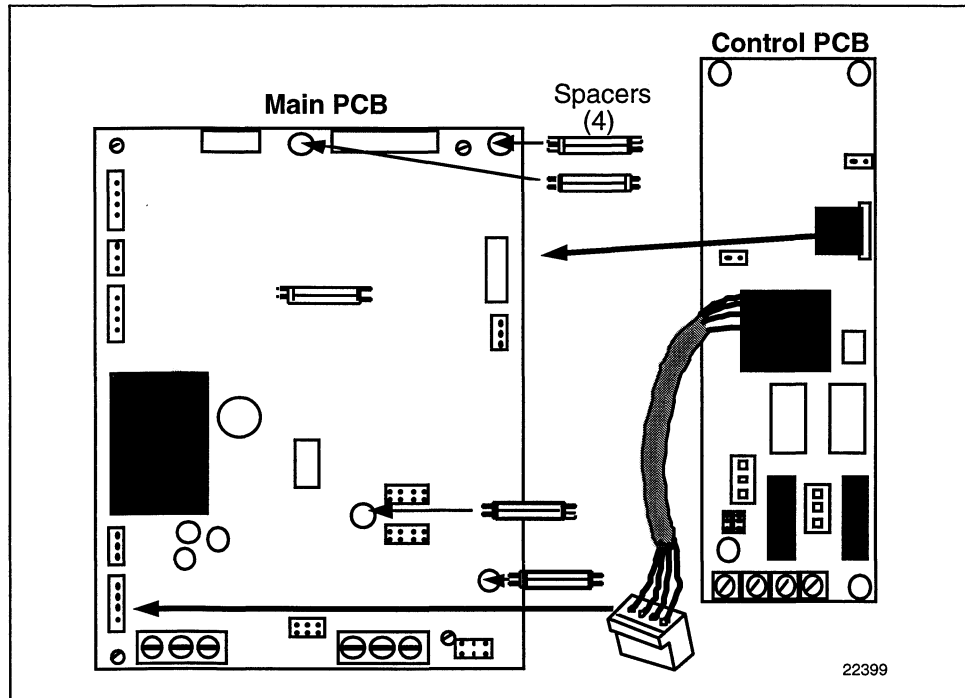

Continued on next page

2.3 Optional Control Output Setup, Continued

Mounting control output board procedure Follow the procedure in Table 2-4 to mount the Control Output printed circuit board.

ATTENTION If Table 1 in the model number is X1, X2 or X3, repeat this procedure for the Main printed circuit board for Pen #2.

Table 2-4 Procedure for Mounting Control Output Printed Circuit Board

Step	Action
1	Push the four plastic spacers (supplied with Control printed circuit board) into the holes on the right side of the Main printed circuit board for Pen #1 or Pen #2.
2	Hold the Control printed circuit board so that its mounting holes align with the spacers and plug the multi-pin connector from the Control printed circuit board into J5 connector on the Main printed circuit board. Be sure that the plug positions are aligned and matched with the pins on J5.
3	Push down on each corner of the Control printed circuit board in turn to seat the board on the spacers.
4	Plug the 4-pin connector from the transformer on the Control printed circuit board into the TB2 connector on the Main printed circuit board.

2.3 Optional Control Output Setup, Continued

DIP switch and jumper locations Figure 2-6 is a graphic view of the DIP switch and jumper locations on the Optional Control Output printed circuit board.

DR4200 EV Optional Control Output Circuit Boards:

- P/N 30756087-001 Current/Relay Output

Circuit board is completely populated with components. Install jumpers per Figure 2-6. Remove jumper W1/W2 if using current output control;. Remove W5/W6 if using relay output control.
- P/N 30756087-002 Relay Only Output

Upper left edge of board is unpopulated—includes only jumpers W1/W2 and W3/W4 for selection of N.O./N.C. relay operation. Refer to Figures 2-8 and 2-9 for additional configuration information.
- P/N 30756087-003 24 Vdc Transmitter Power Supply Output

Minimal component population includes only W9/W10, factory installed.

www.DataSheet4U.com

Figure 2-6 Jumper Locations on Optional Control Printed Circuit Board

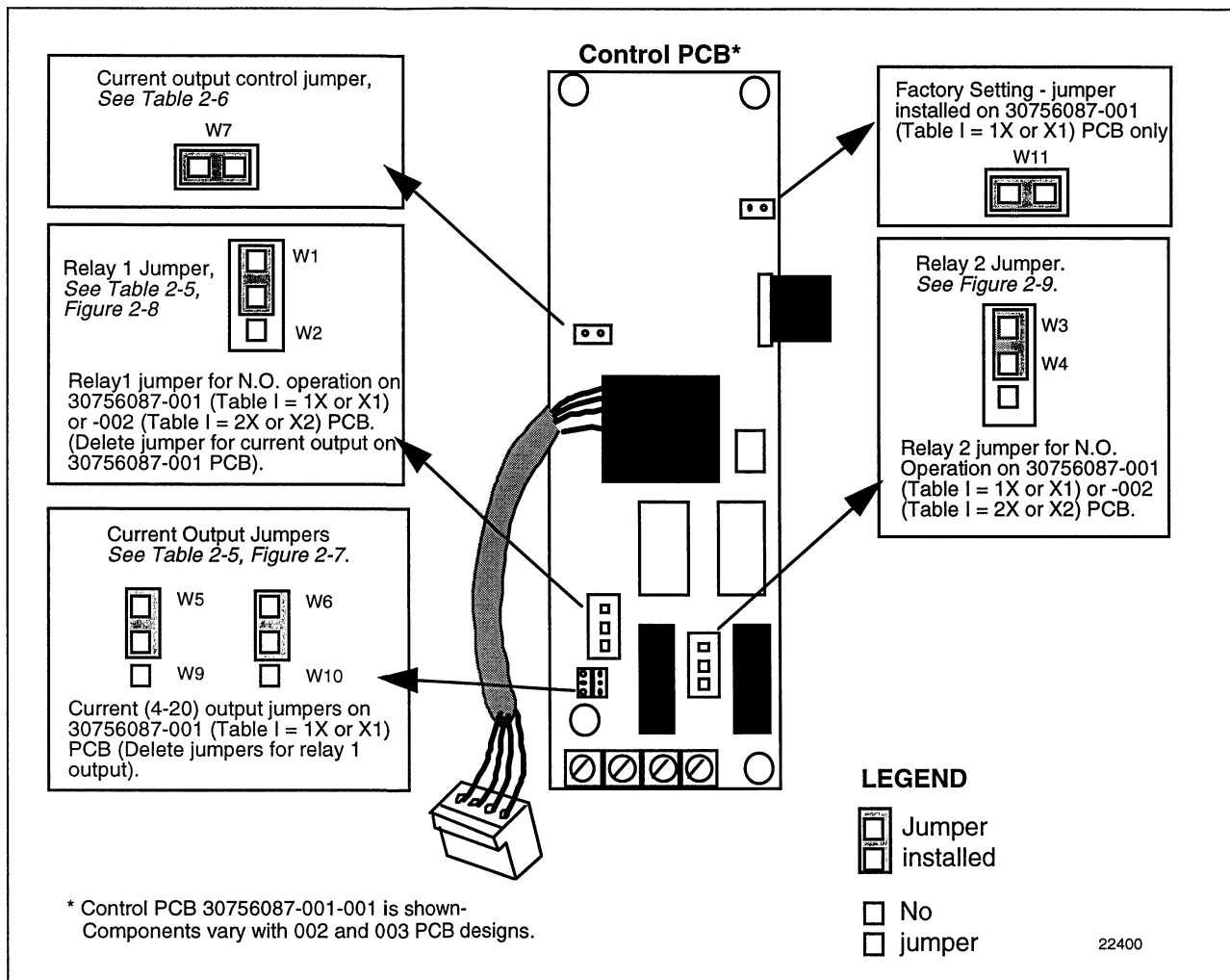

2.3 Optional Control Output Setup, Continued

Control output function summary On recorders with model number DR4200 EV1-10 or EV2-X1 (Table I = 1X or X1) you can set the control output to be:

- a 4-20 mA signal, or
- a relay contact from relay 1

by adding and deleting jumpers on control printed circuit board 30756087-001.

Depending on the hardware and software configuration selections you can set the control and/or alarm output functions to be one of the functions shown in Table 2-5.

Table 2-5 lists the control/alarm functions available plus the software and hardware configuration that is required to setup these functions.

Table 2-5 Control /Alarm Function Summary

Control/Alarm Function	Software Configuration			Hardware Configuration	
	Set Up Group Prompt	Function Prompt	Function Parameter Selection	Add W5 & W6 Delete W1/W2	Delete W5 & W6 Add W1/W2
Relay 1 is for ON-OFF control and relay 2 is for alarm #2	OUTPUT CONTRL CONTRL	OUTTYP OUTALG CTRALG	CTRL* RLY ONOF	NO	YES
Relay 1 is for time proportioning control and relay 2 is for alarm #2	OUTPUT CONTRL CONTRL	OUTTYP OUTALG CTRALG	CTRL RLY PIDA or PDMR	NO	YES
Relay 1 is for HEAT and relay 2 is for COOL in duplex time proportioning control	OUTPUT CONTRL CONTRL	OUTTYP OUTALG CTRALG	CTRL RLYD PIDA	NO	YES
Both relay 1 and relay 2 are for ON-OFF control	OUTPUT CONTRL CONTRL	OUTTYP OUTALG CTRALG	CTRL RLYD ONOF	NO	YES
On-OFF current control with relay 2 for alarm #2	OUTPUT CONTRL CONTRL	OUTTYP OUTALG CTRALG	CTRL CUR ONOF	YES	NO
Current proportioning control with relay 2 for alarm #2	OUTPUT CONTRL CONTRL	OUTTYP OUTALG CTRALG	CTRL CUR PIDA or PDMR	YES	NO
Relay 1 is for alarm #1 and relay 2 is for alarm #2	OUTPUT	OUTTYP	ALRM*	NO	YES

* Note that relay 1 output for Control PCB 30756087-002 (2X or X2) can be configured as ON-OFF control or alarm #1 by setting OUTTYP as CTRL or ALRM, respectively - jumpers W5 & W6 are not applicable.

2.3 Optional Control Output Setup, Continued

Control output setup procedure

Refer to Figure 2-7 and follow the procedure in Table 2-6 to select the desired control output action.

Table 2-6 Control Output Setup Procedure

Step	Action
1	Refer to Table 2-5 to identify jumpers for addition and deletion to get the desired control output action (Control PCB 30756087-001, Model Table I = X1 or 1X.)
2	Refer to Figure 2-6 for jumper location and add or delete jumpers as required for the desired control/alarm output. ATTENTION For current output control add W7 to tie common to ground or delete it for floating output.
3	Follow this procedure for the control output printed circuit board for pen #2, if applicable.
4	Note the configured control/alarm output function for each pen on the wiring label on the back of the chart plate for future reference.

Figure 2-7 Jumper Positions for Relay and Current Output on Control PCB 30756087-001

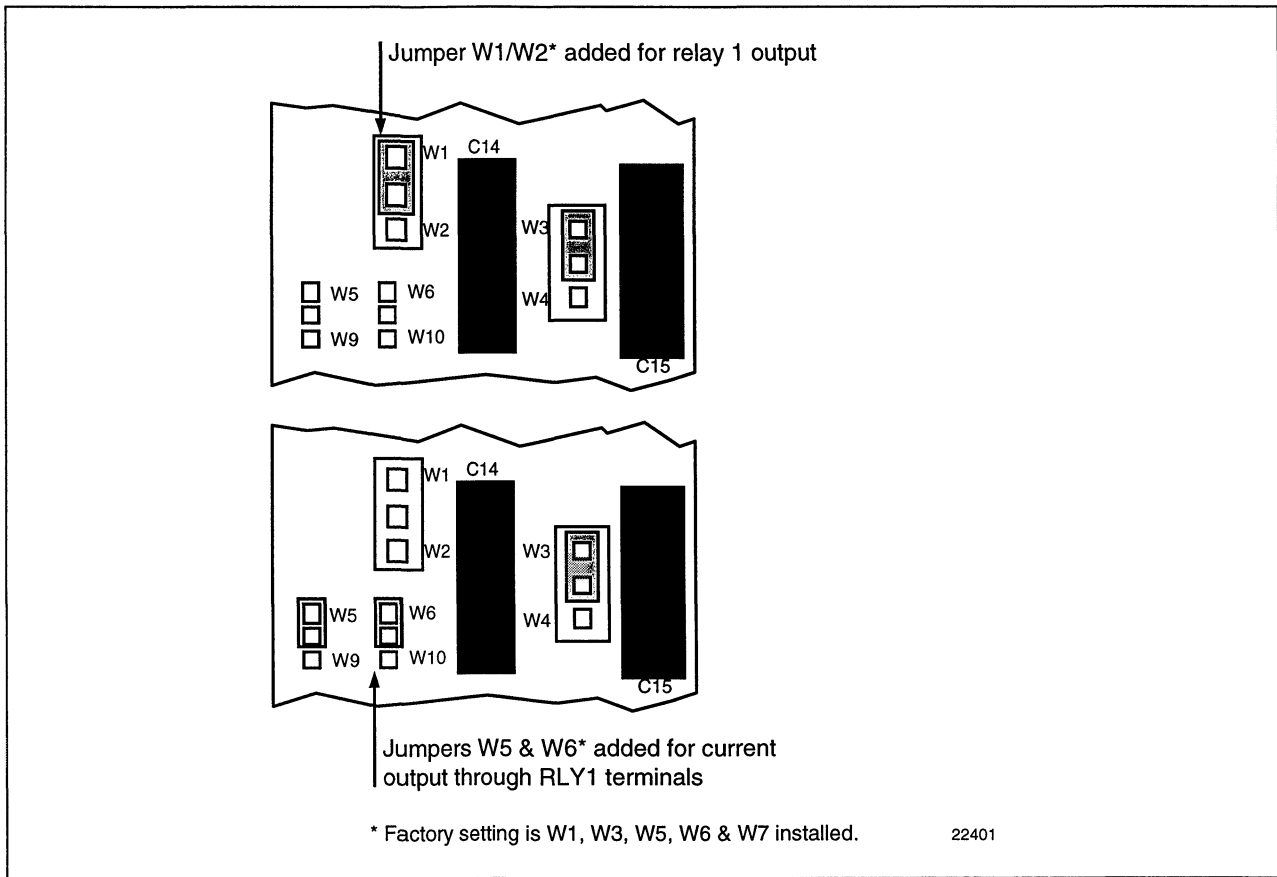

2.3 Optional Control Output Setup, Continued

Selecting relay #1 action Figure 2-8 is a graphic view of the jumper locations for setting relay #1 Action. Select the Output relay as N.O. or N.C. as shown in this figure. Note the selected action on the wiring label on the back of the chart plate for future reference.

ATTENTION Make sure W5/W6 jumpers have been removed for relay operation if installing P/N 30756087-001, Current/Relay output control board.

Figure 2-8 Jumper Locations for Relay #1 Action

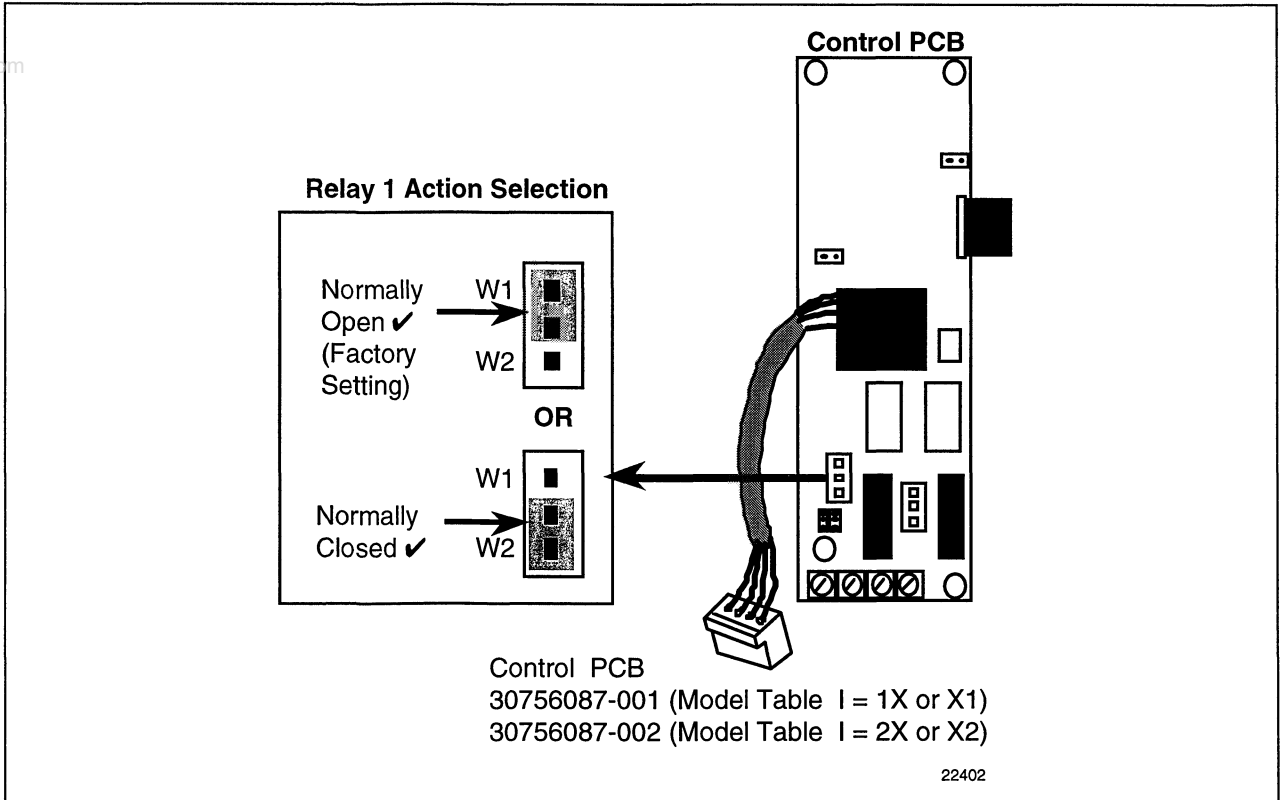

2.3 Optional Control Output Setup, Continued

Selecting relay #2 action

Figure 2-9 is a graphic view of the jumper locations for setting Relay #2 Action. Select the Output relay action as N.O. or N.C. as shown in this figure. Note the selected action on the wiring label on the back of the chart plate for future reference.

Figure 2-9 Jumper Locations for Relay #2 Action

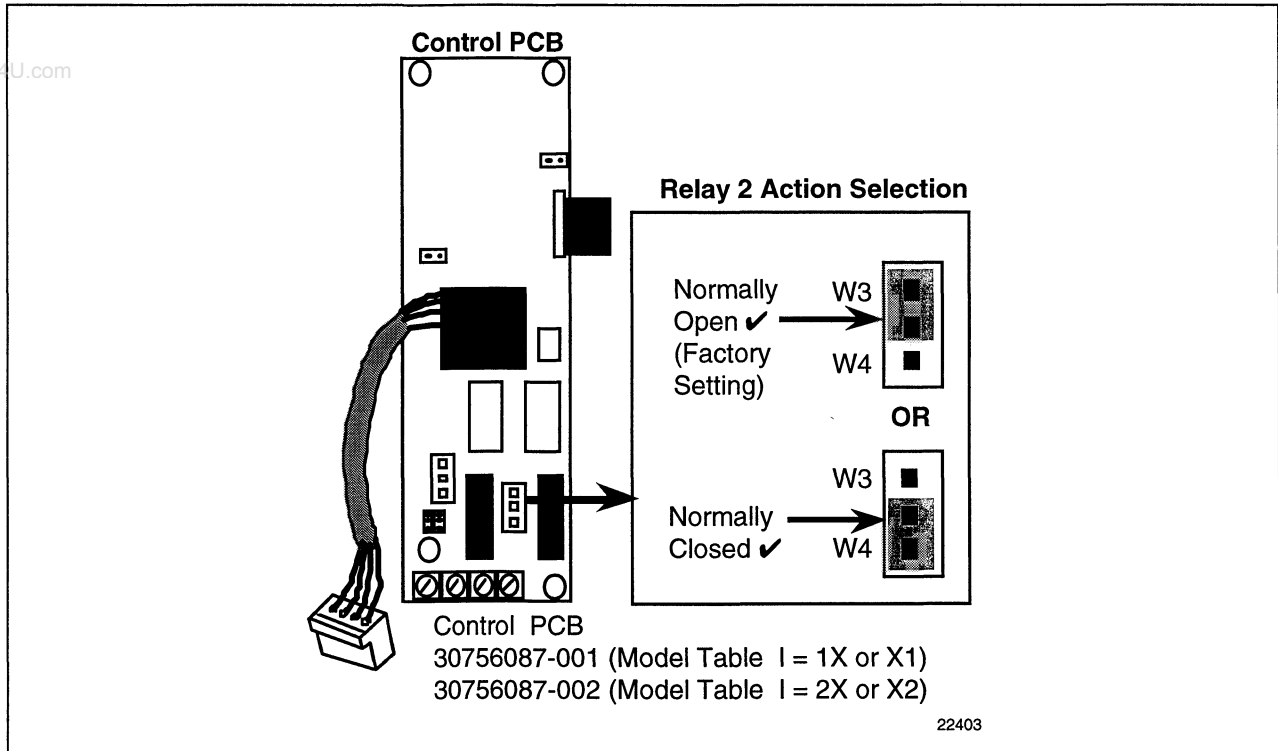

Section 3 – Installation

3.1 Overview

Introduction

Installation of the DR4200 Model EV Recorder consists of mounting and wiring the recorder according to the instructions given in this section.

Read the pre-installation information, check the model number interpretation in subsection 1.2 and become familiar with your model selections, then proceed with installation.

What's in this section?

This section contains the following information:

	Topic	See Page
3.1	Overview	23
3.2	Mounting Considerations and Overall Dimensions	25
3.3	Mounting Methods	26
3.4	Wiring Prerequisites	30
3.5	Input Wiring Procedures	32
3.6	Output Wiring Procedures	38

Pre-installation information

If the recorder has not been removed from its shipping carton, inspect the carton for damage and remove the recorder. Inspect the unit for any obvious shipping damage and report any damage due to transit to the carrier.

- Make sure a bag containing mounting hardware is included in the carton with the recorder.
- Check that the model number shown on the chart plate agrees with what you have ordered.

CE Conformity special conditions (Europe)

Shielded twisted pair cables are required for all Analog I/O, Process Variable, RTD, Thermocouple, dc millivolt, low level signal, 4-20 mA, and relay output circuits. Supplementary bonding of the recorder enclosure to a local ground, using a No. 11 (4mm²) braided copper conductor, is required. Ferrite suppression filters (see Subsection 3.4 for Wiring Prerequisites) shall be installed on all cables connected to the recorder/controller.

Refer to Appendix B - Severe Electrical Noise Environments for additional installation guidance.

Continued on next page

3.1 Overview, Continued

Operating limits

We recommend that you review and adhere to the operating limits listed in Table 3-1 when you install your recorder.

Table 3-1 Operating Limits and Condensed Specifications

Condition	Specifications
Accuracy	Refer to Appendix C
Ambient Temperature	32 to 131°F (0 to 55°C)
Relative Humidity	5 to 90% RH at 40°C (104°F)
Vibration Frequency Acceleration	0 to 200Hz 0.5g
Mechanical Shock Acceleration Duration	5g 30ms
Mounting Position from Vertical Tilted Forward Tilted Backward Tilted to side(±)	5° 90° 20°
Power Voltage(VRMS) Frequency(Hz)	102 to 132 Vac 204 to 264 Vac 49 to 51 Hz 59 to 61 Hz
Power Consumption	17 Watts Maximum
Types of Input Actuators	<i>Thermocouple:</i> T, T(low), W5W26% <i>RTD Platinum:</i> 100 Ohms*, 100 Ohms (low), 100 Ohms (T)** <i>Linear:</i> 4–20mAdc, 0–20mAdc, 0–10mVdc, 0–100mVdc, 0–1Vdc, 0–5Vdc, 1–5Vdc, 0–10Vdc * IEC Alpha = 0.00385 ** IEC Alpha = 0.00391
Minimum Input Span	Range is fully configurable within span limitation of the sensing element.
Span Step Response Time	7 seconds maximum
Reproducibility	0.1 percent of span
Sampling Rate	Input sampled 2 times every 1.3 seconds
Input Filter	<i>Software:</i> Single pole lowpass section with selectable time constants up to 120 seconds
Digital Displays	Vacuum fluorescent, alphanumeric A four digit display dedicated to the process variable. Alternate information displayed during configuration. A six digit display shows key selected operating parameters. Also provides guidance during configuration.

Continued on next page

3.1 Overview, Continued

Operating limits, continued

Table 3-1 Operating Limits and Condensed Specifications, continued

Condition	Specifications
Controller Modes of Operation	Manual Automatic with local set point
Indicators	Channel PV display (INP 1 or 2) Controller output (OUT 1 or 2) Temperature unit (F or C) Controller's mode (A or M)
Controller Output	<p>On-Off or Time Proportional One SPST electromechanical relay. Control action can be set for direct or reverse; N.O. or N.C. contact selectable. <i>Relay Contact Ratings:</i> <i>Resistive Load:</i> 5A @ 120 Vac, 2.5A @ 240 Vac <i>Inductive Load:</i> 50 VA @ 120 Vac or 240 Vac <i>Time Proportional Relay Resolution:</i> 4.4mSec. <i>Cycle Time:</i> 1 to 120 seconds</p> <p>Current Proportional 21 mA dc maximum into a negative or positive grounded or non-grounded load of 0 to 600 ohms. Output range can be set between 4 and 20 mA, and as direct or reverse action. <i>Resolution:</i> 10 bits <i>Accuracy:</i> 0.5% Full Scale</p> <p>Time Proportional Duplex Variation of time proportional for Heat/Cool applications. Uses two relay contacts with adjustable deadband that is split at 50% controller output.</p>
Case	Molded, foamed-Noryl* with gasketed door to meet NEMA 3 enclosure requirements.
Pen	Disposable fiber-tip ink cartridge, line length per cartridge more than 1000ft (305m) <i>One Pen:</i> Purple <i>Two Pen:</i> Purple (pen one) and red (pen two)
Chart	10.34-inch (260mm) diameter chart with standard preprinted markings and a calibrated width of 4 inches (100mm).
Wiring Connections	Screw terminals inside case.
Color	<i>Case:</i> Black <i>Gray Door (standard):</i> Caribbean blue (optional)
Weight	12 lbs (5.4 kg)
Mounting	Panel or surface mounted

Continued on next page

3.1 Overview, Continued

Operating limits, continued

Table 3-1 Operating Limits and Condensed Specifications, continued

Options:	
Alarm Output	One SPST electromechanical relay for an alarm. <i>Relay contact ratings:</i> <i>Resistive Load: 5A @ 120 Vac or 2.5A @ 240 Vac</i> <i>Inductive Load: 50 VA @ 120 Vac or 240 Vac</i>
Transmitter Supply Voltage	24Vdc 40mA max.
Approval Bodies	UL, CSA
CE Conformity (Europe)	This product is in conformity with the protection requirements of the following European Council Directives: 73/23/EEC , the Low Voltage Directive, and 89/336/EEC , the EMC Directive. Conformity of this product with any other "CE Mark" Directive(s) shall not be assumed.
Product Classification	Class 1: Permanently connected, Panel/Surface Mounted Industrial Control Equipment with protective earthing (grounding). (EN 61010-1)
Enclosure Rating	Panel/Surface Mounted Equipment, IP 54. (ref. IEC 529)
Installation Category (Overvoltage Category)	Category II: Energy-consuming equipment supplied from the fixed installation. Local level appliances, and Industrial Control Equipment. (EN 61010-1)
Pollution Degree	Pollution Degree 2: Normally non-conductive pollution with occasional conductivity caused by condensation. (ref. IEC 664-1)
EMC Classification	Group 1, Class A, ISM Equipment (EN 55011, emissions), Industrial Equipment (EN50082-2, immunity)
Method of EMC Assessment	Technical File (TF)

www.DataSheet4U.com

3.2 Mounting Considerations and Overall Dimensions

Physical considerations The recorder can be mounted flush in a panel or on the surface of a panel or wall using the mounting kit supplied with the recorder. Adequate access space must be available at the back of the panel for installation and servicing activities.

The overall dimensions and panel cutout requirements for mounting the recorder are shown in Figure 3-1.

Overall dimensions Figure 3-1 shows the overall dimensions for mounting the recorder.

Figure 3-1 Overall Dimensions

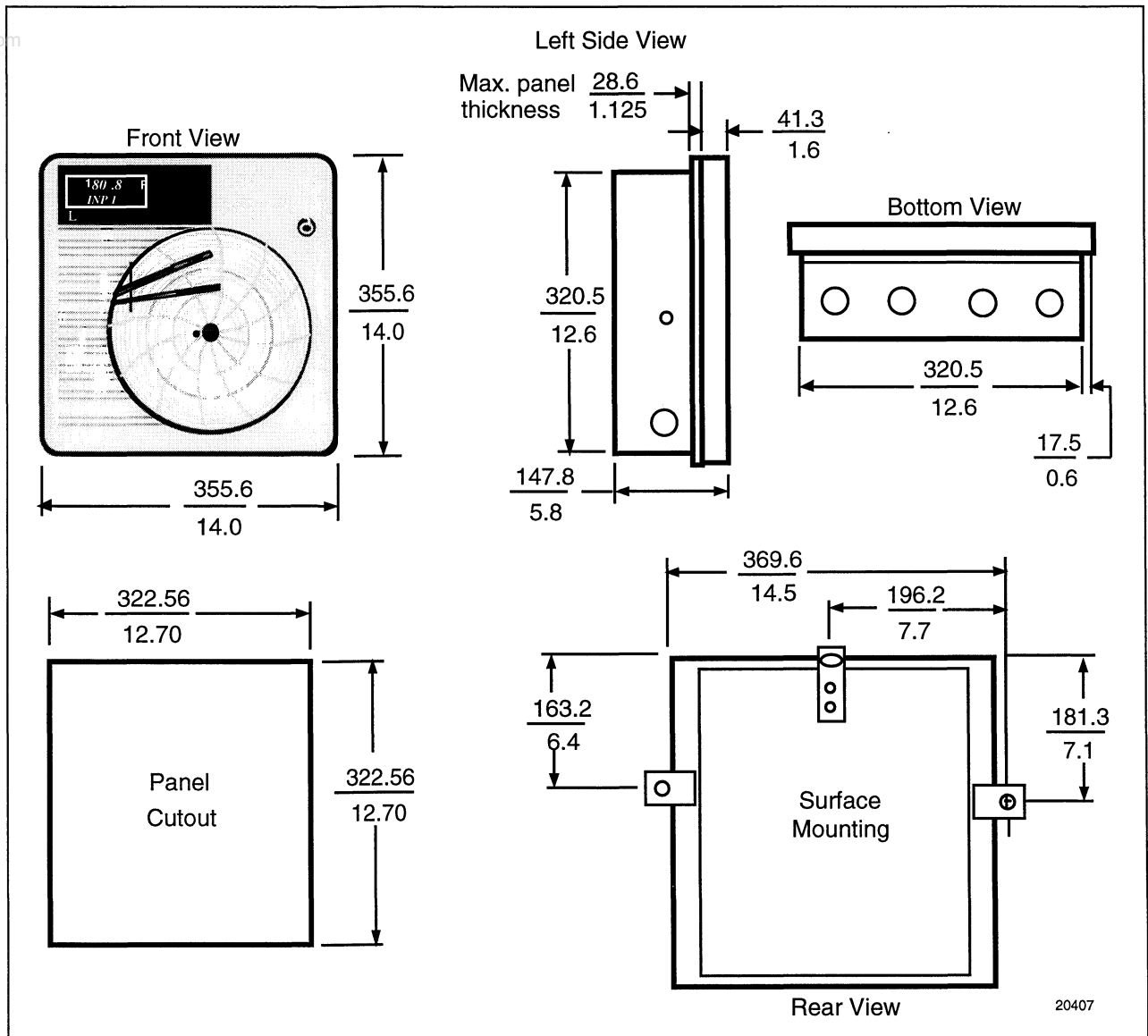

Continued on next page

3.3 Mounting Methods

Introduction

There are two methods available for mounting your recorder. They are:

- Flush in Panel (New Panel Cutout)
- On Surface (of Panel or Wall)

Procedures for each method follow. Choose the one that meets your mounting requirements. Use the associated dimension drawings for reference.

How to remove knockouts for conduits

Before you mount the recorder, remove the appropriate “knockouts” in the bottom and/or sides of the recorder case for wire entry via 1/2" (12.7mm) conduits. Refer to figure 3-2 for knockout locations.

ATTENTION The knockouts are really plugs that you just have to push out to remove.

Figure 3-2 How to Remove Knockouts

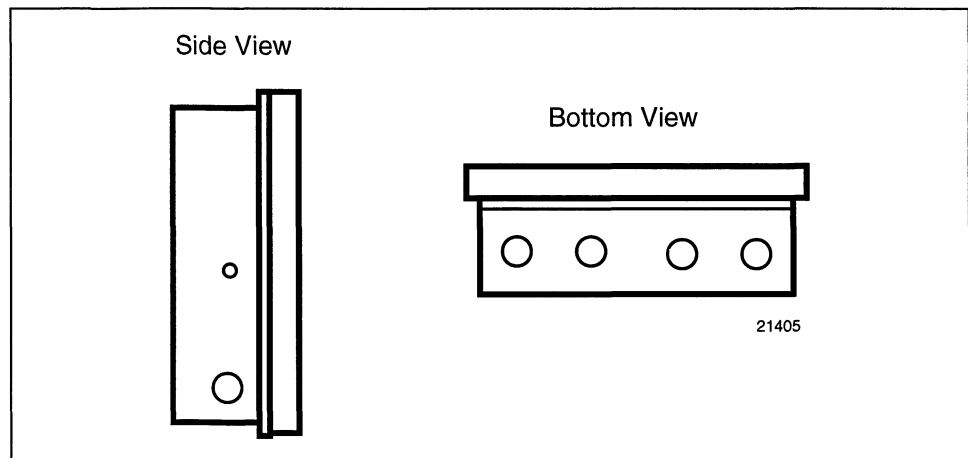

Continued on next page

3.3 Mounting Methods, Continued

Mounting flush in panel (New panel cutout) Refer to Figure 3-3 and follow the procedure in Table 32 to make a new cutout in a panel and mount your recorder in the cutout.

Table 3-2 Mounting Flush in a New Panel Cutout

Step	Action
1	At the appropriate location, make a square cutout in the panel measuring 12.7 ± 0.060 inches by 12.7 ± 0.060 inches (322.58 ± 1.52 by 322.58 ± 1.52 millimeters). See Figure 3-3.
2	Orient the recorder case properly and slide it into the cutout from the front of the panel. Support the recorder as shown in steps 3 and 4.
3	Refer to Figure 3-3. From the back of the panel, attach a mounting bracket to each side of the recorder case using a 1/4-20 x 1/2 inch hex screw for each bracket (mounting hardware supplied with recorder). Leave the screws slightly loose so you can adjust the brackets.
4	While holding the recorder firmly against the panel, slide each bracket against the back of the panel and tighten the screws.

Figure 3-3 Mounting Flush in a New Panel Cutout

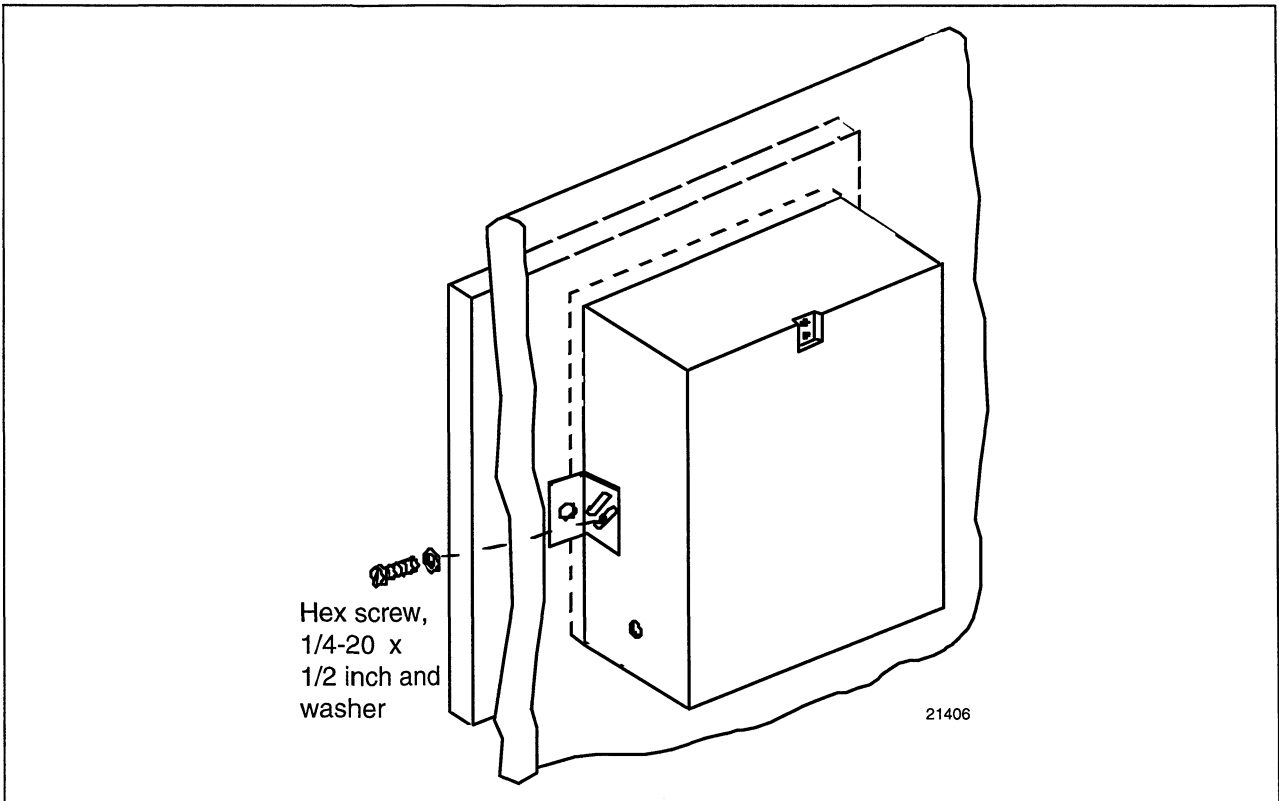

Continued on next page

3.3 Mounting Methods, Continued

Mounting on surface (of panel or wall)

Refer to Figure 3-4 and follow the procedure in Table 3-3 to mount your recorder on a surface (Panel or Wall).

ATTENTION Three (3) screws must be supplied by the user for attaching the mounting hardware (brackets and support hook) to panel or wall.

Table 3-3 Mounting Flush on a Surface (of Panel or Wall)

Step	Action
1	Using two flat-head 10-32 x 1/4-inch screws supplied with the recorder, fasten the support hook into the recess at the back of the recorder case as shown in Figure 3-4.
2	Using 1/4-20 x 1/2-inch hex screws and lockwashers, attach a mounting bracket to each side of the case. Leave the screws slightly loose so as to permit some adjustments of the brackets.
3	On the panel, mark the locations for the three holes, as shown by the hole pattern in Figure 3-4.
4	Using a drill of appropriate size for user-supplied screws, drill a hole in the front of the panel for the eye of the support hook.
5	Insert the screws for the support hook into the panel, allowing the screw head to protrude approximately 5/16 inch.
6	Hang the recorder support hook on the screw. Make sure that the locations for the other two holes (marked in step three) are correct. If not, make sure that the recorder is aligned vertically, and use the brackets as templates to mark the proper locations.
7	Remove the recorder from the panel and drill the other two holes.
8	Hang the recorder on the screw by the support hook and insert the other two user-supplied screws through the brackets into the panel. Tighten the two hex screws that attach the brackets to the case.

Continued on next page

3.3 Mounting Methods, Continued

Mounting on surface (of panel or wall), continued

Figure 3-4 Mounting Flush on a Surface (of Panel or Wall)

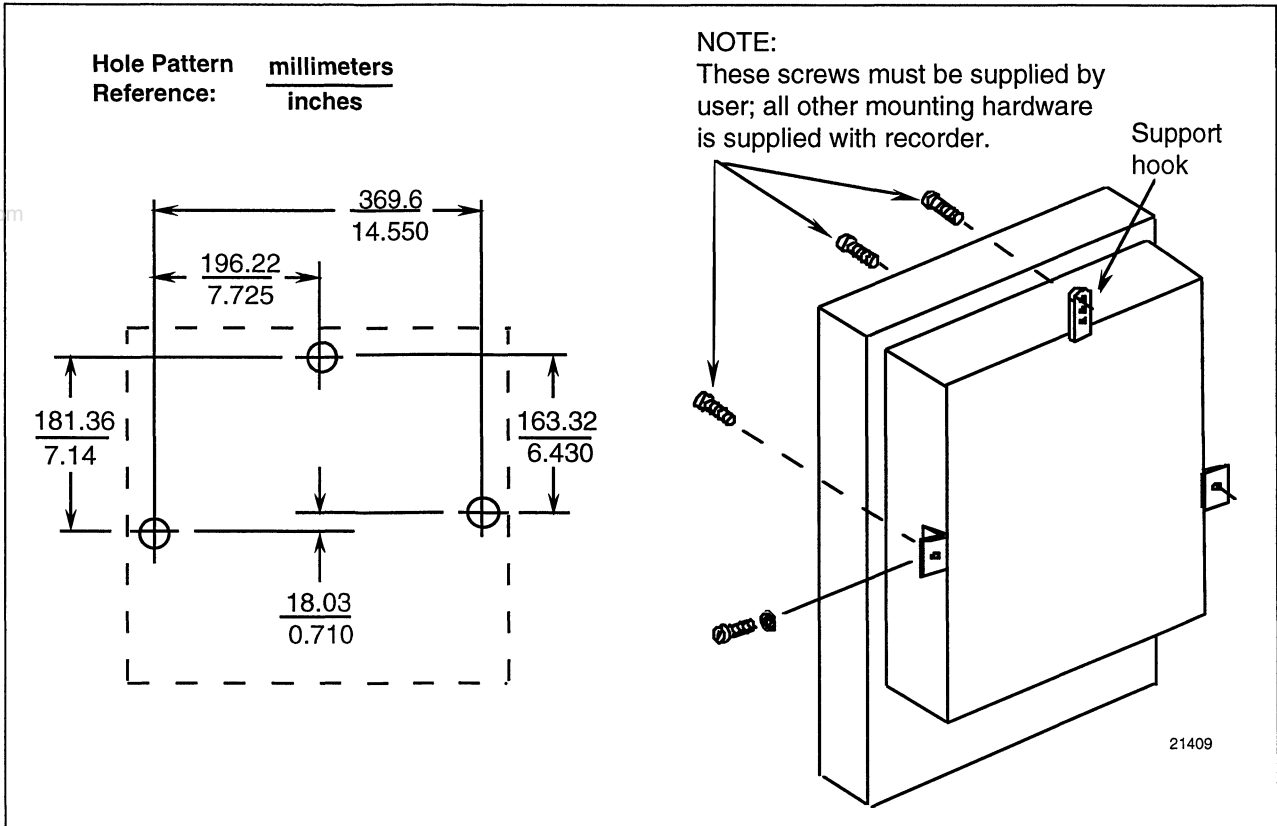

3.4 Wiring Prerequisites

Taking electrical noise precautions

Electrical noise is composed of unabated electrical signals which produce undesirable effects in measurements and control circuits.

Digital equipment is especially sensitive to the effects of electrical noise. Your recorder has built-in circuits to reduce the effect of electrical noise from various sources. If there is a need to further reduce these effects:

- **Separate External Wiring** - separate connecting wires into bundles (see Table 3-4) and route the individual bundles through separate conduits or metal trays.
- **Use Suppression Devices** - for additional noise protection, you may want to add suppression devices at the external source. Appropriate suppression devices are commercially available.

NOTE

For additional noise information, refer to *Appendix B*.

Electrical considerations



The recorder is considered “rack and panel mounted equipment” per EN 61010-1, Safety Requirements for Electrical Equipment for Measurement, Control, and Laboratory Use, Part 1: General Requirements.

Recorder grounding



PROTECTIVE BONDING (grounding) of this recorder shall be in accordance with National and local electrical codes. To minimize electrical noise and transients that may adversely affect the system, supplementary bonding of the recorder enclosure to a local ground, using a No. 11 (4 mm²) braided copper conductor, is required.

CE Conformity Special Conditions (Europe)

Shielded cables with a drain wire are required for all Input I/O and Output Relay cables. All instrument shielded cable drain wires must be connected to a low impedance earth ground at the entry fitting. Cable/conduit entry fittings shall effectively terminate the cable shield connecting the shield to the enclosure conductive coating. The shielded cable shield shall not extend into the instrument closure.

Inside of the enclosure, the user must install ferrite suppression filters on all wires connected to the recorder. ©Fair-Rite Products Corp. part number 0443164151, or equivalent, shall be installed as shown in Figures 3-5 to 3-10, one filter for each circuit group. Cable with an outer jacket diameter larger than 6.7 mm (0.264 in.) may require the outer jacket to be removed to fit the required one turn in the filter, or the selection of a different cable.

Continued on next page

3.4 Wiring Prerequisites, Continued

Permissible wire bundling

Table 3-4 shows which wire functions should be bundled together.

Table 3-4 Permissible Wiring Bundling

Bundle No.	Wire Functions
1	<ul style="list-style-type: none"> • Line power wiring • Control relay output wiring • Line voltage alarm wiring
2	Analog signal wire, such as: <ul style="list-style-type: none"> • Input signal wire (thermocouple, 4 to 20 mA, etc.) • 4-20mA output signal wiring
3	<ul style="list-style-type: none"> • Low voltage alarm relay output wiring • Low voltage wiring to solid state type control circuits

Identify your wiring requirements

To determine the appropriate diagrams for wiring your recorder, refer to the model number interpretation in *Section 1 - Overview*. The model number of the recorder can be found on the chart plate.

Wiring the recorder

Using the information contained in the model number, select the appropriate wiring diagrams from the figures listed below and wire the recorder accordingly.

Wiring Requirements	Figure
Ferrite Filter Locations (CE Mark)	3-5
AC Line Power	3-6
Input 1	3-7
Input 2	3-8
Power Supply Output	3-9
Control Output (1 or 2 pen)	3-10

3.4 Wiring Prerequisites, Continued

Ferrite filter locations (CE Mark)

Inside of the enclosure, install ferrite suppression filters on all wires connected to the recorder. ©Fair-Rite Products Corp. part number 0443164151, or equivalent, shall be installed as shown in Figures 3-5, one filter for each circuit group. Cable with an outer jacket diameter larger than 6.7 mm (0.264 in.) may require the outer jacket to be removed to fit the required one turn in the filter, or the selection of a different cable.

Figure 3-5 Ferrite Filter Locations (CE Mark)

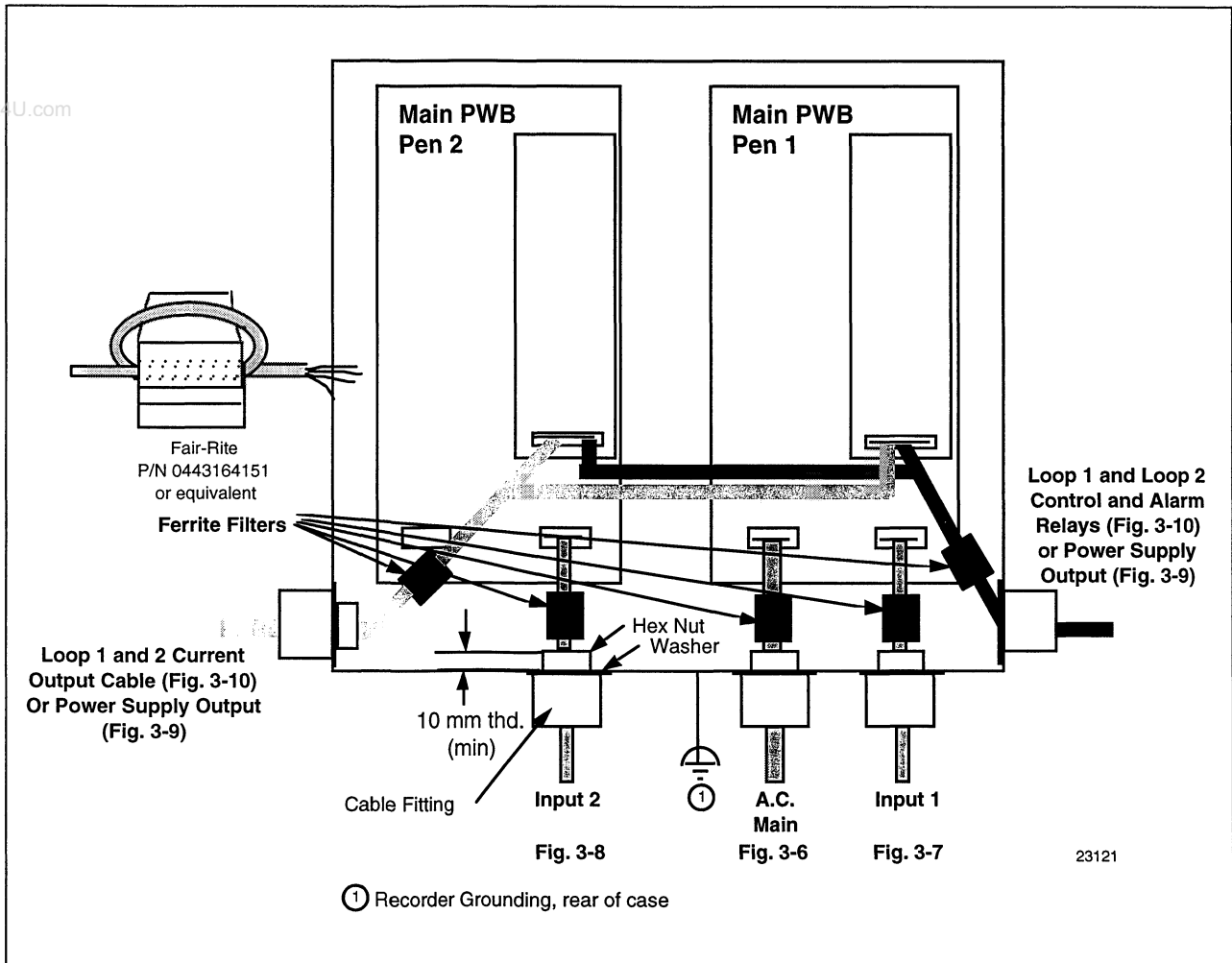

3.5 Input Wiring Procedures

AC Line Power



Refer to Figure 3-6 and follow the procedure in Table 3-5 to connect the AC line power.

WARNING Be sure that the line voltage is OFF before connecting the power wires to the recorder.

This equipment is suitable for connection to 120/240 Vac, 50/60 Hz, power supply mains. It is the user's responsibility to provide a switch and non-time delay (North America), quick-acting, high breaking capacity, Type F, (Europe) 1/2 A, 250 V fuse(s) or circuit-breaker as part of the installation. The switch or circuit-breaker shall be located in close proximity to the recorder, within easy reach of the OPERATOR. The switch or circuit-breaker shall be marked as the disconnecting device for the recorder.

Table 3-5 AC Line Power Wiring

Step	Action
1	Open the recorder door. Loosen the captive screw in the chart plate and swing the plate out.
2	Locate terminal block TB1 on the bottom left edge of the Main printed circuit board for pen 1 (refer to Figure 3-6).
3	Run the power wires separately through second conduit from the right on the bottom of the case.
4	For CE Mark conformity, install the ferrite filter as shown in figure 3-5.
5	Strip insulation from the end of each wire and form end to fit under a screw connection or insert into connector.
<p>CAUTION To avoid damaging the recorder, be sure that you install the power wires into the correct screw terminals.</p> <p>Be sure you have positioned Jumper W1 (See Section 2 - Set Up) to match the given supply voltage rating - 120 or 240 Volts for both pen 1 and pen 2 Main printed circuit boards. The factory setting is 120 Volts.</p>	
6	<p>Insert the <i>green</i> wire (G) under the first screw from the right, the <i>white</i> wire (N/L2) under the second screw from the right, and the <i>black</i> wire (L/L1) under the third screw from the right. Tighten the screws to secure the wires.</p> <p>ATTENTION On recorders with two pens, an internal cable channels power to TB1 on the main printed circuit board for pen 2 from TB1 on the main printed circuit board for pen 1.</p>
7	<p>Dress the wires as slack as possible. This keeps the noise signal on these wires from bypassing built-in suppression. Also, do not bundle any low level signal wires with the power wires. Refer to Table 3-4 for permissible wire bundling.</p> <p>Refer to Appendix B for additional information concerning noise interference prevention.</p>
<p>WARNING Input line voltage will be present on the instrument ground plane if safety ground is not attached</p>	

Continued on next page

3.5 Input Wiring Procedures, Continued

AC line power, continued

Figure 3-6 AC Line Power Wiring

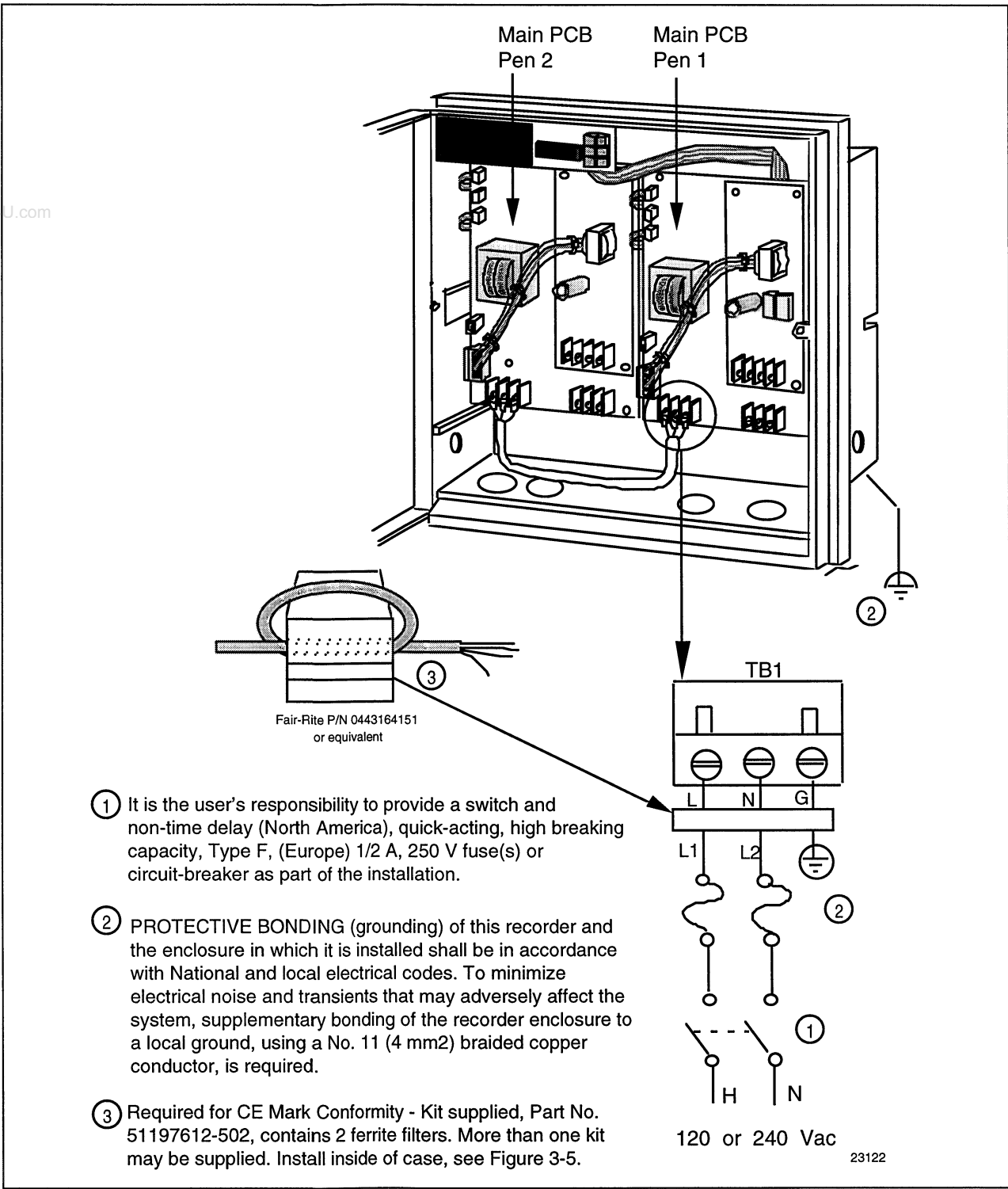

Continued on next page

3.5 Input Wiring Procedures, Continued

Input 1

You can wire Input 1 for Thermocouple, RTD, mA, mV, or Volt actuations. Refer to Figure 3-7 and follow the procedure in Table 3-6 to wire the input.

ATTENTION Make sure you have configured the recorder to accept the desired input type. Refer to *Section 2 - Recorder Set Up Tasks*.

Table 3-6 Input 1 Wiring

Step	Action
1	Open the recorder door. Loosen the captive screw in the chart plate and swing the plate out.
2	Locate terminal block TB3 on the bottom right edge of the Main printed circuit board for pen 1 (refer to Figure 3-7).
3	Run the input wires through the desired conduit - DO NOT bundle them with the power wires.
4	For CE Mark conformity, install the ferrite filter as shown in figure 3-5.
5	Strip insulation from the end of each wire and form end to fit under a screw connection or insert into connector.
6	Insert the wires under the appropriate screws for the applicable input type. See Figure 3-7 for specific input actuation wiring. Tighten the screws to secure the wires.

Continued on next page

3.5 Input Wiring Procedures, Continued

Input 1, continued

Figure 3-7 Input 1 Wiring

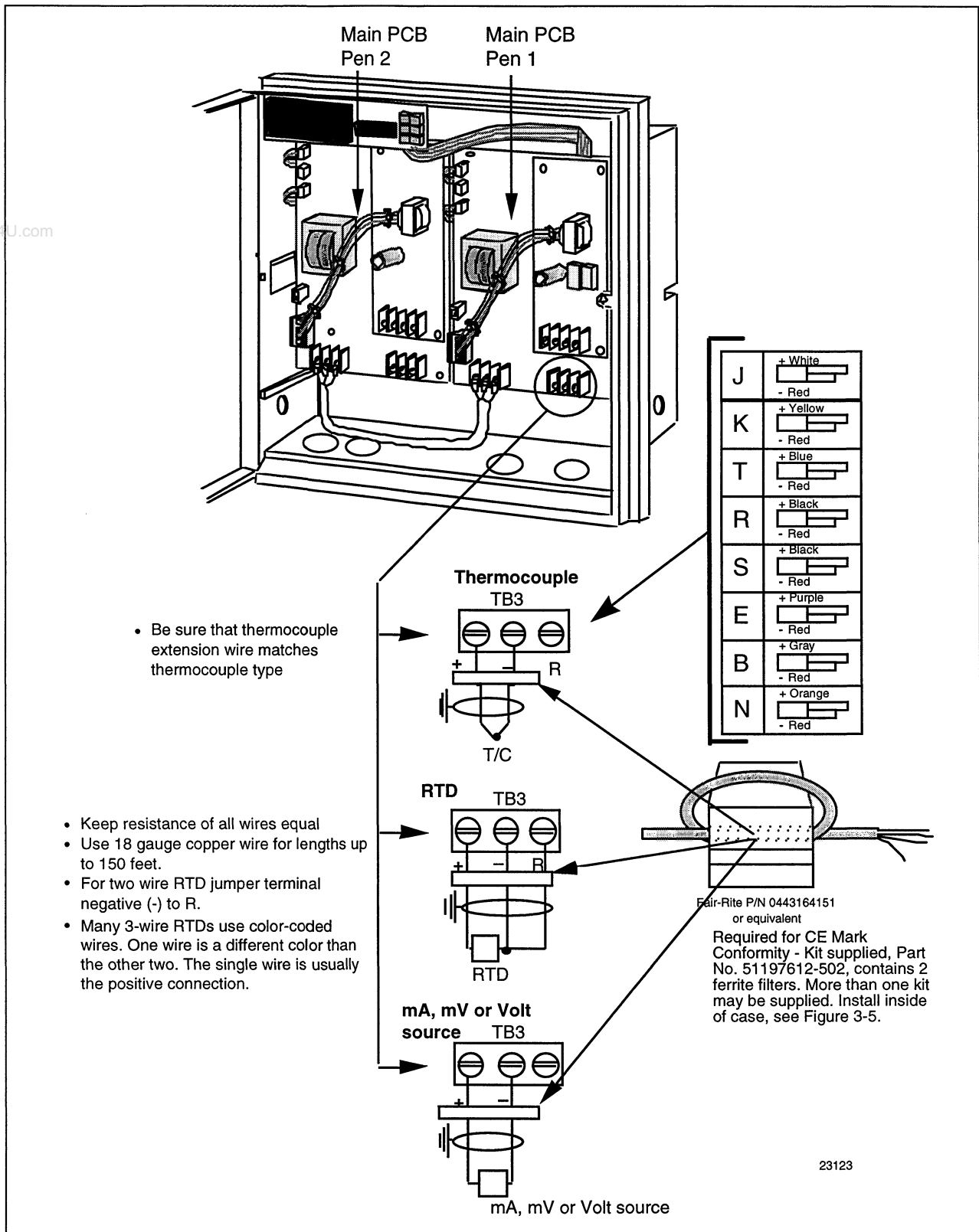

Continued on next page

3.5 Input Wiring Procedures, Continued

Input 2

You can wire Input 2 for Thermocouple, RTD, mA, mV, or Volt actuations. Refer to Figure 3-8 and follow the procedure in Table 3-7 to wire the input.

ATTENTION Make sure you have configured the recorder to accept the desired input type (refer to *Section 2 - Recorder Set Up Tasks*).

Table 3-7 Input 2 Wiring

Step	Action
1	Open the recorder door. Loosen the captive screw in the chart plate and swing the plate out.
2	Locate terminal block TB3 on the bottom right edge of the main printed circuit board for pen 2 (refer to Figure 3-8).
3	Run the input wires through the desired conduit - DO NOT bundle them with the power wires.
4	For CE Mark conformity, install the ferrite filter as shown in figure 3-5.
5	Strip insulation from the end of each wire and form end to fit under a screw connection or insert into connector.
6	Insert the wires under the appropriate screws for the applicable input type. See Figure 3-7 for specific input actuation wiring. Tighten the screws to secure the wires.

Continued on next page

3.5 Input Wiring Procedures, Continued

Input 2, continued

Figure 3-8 Input 2 Wiring

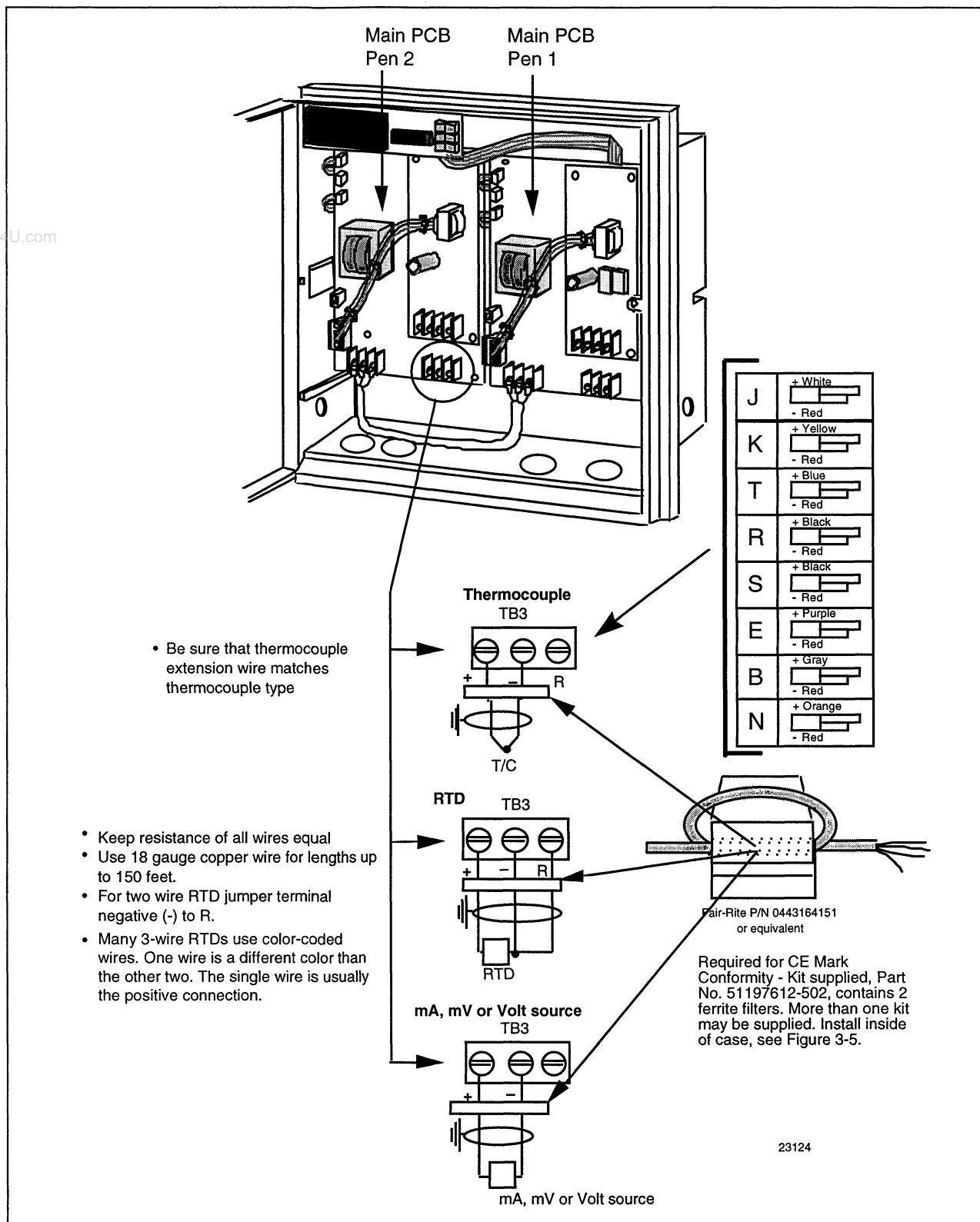

Continued on next page

3.6 Output Wiring Procedures

Power supply output wiring

You can wire the Power Supply Output for 24 volt power supply (Model Number Table I = 3X or X3).

Refer to Figure 3-9 and follow the procedure in Table 3-8 to wire the Power Supply Output.

Table 3-8 Power Supply Output Wiring

Step	Action
1	Open the recorder door. Loosen the captive screw in the chart plate and swing the plate out.
2	Locate terminal block TB1 on the bottom edge of the power supply printed circuit board for pen 1 or pen 2 (refer to Figure 3-9).
3	Run the output wires through the desired conduit - DO NOT bundle them with input wires.
4	For CE Mark conformity, install the ferrite filter as shown in Figure 3-5.
5	Strip insulation from the end of each wire and form end to fit under a screw connection or insert into connector.
6	Insert the wires under the appropriate screws for the voltage output as shown (refer to Figure 3-9). Tighten the screws to secure the wires.
7	Repeat steps 2-5 if the power supply printed circuit board is provided on the other Main printed circuit board.

Continued on next page

3.6 Output Wiring Procedures, Continued

Power supply output wiring, continued

Figure 3-9 shows you the recorder output connections for power supply printed circuit boards for recorders with Model Table I = 3X or X3 (24 volt power supply).

A single power supply option board is capable of driving two transmitters.

Figure 3-9 Recorder Output Connections for 24V Power Supply

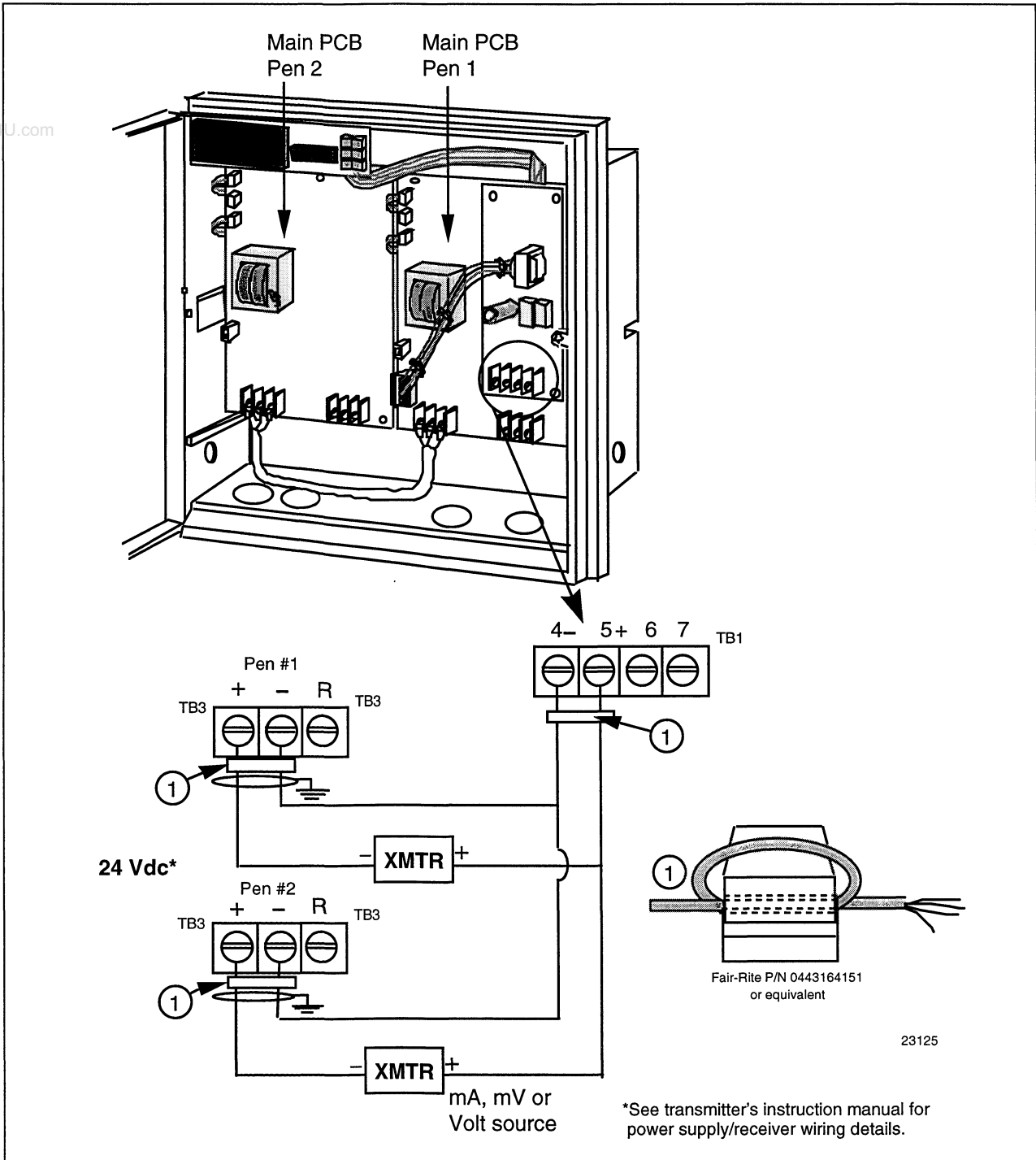

3.6 Output Wiring Procedures, Continued

Control output wiring, (1 or 2 Pen Models)

You can wire the Control Output for 1 or 2 pen models (Model Table I = 1X, X1, 2X, or X2).

ATTENTION

Make sure you have configured the recorder to provide the desired control/alarm function and action, as applicable.

Refer to *Section 2 - Recorder Set Up Tasks*.

For Model Table I = 1X or X1, be sure the recorder is configured to provide current (4-20 mA) or relay 1 output as applicable.

Refer to Figure 3-10 and follow the procedure in Table 3-9 to wire the Relay Outputs.

CAUTION

For control printed circuit board for Model Table I = 1X or X1, be sure jumpers W5 and W6 are installed and jumper W1/W2 for relay 1 is removed for current output control application. Or, jumper W1/W2 for relay 1 is installed and jumpers W5 and W6 are removed for relay 1 output for control or alarm application.

Table 3-9 Relay Output Wiring – 1 or 2 Pen Models

Step	Action
1	Open the recorder door. Loosen the captive screw in the chart plate and swing the plate out.
2	Locate terminal block TB1 on the bottom edge of the Control printed circuit board on the Main printed circuit board for pen 1 or pen 2 (refer to Figure 3-9 for location).
3	Run the output wires through the desired knockout. DO NOT bundle them with Input wires.
4	Strip insulation from the end of each wire and form end to fit under a screw connection or insert into connector.
5	Insert the wires under the appropriate screws for the applicable relay, or current output as shown (refer to Figure 3-10). Tighten the screws to secure the wires.
6	Repeat steps 2 to 5 for Control printed circuit board mounted on the other Main printed circuit board, as applicable.

Continued on next page

3.6 Output Wiring Procedures, Continued

Control output wiring, (1 or 2 Pen Models)

Figure 3-10 Control Output Wiring – 1 or 2 Pen Models

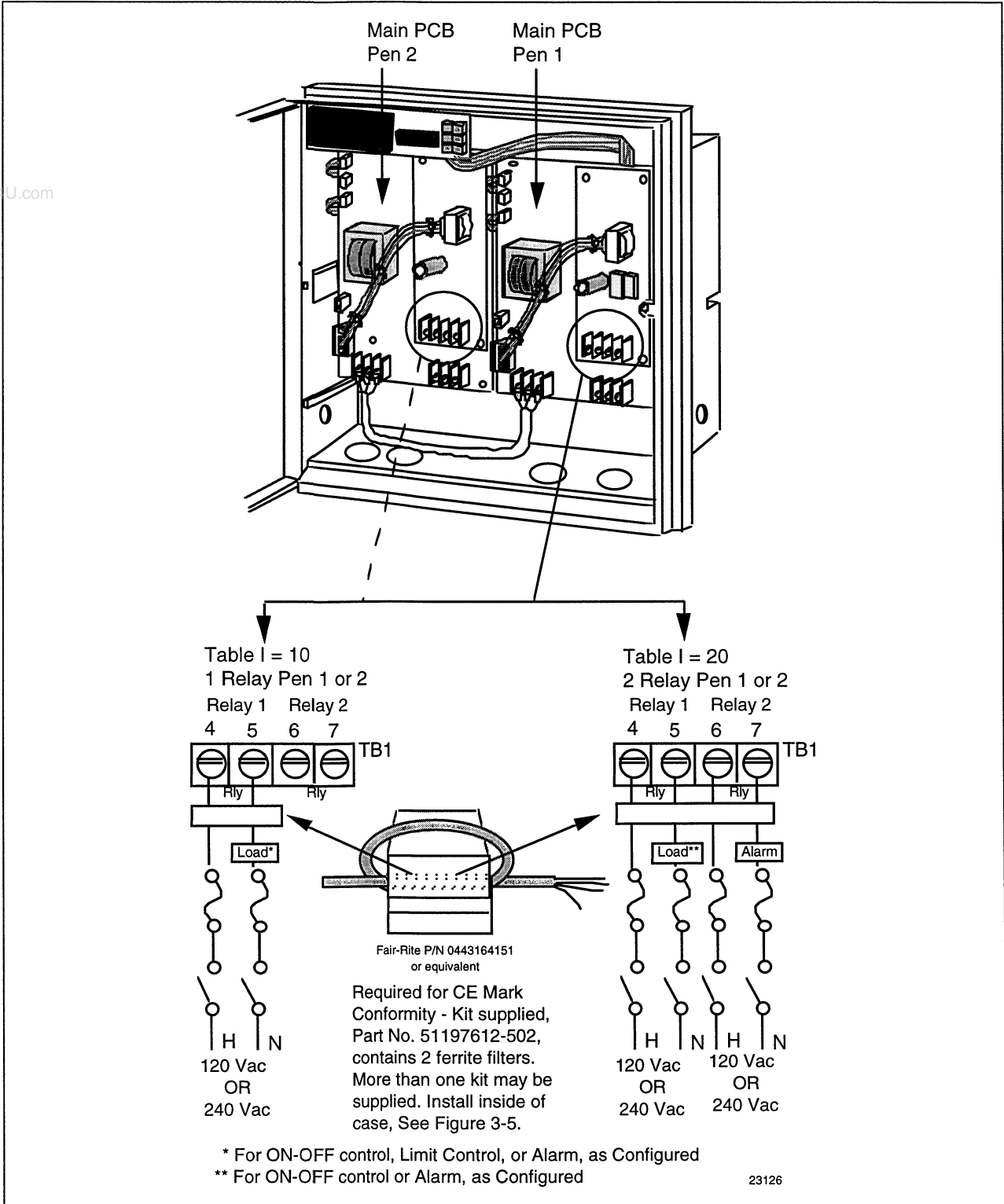

Section 4 – Configuration

4.1 Overview

Introduction

Configuration is a dedicated operation where you use straightforward keystroke sequences to select and establish (configure) pertinent control data best suited for your application.

What's in this section? The table below lists the topics that are covered in this section.

	Topic	See Page
4.1	Overview	45
4.2	Configuration Prompts	46
4.3	How to Get Started	47
4.4	Configuration Tips	48
4.5	Configuration Procedure	49
4.6	Chart Set Up Group	51
4.7	Pen Set Up Group	52
4.8	Input Set Up Group	53
4.9	Totalizer Set Up Group	57
4.10	Output Setup Group	59
4.11	Control Set Up Group	60
4.12	Tuning Parameters Set Up Group	64
4.13	Cycle Set Up Group	66
4.14	Alarms Set Up Group	67
4.15	Lockout Set Up Group	70
4.16	Configuration Record Sheet	71

Prompts

To assist you in the configuration process, there are prompts that appear in the upper and lower displays. These prompts let you know what group of configuration data (set up prompts) you are working with and also the specific parameters (function prompts) associated with each group.

Figure 4-1 shows an overview of the prompt hierarchy. As you will see, the configuration data is divided into 10 main set up groups.

Continued on next page

4.2 Configuration Prompts

Diagram: prompt hierarchy

Figure 4-1 shows an overview of the DR4200 EV Set Up prompts and their associated Function prompt - read from left to right.

Figure 4-1 DR4200 EV Prompt Hierarchy

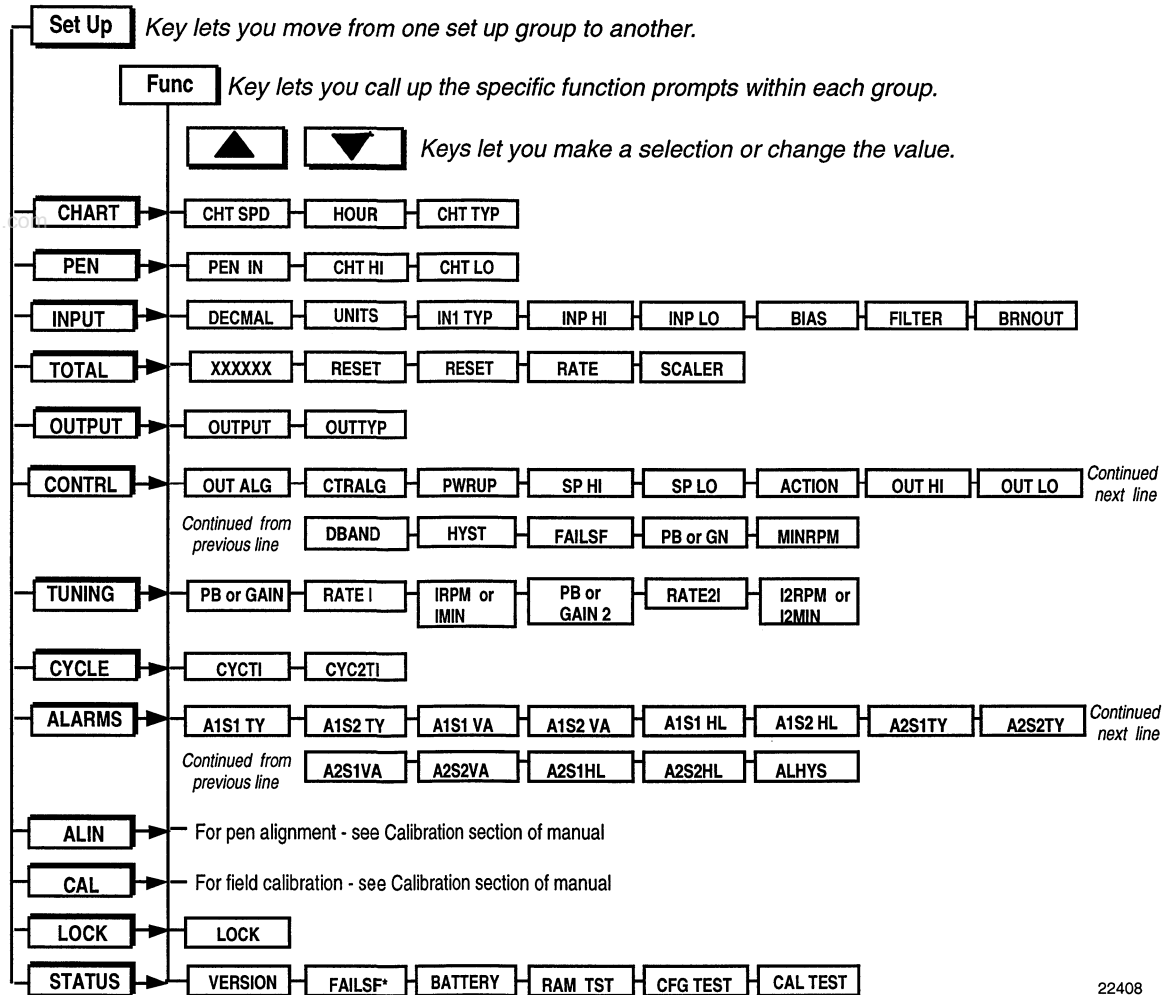

4.3 How To Get Started

Read the configuration tips	Read subsection 4.4 “ <i>Configuration Tips</i> ” which will help you to easily and quickly configure your recorder.
Read configuration procedure	Read subsection 4.5 “ <i>Configuration Procedure</i> ” which tells you how to access the Set Up groups, and the function parameters within each of these groups that are shown in the Prompt Hierarchy in Figure 4-1.
Set Up groups	The Set Up groups and function parameters are listed in the order of their appearance. The list includes the name of the prompt, the range of setting or selections available, and the factory setting. It allows you to quickly find a parameter and obtain the available range or selection you require.
Parameter explanations or definitions	This section lists the set up and function prompts, the selections or range of settings that you can make for each, plus a detailed explanation or definition of each parameter .
Configuration record sheet	Located in subsection 4.16 is a “ <i>Configuration Record Sheet</i> ”. When you make your configuration selections, record them on this sheet. Then you will have a record of how the recorder was configured.

4.4 Configuration Tips

Introduction

Listed below in Table 4-1 are a few tips that will help you enter the configuration data more quickly.

Table 4-1 Configuration Tips

Function	Tip
Displaying Groups	Use the SET UP key to display the Set Up groups. The group titles are listed in this section in the order that they appear in the recorder.
Displaying Functions	Use the FUNC key to display the individual parameters under each group. The prompts are listed in the order of their appearance in each group.
Scrolling	To get to a Set Up group prompt more quickly, hold the SET UP key in. To get to a function prompt more quickly, hold the FUNC key in. The display will scroll through the parameters.
Changing values quickly	When Changing the value of a parameter, you can adjust a more significant digit in the upper display by holding in one key [▲] or [▼], and pressing the other [▲] or [▼] at the same time. <ul style="list-style-type: none"> • The adjustment will move one digit to the left. • Press the key again and you will move one more digit to the left.
Exiting SET UP mode	To exit Set Up mode, press the DISP key. This returns the display to the same state it was in immediately preceding entry into the Set Up mode.
Timing out from Set Up mode	If you are in Set Up mode and do not press any keys for one minute, the recorder will time out and revert to the mode and display that was being used prior to entry into Set Up mode.

4.5 Configuration Procedure

Introduction

The configuration prompts are sequenced in a group/function hierarchical set as shown in Figure 4-1. Make sure that you configure all the parameters that are applicable for your given recorder model and application requirement as well as match the hardware configuration selections (see *Section 2 - Setup Tasks*).

To enter your selections or values, follow the procedure in Table 4-2 and fill in the values or selections on the worksheet in subsection 4.16 for the applicable function parameters. Keep this worksheet as a record of how your recorder was configured.

This procedure tells you the keys to press to get to any Set Up group (and any associated function parameters prompt).

www.DataSheet4U.com

Procedure

Follow the procedure listed in Table 4-2 to access the Set Up groups and Function prompts. If you have a two-pen recorder, be sure to identify individual parameters for each pen and control loop as applicable.

Make sure Set Up group "Lock" is set to "NONE" or "CAL." See subsection 4.15.

Table 4-2 Configuration Procedure















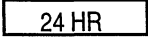
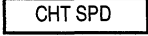

Step	Operation	Press	Result
1	Select Set Up mode		<p>Upper Display  Lets you know you are in the configuration mode and a Set Up group title is being displayed in the lower display.</p> <p>Lower Display  This is the first Set Up group title.</p>
2	Select any Set Up group		<ul style="list-style-type: none"> • Successive presses of the  key will sequentially display the other Set Up group titles shown in the prompt hierarchy in Figure 4-1. • You can also use the [▲] [▼] keys to scan the Set Up groups in both directions. • Stop at the Set Up group title which describes the group of parameters you want to configure. Then proceed to the next step.

Table 4-2 is continued on next page

4.5 Configuration Procedure, Continued

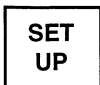
Procedure, continued

Table 4-2 Configuration Procedure, continued

Step	Operation	Press	Result
3	Select a Function Parameter		<p>Upper Display  Shows the current value or selection for the first function prompt of the particular Set Up group that you have selected.</p> <p>Lower Display  Depending on what is selected in Set Up group control. Shows the first function prompt within that Set Up group. Example displays show Set Up group "Chart", function prompt "CHT SPD" and the value selected.</p>
4	Select other Function Parameters		<ul style="list-style-type: none"> • Successive presses of the  key will sequentially display the other function prompts of the Set Up group you have selected. • Stop at the function prompt that you want to change, then proceed to the next step.
5	Change the value or selection	 or 	<ul style="list-style-type: none"> • These keys increment or decrement the value or selection that appears for the function prompt you have selected. • See subsection 4.4 "Configuration Tips" for instructions to increase or decrease value quickly. • Change the value or selection to meet your needs. • If the display flashes, you are trying to make an unacceptable entry.
6	Enter the value or selection	 or 	<ul style="list-style-type: none"> • This key selects another function prompt. • This key selects another Set Up group. <p>The value or selection you have made will be entered into memory after another key is pressed.</p>
7	Exit Configuration		This exits configuration mode and returns the recorder to the same state it was in immediately preceding entry into the Set Up mode. It stores any changes you have made.
8	2-Pen Recorders		For 2-pen recorders, press  key to select INP2 for display and go to step 1 to configure the parameters for pen 2.

4.6 Chart Parameters Set Up Group

Introduction

The functions listed in this group deal with the parameters that have to be set for the proper chart function. For a 2-pen recorder the desired input channel is displayed on the left side of the operator interface. Press **FUNC** key to select channel.

Chart group prompts

Table 4-3 lists all the function prompts in the “Chart” parameters set up group. Press **SET UP** key until “CHART” appears in the lower display. Press **FUNC** key to display parameters.

Table 4-3 Chart Parameters Group

Lower Display Prompt	Upper Display Range of Setting or Selection	Parameter Definition
CHTSPD	8HR 24HR 7DAYS __ HR	CHART SPEED — This is the time it will take to drive the chart one complete revolution. ATTENTION This prompt only appears for pen 1 configuration of a 2-pen recorder. 8 Hour revolution 24 Hour revolution 7 Day revolution __ hour revolution - make Hours per Revolution selection at prompt “HOUR/REV”.
HOUR/REV	1 to 744 Hours	HOURS PER REVOLUTION — Set the desired chart speed. Appears only if __ HR was selected at prompt “CHT SPD”.
CHTTYP	LIN NLIN	CHART TYPE - Selection is based on the type of chart Linear (even) or Non-Linear (i.e. J T/C or RTD) ATTENTION LIN chart type is automatically selected when configured input type is linear.

4.7 Pen Parameters Set Up Group

Introduction

The functions listed in this group deal with how to configure the pen(s). The procedure for configuring each pen is the same. For a 2-pen recorder, the desired input channel is displayed on the left side of the operator interface.

Press **FUNC** key to select channel. The prompts are shown in Table 4-4.

Pen group prompts

Table 4-4 lists all the function prompts in the Pen set up group.

Press the **SET UP** key until PEN appears in the lower display.

Press **FUNC** key to display parameters.

www.DataSheet4U.com

Table 4-4 Pen Parameters Group

Lower Display Prompt	Upper Display Range of Setting or Selection	Parameter Definition
PENIN	INP OUT* SP*	PEN INPUT — What do you want the pen to record? INPUT - records the Input for given channel OUTPUT - records Output for given channel SETPOINT - records Setpoint for given channel *Only selectable if Model Table I = 1X, 2X, or X2 and function prompt "OUTTYP" in Set Up group "OUTPUT" = "CTRL."
CHTHI	-999 to 9999	CHART HIGH RANGE VALUE — Enter a value that corresponds with the chart high range value for the pen.
CHTLO	-999 to 9999	CHART RANGE LOW VALUE — Enter a value that corresponds with the chart low range value for the pen.

4.8 Input Parameters Set Up Group

Introduction

These are the parameters required to configure the temperature units, decimal location, actuation, high and low range values in engineering units, bias, filter, and burnout. For a 2-pen recorder, the desired input channel is displayed on the left side of the operator interface.

Press **FUNC** key to select channel.

Input group prompts

Table 4-5 lists all the function prompts in the Input set up group.

Press **SETUP** key until "INPUT" appears in the lower display.

Press **FUNC** key to display the parameters.

www.DataSheet4U.com

Table 4-5 Input Parameters

Lower Display Prompt	Upper Display Range of Setting or Selection	Parameter Definition
DECMAL	XXXX XXX.X XX.XX	DECIMAL POINT LOCATION -- This selection determines where the decimal point appears in the display. None One Place Two Places NOTE: Be sure the selection agrees with the value to be displayed. If PV requires 4 whole digits, the decimal will not show. Function prompt "INTYP" must be linear to get 2 decimal place selection.
UNITS	NONE F C	TEMPERATURE UNITS -- This selection will be indicated on the PV display. No units Degrees Fahrenheit Degrees Celsius

Table 4-5 is continued on next page

4.8 Input Parameters Set Up Group, Continued

Table 4-5 Input Parameters Group, continued

Lower Display Prompt	Upper Display Range of Setting or Selection	Parameter Definition
IN TYPE		INPUT ACTUATION TYPE -- This selection determines what actuation you are going to use for the input. Be sure that the values configured for the high and low chart range, alarm setpoint, etc. are within the measuring range for the selected actuation type.
	B	B thermocouple 105 to 3300°F 41 to 1815°C
	EH	E thermocouple high -454 to 1832°F -270 to 1000°C
	EL	E thermocouple low -200 to 1100°F -129 to 593°C
	JH	J thermocouple high 0 to 1600°F -18 to 871°C
	JL	J thermocouple low 20 to 770°F -7 to 410°C
	KH	K thermocouple high -320 to 2500°F -196 to 1371°C
	KL	K thermocouple low -20 to 1000°F -29 to 538°C
	NNM	NNM NiNiMo thermocouple 32 to 2500°F 0 to 1371°C
	NIC	NIC Nicrosil-Nisil thermocouple 0 to 2372°F -18.8 to 1300°C
	R	R thermocouple 0 to 3100°F -18 to 1704°C
	S	S thermocouple 0 to 3100°F -18 to 1704°C
	TH	T thermocouple high -300 to 700°F -184 to 371°C
	TL	T thermocouple low -200 to 600°F -129 to 316°C
	W	W5W26 thermocouple high 0 to 4200°F -18 to 2316°C
	100 H**	100 Ohm-RTD (high) -300 to 900°F -184 to 482°C
	100 L**	100 Ohm-RTD (low) -130 to 392°F -90 to 200°C
	100 T***	100 Ohm-RTD (special) -238 to 482°F -150 to 250°C
	4-20	4 to 20 Milliamps
	10m	0 to 10 Millivolts
	100m*	0 to 100 Millivolts or 0 to 200 Millivolts
	0-1	0 to 1 Volt
	1-5	1 to 5 Volt
	0-5	0 to 5 Volt
	0-10	0 to 10 Volts
<p>* For 200mV actuation, select 100m and be sure hardware configuration is correct. ** IEC = 0.0385 *** ITS-48 = 0.0391</p>		

Table 4-5 is continued on next page

4.8 Input Parameters Set Up Group, Continued

Table 4-5 Input Parameters Group, continued

Lower Display Prompt	Upper Display Range of Setting or Selection	Parameter Definition
INPHI	-999 to 9999	<p>INPUT HIGH RANGE VALUE in engineering units is displayed but can only be configured for linear input type.</p> <p>Otherwise, this is a read-only display of the higher range value for the selected T/C or RTD input type.</p> <ul style="list-style-type: none"> Scale the input signal to the display value you want for 100%. EXAMPLE: Actuation (Input) = 4 to 20 mA Process Variable = Flow Range of Flow = 0 to 250 Gal/Min High Range display value = 250 Then 20 mA = 250 Gal/Min
INPLO	-999 to 9999 in Engineering units	<p>INPUT LOW RANGE VALUE in engineering units is displayed but can only be configured for linear input type.</p> <ul style="list-style-type: none"> Otherwise, this is a read-only display of the low range value for the selected T/C or RTD input type. Scale the input signal to the display value you want for 0%. See example in "INPHI".
BIAS	-99.9 to 999.9	<p>INPUT BIAS — used to compensate the input for drift of an input value due to deterioration of a sensor, or some other cause; select the value you want on the input.</p>
FILTER	0 to 120 seconds No filter = 0	<p>FILTER FOR INPUT — a software digital filter is provided for the input to smooth the input signal. You can configure the first order lag time constant from 1 to 120 seconds. If you do not want filtering, enter 0.</p>

Table 4-5 is continued on next page

4.8 Input Parameters Set Up Group, Continued

Table 4-5 Input Parameters Group, continued

Lower Display Prompt	Upper Display Range of Setting or Selection	Parameter Definition
BRNOUT	<p>NONE</p> <p>UP</p> <p>DOWN</p>	<p>BURNOUT PROTECTION (SENSOR BREAK) provides most input types with upscale or downscale protection if the input fails.</p> <p>ATTENTION Be sure jumper installation on the Main printed circuit board matches selection made here. See <i>Section 2 - SET UP TASKS</i>.</p> <p>NO BURNOUT — Failsafe output applied for failed input.</p> <p>UPSCALE BURNOUT will make the indicated PV signal increase when a sensor fails, and flash the lower display.</p> <p>DOWNSCALE BURNOUT will make the indicated PV signal decrease when a sensor fails, and flash the lower display.</p> <p>NOTE: For no Burnout, (that is, "None,") to function properly on a linear input, there must be a dropping resistor directly across the <i>input</i> terminals, then the unit can detect the "zero" voltage that occurs when the 4-20 mA line is opened. When the input goes out of range, the lower display will flash.</p>

4.9 Total Parameters Set Up Group

Introduction

The functions listed in this group deal with the calculation and display of the total flow volume as measured by the input. The displayed value is six digits with a configurable scale factor. For a 2-pen recorder, the desired input channel is displayed on the left side of the operator interface. Press **[FUNC]** key to select channel. These prompts appear only if Model Table II includes Totalization option..

Totalizer group prompts Table 4-6 lists all the function prompts in the “TOTAL” Set Up group. Press **[SETUP]** key until “TOTAL” appears in the display. Press **[FUNC]** to select the parameters.

Table 4-6 Totalizer Parameter Group Definitions

Lower Display Prompt	Upper Display Range of Setting or Selection	Parameter Definition
(Actual Current totalized value)	(Current scale factor) Example: E1	VIEW CURRENT TOTALIZED VALUE — this selection lets you view the current totalized value. <ul style="list-style-type: none"> In the example shown, E1 represents exponential value of total (total times 10¹). See “SCALER” function prompt in this group for selections.
RESET	YES NO	RESET TOTALIZER TO ZERO — this selection lets you reset the totalizer to zero. <ul style="list-style-type: none"> Selecting YES will reset the totalizer to zero. [ATTENTION] Prompt “RSTABL” must = YES to reset.
TOTAL	ENAB DIS	TOTALIZATION FOR INPUT — this selection allows you to enable or disable the totalizer function. The prompt appears first if “DIS” is selected. <ul style="list-style-type: none"> ENABLE allows selection of the rest of the prompts associated with totalization.
RATE	SEC MIN HOUR DAY MDAY	RATE OF INTEGRATION — This selection allows you to select the desired rate of integration. <p>SECOND - EU (Engineering Units) per second MINUTE - EU per minute HOUR - EU per hour DAY - EU per day MDAY - Millions of Units per day</p>

Table 4-6 is continued on next page

4.9 Total Parameters Set Up Group, Continued

Totalizer group prompts, continued

Table 4-6 Totalizer Parameter Group, continued

Lower Display Prompt	Upper Display Range of Setting or Selection	Parameter Definition
<p>SCALER</p>	<p>1 10 100 1000 1E4 1E5 1E6 1E7 1E8</p>	<p>TOTALIZER SCALE FACTOR — The totalizer displays the current totalized flow value (up to 6 digits maximum). Seven scaling factors are available (from 1 to 1 Million).</p> <ul style="list-style-type: none"> • The desired scaling factor is applied to the calculated value to extend the maximum flow range that can be displayed. • 1E4 equals 1 times 10.4 (10,000) • 1E5 equals 1 times 10.5 (100,000) • 1E6 equals 1 times 10.6 (1,000,000) • 1E7 equals 1 times 10.7 (10,000,000) • 1E8 equals 1 times 10.8 (100,000,000)
<p>RSTABL</p>	<p>NO YES</p>	<p>TOTALIZER RESET— this selection (YES) allows the totalizer value to be reset. See “RESET” prompt.</p>

4.10 Output Set Up Group

Introduction

This data deals with the output configuration. It allows you to enable the “OUTPUT” and “CONTRL” prompts for configuration and select the output type “ALRM” or “CTRL”.

Function prompts

Table 4-7 lists all the function prompts in the “OUTPUT” set up group.

- Press the **SETUP** key until “OUTPUT” appears in the display.

For a 2-pen recorder, the desired input channel is displayed on the left side of the operator interface. Press **FUNC** to select channel.

Table 4-7 Output Group Function Prompts

Lower Display Prompt	Upper Display Range of Setting or Selection	Parameter Definition
OUTPUT	ENAB DIS	<p>OUTPUT SELECTION — this selection allows the “OUTPUT” or “CONTROL” prompts to appear if ENAB is selected.</p> <p>ENABLE - allows rest of prompts associated with output.</p> <p>DISABLE - no other “OUTPUT” or “CONTROL” prompts appear.</p>
OUTTYP	ALRM CTRL	<p>OUTPUT TYPE — select type of output</p> <p>ATTENTION Only applicable for Model Table 1 = 1X, X1, 2X, or X2. Do you want to use control or alarm output?</p> <p>ALARM - if you select alarm then “CONTRL”, “TUNING”, and “CYCLE” group prompts will not appear.</p> <p>CONTROL - you can have second alarm output with control, if function prompt “OUTALG” in set up group “CONTRL” = RLY or CUR.</p>

4.11 Control Parameters Set Up Group

Introduction

The functions listed in this group deal with how the recorder will control the process.

Control group prompts

Table 4-8 lists all the function prompts in the Control set up group. You can enable the control group in the "OUTPUT" set up group under function prompt "OUTTYP".

For a 2-pen recorder, the desired input channel is displayed on the left side of the operator interface. Press **FUNC** to select channel.

- Press **SETUP** key until "CONTRL" appears in the lower display.
- Press **FUNC** key to select the parameters.

www.DataSheet4U.com

Table 4-8 Control Parameter Group

Lower Display Prompt	Upper Display Range of Setting or Selection	Parameter Definition
OUT ALG	RLY	<p>The OUTPUT ALGORITHM lets you select the type of output you want. Do you want the OUTPUT algorithm for control to be relay simplex, relay duplex, or current simplex.</p> <p>ATTENTION Be sure that the hardware configuration is set to provide relay or current output. See <i>Section 2- Setup Tasks</i>.</p> <p>RELAY SIMPLEX — type of output using one SPDT relay. Its normally open (NO) or normally closed (NC) contacts are selected by positioning an internal jumper.</p> <ul style="list-style-type: none"> • Other prompts affected: "HYST"
	CUR	<p>CURRENT SIMPLEX — type of output using one 4 to 20 mA signal that can be fed into a positive or negative grounded load of 0 to 600 ohms. The signal can be re-calibrated for any desired range from 4 to 20 mA for 0 to 100% output.</p>
	RLYD	<p>RELAY DUPLEX — type of output using two SPDT relays. Its normally open (NO) or normally closed (NC) contacts are selected by positioning an internal jumper (see <i>Section 2 - Setup Tasks</i>).</p> <ul style="list-style-type: none"> • Other prompts affected: "DEADBAND"

Table 4-8 is continued on next page

4.11 Control Parameters Set Up Group, Continued

Table 4-8 Control Parameter Group, continued

Lower Display Prompt	Upper Display Range of Setting or Selection	Parameter Definition
CONT ALG (continued)	PDMR	<p>PD WITH MANUAL RESET is used whenever integral action is not wanted for automatic control. The equation is computed with no integral contribution. The MANUAL RESET, which is operator adjustable, is then added to the present output to form the controller output. Switching between manual and automatic mode will not be bumpless.</p> <ul style="list-style-type: none"> If you select PD with Manual Reset you can also configure the following variations: <ul style="list-style-type: none"> PD (Two Mode) control, P (Single Mode) control. <p>Set Rate T(D) and/or Reset Time(I) to 0. Other prompts affected: "MAN RSET" in "TUNING" set up group.</p>
PWR UP	MAN AUTO	<p>POWER UP CONTROLLER MODE RECALL — this selection determines which mode the recorder will use when the it restarts after a power loss. Select one from below:</p> <ul style="list-style-type: none"> MANUAL, LSP — at power-up, the recorder will use <i>manual</i> mode with the output value displayed. AUTOMATIC — at power-up, the recorder will return to the <i>automatic mode</i>.
SP HI	-999 to 9999	SETPOINT HIGH LIMIT* — this selection prevents the local setpoint from going above the value selected here. The setting must be equal to or less than the upper range of the input.
SP LO	-999 to 9999	SET POINT LOW LIMIT* — this selection prevents the local setpoint from going below the value selected here. The setting must be equal to or greater than the lower range of the input.
ACTION	DIR RE	<p>CONTROL OUTPUT DIRECTION — in what direction do you want the recorder output to go when the process variable increases.</p> <p>DIRECT ACTING CONTROL — the recorder's output <u>increases</u> as the process variable increases.</p> <p>REVERSE ACTING CONTROL — the recorder's output <u>decreases</u> as the process variable increases.</p>
OUTH1**	0 to 100.0% of output -5 to 105% for current output	HIGH OUTPUT LIMIT — this is the highest value of output beyond which you do not want the recorder automatic output to exceed. Use 0 to 100% for relay output type.

* The Setpoint will automatically adjust itself to be within the setpoint limit range. For example, if SP = 1500 and the SP HI is changed to 1200, the new setpoint will be 1200.

** These prompts will only appear when function prompt OUTALG in the "OUTPUT" set up group = PIDA or PDMR

Table 4-8 is continued on next page

4.11 Control Parameters Set Up Group, Continued

Table 4-8 Control Parameter Group, continued

Lower Display Prompt	Upper Display Range of Setting or Selection	Parameter Definition
OUTLO**	0 to 100.0% of output -5 to 105% for current output	LOW OUTPUT LIMIT — this is the lowest value of output below which you do not want the recorder automatic output to exceed. Use 0 to 100% for relay output type.
DBAND	-5.0 to 25.0% 0 to 25.0%	DEADBAND is an adjustable gap between the operating ranges of relay 1 and relay 2 in which neither relay operates (positive value) or both relays operate (negative value). It is the difference between the nominal trip points of relay 1 and relay 2. This prompts appears only if function prompt "OUTALG" is "RLY D." Time Duplex On-Off Duplex
HYST	0.0 to 5.0% of PV span	HYSTERESIS (OUTPUT RELAY ONLY) is an adjustable overlap of the ON/OFF states of each control relay. This is the difference between the value of the process variable at which the control relays energize and the value at which they de-energize. Only applicable for ON-OFF control.
FAILSF	0 to 100%	FAILSAFE OUTPUT VALUE — select the value you want the output to be when power is returned after a power down. The value used here will also be the output level when NO BURNOUT is configured and the input circuit fails.
PBorGN	PB GAIN	PROPORTIONAL BAND UNITS — select one of the following for the Proportional (P) term of the PID or PDMR algorithm: • PROPORTIONAL BAND — selects units of percent proportional band for the P term of the PID or PDMR algorithm, where: $PB\% = \frac{100\%FS}{GAIN}$ • GAIN selects the unitless term of gain for the P term of the PID algorithm, where: $GAIN = \frac{100\%FS}{PB\%}$
MINRPM	RPM MIN	RESET UNITS — selects units of minutes or repeat per minutes for the I term of the PID algorithm. 20 Repeats per Minute = 0.05 Minutes per Repeat. REPEATS PER MINUTE — the number of times per minute that the proportional action is repeated by reset. MINUTES PER REPEAT — the time between each repeat of the proportional action by reset.

** These prompts will only appear when function prompt OUTALG in the "OUTPUT" set up group = PIDA or PDMR

4.12 Tuning Parameters Set Up Group

Introduction

Tuning consists of establishing the appropriate values for the tuning constants you are using so that your recorder responds correctly to changes in process variable and setpoint. You can start with predetermined values but you will have to watch the system to see how to modify them. There are two Tuning groups available.

These prompts are available of Model Table I = 1X or X1 and function prompt "CTRALG" under setup group "CONTL" = PIDA or PDMR.

Tuning group prompts Table 4-9 lists all the function prompts in the Tuning set up group.

For a 2-pen recorder, the desired input channel is displayed on the left side of the operator interface. Press **FUNC** key to display channel.

- Press **SETUP** key until "TUNING" appears in the lower display.
- Press **FUNC** key to select the parameters.

Table 4-9 Tuning Parameters Group

Lower Display Prompt	Upper Display Range of Setting or Selection	Parameter Definition
Pb or GAIN	0.1 to 999.9% or 0.1 to 999.9	<p>PROPORTIONAL BAND is the percent of the range of the measured variable for which a proportional recorder will produce a 100% change in its output.</p> <p>GAIN is the ratio of output change (%) over the measured variable change (%) that caused it.</p> $G = \frac{100\%}{PB\%}$ <p>where PB is the proportional band (in %) if the PB is 20%, then the Gain is 5. Likewise, a 3% change in the error signal (SP-PV) will result in a 15% change in the recorder's output due to proportional action. If the gain is 2, then the PB is 50%.</p> <ul style="list-style-type: none"> • Used with control algorithm PID-A or PDMR. Defined as "HEAT" Gain on Duplex models for variations of Heat/Cool applications. • The selection of Proportional Band or Gain is made in the "Contrl" parameter group under prompt "PBoRGN."
RATE T	0.08 to 10.00 minutes 0.08 or less = OFF	<p>RATE action affects the recorder's output whenever the deviation is changing; and affects it more when the deviation is changing faster.</p> <ul style="list-style-type: none"> • Used with control algorithm PID-A. Defined as "HEAT" Rate on Duplex models for variations of Heat/Cool applications.

Table 4-9 is continued on next page

4.12 Tuning Parameters Set Up Group, Continued

Table 4-9 Tuning Parameters Group, continued

Lower Display Prompt	Upper Display Range of Setting or Selection	Parameter Definition
I MIN or I RPM	0.02 to 50.00	<p>RSET MIN = RESET IN MINUTES / REPEAT RSET RPM = RESET IN REPEATS / MINUTE</p> <p>RESET adjusts the recorder's output in accordance with both the size of the deviation (SP-PV) and the time it lasts. The amount of the corrective action depends on the value of Gain. The Reset adjustment is measured as how many times proportional action is repeated/minute.</p> <ul style="list-style-type: none"> • Used with control algorithm PID-A or PID-B. Defined as "HEAT" Reset on Duplex models for variations of Heat/Cool applications. • The selection of minutes per repeat or repeats per minute is made in the "CONTRL" parameters group under prompt "MINRPM."
MAN RST	-100 to +100 (in % output)	<p>MANUAL RESET is only applicable if you have control algorithm PD WITH MANUAL RESET (PDMR). Because a proportional recorder will not necessarily line out at setpoint, there will be a deviation (offset) from setpoint. This eliminates the offset and lets the PV line out at setpoint.</p>
Pb2 or GAIN 2	0.1 to 1000% or 0.1 to 1000	<p>PROPORTIONAL BAND 2 or GAIN 2, RATE 2T, and I2. RPM or MIN parameters are the same as previously described for "Heat" except that they refer to the cool zone tuning constants on duplex models or the second set of PID constants, whichever is pertinent.</p>
RATE2T	0.08 to 10.00 minutes 0.08 or less = OFF	
I2MIN I2RPM	0.02 to 50.00	

4.13 Cycle Parameters Set Up Group

Introduction

This data with the output relay cycle time for time proportional output and “Heat” relay in duplex application.

These prompts only appear if function prompt “OUTALG” in set up group.

“CONTRL” = RLY or RLYD and function prompt “CTRALG” in set up group

“CONTRL” = PIDA or PDMR.

Cycle group prompts

Table 4-10 lists all the function prompts in the “Cycle” set up group.

For a 2-pen recorder, the desired input channel is displayed on the left side of the operator interface. Press **FUNC** key to display channel.

- Press **SETUP** key until “CYCLE” appears in the lower display.
- Press **FUNC** key to select the parameters.

Table 4-10 Cycle Parameters Group

Lower Display Prompt	Upper Display Range of Setting or Selection	Parameter Definition
CYC TI	0 to 120 seconds	CYCLE TIME for RELAY 1 - This sets the output relay cycle time for time proportional output. Use for heat relay in duplex applications.
CYC2TI	0 to 120 seconds	CYCLE TIME FOR RELAY 2 - This selection is used when function prompt “OUTALG” in “CONTRL” set up group = RLYD. It sets the output relay cycle time for cool relay in duplex application.

4.14 Alarms Set Up Group

Introduction

An alarm is an indication that an event that you have configured (for example—Process Variable) has exceeded one or more alarm limits. There are two alarms available. Each alarm has two setpoints. You can configure each of these two setpoints to alarm on the input PV. There are two alarm output selections, high and low. You can configure each setpoint to alarm either high or low. These are called single alarms. You can also configure the two setpoints to alarm on the PV and to alarm both high and low. A single adjustable hysteresis of 0.0% to 5.0% is configurable for the alarm setpoint.

Alarms group prompts

Table 4-11 lists all the function prompts in the Alarms set up group and their definitions.

For a 2-pen recorder, the desired input channel is displayed on the left side of the operator interface. Press **FUNC** to select channel.

- Press **SETUP** key until “ALARMS” appears in the lower display.
- Press **FUNC** key to select the parameters.

Table 4-11 Alarms Group Definitions

Lower Display Prompt	Upper Display Range of Setting or Selection	Parameter Definition
A1S1TY	NONE INP	ALARM 1 SETPOINT 1 TYPE — select what you want Setpoint 1 of Alarm 1 to represent. It will represent the Input. NO ALARM INPUT PV
A1S2TY	Same as A1S1 TY	ALARM 1 SETPOINT 2 TYPE — select what you want Setpoint 2 of Alarm 1 to represent. The selections are the same as A1S1TY.
A1S1 VA	-999 to 9999	ALARM 1 SETPOINT 1 VALUE — this is the value at which you want the alarm type chosen in prompt "A1S1TY" to actuate. The value depends on what the setpoint has been configured to represent.

Table 4-11 is continued on next page

4.14 Alarms Set Up Group, Continued

Table 4-11 Alarms Group Definitions, continued

Lower Display Prompt	Upper Display Range of Setting or Selection	Parameter Definition
A1S2 VA	-999 to 9999	ALARM 1 SETPOINT 2 VALUE — this is the value at which you want the alarm type chosen in prompt "A1S2TY" to actuate. • The details are the same as "A1S1 VA".
A1S1 H L	HI LO	ALARM 1 SETPOINT 1 STATE — select whether you want the alarm type chosen in prompt "A1S1TY" to alarm high or low. HI ALARM - Relay coil is de-energized when the PV is above the Setpoint. LO ALARM - Relay coil is de-energized when the PV is below the Setpoint.
A1S2 H L	HI LO	ALARM 1 SETPOINT 2 STATE — select whether you want the alarm type chosen in prompt "A1S2TY" to alarm high or low. HI ALARM - Relay coil is de-energized when the PV is above the Setpoint. LO ALARM - Relay coil is de-energized when the PV is below the Setpoint.
A2S1TY	Same as A1S1 TY	ALARM 2 SETPOINT 1 TYPE — select what you want Setpoint 1 of Alarm 2 to represent. The selections are the same as A1S1TY. NOTE: Not applicable with Relay Duplex outputs.
A2S2TY	Same as A1S1 TY	ALARM 2 SETPOINT 2 TYPE — select what you want Setpoint 2 of Alarm 2 to represent. The selections are the same as A1S1TY. NOTE: Not applicable with Relay Duplex outputs.
A2S1 VA	-999 to 9999	ALARM 2 SETPOINT 1 VALUE — this is the value at which you want the alarm type chosen in prompt "A2S1TY" to actuate. • The details are the same as "A1S1 VA".
A2S2 VA	-999 to 9999	ALARM 2 SETPOINT 2 VALUE — this is the value at which you want the alarm type chosen in prompt "A2S2TY" to actuate. • The details are the same as "A1S1 VA".

Table 4-11 is continued on next page

4.14 Alarms Set Up Group, Continued

Table 4-11 Alarms Group Definitions, continued

Lower Display Prompt	Upper Display Range of Setting or Selection	Parameter Definition
A2S1 H L	H I LO	<p>ALARM 2 SETPOINT 1 STATE — select whether you want the alarm type chosen in prompt "A2S1TY" to alarm high or low.</p> <p>HI ALARM - Relay coil is de-energized when the PV is above the Setpoint.</p> <p>LO ALARM - Relay coil is de-energized when the PV is below the Setpoint.</p>
A2S2 H L	H I LO	<p>ALARM 2 SET POINT 2 STATE — select whether you want the alarm type chosen in prompt "A2S2TY" to alarm high or low.</p> <p>HI ALARM - Relay coil is de-energized when the PV is above the Setpoint.</p> <p>LO ALARM - Relay coil is de-energized when the PV is below the Setpoint.</p>
AL HYS	0.0 to 5.0% of span or full output as appropriate	<p>ALARM HYSTERESIS — a single adjustable hysteresis is provided on alarms such that when the alarm is OFF it activates at exactly the alarm setpoint; when the alarm is ON, it will not deactivate until the variable is 0.0% to 5.0% away from the alarm setpoint.</p> <ul style="list-style-type: none"> • Configure the hysteresis of the alarms based on INPUT signals as a % of input range span. • Configure the hysteresis of the alarm based on OUTPUT signals as a % of the full scale output range.

4.15 Lock Parameters Set Up Group

Introduction

These are the parameters that you will set to lockout any unauthorized changes to the recorder's configuration and calibration prompts.

Set this group last

Because this group contains functions that have to do with security and lockout, we recommend that you configure this group last, after all the other configuration data has been loaded.

Lockout group prompts Table 4-12 lists all the function prompts in the Lock set up group.

- Press **SETUP** key until "LOCK" appears in the lower display.
- Press **FUNC** key to select the parameters.

www.DataSheet4U.com

Table 4-12 Lockout Group Definitions

Lower Display Prompt	Upper Display Range of Setting or Selection	Parameter Definition
LOCK	NONE CAL CONF FULL	<p>LOCK applies to one of the functional groups: Configuration or Calibration. DO NOT CONFIGURE UNTIL ALL CONFIGURATION IS COMPLETE.</p> <p>No Lockout – all groups read/write.</p> <p>CAL – All are available for read/write except for the Calibration group.</p> <p>CONF – Tuning is read/write. All other groups are read only. Calibration group is not available.</p> <p>FULL – Calibration group not available. All other groups are Read-only.</p>

4.16 Configuration Record Sheet

Keep a record

Enter the value or selection for each prompt on this sheet so you will have a record of how your recorder was configured.

Group Prompt	Function Prompt	Value or Selection	Group Prompt	Function Prompt	Value or Selection
CHART	CHRTSPD	_____	TUNING	Pb	_____
	HOUR/REV	_____		or	_____
	CHTTYP	_____		GAIN	_____
PEN	PENIN	_____		RATE T	_____
	CHARTHI	_____		I MIN	_____
	CHARTLO	_____		or	_____
INPUT 1	DECIMAL	_____		I RPM	_____
	UNITS	_____		or	_____
	IN1 TYPE	_____		MAN RST	_____
	INP HI	_____		Pb2	_____
	INP LO	_____		or	_____
	BIAS	_____	GAIN 2	_____	
	FILTER	_____	RATE2T	_____	
	BRNOUT	_____	I2MIN	_____	
TOTAL	(Value)	_____	or	_____	
	RESET	_____	I2RPM	_____	
	TOTAL	_____	CYCLE	CYCTI	_____
	RATE	_____	CYC2TI	_____	
	SCALER	_____	ALARMS	A1S1TY	_____
	RSTABL	_____		A1S2TY	_____
OUTPUT	OUTPUT	_____		A1S1 VA	_____
	OUTTYP	_____		A1S2 VA	_____
CONTROL	OUTALG	_____		A1S1 HL	_____
	CTRALG	_____		A1S2 HL	_____
	PWRUP	_____		A2S1TY	_____
	SP HI	_____		A2S2TY	_____
	SP LO	_____		A2S1 VA	_____
	ACTION	_____		A2S2 VA	_____
	OUT HI	_____	A2S1 HL	_____	
	OUT LO	_____	A2S2 HL	_____	
	DBAND	_____	AL HYS	_____	
	HYST	_____	LOCK	LOCK	_____
	FAILSF	_____			
	PBorGN	_____			
	MINRPM	_____			

Section 5 – Operation and Maintenance

5.1 Overview

Introduction

This section provides procedures and reference data for operating the recorder and for doing routine maintenance tasks. It assumes that the recorder has been properly prepared, mounted, wired and configured in accordance with the instructions in Sections 2, 3, and 4.

Some of the procedures in this section are required only initially, and some are required randomly, as conditions dictate. Once the recorder is up and running, operator actions are required infrequently and are straightforward.

www.DataSheet4U.com

What's in this section?

This section contains the following information:

	Topic	See Page
5.1	Overview	73
5.2	Preparing the Recorder for Operation	74
5.3	Running the Optional Self-Test	75
5.4	Start-up	76
5.5	Monitoring Your Recorder	82
5.6	Operator Functions	86
5.7	Operating Modes	87
5.8	Changing the Control Setpoint	89
5.9	Alarm Setpoints	90
5.10	Resetting the Totalizer Value	91
5.11	Changing the Input Type and Restoring Factory of Field Calibration Values	92
5.12	Maximizing Pen Life	94
5.13	Routine Maintenance	95



WARNING—SHOCK HAZARD



START-UP AND MAINTENANCE MAY REQUIRE ACCESS TO HAZARDOUS LIVE CIRCUITS, AND SHOULD ONLY BE PERFORMED BY QUALIFIED SERVICE PERSONNEL. MORE THAN ONE SWITCH MAY BE REQUIRED TO DE-ENERGIZE UNIT BEFORE SERVICING.

5.2 Preparing the Recorder for Operation

Introduction

Before applying power to the recorder, complete these preliminary preparation tasks to prepare your recorder for operation.

ATTENTION If you ran the Pre-Setup Operational Check, you can skip this procedure.

WARNING Never access components inside the case with power applied.

Procedure

Refer to Figure 5-1 to identify the basic chart plate components and follow the procedure in Table 5-1 to prepare the recorder for operation.

Table 5-1 Preparing the Recorder for Operation

Step	Action
1	Push in the button on the door and swing it open.
2	Pull up on the pen lifter to raise the pen(s) from the chart plate and remove the protective cap from the pen tip.
3	Slip the new chart under the pen lifter, pen and time index, and press it into place over the chart hub and locating pin.
4	Be sure that the line voltage rating matches the recorder's power requirement (see <i>Section 2 - Setup Tasks</i>).

Figure 5-1 Basic Chart Plate Components

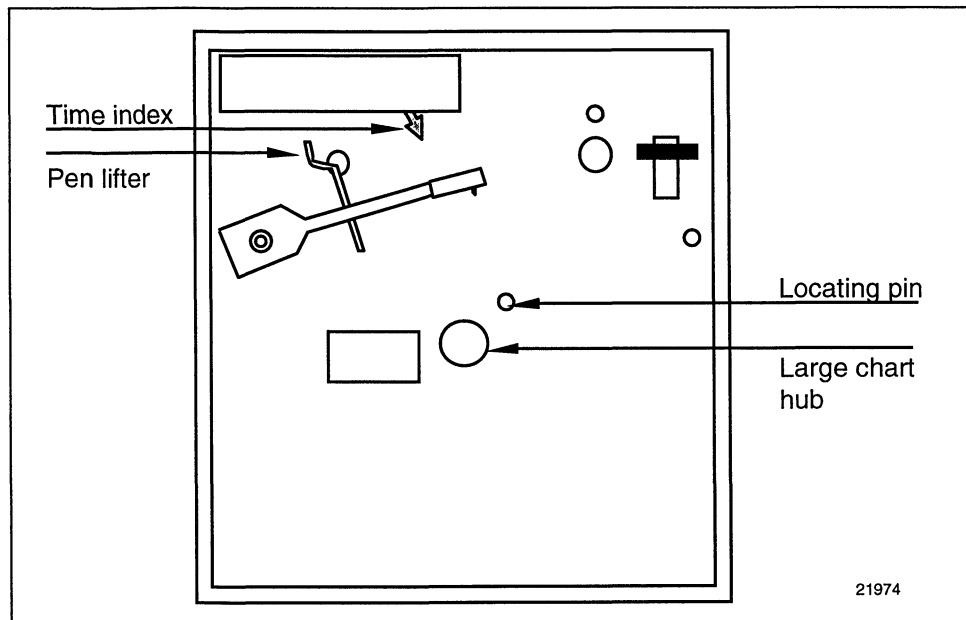

5.3 Running the Optional Self-Test

Introduction

You can have the recorder run its self-test when power is applied by initiating the test from the keyboard.

This test verifies that the electronic components and the pen and chart drive functions are operating properly by printing a step pattern, which is independent of any chart settings, with horizontal lines drawn at each 10% increment on the chart.

The test will run for one complete revolution of the chart, so it will take a while to complete.

You do not have to run the self-test before putting the recorder into operation, but doing so will verify the general operational status of the recorder.

CAUTION If your recorder has control/alarm output, the relay(s) will be turned ON/OFF during the self-test. Be sure your process can tolerate some upsets during the self-test cycle, or disconnect the output wiring.

www.DataSheet4U.com

Procedure

Refer to the procedure in Table 5-2 to run the self-test.

ATTENTION You can interrupt the self-test cycle at any time.

Press the **DISP** key.

Table 5-2 Running the Self-Test

Step	Press	Action/Result
1		Make sure the cap is removed from the pen tip and the chart is installed.
2	FUNC	Until INP1 indicator is lit on the left side of the operator interface.
3	DISP and MAN AUTO together	You will see: Upper Display PASS Lower Display SLF TST ATTENTION The OUT "1" and/or "2" indicators will blink on and off at the rate the relays are being energized, if the relay outputs have been configured.
4		Check periodically to see that the recorder is generating a step pattern on the chart as shown in Figure 5-2. At the completion of the self-test, the recorder automatically returns to normal operation.
5	FUNC	to light INP2 indicator (if recorder has 2 pens) You will see: Upper Display (value) Lower Display INP2 Repeat step 3 & 4 to test pen 2 operation.
6	DISP	to abort the self test.

5.3 Running the Optional Self-Test, Continued

Chart step pattern

Figure 5-2 is a typical chart step pattern generated by the recorder in the self-test.

Figure 5-2 Typical Chart Step Pattern

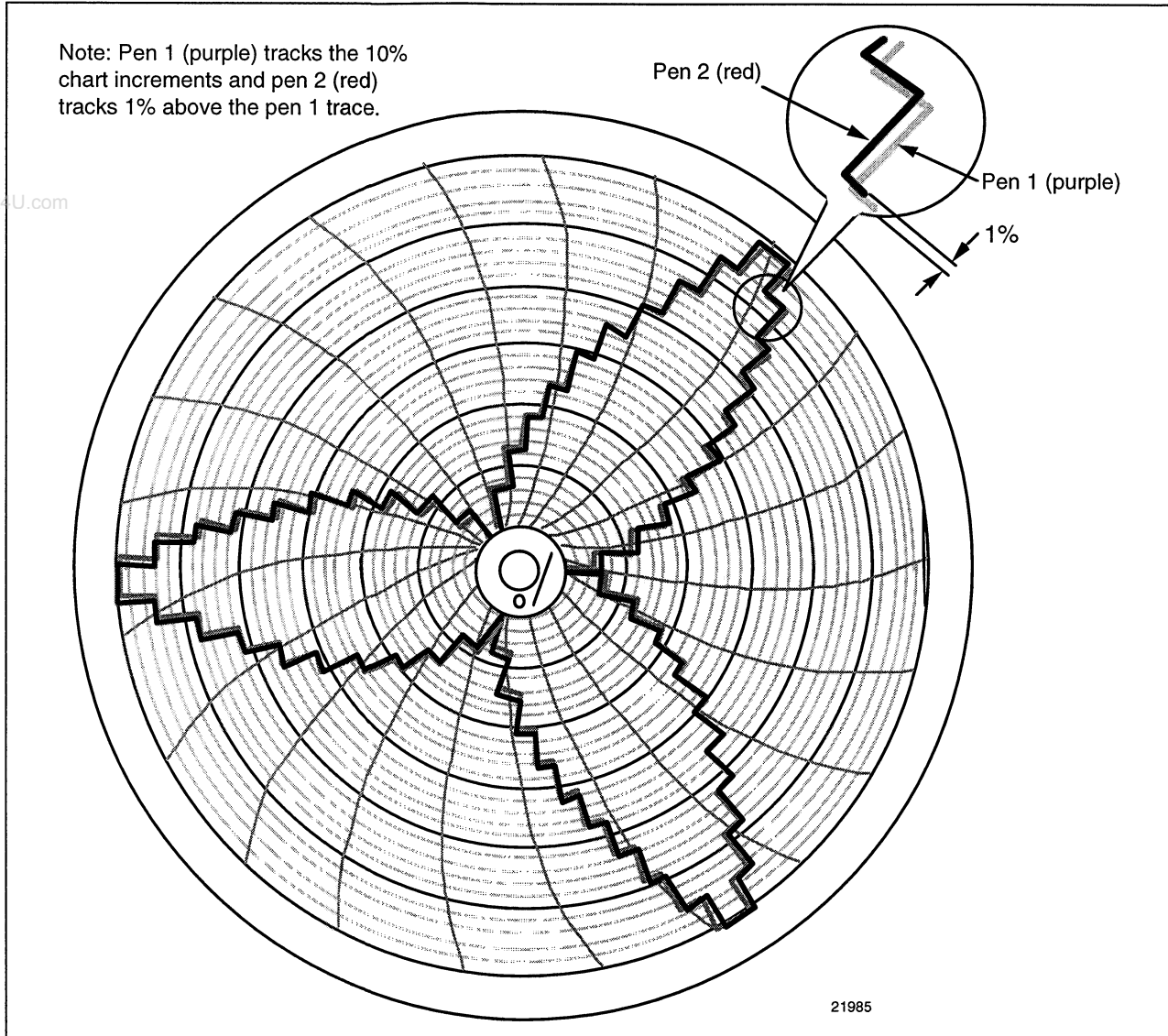

5.4 Start-up

Introduction

Once the recorder is setup, mounted, wired, has had the chart installed and the operating parameters are set, you only have to:

- set the chart time
- apply the power
- check the diagnostics tests
- check the displays and keys

Set chart time and apply power

Refer to Figure 5-3 for the component locations and follow the procedure in Table 5-3. Set the chart time and apply power.

Table 5-3 Set Chart Time and Apply Power Procedure

Step	Action
1	Push in the button on the door and swing it open.
2	Pull up the pen lifter to raise the pen(s) from the chart plate.
3	Grasp the chart hub and locating pin and turn the chart until the desired time line on the chart is aligned with the time index on the chart plate and Pen #1. Push down the pen lifter to return the pen(s) to the chart.
4	Close the door and apply power.
5	The recorder pen will start to track the input value, after pen initialization.

Figure 5-3 Setting Chart Time to Time Index

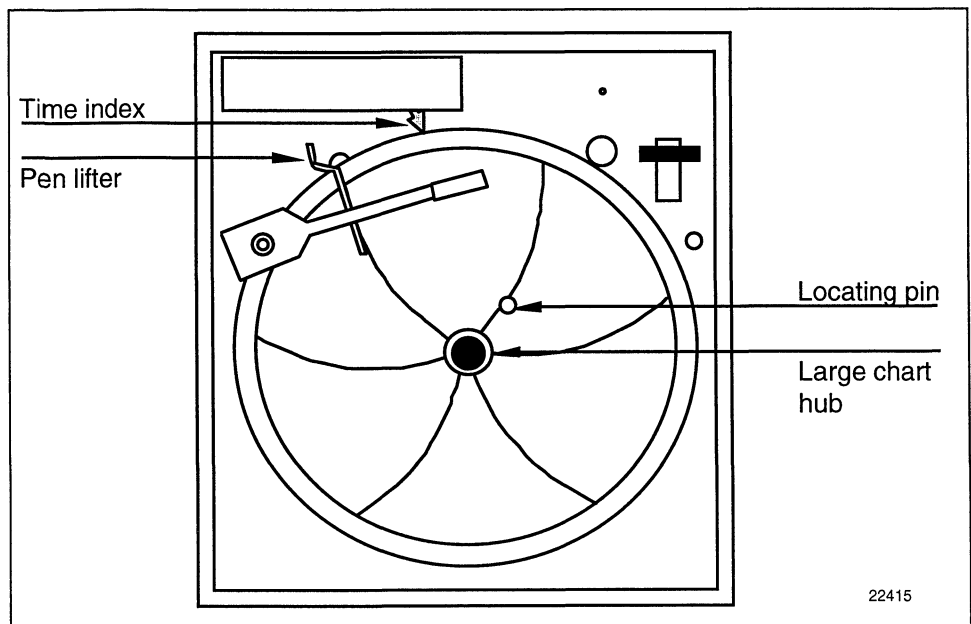

5.4 Start-up, Continued

Diagnostic tests

When power is applied, the recorder will run four diagnostic tests. Table 5-4 lists the four diagnostic tests.

Table 5-4 Power Up Diagnostic Tests

Prompt on Lower Display	Condition
RAMTST	Check RAM
CFGTST	Check nonvolatile memory
CALTEST	Check calibration
BATTERY (if totalizer option is installed)	Check the battery

The display and indicators will all light. Make sure all display segments and indicators are lit.

Test failures

If one or more of these tests fail, the recorder will go to the Fail-safe Manual Mode, and “FAILSF” will flash in the lower display.

Troubleshooting

Refer to “STATUS TESTS” in *Section 7 - Troubleshooting /Service* to identify and correct the problem.

Continued on next page

5.4 Start-up, Continued

Check the displays and keys Use the procedure in Table 5-5 to run the display and key test.

Table 5-5 Procedure for Testing the Displays and Keys

Press	Result														
<p style="text-align: center;"> <div style="border: 1px solid black; padding: 2px; display: inline-block; margin-bottom: 5px;">SET UP</div> and hold in, then <div style="border: 1px solid black; padding: 2px; display: inline-block; margin-top: 5px;">FUNC</div> at the same time </p>	<p>The recorder runs a display test. All the displays will light for 8 seconds, then the displays will look like this:</p> <p>Upper Display <div style="border: 1px solid black; padding: 2px; display: inline-block; margin-left: 20px;">KEYS</div></p> <p>Lower Display <div style="border: 1px solid black; padding: 2px; display: inline-block; margin-left: 20px;">TRY</div></p>														
<p>Press each key to see if it works</p>	<p>When the key is pressed, the lower display indicates the name of the key pressed.</p> <table border="1" data-bbox="873 831 1419 1083"> <thead> <tr> <th>Key Pressed</th> <th>Lower Display</th> </tr> </thead> <tbody> <tr> <td>SET UP</td> <td>SET</td> </tr> <tr> <td>FUNC</td> <td>FUNC</td> </tr> <tr> <td>DISP</td> <td>DISP</td> </tr> <tr> <td>MAN/AUTO</td> <td>AUTO</td> </tr> <tr> <td>▲</td> <td>INCR</td> </tr> <tr> <td>▼</td> <td>DECR</td> </tr> </tbody> </table> <p>If a key doesn't appear, the key is defective - See Section 7 - Troubleshooting /Service</p>	Key Pressed	Lower Display	SET UP	SET	FUNC	FUNC	DISP	DISP	MAN/AUTO	AUTO	▲	INCR	▼	DECR
Key Pressed	Lower Display														
SET UP	SET														
FUNC	FUNC														
DISP	DISP														
MAN/AUTO	AUTO														
▲	INCR														
▼	DECR														

- If no key is pressed for 25 seconds, the test times out and the recorder exits the key test.
- If any test fails, go to subsection 7.3 *Self Diagnostics* for more information.

Key error

When a key is pressed and the prompt "KEY ERROR" appears in the lower display, it will be for one of the following reasons:

- parameter not available,
- not in Set Up mode, press SET UP key first,
- key malfunction, perform keyboard test, and
- control not selected as output type.

Continued on next page

5.4 Start-up, Continued

Start-up procedure

Use the procedure listed in Table 5-6 to start-up the recorder.

Open the recorder door. Apply power and wait for the recorder to run its power-up tests.

ATTENTION

- If FAILSF starts blinking in the lower display, refer to Section 6 for troubleshooting data.
- For recorders with control on both pens, be sure the INP '1' indication is lit for steps 2-6. If INP 1 is not lit, sequentially press the **FUNC** key until "1" is lit when "INP" is displayed.

www.DataSheet4U.com

Table 5-6 Procedure for Starting Up the Recorder





Step	Operation	Press	Action/Result
1	Pen check		For RECORDER ONLY models, just check that the pen is operating and skip to step 6.
2	Select manual mode	MAN AUTO	Until "M" indicator is ON. Be sure INP1 indicator is lit. If it isn't press FUNC key. The recorder is in manual mode and the Output (OUT1) in percent is displayed in the lower display.
		DISP	to call up OUT1 in the lower display
3	Adjust the output	▲ or ▼	Adjust the output value and ensure that the final control element is functioning correctly. Upper Display  Lower Display 
4	Tune the recorder	SET UP	Make sure the recorder has been configured properly and all the values and selections have been recorded on the Configuration Record Sheet. To tune your recorder manually, see <i>Appendix A - Manual Tuning</i> . Refer to Set Up group "TUNING" to ensure that the proper selections for Pb or GAIN, RATE T, and IMIN or IRPM have been entered.

Table 5-6 is continued on next page

5.4 Start-up, Continued

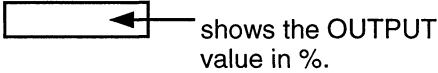
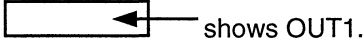
Start-up procedure, continued

Table 5-6 Procedure for Starting Up the Recorder, continued

Step	Operation	Press	Action/Result
5	Enter the setpoint	<div style="border: 1px solid black; padding: 2px; display: inline-block;">DISP</div> until	Upper Display  shows the SP Value Lower Display  SP1 or SP2 (for whichever control setpoint you are setting).
		<div style="text-align: center;">  or  </div>	Adjust the setpoint to the value at which you want the process variable maintained.
6	Select automatic mode	<div style="border: 1px solid black; padding: 2px; display: inline-block;">MAN AUTO</div>	Until "A" indicator is ON. The recorder is in Automatic mode. The recorder will automatically adjust the output to maintain the process variable at setpoint as tracked by the pen trace, if the recorder is properly tuned.
7	Start up Controller #2	<div style="border: 1px solid black; padding: 2px; display: inline-block;">DISP</div> until	"2" is lit when "OUT" is displayed. For recorders with two controllers (both enabled), repeat steps 2-6 for controller #2, but be sure INP "2" indicator is lit instead of INP "1".
8	Exit Start-up		Close the door and monitor the operation.

5.5 Monitoring Your Recorder

Introduction

Besides the historical chart record, you can monitor the recorder's indicators and displays to get an instantaneous view of various process conditions and of the control loop status.

There are also diagnostic error messages to signal detection of malfunctions in certain internally monitored data.

Operator interface

The indicators and displays on the operator interface let you see what is happening to your process and how the recorder is responding.

Figure 5-4 is a view of the operator interface. A description of the displays and indicators is included.

Figure 5-4 Operator Interface

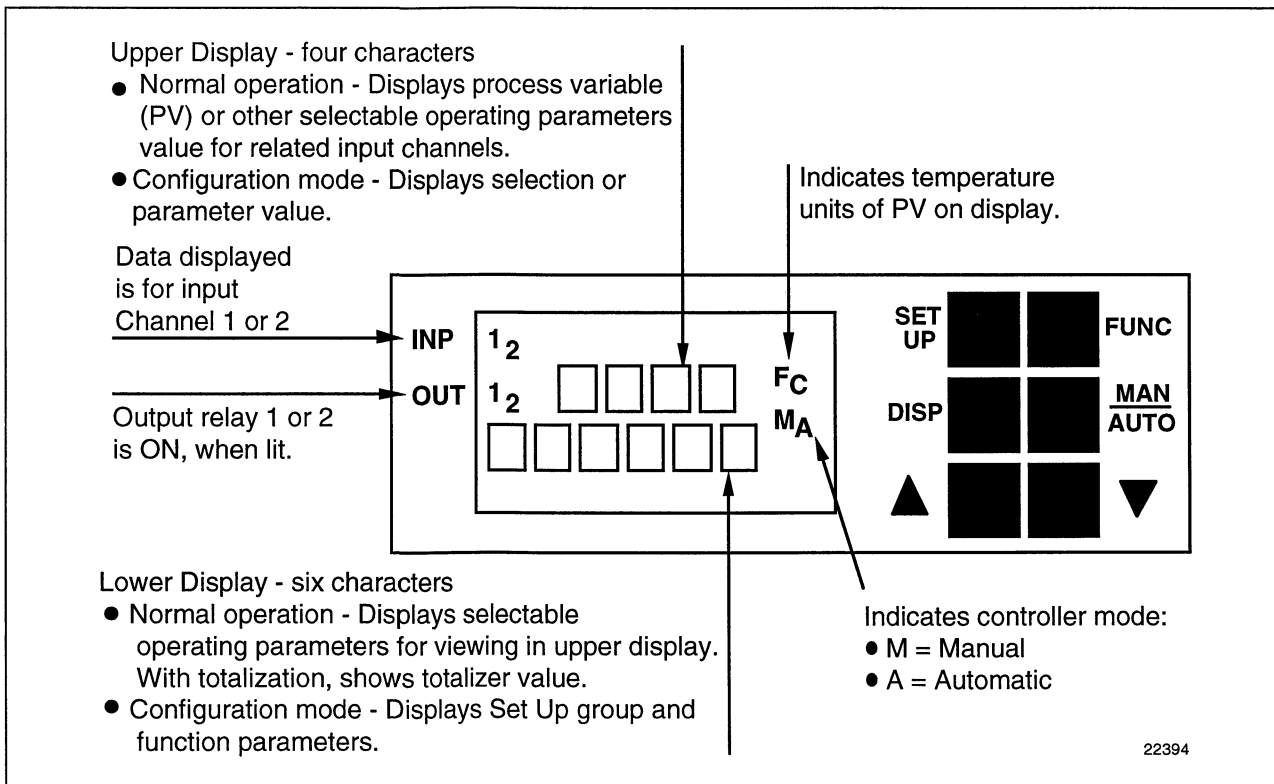

Continued on next page

5.5 Monitoring Your Recorder, Continued

Meaning of indicators During normal operation, the indicators will light for the reasons shown in Table 5-7.

Table 5-7 Meaning of Indicators

Indicator	Definition when lit
INP 1 2	Data displayed is for channel 1 or 2
OUT 1 2	Output relay 1 or 2 is ON
A or M	Indicates the mode of operation: A = Automatic M = Manual
F or C	Indicates the temperature units of PV: F = Fahrenheit C = Celsius
R or L	Not used
KEY ERR (in lower display)	Indicates parameter not available, not in set up mode, or key malfunction.

Continued on next page

5.5 Monitoring Your Recorder, Continued

Viewing the operating parameters

The upper display is a four-character display which shows the value of the PV during normal operation.

- The lower display is an six-character display. During normal operation, you can view various operating parameters. Press the **DISP** key to scroll through the operating parameters listed in Table 5-8.
- The lower display shows only those parameters and its value that apply to your specific model and the way in which it was configured.

For recorders with two pens (both enabled) remember that any controller-related values displayed correspond with the lighted INP indicator.-- “1” means that the values apply for Pen #1 and “2” means that the values apply for Pen #2. Press **FUNC** key to toggle between input 1 and input 2.

www.DataSheet4U.com

Table 5-8 Lower Display Key Parameter Prompts

Prompt	Description
INP1	Process variable value of Input 1
OUT1*	Controller output in percent for Pen 1 control loop
SP1*	Setpoint for Pen 1 control loop
DEV1	Process variable deviation from Control 1 setpoint
XXXXXX	Totalizer value in lower display for Input 1 (PV in upper display)
INP2	Process variable value of Input 2
OUT2*	Controller output in percent for Pen 2 control loop
SP2*	Setpoint for Pen 2 control loop
DEV2	Process variable deviation from Control 2 setpoint
XXXXXX	Totalizer value in lower display for Input 2 (PV in upper display)

* You can press **▲** or **▼** to change the value of this parameter.

Continued on next page

5.5 Monitoring Your Recorder, Continued

Diagnostic error messages

The DR4200 EV runs background tests to verify data and memory integrity. If there is a malfunction, an error message will blink in the lower display. In the case of more than one simultaneous malfunctions, only the one with the highest priority will appear on the lower display.

A list of background error messages is contained in Table 5-9. If any of these error messages occur, refer to *Section 7 - Troubleshooting /Service* for information to correct the failure.

Table 5-9 Error Messages

Prompt	Description
EE FAIL	Unable to write to nonvolatile memory
FAILSF	Failsafe
INP FL	Two consecutive failures of input integration
INP RNG	Input out-of-range Linear: $\pm 10\%$ out-of-range Characterized: $\pm 1\%$ out-of-range

5.6 Operator Functions

Actions an operator can initiate

An operator can do the following:

- Change the Control Mode (Auto/Man)
- Adjust the Output Manually
- Change the Setpoint
- Check the Alarm Setpoints
- Reset the Totalizer
- Run a Key Test

Note that some actions depend upon how the recorder was configured and the features supplied on your particular recorder model.

Refer to the following pages for functions and procedures.

INP indicator

Remember, for recorders with two pens (both enabled) remember that any controller-related values displayed, including control mode, correspond with the lighted INP indicator.-- “1” means that the values apply for pen #1 and “2” means that the values apply for pen #2. Sequentially press the **DISP** key to scroll through the displays and light the appropriate INP indicator for controller-related values.

5.7 Operating Modes

Available modes

The recorder can operate in two basic modes:

- Manual
 - Automatic with Local Setpoint
-

Mode definitions

Table 5-10 lists the three modes and their definitions.

Table 5-10 Operating Mode Definitions

Operating Mode	Definition
MANUAL	When switched to manual mode, the recorder holds its output at the last value used during automatic operation and stops adjusting the output for changes in setpoint or process variable. Instead, you adjust the output by changing the value shown in the lower display. See <i>"Selecting Modes"</i> .
AUTOMATIC with LOCAL SETPOINT	In automatic local mode, the recorder operates from the local setpoint and automatically adjusts the output to maintain the setpoint at the desired value. In this mode you can adjust the setpoint. See <i>"Setpoints"</i> .











5.7 Operating Modes, Continued

Selecting manual or automatic mode

An alternate action switch places the recorder in automatic or manual mode of operation.

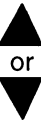
- Switching between manual and automatic will be bumpless, except when the PD+MR algorithm is selected.
- Table 5-11 includes procedures for selecting automatic or manual mode and changing the output while in manual.

Table 5-11 Procedure for Selecting Automatic or Manual Mode

Step	Operation	Press	Action/Result
1	Selecting automatic mode		<p>Until "A" indicator is ON. The recorder regulates its output to maintain the PV at the desired setpoint.</p> <p>Upper Display  shows the PV value</p> <p>Lower Display  shows INP and the selected Input (1 or 2).</p> <p>Press the  key to toggle between INP1 and INP2.</p>
2	Selecting manual mode		<p>Until "M" indicator is ON. The recorder holds its output at the last value used during automatic operation and stops adjusting the output for changes in setpoint or process variable.</p> <p>Upper Display  shows the output value in (%).</p> <p>Lower Display  shows OUT and the Pen # (1 or 2).</p> <ul style="list-style-type: none"> • If you get a "KEYERR" prompt, be sure output has been enabled and control has been selected as output type through configuration. See <i>Section 2 - Setup Tasks</i>.
3	Adjust the output in manual mode		<p>Adjust the output value while in manual mode.</p> <p>Upper Display  shows the output value in (%)</p> <p>Lower Display  shows OUT and the Pen # (1 or 2).</p>
4	Return to automatic mode		"A" indicator appears indicating automatic mode.

5.8 Changing the Control Setpoint







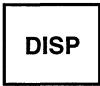
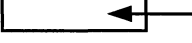
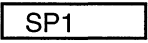

Introduction

The recorder can be setup for control on pen 1 and/or pen 2. See *Section 2 - Setup Tasks* for details.

Changes the control setpoint

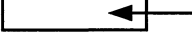
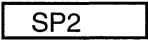
Follow the procedure in Table 5-12 to change the control setpoints.

Table 5-12 Changing the Control Setpoints

Step	Operation	Press	Action/Result
1	Select setpoint for pen 1 (or input 1)		until you see: Upper Display  Lower Display 
		 or 	to change the setpoint to the desired value.
2	Select setpoint for pen 2 (input 2)		Until "INP2" indicator lights.
			until you see: Upper Display  Lower Display 
		 or 	to change the setpoint to the desired value.
3	Return to input 1 parameters for display		to light "INP1" indicator

5.9 Alarm Setpoints







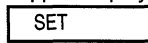

Introduction

- An alarm consists of a relay contact and an operator interface indication. The alarm relay is de-energized if Alarm Setpoint 1 or Setpoint 2 is exceeded.
- The alarm relay is energized when the monitored value goes into the allowed region by more than the hysteresis.
- There are four alarm setpoints, two for each alarm.
- The type and state (High or Low) is selected during configuration: see *Section 3 - Configuration* for details.

Procedure for displaying the alarm setpoints

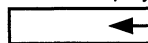
The procedure for displaying and changing the alarm setpoints is listed in Table 5-13.

Table 5-13 Procedure for Displaying or Changing the Alarm Setpoints

Step	Operation	Press	Action/Result
1	Access the Alarm Set Up group		Until you see: Upper Display  Lower Display 
2	Access the Alarm Setpoint Values		Until you display the desired alarm setpoint and its value. Their order of appearance is shown below. Upper Display  ← The alarm setpoint value Lower Display  A1S1 VA = (Alarm 1, Setpoint 1 value) A1S2 VA = (Alarm 1, Setpoint 2 value) A2S1 VA = (Alarm 2, Setpoint 1 value) A2S2 VA = (Alarm 2, Setpoint 2 value)
		 or 	Change any alarm setpoint value you select in the upper display.
3	Return to normal operation		Returns to normal operation.

5.10 Resetting the Totalizer Value

Introduction

If the totalizer is enabled and has been configured to allow resetting, you can reset the current totalizer value as follows.



- Refer to *Section 4- Configuration*, under Set-up prompt “TOTAL” to enable the totalizer function and allow the totalizer to be reset.
- Refer to the procedures that follow to:
 - reset the totalizer
 - display the totalizer value.

Resetting the totalizer

Follow the procedure in Table 5-14 to reset the totalizer value.

www.DataSheet4U.com

Table 5-14 Procedure for Resetting the Totalizer

Step	Operation	Press	Action/Result
1	Access the Totalizer Set Up group	SET UP	Until you see: Upper Display SET Lower Display TOTAL on 2-pen recorders be sure the correct input (1 or 2) is displayed.
2	Allow Totalizer Reset	FUNC once	You will see: Upper Display Ex XXX Lower Display (a Value)
		FUNC again	You will see: Upper Display NO Lower Display RESET
		 or 	Change NO to YES in the upper display.
3	Return to normal operation	DISP	Returns to normal operation.

Continued on next page

5.11 Changing Input Type and Restoring Factory or Field Calibration Values

Introduction

You can change the input type through hardware and software configuration to match another type sensor. You can also restore factory or field calibration for the selected input through software configuration.

ATTENTION The field calibration can only be restored if the selected input was previously calibrated in the field.

Procedure

Follow the procedure in Table 5-15 to change the input type.

ATTENTION You can use this procedure to quickly restore factory or field calibration for the present input actuation. Skip steps 1, 7 and 8; and repeat steps 5 and 6 to re-select the present input type and restore the applicable calibration constants.

Table 5-15 Changing Input Type and Restore Factory or Field Calibration Values











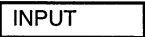

Step	Press	Action
1		Check the hardware configuration for the selected input type. See <i>Section 2 - Setup Tasks</i> .
2		to select the desired input (indicator INP1 or INP2)
3		Until you see: Upper Display  Lower Display 
4		Until you see: Upper Display  Present Input type (for example: J L) Lower Display 
5		until the desired input appears in the upper display.

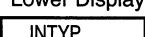
Table 5-15 continued on next page

5.11 Changing Input Type and Restoring Factory or Field Calibration Values, Continued

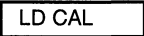
Procedure, continued Table 5-15 Changing Input Type and Restore Factory or Field Calibration Values, continued

Step	Press	Action
6		<p>You will see:</p> <p>Upper Display </p> <p>Lower Display </p> <p>This will restore the factory calibration.</p>
		<p>If the selected input was ever field calibrated.</p> <p>You will see</p> <p>Upper Display </p> <p>Lower Display </p> <p>This applies stored field calibration for the input.</p> <p>CAUTION Do not select “FLD” if the input type has never been field calibrated as outlined in <i>Section 6 - Calibration</i> in this manual.</p>
7		Check the other software and hardware configuration parameters for compatibility with the new input type, as applicable.
8		Be sure the correct sensor is connected to the input terminals and resume normal operation.

5.12 Maximizing Pen Life

Steps for maximizing pen life

Table 5-16 lists nine steps that will help to maximize the life of your chart pen.

Table 5-16 Maximizing Pen Life

Step	Action
1	Store the chart paper in a cool, clean dry place where the temperature does not exceed 40°C (104°F) and the humidity is below 65% RH.
2	Do not expose the pen tip and chart paper to abrasive chemicals or dust that cause excessive pen wear.
3	If the recorder is used in a dusty atmosphere, provide a positive 'clean air purge' to minimize dust particle accumulation on the chart paper.
4	Periodically clean the pen arm using a cotton swab dipped in alcohol. This is more important when the recorder is located in a dusty environment and no 'clean air purge' is used.
5	Never let the pen tip ride on the chart plate when the paper is not present. Use the pen lifter to raise the arm when changing the paper.
6	Keep the door closed while recording.
7	Always insert the pen arm tip into the shipping sponge when storing or shipping the recorder.
8	Be sure that the chart paper lays flat against the chart plate. Any ripple in the paper will cause light pen printing.
9	Be sure the chart hub assembly is pushed onto the motor shaft so that it is flush with the chart plate.

5.13 Routine Maintenance

Introduction

The DR4200 recorder does not require any periodic maintenance as such. You will, however, have to replace the chart and ink cartridges as required.

However, humidity can affect the size of the chart such that the pen is offset from the proper chart increment. See subsection 7.8 "Checking Electrical Pen Alignment at Span and Zero" to be sure that the pen and chart are aligned.

Replacing the ink cartridge

Refer to Figure 5-6 and follow the procedure in Table 5-17 to replace the ink cartridge.

Table 5-17 Replacing the Ink Cartridge

Step	Action
1	Remove the power from the recorder. Push in the button on the door and swing the door open.
2	Pull up on the pen lifter to raise the pen(s) from the chart plate.
CAUTION Be careful not to move the pen arm while removing and installing the ink cartridge.	
3	Unclip and remove the purple (Pen #1) or red (Pen #2) ink cartridge from the pen arm.
4	Remove the protective cap from the pen tip on the new cartridge and open its clip.
5	Slide the new cartridge onto the pen arm so that its tip fits into the notch at the end of the pen arm and close the clip to secure the cartridge to the pen arm.
6	Push down the pen lifter to return the pen tip to the chart.
7	Close the door and apply power.

Continued on next page

5.13 Routine Maintenance, Continued

Replacing the chart

Refer to Figure 5-5 and follow the procedure in Table 5-18 to replace the chart.

Table 5-18 Replacing the Chart

Step	Action
1	Push in the button on the door and swing the door open.
2	Pull up on the pen lifter to raise the pen(s) from the chart plate.
3	Lift the chart from the hub and locating pin and slide it from under the pen(s) to remove it from the chart plate.
4	Slip the new chart under the pen lifter, pens and time index; and press the chart into place over the chart hub and locating pin.
5	Grasp the chart hub and locating pin and turn the chart until the desired time line on the chart is aligned with the time index on the chart plate and Pen #1. Push down the lifter to return the pen(s) to the chart.
6	Close the door.

Figure 5-5 Replacing the Ink Cartridge and Chart.

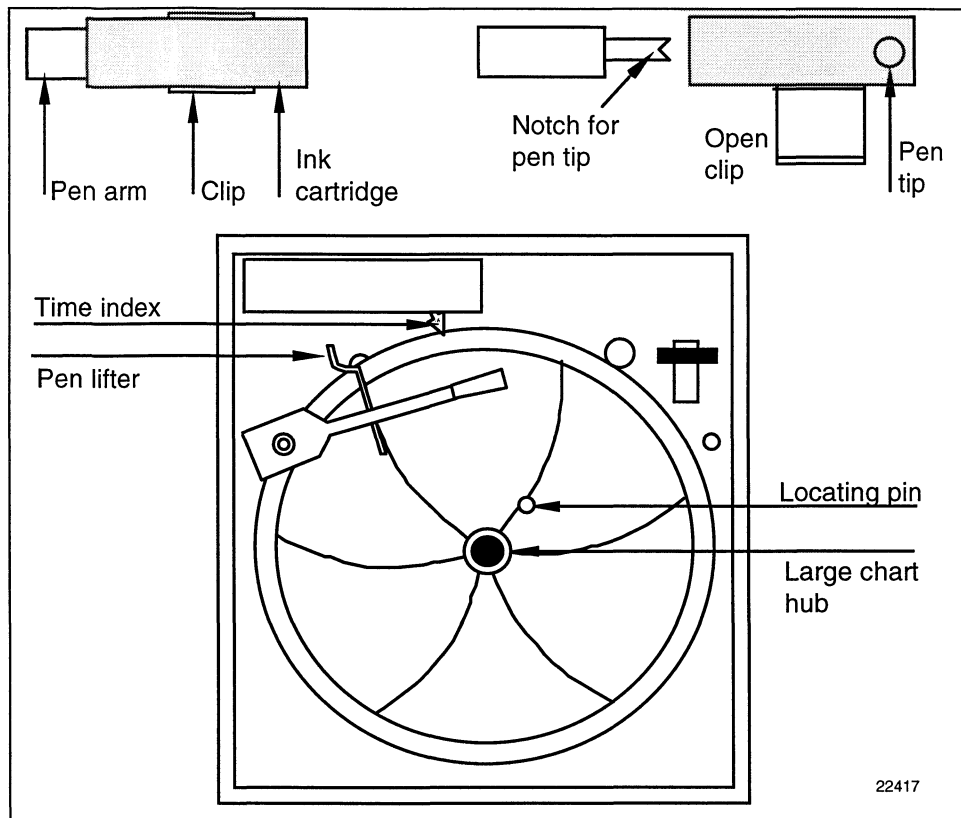

Section 6 – Calibration

6.1 Overview

Introduction

This section explains how to field calibrate an input as well as a 4-20 mA current output. Since the recorder stores both factory and field calibration constants in the memory, you can easily restore the factory calibration for any configurable input using the procedure given in subsection 5.11 in the operation section of this manual.

Also, you will be able to restore the field calibration for any input that is calibrated using the procedure in this section.

What's in this section?

This section contains the following topics:

	Topic	See Page
6.1	Overview	97
6.2	Input Calibration Minimum and Maximum Range Values	98
6.3	Input Calibration Preliminary Information	99
6.4	Input Calibration Set Up and Wiring	101
6.5	Input Calibration Procedure	105
6.6	Current Output Calibration	108



WARNING—SHOCK HAZARD



INPUT AND OUTPUT CALIBRATION MAY REQUIRE ACCESS TO HAZARDOUS LIVE CIRCUITS, AND SHOULD ONLY BE PERFORMED BY QUALIFIED SERVICE PERSONNEL. MORE THAN ONE SWITCH MAY BE REQUIRED TO DE-ENERGIZE UNIT BEFORE CALIBRATION.

6.2 Input Calibration Minimum and Maximum Range Values

Minimum and maximum range values

You should calibrate the recorder for the minimum (0%) and maximum (100%) range values of your particular sensor.

- If your recorder has two (pens) inputs, calibrate each input separately. Make sure the correct input is on display INP1 or INP2 use **[FUNC]** key to select. Select the voltage or resistance equivalent for 0% and 100% range values from Table 6-1, use these values when calibrating your recorder.

Table 6-1 Voltage and Resistance Equivalents for 0% and 100% Range Values

Sensor Type	PV Input Range		Range Values *		
	°F	°C	0%	68°F/20°C	100%
Thermocouples					
B	105 to 3300	41 to 1816	0 mV	0.003 mV	13.763 mV
E	-454 to 1832	-270 to 1000	-9.835 mV	1.192 mV	76.358 mV
E (low)	-200 to 1100	-129 to 593	-6.471 mV		44.547 mV
J	0 to 1600	-18 to 871	-0.885 mV	1.019 mV	50.059 mV
J (low)	20 to 770	-7 to 410	-0.334 mV		22.397 mV
K	-320 to 2500	-196 to 1371	-5.822 mV	0.798 mV	54.845 mV
K (low)	-20 to 1000	-29 to 538	-1.114 mV		22.251 mV
NiNiMoly	32 to 2500	0 to 1371	-0.001 mV	1.458 mV	71.330 mV
NIC Nicrosil Nisil	0 to 2372	-17.8 to 1300	-0.461 mV	0.525 mV	47.502 mV
R	0 to 3100	-18 to 1704	-0.089 mV	0.111 mV	20.275 mV
S	0 to 3100	-18 to 1704	-0.092 mV	0.113 mV	17.993 mV
T	-300 to 700	-184 to 371	-5.341 mV	0.789 mV	19.095 mV
T (low)	-200 to 600	-129 to 316	-4.149 mV		15.789 mV
W5W26	0 to 4200	-18 to 2315	-0.234 mV	0.062 mV	37.066 mV
RTD (IEC=0.00385)					
100 Ω **	-300 to 900	-184 to 482	25.18 Ω		274.96 Ω
100 Ω (low)**	-130 to 392	-90 to 200	64.30 Ω		175.84 Ω
100 Ω (T)***	-238 to 482	-150 to 250	38.79 Ω		195.57 Ω
Milliamps	4 to 20 mA		4 mA		20 mA
Millivolts	0 to 100 mV		0 mV		100 mV
	0 to 200 mV		0 mV		200 mV
Volts	0 to 1 Volt		0 Volt		1 Volts
	1 to 5 Volts		1 Volt		5 Volts
	0 to 5 Volts		0 Volt		5 Volts
	0 to 10 Volts **		0 Volts		10 Volts

* Range values for thermocouples are based on a cold junction temperature of 32°F (0°C). These values must be adjusted for the actual cold junction temperature when using the ambient temperature method for calibrating thermocouple inputs.

** IEC = 0.00385

*** IEC = 0.00391

6.3 Input Calibration Preliminary Information

Disconnect the field wiring

Depending on which input (#1 or #2) you are going to calibrate, tag and disconnect any field wiring connected to the input terminals on the input boards inside the recorder. Reference Figure 6-1 and follow the procedure in Table 6-2.

Table 6-2 Disconnect the Field Wiring

Step	Action
1	Remove the operating power from the recorder, open the door on the recorder, and swing the chart plate out.
2	Depending on the input (1 or 2) you are going to calibrate, disconnect the input connections from terminal block TB3 on the bottom edge of the applicable circuit board. See Figure 6-1 for the location of the circuit boards and input connectors.

Figure 6-1 Location of the Input Connections on the Input Boards

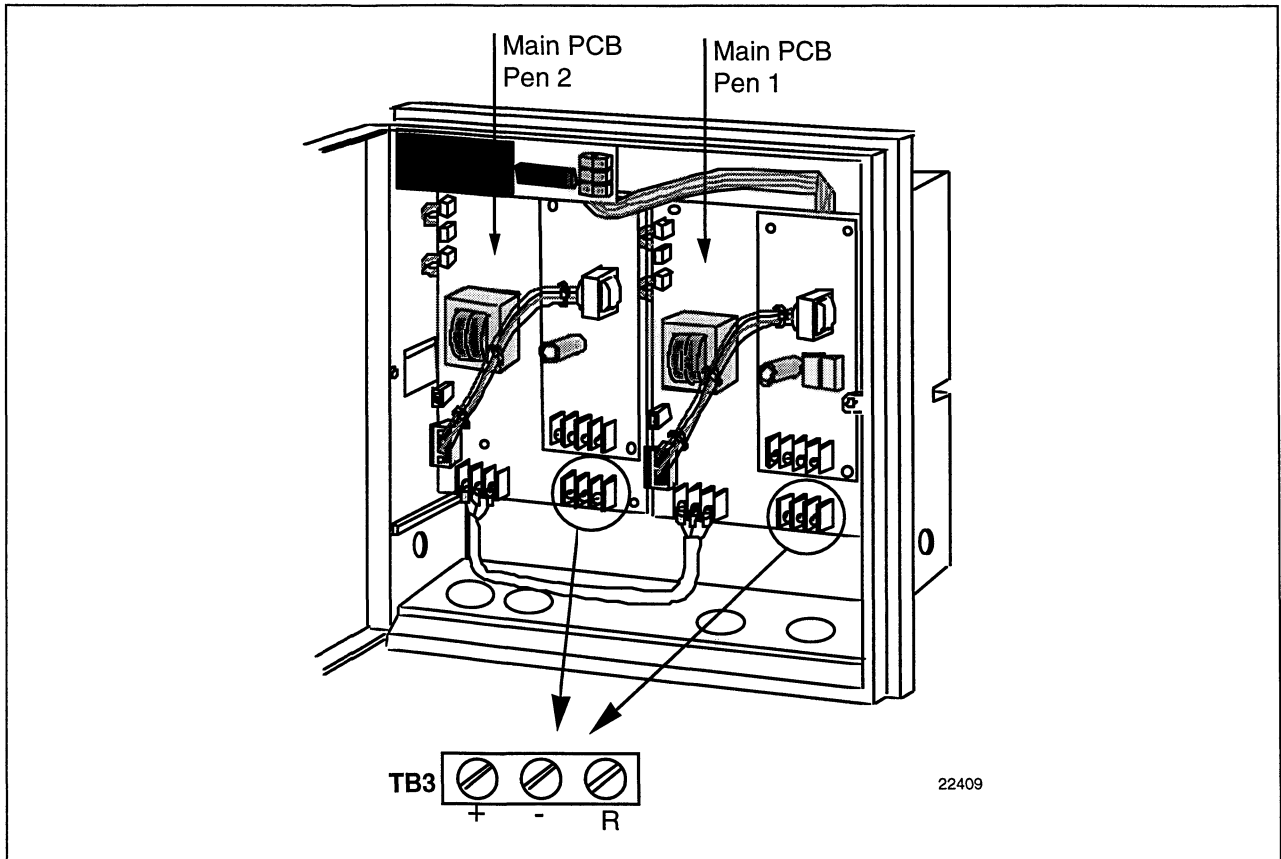

Continued on next page

6.3 Input Calibration Preliminary Information, Continued

Equipment needed

Table 6-3 lists the equipment required to calibrate the specific types of inputs listed in the table. You will need a medium size bladed screwdriver for general use and a small size bladed screwdriver for use with the screws on the connector plugs.

Table 6-3 Equipment Needed

Type of Input	Equipment Needed
<i>Thermocouple Inputs (Ice Bath)</i>	<ul style="list-style-type: none"> • A calibrating device with $\pm 0.02\%$ accuracy for use as a signal source such as a millivolt source. • Thermocouple extension wire that corresponds with the type of thermocouple that will be used with the recorder input. • Two insulated copper leads for connecting the thermocouple extension wire from the ice baths to the precision calibrator. • Two containers of crushed ice.
<i>RTD (Resistance Thermometer Device)</i>	<ul style="list-style-type: none"> • A resistance decade box, with $\pm 0.02\%$ accuracy, capable of providing stepped resistance values over a minimum range of 0 to 1400 Ohms with a resolution of 0.01 ohm. • Three insulated copper leads for connecting the decade box to the recorder.
<i>Milliampere, Millivolt, and Volts Inputs</i>	<ul style="list-style-type: none"> • A calibrating device with $\pm 0.02\%$ accuracy for use as a signal source. • Two insulated copper leads for connecting the calibrator to the recorder.

6.4 Input Calibration Set Up and Wiring

Jumper positions and DIP switch settings

Before starting the calibration activity, check that the jumpers and DIP switch settings on the applicable Main PCB (pen 1 or pen 2) are set in the proper positions for the particular sensor being calibrated.

Refer to subsection 2.2 - *Configuration Selections for Recording* in Section 2 - *Set Up Tasks*.

General set up procedure

Table 6-4 lists the general set up procedure for all methods of calibration. Do this procedure and then refer to the set up procedure and diagram for your specific input.

Table 6-4 General Set Up Procedure

Step	Action
1	Set-up and connect the calibrator to the input plug for the applicable input circuit board in your recorder according to the particular input sensor being used. Refer to the following figures for corresponding set-up diagrams: <ul style="list-style-type: none">• Figure 6-2 Thermocouple inputs using an ice bath• Figure 6-3 RTD (Resistance Thermometer Device) inputs.• Figure 6-4 mA and Volts.
2	Route leads (for example: copper leads or thermocouple extension wires) through a conduit hole in the recorder case so that you will be able to close the chart plate.
3	Close the chart plate after you have completed the applicable calibration set up.

Continued on next page

6.4 Input Calibration Set Up and Wiring, Continued

Thermocouple inputs using an ice bath

Refer to Figure 6-2 and wire the recorder according to the procedure given in Table 6-5.

Table 6-5 Set Up Wiring Procedure for Thermocouple Inputs Using an Ice Bath

Step	Action
1	Connect the copper leads to the calibration source (see Figure 6-2).
2	Connect a length of thermocouple extension wire to the end of each copper lead and insert the junction points into the ice bath.
3	Connect the other end of the thermocouple extension wires to the terminals on the Main PCB for the applicable input connector (TB3).

www.DataSheet4U.com

Figure 6-2 Calibration Set Up Diagram for Thermocouple Inputs Using an Ice Bath

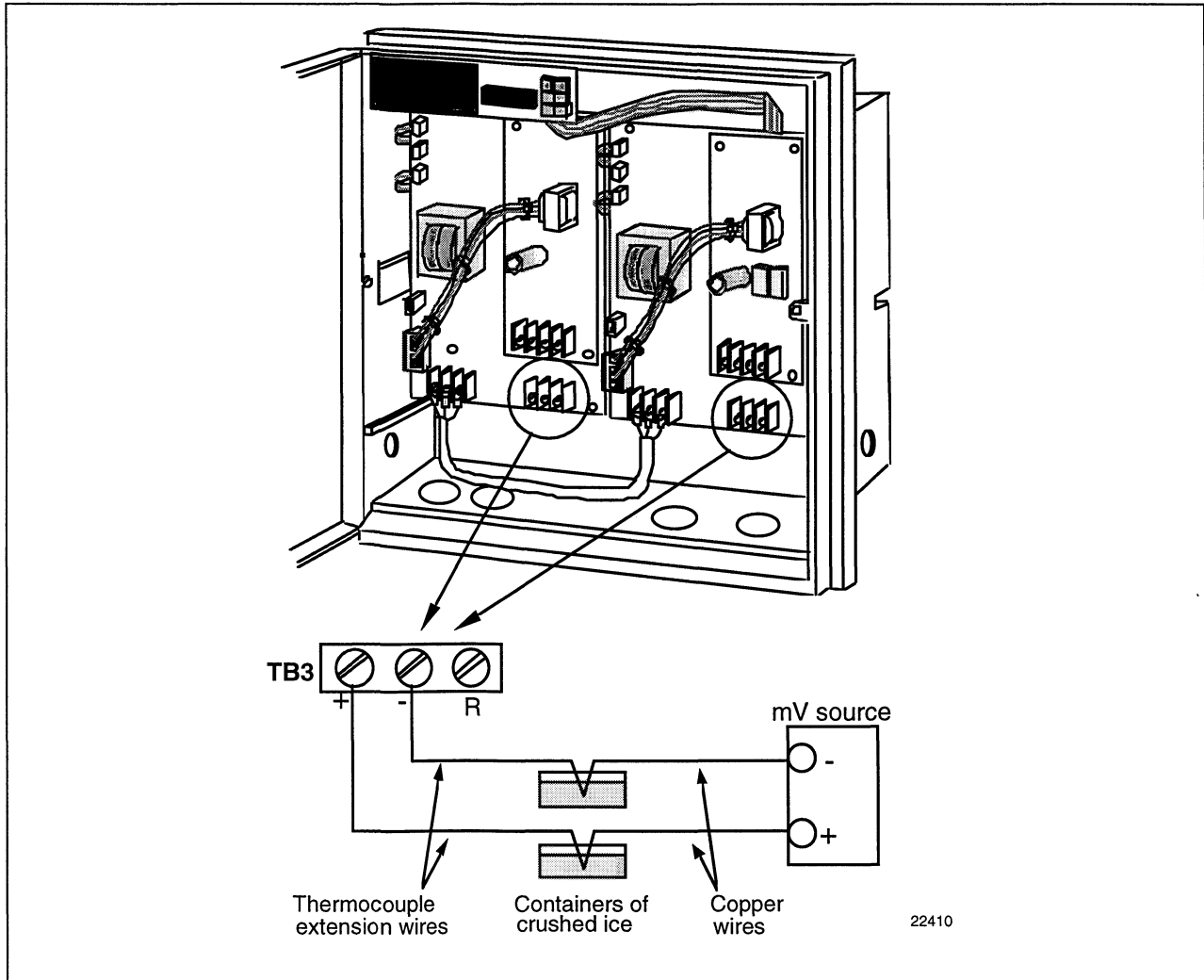

Continued on next page

6.4 Input Calibration Set Up and Wiring, Continued

RTD (Resistance Thermometer Device) inputs

Refer to Figure 6-3 and wire the recorder according to the procedure given in Table 6-6.

Table 6-6 Set Up Wiring Procedure for RTD Inputs

Step	Action
1	Connect the copper wire to the calibration source (see Figure 6-3).
2	Connect the other end of the copper wire to the terminals on the Main PCB for the applicable input connector (TB3).

Figure 6-3 Calibration Set Up Diagram for RTD Inputs

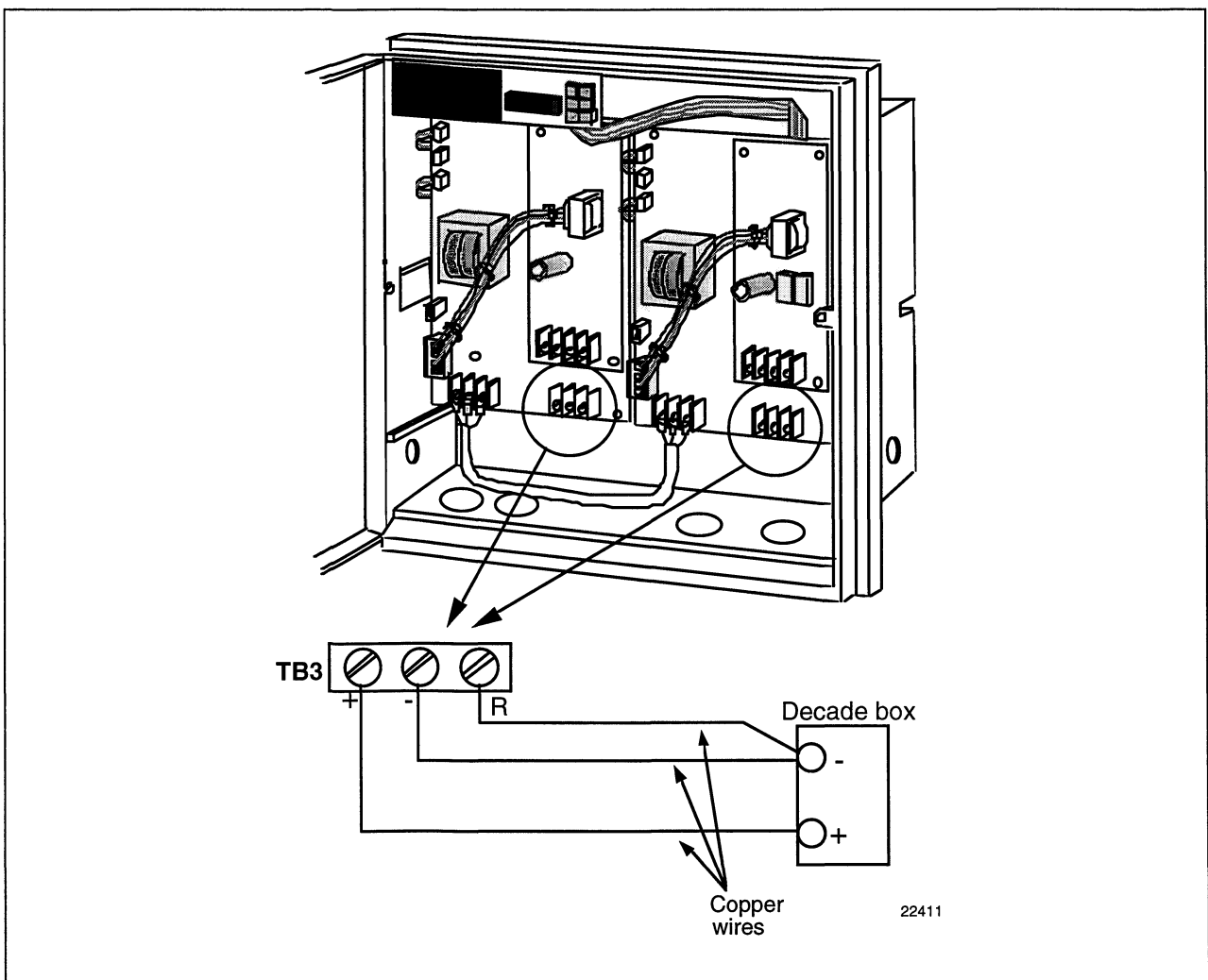

Continued on next page

6.4 Input Calibration Set Up and Wiring, Continued

Millivolts, Volts and Milliamp inputs

Refer to Figure 6-4 and wire the recorder according to the procedure given in Table 6-7.

Table 6-7 Set Up Wiring Procedure for Millivolts, Volts, and Milliamps Inputs

Step	Action
1	Connect the copper wire to the calibration source (see Figure 6-4).
2	Connect the other end of the copper wire to the terminals on the Main PCB for the applicable input connector (TB3).

www.DataSheet4U.com

Figure 6-4 Calibration Set Up Diagram for Millivolts, Volts, and Milliamps Inputs

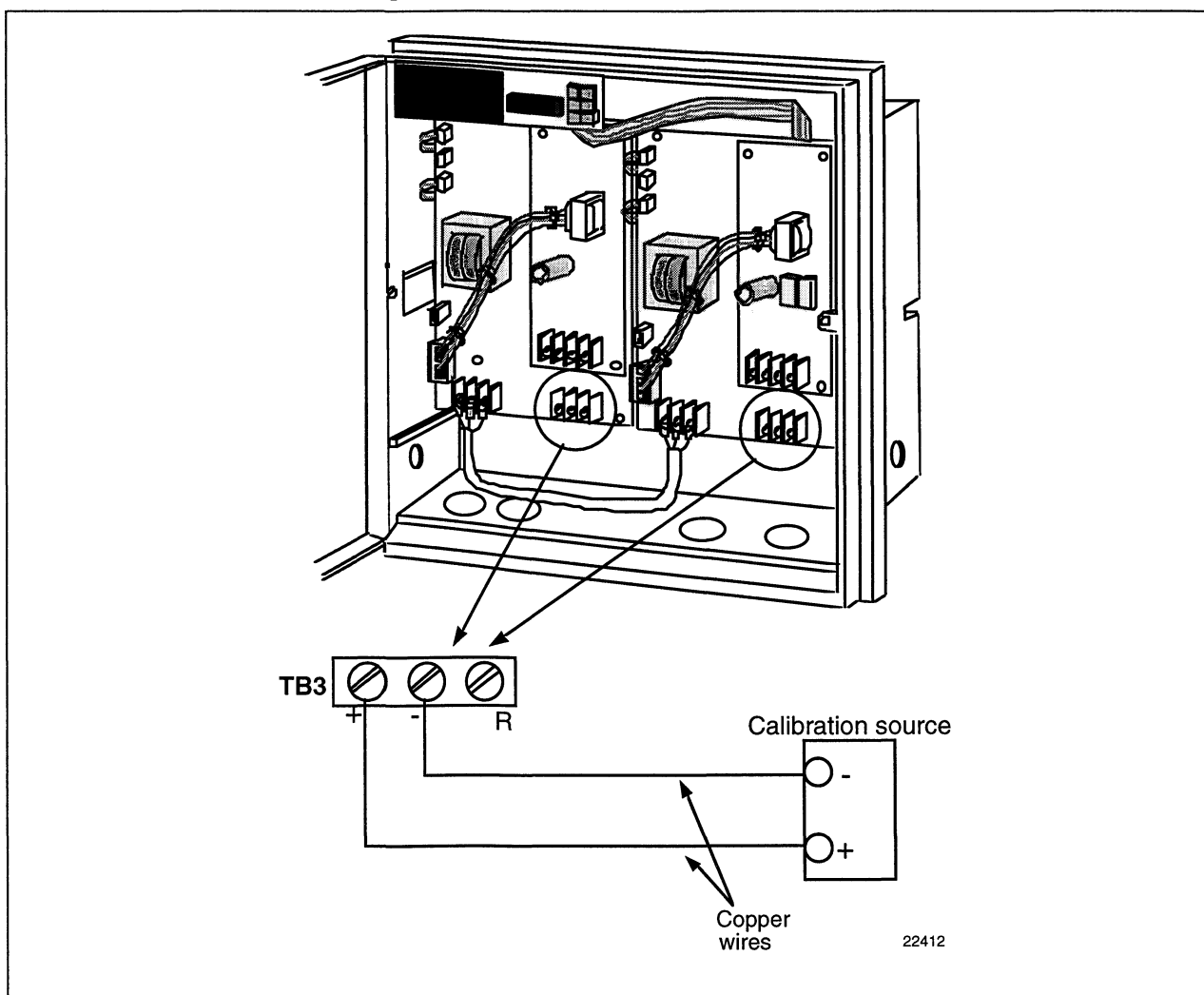

Continued on next page

6.5 Input Calibration Procedure

Introduction

Apply power and allow the recorder to warm up for 30 minutes before you calibrate.

- Please read “Set Up and Wiring” before beginning the procedure.
- Make sure you have “LOCK” set to “NONE” (see Section 4– Configuration).
- The calibration procedure for inputs #1 and #2 are identical. The displays indicate the input number. Press **FUNC** key to change display as required (INP1 or INP2).

CAUTION For *Milliampere inputs*, be sure the current source is at zero before switching on the calibrator. Do not switch the calibrator on/off while it is connected to the recorder’s input.

ATTENTION For *linear inputs*, avoid step changes in input signal. Vary calibration source signal smoothly from initial value to final 100% value.

Calibration procedure sequence The calibration procedure sequence for all inputs is listed in Table 6-8.

Table 6-8 Input Calibration Procedure Sequence







Step	Description	Press	Action/Result
1	Enter Calibration Mode	 until you see	Upper Display  Lower Display  ATTENTION If “CAL” doesn’t appear or prompt access is declined, check “LOCK” configuration.
			You will see: Upper Display  Lower Display 
			The calibration sequence is enabled and you will see: Upper Display  Lower Display 

Table 6-8 is continued on next page

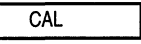
6.5 Input Calibration Procedure, Continued

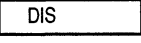
Table 6-8 Input Calibration Procedure Sequence, continued

Step	Description	Press	Action/Result						
2	Calibrate 0%	<div style="border: 1px solid black; padding: 2px; width: fit-content; margin: 0 auto;">FUNC</div>	<p>You will see:</p> <p>Upper Display</p> <div style="border: 1px solid black; padding: 2px; width: fit-content; margin: 0 auto;">APLY</div> <p>Lower Display</p> <div style="border: 1px solid black; padding: 2px; width: fit-content; margin: 0 auto;">INZERO</div> <ul style="list-style-type: none"> Adjust your calibration device to an output signal equal to the 0% range value for your particular input sensor, see Table 6-1 for Voltage or Resistance equivalents. Wait 30 seconds, then go to the next step. 						
3	Calibrate 100 %	<div style="border: 1px solid black; padding: 2px; width: fit-content; margin: 0 auto;">FUNC</div>	<p>You will see:</p> <p>Upper Display</p> <div style="border: 1px solid black; padding: 2px; width: fit-content; margin: 0 auto;">APLY</div> <p>Lower Display</p> <div style="border: 1px solid black; padding: 2px; width: fit-content; margin: 0 auto;">INSPAN</div> <p>Adjust your calibration device to an output signal equal to the 100% range value for your particular input sensor, see Table 6-1 for voltage or resistance equivalents, wait 30 seconds, and</p> <table border="1" style="width: 100%; border-collapse: collapse;"> <thead> <tr> <th style="width: 50%;">If...</th> <th style="width: 50%;">Then...</th> </tr> </thead> <tbody> <tr> <td>you are calibrating a thermocouple input</td> <td>Go to step 4</td> </tr> <tr> <td>you are calibrating other than a thermocouple input</td> <td>Go to step 5</td> </tr> </tbody> </table>	If...	Then...	you are calibrating a thermocouple input	Go to step 4	you are calibrating other than a thermocouple input	Go to step 5
If...	Then...								
you are calibrating a thermocouple input	Go to step 4								
you are calibrating other than a thermocouple input	Go to step 5								

Table 6-8 is continued on next page

6.5 Input Calibration Procedure, Continued

Table 6-8 Input Calibration Procedure Sequence, continued

Step	Description	Press	Action/Result
4	<p>Check the Cold Junction Temperature</p> <p>CAUTION The accuracy of the recorder is directly affected by the accuracy of this value. Change this value only if the zero and span calibration procedures did not bring the recorder within the specified accuracy requirements.</p>	<div style="border: 1px solid black; padding: 5px; width: fit-content; margin: auto;">FUNC</div>	<p>The calculations for zero and span are now stored and you will see:</p> <div style="display: flex; align-items: center; margin-bottom: 10px;"> <div style="margin-right: 10px;">Upper Display</div> <div style="border: 1px solid black; padding: 2px 10px; display: inline-block;"> <div style="border-bottom: 1px solid black; width: 80%; margin-bottom: 2px;"></div> <div style="border-top: 1px solid black; width: 80%; margin-top: 2px;"></div> </div> <div style="margin-left: 10px;">←</div> <div style="margin-left: 10px;">The cold junction temperature at the rear terminals</div> </div> <div style="display: flex; align-items: center; margin-bottom: 10px;"> <div style="margin-right: 10px;">Lower Display</div> <div style="border: 1px solid black; padding: 2px 10px; display: inline-block;">C-J TEMP</div> </div> <ul style="list-style-type: none"> • The value in the upper display is the current reading of the temperature as measured at the thermocouple terminals (that is, at TB3) and recognized by the recorder. • When using the Ice Bath method, this value should be the terminal ambient temperature. <ul style="list-style-type: none"> – You can change this value, if it is in error, using the ▲ or ▼ key.
5	Exit the Calibration Mode	<div style="border: 1px solid black; padding: 5px; width: fit-content; margin: auto;">FUNC</div>	<p>The recorder stores the calibration constants and exit calibration mode. Repeat this procedure for the other pen, if required.</p>

6.6 Current Proportional Output Calibration

Introduction

Calibrate the recorder so that the output provides the proper amount of current over the desired range.

- The recorder can provide an output current range of from 0 to 20 milliamperes and can be calibrated at 4 mA for 0% of output and 20 mA for 100% of output or any other values between 0 and 20 mA.

Equipment needed

You will need a standard shop type milliammeter, with whatever accuracy is required, capable of measuring 0 to 20 milliamps.

Calibrator connections

Refer to Figure 6-5 and wire the recorder according to the procedure given in Table 6-9.

Table 6-9 Set Up Wiring Procedure Current Proportional Output

Step	Action
1	With the power off, door open, and the chart plate swung out; tag and disconnect field wiring from RLY1 terminal on terminal block TB1 on output PCB for pen 1 or pen 2 as applicable (see Figure 6-4).
2	Observing polarity, connect a milliammeter's leads to RLY1 terminals.
3	Close the chart plate; apply power and allow the recorder to warm up 15 minutes before you calibrate.

Figure 6-5 Test Equipment Connections for Calibrating Current Output

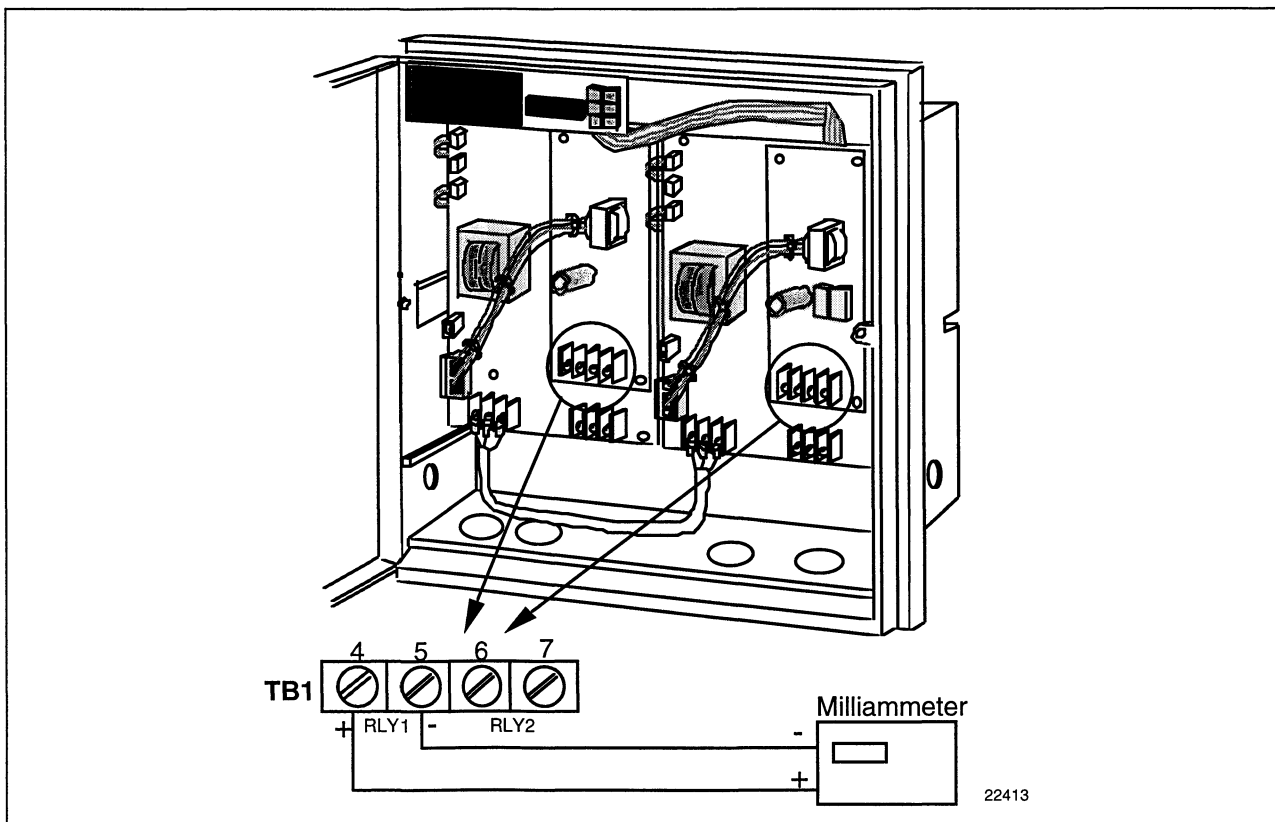







Continued on next page

6.6 Current Proportional Output Calibration, Continued

Procedure

The procedure for calibrating the Current Proportional Output is listed in Table 6-10. Make sure "LOCK" in the Set Up group is set to "NONE." For display recorders with 2 pens, be sure the correct input is - INP1 or INP2 indicator lit. Press **FUNC** key to change input on display to agree with the control loop output to be calibrated. See *Section 4 – Configuration*.

Table 6-10 Current Proportional Output Calibration Procedure

Step	Description	Press	Action/Result
1	Enter Calibration Mode	SET UP until you see	Upper Display CAL Lower Display CURENT ATTENTION If "CAL" doesn't appear or prompt across is denied, check the "LOCK" configuration. See <i>Section 4 - Configuration</i> .
2	Calibrate 0%	FUNC	You will see: Upper Display  a value (approx. 730) Lower Display ZERO
		 or 	Until the desired 0% output is read on the milliammeter. Use the values shown below depending on the action of your recorder. 4 mA For 4 to 20 mA Direct Action 20 mA For 4 to 20 mA Reverse Action
3	Calibrate 100%	FUNC	Stores the 0% value and, you will see: Upper Display  a value (approx. 3600) Lower Display SPAN
		 or 	Until the desired 100% output is read on the milliammeter. Use the values shown below depending on the action of your recorder. 20 mA For 4 to 20 mA Direct Action 4 mA For 4 to 20 mA Reverse Action
4	Exit the Calibration Mode	FUNC	The recorder stores the span value. Repeat procedure for control loop on other pen. Remove power from recorder and disconnect the milliammeter and connect output wiring.
		DISP or SET UP	To exit the calibration mode.

Section 7 – Troubleshooting / Service

7.1 Overview

Introduction

This section explains how to troubleshoot the DR4200EV recorder using self-diagnostic test results and error messages as well as some visual failure symptoms.

- Using an optimum replacement unit repair philosophy, trouble is traced to a printed circuit board(PCB)/hardware assembly level rather than to an individual PCB/hardware assembly component.
- While troubleshooting is straightforward, we recommend that only trained service technicians repair the recorder.

What's in this section?

The following topics are covered in this section.

	Topic	See Page
7.1	Overview	111
7.2	Troubleshooting Aids	113
7.3	Self Diagnostics	115
7.4	Visual Failure Symptoms	119
7.5	Troubleshooting Procedures	120
7.6	Parts Replacement Procedures	126
7.7	Checking Mechanical Pen Alignment at Zero	132
7.8	Checking the Electrical Pen Alignment at Span and Zero	133



WARNING—SHOCK HAZARD



TROUBLESHOOTING MAY REQUIRE ACCESS TO HAZARDOUS LIVE CIRCUITS, AND SHOULD ONLY BE PERFORMED BY QUALIFIED SERVICE PERSONNEL. MORE THAN ONE SWITCH MAY BE REQUIRED TO DE-ENERGIZE UNIT BEFORE SERVICING.

Continued on next page

7.1 Overview, Continued

Types of problems

Instrument performance can be adversely affected by installation and application problems as well as hardware problems. We recommend that you investigate the problems in the following order:

- Installation related problems
- Application related problems
- Hardware and software related problems

and use the information presented in this section to solve them.

- If a replacement of any part is required, follow the procedures in subsection 7.6 *Parts Replacement Procedures*.
-

Installation related problems

Read the Installation section in this manual to make sure the DR4200EV has been properly installed. The installation section provides information on protection against electrical noise, connecting external equipment to the recorder, and shielding and routing external wiring.

ATTENTION System noise induced into the recorder will result in diagnostic error messages recurring. If the diagnostic error messages can be cleared, it indicates a “soft” failure and is probably noise related.

If system noise is suspected, completely isolate the recorder from all field wiring. Use calibration sources to simulate PV and check all recorder and control functions; that is, Pen functions, Chart Trace, Gain, Rate, Reset, Output, Alarms, etc.

Application related problems

Review the application of the recorder; then, if necessary, direct your questions to the local sales office.

Hardware and software related problems

Use the troubleshooting error message prompts and recorder failure symptoms to identify typical failures which may occur in the recorder. Follow the troubleshooting procedures to correct them.

7.2 Troubleshooting Aids

Self diagnostics

The DR4200EV recorder runs self-diagnostic tests to monitor the recorder's general health. The tests are divided into three main groups and will produce an error message when failed.

An error message can occur

- at power-up - run when power is cycled off and on,
- during continuous background tests while in normal operation, and
- when the Status Tests are requested by the operator.

Table 7-4 lists all the error message prompts that you could see, the reason for the failure, and how to correct the problem.

Visual failure symptoms

Other failures may occur that deal with the power, pen functions, chart rotation, output, or alarms. Refer to the visual failure symptom in Table 7-6 to determine what is wrong and the troubleshooting procedures to use to correct the problem.

Check Installation

If a set of symptoms still persists, refer to *Section 2 - Setup Tasks* and *Section 3 - Installation* and ensure proper installation and proper use of the recorder in the system.



Continued on next page

7.2 Troubleshooting Aids, Continued

Determining the software version

Table 7-1 lists the procedure for identifying the software version number.

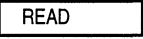
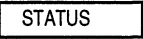
Table 7-1 Procedure for Identifying the Software Version

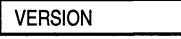
Step	Operation	Press	Action/Result
1	Select STATUS Set Up Group		Until you see: Upper Display  Lower Display 
2	Read the software version		Until you see: Upper Display  ← Software version Number Lower Display  Please give this number to the Customer Support person. It will indicate which version of DR4200EV you have and help them determine a solution to your problem.

Troubleshooting

The troubleshooting procedures are divided into two parts:

- Self Diagnostics - Error Message Prompts, and
- Visual Failure Symptoms.

If a “Failed” indication is given for one of the power-up tests and/or an error message prompt blinks in the lower display, refer to the Self Diagnostic error message prompts.

If erratic operation is observed, refer to the Visual Failure symptoms.

In either case, run the status tests to verify the status of the recorder’s basic self-diagnostic tests.

7.3 Self Diagnostics

Power-up tests

When the recorder is powered-up, four tests are run by the DR4200EV software to ensure memory integrity.

- As the tests are run, the displays appear as shown in Table 7-2.

Table 7-2 Power-up Tests

Lower Display	Upper Display
RAM TEST	PASS or FAIL
CONFTEST (configuration checksum)	PASS or FAIL
CAL TEST (working calibration)	PASS or FAIL
BATTERY (Only units with Totalizer option)	PASS or FAIL

Failsafe

If any of these four tests fail, "FAIL" appears momentarily in the upper display, then a display test is run, after which the controller goes into manual mode and you will see:

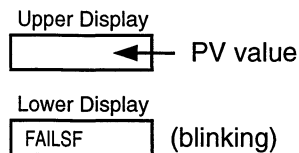

Refer to "Status Tests" (next page) to determine which tests have failed and how to correct them.

Continued on next page

7.3 Self Diagnostics, Continued

Status tests

When required, the results of the power-up tests can be checked to determine the reason the recorder has gone to "Failsafe".

The procedure in Table 7-3 tells you how to display the results of the status tests. Table 7-4 lists the tests, the reason for the failure, and how to correct the problem.

Table 7-3 Procedure for Displaying the Status Tests Results

Step	Operation	Press	Action/Result
1	Select STATUS Set Up Group	SET UP	Until you see: Upper Display <input type="text" value="READ"/> Lower Display <input type="text" value="STATUS"/>
2	Read the status tests results	FUNC	Until you see: Upper Display <input type="text" value="NO or YES"/> YES indicates a failure Lower Display <input type="text" value="FAILSF"/> <ul style="list-style-type: none"> Successive presses of the FUNC key will display the results of the status tests (PASS or FAIL) in the following order: RAM TEST CONF TEST CAL TEST BATTERY Identify the problem and correct the failure as shown in Table 7-5.

Continued on next page

7.3 Self Diagnostics, Continued

Error message prompts

The messages listed in Table 7-4 may appear during the power-up test or status test, or they may blink in the lower display as the result of ongoing background tests that verify data and memory integrity.

In the case of more than one simultaneous malfunction in the background tests, only the one with the highest priority will appear in the lower display.

Table 7-4 lists the error message, the test group that prompted the message, the reason for the failure, and how to correct the problem.

Table 7-4 Error Message Prompts

Lower Display Indication	Test Group	Reason For Failure	How to Correct the Problem
FAILSF	Status	This error message shows whenever the recorder goes into a failsafe mode of operation. This will happen if: <ul style="list-style-type: none"> • RAM test failed • Configuration test failed • Calibration test failed • Burnout configured for none and the input failed. 	<ol style="list-style-type: none"> 1. Check the operation of the input sensor. 2. Run through STATUS check to determine the reason for the failure. <ul style="list-style-type: none"> • Press the SET UP key until STATUS appears in the lower display. • Press the FUNC key to see what tests pass or fail, then run through the STATUS codes a second time to see if the error cleared. • Correct according to the recommendations given in this table.
RAMTST	Power-up or Status	RAM Failure	<ol style="list-style-type: none"> 1. Power cycle to see if the error clears. 2. If error doesn't clear, replace the main printed circuit board.
CFGTST	Power-up or Status	Configuration data is in error.	<ol style="list-style-type: none"> 1. Check all configuration prompts for accuracy. <ul style="list-style-type: none"> • See <i>Section 4 - Configuration</i> 2. Step through STATUS tests – the recorder will recalculate the checksum.
CALTST	Power-up or Status	The working calibration constants in the recorder are in error.	<ol style="list-style-type: none"> 1. If the recorder has not been field calibrated, refer to <i>subsection 5.11</i> in the operation section to restore factory calibration. 2. If the recorder has been field calibrated, refer to <i>subsection 5.11</i> in the operation section to restore field calibration.

Table 7-4 is continued on next page

7.3 Self Diagnostics, Continued

Error message prompts, continued

Table 7-4 Error Message Prompts, continued

Lower Display Indication	Test Group	Reason For Failure	How to Correct the Problem
EE FAIL	Background	Unable to write to nonvolatile memory. Anytime you change a parameter and it is not accepted, you will see EE FAIL.	<ol style="list-style-type: none"> 1. Check the accuracy of the parameter and reenter. 2. Try to change something in configuration. 3. Run through STATUS tests to rewrite to EEPROM.
INPFL	Background	Two consecutive failures of input 1 integration (for example, cannot make analog to digital conversion.)	<ol style="list-style-type: none"> 1. Be sure the range and actuation are configured correctly. 2. Check the input source. 3. See <i>Section 4 - Configuration</i> and change the input to a different type. Enter it, loop through the status tests, then return the input type to the original one. 4. Recalibrate if step 3 is unsatisfactory. Refer to <i>Section 6 - Input Calibration</i>. 5. Replace the Main printed circuit board.
BATTERY	Power-up or Background	Battery failure.	<ol style="list-style-type: none"> 1. Remove power. 2. Replace U12. 3. Recalibrate the recorder.
INPRNG	Background	<p>Input out of range. The process input is outside the range limits.</p> <p>If you have a linear input and the range goes outside the range limits, the recorder switches to manual mode at the configured Failsafe output value.</p>	<ol style="list-style-type: none"> 1. Make sure the range and actuation are configured properly. 2. Check the input source. 3. See subsection 5.11 in the Operation Section to restore the factory or field calibration, as applicable. 4. Field calibrate. See <i>Section 6 - Input Calibration</i>. 5. Replace the Main printed circuit board.

Table 7-4 is continued on next page

7.4 Visual Failure Symptoms

Introduction

In addition to the error message prompts, there are visual failure symptoms that can be identified by noting the erratic recorder functions.

Symptoms

Compare your symptoms with those shown in Table 7-5 and refer to the troubleshooting procedure indicated to correct the problem.

Table 7-5 Visual Failure Symptoms

Symptom	Trouble-shooting Procedure
Recorder will not operate	1
Recorder operation is normal but pen trace is incorrect	2
Chart rotates at wrong speed or will not rotate (pen indication correct)	3
Pen remains at high end of range when input signal is low	4
A key does not respond and/or a display does not light	5
Displayed output does not agree with controller output	
Current Proportional Output Type	6
Single or Dual Relay Output Type	7
External Alarm Function does not operate properly	8

7.5 Troubleshooting Procedures

Introduction

The troubleshooting procedures for the Visual Failure Symptoms are listed in numerical order as they appear in Table 7-5. Each procedure lists what to do if you have that particular failure and how to do it or where to find the data needed to accomplish the task. Progressive steps provide aid in finding and fixing the problem.

Equipment needed

You will need the following equipment in order to troubleshoot the symptoms listed in the tables that follow:

- DC Milliammeter – mAdc
- Calibration sources – T/c, mV, Volt, etc.
- Voltmeter

Procedure #1

Table 7-6 explains how to troubleshoot recorder failure symptoms.

Table 7-6 Troubleshooting Recorder Failure Symptoms

Step	What to do	How to do it or where to find the data
1	Check the fuse (F1) on the main printed circuit board. (located below the transformer)	Replace if defective.
2	Check the supply voltage.	Measure the line voltage across connections on the Main printed circuit board for Pen 1.
3	Check the connections to TB1 on the main printed circuit board.	Refer to <i>subsection 3.5 - AC Wiring Procedures</i> .
4	Check the system for brown-outs, heavy load switching, etc.; and conformance to installation instructions.	Refer to <i>Section 3 - Installation</i> .
5	Replace the main printed circuit board.	Refer to the replacement procedures in this section.

Continued on next page

7.5 Troubleshooting Procedures, Continued

Procedure #2

Table 7-7 explains how to troubleshoot a pen trace problem.

Table 7-7 Troubleshooting Pen Trace Failure Symptoms

Step	What to do	How to do it or where to find the data
1	Check the ink cartridge for proper installation.	Reposition or replace the ink cartridge, if the pen arm is severely warped, replace the pen arm.
2	Check that the chart agrees with the actuation type and chart setup.	Replace wrong chart with correct chart. Refer to <i>Section 2 - Setup Tasks</i> .
3	Check the pen alignment	Follow the procedure in Subsection 7.8
4	Check the sensor for the proper type and its ability to function.	Verify the input configuration data and operation of the sensor.
5	Recalibrate the recorder.	Refer to <i>Section 6 - Input Calibration</i> . For thermocouple input, be sure to confirm cold-junction temperature calibration.
6	Replace the servo plate assembly.	Refer to the replacement procedure in this section.
7	Replace the Main printed circuit board.	Refer to the replacement procedure in this section.

Procedure #3

Table 7-8 explains how to troubleshoot a chart rotation problem.

Table 7-8 Troubleshooting Chart Rotation Failure Symptoms

Step	What to do	How to do it or where to find the data
1	Check the chart installation.	Be sure the drive pin on the hub is in the drive hole on the chart.
2	Check the configured chart speed value and change it, if required.	Refer to <i>Section 2- Setup Tasks</i> .
3	Check the motor cable plug connection at connector J3 on the Main printed circuit board for Pen 1.	Power down the recorder and visually examine the plug and reseal it.
4	Replace the chart motor.	Refer to the replacement procedure in this section.
5	Replace the Main printed circuit board.	Refer to the replacement procedure in this section.

Continued on next page

7.5 Troubleshooting Procedures, Continued

Procedure #4

Table 7-9 explains what to do if the pen remains at the high end of range when the input signal is low.

Table 7-9 Troubleshooting Erratic Pen Movement Symptoms

Step	What to do	How to do it or where to find the data
1	Check the sensor and lead wires for continuity. Check the connections to TB3 on Main printed circuit board.	Replace the sensor lead wires as needed. Tighten the connections.
2	Check the pen and input configuration data.	Refer to <i>Section 2 - Setup Tasks</i> and <i>Section 4 - Configuration</i> .
3	Run self test.	Refer to subsection 5.3.
4	Replace the servo plate assembly.	Refer to the replacement procedure in this section.
5	Replace the main printed circuit board.	Refer to the replacement procedure in this section.

Continued on next page

7.5 Troubleshooting Procedures, Continued

Procedure #5

Table 7-10 explains what to do if a key does not respond and/or a display does not light.

Table 7-10 Troubleshooting Keyboard and/or Display Failure Symptoms

Step	What to do	How to do it or where to find the data
1	Run a Key Test to check the operation of the keys and displays.	Refer to <i>subsection 5.3 Operations</i> for procedures on running a key test.
2	Replace the switch (keyboard) and display printed circuit board as required.	Refer to the replacement procedure in this section.

Procedure #6

Table 7-11 explains what to do if the displayed output does not agree with the Current Proportional control output.

Table 7-11 Troubleshooting Current Proportional Output Failure Symptoms

Step	What to do	How to do it or where to find the data
1	Be sure the recorder is configured for current output.	Refer to <i>Section 2 - Setup Tasks</i> and <i>Section 4 - Configuration</i> .
2	Check the field wiring.	Refer to <i>Section 3 - Installation</i> . Impedance must be less than or equal to 600 ohms.
3	Be sure all the recorder and control related data is correct.	Refer to <i>Section 4 - Configuration</i> . Check the tuning, algorithm, and control data.
4	Check the output.	Put the recorder into Manual Mode and raise/lower the output manually from 0% to 100% (4–20mA). Use a milliammeter at connection RLY1 terminals on the control output printed circuit board.
5	Recalibrate the current proportional output.	Refer to <i>Section 6 - Output Calibration</i> .
6	Replace the control output printed circuit board.	Refer to the replacement procedure in this section.

Continued on next page

7.5 Troubleshooting Procedures, Continued

Procedure #7

Table 7-12 explains what to do if the displayed output does not agree with the single relay or dual relay control output .

Table 7-12 Troubleshooting Relay Output Failure Symptoms

Step	What to do	How to do it or where to find the data
1	Be sure the recorder is configured for relay output.	Refer to <i>Section 2 - Setup Tasks</i> and <i>Section 3 - Configuration</i> .
2	Be sure all the recorder and control related data is correct.	Refer to <i>Section 4 - Configuration</i> . Check the Tuning, Algorithm, and Control data.
3	Check that the applicable output relay actuates properly. If it does, go to step 4.	Put the recorder into manual mode and adjust the output manually to raise or lower the PV around the setpoint. Listen for the click of the relay as the PV moves in either direction. Observe OUT 1 or 2 indicator on the front display.
4	Check the control relay jumper positions.	Refer to subsection 2.3 in <i>Section 2 - Setup Tasks</i> .
5	Check the field wiring.	Refer to <i>Section 3 - Installation</i> .
6	Replace the control output printed circuit board.	Refer to the replacement procedure in this section.

Continued on next page

7.5 Troubleshooting Procedures, Continued

Procedure #8

Table 7-13 explains what to do if the external alarm function does not operate properly.

Table 7-13 Troubleshooting External Alarm Function Failure Symptoms

Step	What to do	How to do it or where to find the data
1	Be sure all the alarm configuration data is correct.	Refer to <i>Section 4 - Configuration</i> .
2	Check the applicable alarm relay jumper position.	Refer to <i>Section 2 - Setup Tasks</i> .
3	Check the field wiring.	Refer to <i>Section 3 - Installation</i> .
4	Check that the applicable alarm relay actuates properly depending on ALARM TYPE configuration selection.	Alarms can be triggered either by: <ul style="list-style-type: none"> • reconfiguring the value of the trip points (AnSnVA), [n = 1 or 2] or: • connecting a signal generator to the input and setting the generator level beyond the trip-point values.

7.6 Replacement Procedures

Introduction

These procedures tell you how to access and replace the following parts in your recorder:

Procedure	Refer to:
Pen Arm #1	Table 7-14
Pen Arm #2	Table 7-15
Servo Plate Assembly	Table 7-16
Chart Motor	Table 7-17
Main Printed Circuit Board	Table 7-18
Display Printed Circuit Board and Keyboard	Table 7-19

Refer to the parts list section for a general orientation regarding the location of components.

WARNING Remove the power before accessing the components inside the case; failure to do so could result in personal injury.

Equipment needed

To accomplish the procedures that follow, you will need the following equipment:

- Phillips-head screwdriver,
- flat-bladed screwdriver, and
- small pliers.

Continued on next page

7.6 Replacement Procedures, Continued

Introduction

The procedures listed here assume that the chart door is opened, the chart plate is swung out, and power is removed. Refer to *Section 8 - Parts List* for a general orientation of the components.

WARNING To avoid personal injury, never access the components inside the case with power applied.

Replacing the No. 1 pen arm

Follow the procedure in Table 7-14 to replace the No. 1 pen arm.

Table 7-14 Replacing the No. 1 Pen Arm

Step	Action
1	Note the location of the pen (purple) on the chart. Pull the lifter up to raise the pen from the chart.
2	Remove the ink cartridge.
3	Remove the screw, lockwasher, and flat washer that hold the pen arm to the servo shaft. Remove the pen arm.
4	Replace the pen arm, flat washer, lockwasher, and screw, but leave the screw slightly loose. Replace the ink cartridge.
5	Push down the pen lifter and carefully position the pen to the location noted in step 1. Tighten the pen arm screw.
6	Refer to subsection 7.7 - "Checking the Pen Alignment".

Continued on next page

7.6 Replacement Procedures, Continued

Replacing the No. 2 pen arm

Follow the procedure in Table 7-15 to replace the No. 2 pen arm.

Table 7-15 Replacing the No. 2 Pen Arm

Step	Action
1	Note the location of pens on the chart. Pull the lifter up to raise the pens from the chart.
2	Remove the ink cartridges.
3	Remove the screw, lockwasher, and flat washer that hold the #1 pen arm to the servo shaft. Remove the pen arm.
4	Remove the screw, lockwasher, and flat washer that hold the #2 pen arm to the servo shaft. Remove the pen arm.
5	Replace the #2 pen arm, flat washer, lockwasher, and screw, but leave the screw slightly loose.
6	Replace the red ink cartridge on the No. 2 pen arm.
7	Push down the pen lifter and carefully position the #2 pen to the location noted in step 1. Tighten the No. 2 pen arm screw.
8	Replace the No. 1 pen arm, flat washer, lockwasher, and screw, but leave the screw slightly loose.
9	Raise the pen lifter and replace the purple ink cartridge on the No. 1 pen arm.
10	Push down the pen lifter and carefully position the #1 pen to the location noted in step 1. Tighten the No. 1 pen arm screw.
11	Refer to subsection 7.7 - "Checking the Pen Alignment".

Continued on next page

7.6 Replacement Procedures, Continued

Replacing the servo plate

ATTENTION Complement this procedure with the appropriate pen arm replacement procedure - No. 1 pen arm for 1-pen model or No. 2 pen arm for 2-pen model.

Follow the procedure in Table 7-16 to replace the Servo Plate.

Table 7-16 Replacing the Servo Plate

Step	Action
1	Remove the pen arm(s).
2	Note how the spring(s) is (are) attached to the servo plate. Disconnect the spring(s) from the servo plate.
3	Disconnect the No. 1 pen motor cable plug from J1 connector on the Main printed circuit board for pen #1 and the No. 2 pen motor cable from J2 connector on the Main printed circuit board for pen #2. Remove the cable(s) from the clamps in the rear of the case.
4	Remove the screws that hold the servo plate to the chart plate. Remove the servo plate.
5	Replace the servo plate and secure with the screws. Dress the cable(s) in the clamps and connect the cable plugs to the appropriate connector on the given Main printed circuit board. Connect the spring(s) to the servo assembly as noted in step 2.
6	Replace the pen arm(s).
7	Refer to subsection 7.7 - "Checking the Pen Alignment".

Replacing the chart motor

Follow the procedure in Table 7-17 to replace the Chart Motor.

Table 7-17 Replacing the Chart Motor

Step	Action
1	Pull up the pen lifter to raise the pen(s) from the chart.
2	Remove the chart. Pull the chart hub assembly from the motor shaft.
3	Disconnect the motor cable plug from J3 connector on the Main printed circuit board for Pen #1 and remove the cable from the clamps in the rear of the case.
4	Remove the screws holding the motor to the chart plate and remove the chart motor.
5	Replace the motor and secure it with screws. Dress the cable in the clamps and connect plug to J3 on the Main Printed Circuit Board for Pen #1.
6	Push the chart hub assembly that was removed in step 2 onto the motor shaft.
7	Close the chart plate and replace the chart. Set the chart time to the time index on the chart plate and push down the pen lifter.

Continued on next page

7.6 Replacement Procedures, Continued

Replacing the main printed circuit board

Follow the procedure in Table 7-18 to replace the Main Printed Circuit Board.

Table 7-18 Replacing the Main Printed Circuit Board

Step	Action
1	Tag and disconnect all the cable plugs from the connectors and the wiring from the terminal blocks on the Main printed circuit board.
ATTENTION If there is an Output printed circuit board mounted on the Main Printed Circuit Board go to step 2, if not go to step 4.	
2	Remove the 4-pin connector from J3 on the Main printed circuit board.
3	Remove the Output printed circuit board from the four spacers holding it to the Main printed circuit board. Remove the four spacers from the Main printed circuit board.
4	Remove the screws from the corners of the Main printed circuit board and lift the board from the case.
5	Install hardware jumpers and set dipswitch on new Main board.
6	Position the new Main printed circuit board in the case and secure with the screws.
ATTENTION If there is an Output printed circuit board mounted on the Main Printed Circuit Board go to step 7, if not go to step 11.	
7	Push the four plastic spacers into the holes on the right side of the new Main printed circuit board.
8	Hold the Output printed circuit board so that its mounting holes align with the spacers and plug the multi-pin connector from the output printed circuit board into J4 connector on the Main printed circuit board. Be sure that the plug positions are aligned and matched with the pins on J4.
9	Push down on each corner of the Output printed circuit board in turn to seat the board on the spacers.
10	Plug the 4-pin connector from the transformer on the Output printed circuit board into the J3 connector on the Main printed circuit board.
11	Replace the cable plugs and wiring to the connectors and terminal block as noted in step 1.
12	Refer to <i>Section 2 - Setup Tasks</i> and <i>Section 5 - Operation</i> to check the Main printed circuit board setup and operating parameter values.

Continued on next page

7.6 Replacement Procedures, Continued

Replacing the display and keyboard printed circuit board

Follow the procedure in Table 7-19 to replace the Display and Keyboard Printed Circuit Board.

Table 7-19 Replacing the Display and Keyboard Printed Circuit Board

Step	Action
1	Remove the ribbon cable from connector J4 on the Main printed circuit board.
2	Remove the 2 screws holding the display and keyboard printed circuit board to the top of the case and remove the PCB and ribbon cable from the case.
3	Secure the new PCB to the case with the screws removed in step 2.
4	Press ribbon cable in the case and connect the plug to connector J4 on the Main printed circuit board.
5	Apply power and check for normal display indication.

7.7 Checking Mechanical Pen Alignment at Zero

Procedure

You can mechanically align the pens to the zero position on the chart. Follow the procedure in Table 7-20 to check the mechanical pen alignment at zero.

Table 7-20 Check the Mechanical Pen Alignment

Step	Press	Action/Result
1		Loosen the locking screw in the #1 pen arm. Move #1 pen arm down and loosen the locking screw in the #2 pen arm. ATTENTION If the recorder only has one pen, skip steps 2-5.
2	FUNC	To ensure "INP2" indicator is lit on the front display.
3	DISP and MAN AUTO together	To initiate the self test for pen #2.
4		Wait 20 seconds for pen 2 to initialize. Then, move the pen arm to set pen #2 tip on the zero (0) line of the chart $\pm 0.5\%$ (or a half a graduation). Tighten #2 pen arm locking screw.
5	DISP then FUNC	To return to normal operation for pen #2. To toggle to "INP1" on the front display.
6	DISP and MAN AUTO together	To initiate the self test for pen #1.
7		Wait 20 seconds for pen 1 to initialize. Then, move the pen arm to set pen #1 tip on the zero (0) line of the chart $\pm 0.5\%$ (or a half a graduation). Tighten #1 pen arm locking screw.
8	DISP	To return to normal operation for pen #1.

7.8 Checking the Electrical Pen Alignment at Span and Zero

Introduction

If the pen trace does not track at the correct chart increment with a known input value, you can use the following procedures to adjust the pen travel at zero and span (full scale) to compensate for the effects of humidity on the chart size.

If the recorder has 2 pens, be sure Input1 (INP1) is on the display. If it isn't on display, press **FUNC** key to toggle input for display.

Procedure

Follow the procedure in Table 7-21 to align the pens.

Table 7-21 Electrical Pen Alignment at Span and Zero















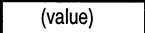

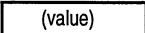
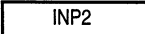

Step	Press	Action/Result
1	SET UP	until you can see: Upper Display ALIN Lower Display PEN
2	FUNC	until you can see: Upper Display (value) (approximately 60 on the upper display) Lower Display PENO Wait until pen stops moving.
	 or 	to set pen #1 tip on zero line of chart $\pm 0.25\%$ (or quarter graduation).
3	FUNC	and you will see: Upper Display (value) (approximately 1200 more than the zero value on the upper display) Lower Display PEN 100 Wait until pen stops moving.
	 or 	to set pen #1 tip on full scale line of chart $\pm 0.25\%$ (or quarter graduation).

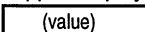
Table 7-21 continued on next page

7.8 Checking the Electrical Pen Alignment at Span and Zero, Continued

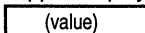
Procedure, continued

Table 7-21 Electrical Pen Alignment at Span and Zero, continued

Step	Press	Action/Result
4		to return to normal operation for pen #1. you will see: Upper Display  Lower Display  If the recorder has 2 pens go to step 5.
5		you will see: Upper Display  Lower Display 
6		until you see: Upper Display  Lower Display 
7		and you will see: Upper Display  Lower Display  wait until pen stops moving.
	 or 	to set pen #2 tip on zero line of chart $\pm 0.25\%$ (or quarter graduation).
8		and you will see: Upper Display  Lower Display  wait until pen stops moving.
	 or 	to set pen #2 tip on full scale line of chart $\pm 0.25\%$ (or quarter graduation).

7.8 Checking the Electrical Pen Alignment at Span and Zero, Continued

Procedure, continued

Table 7-21 Electrical Pen Alignment at Span and Zero, continued

Step	Press	Action/Result
9	<div style="border: 1px solid black; padding: 2px; display: inline-block;">DISP</div>	to return to normal operation for pen #2. You will see: Upper Display <div style="border: 1px solid black; padding: 2px; display: inline-block;">(value)</div> Lower Display <div style="border: 1px solid black; padding: 2px; display: inline-block;">INP2</div>

Section 8 – Parts List

8.1 Overview

Introduction

This section provides the replacement parts lists for the DR4200 Model EV Circular Chart Recorder. Most parts are supplied on an optimum replacement unit basis; that is, part numbers are given for complete printed circuit boards rather than for individual PCB components.

- The figures that follow are exploded views of the DR4200 Model EV recorder. Each part is labeled with a key number and the key numbers are listed in tables with associated part numbers.
- When ordering parts, be sure to specify your recorder's serial and model numbers (on chartplate) as well as the part identification.

www.DataSheet4U.com

What's in this section? This section contains the following topics:

Topic		See Page
8.1	Overview	137
8.2	Exploded Views	
	Figure 8-1 Door Assembly	138
	Figure 8-2 Chart Plate	140
	Figure 8-3 Basic Recorder components without options	141
	Figure 8-4 Additional Recorder components associated with options	142

8.2 Exploded Views

Door assembly

Figure 8-1 is an exploded view of the Door Assembly.
Table 8-1 is a list of the associated part numbers.

Figure 8-1 Door Assembly

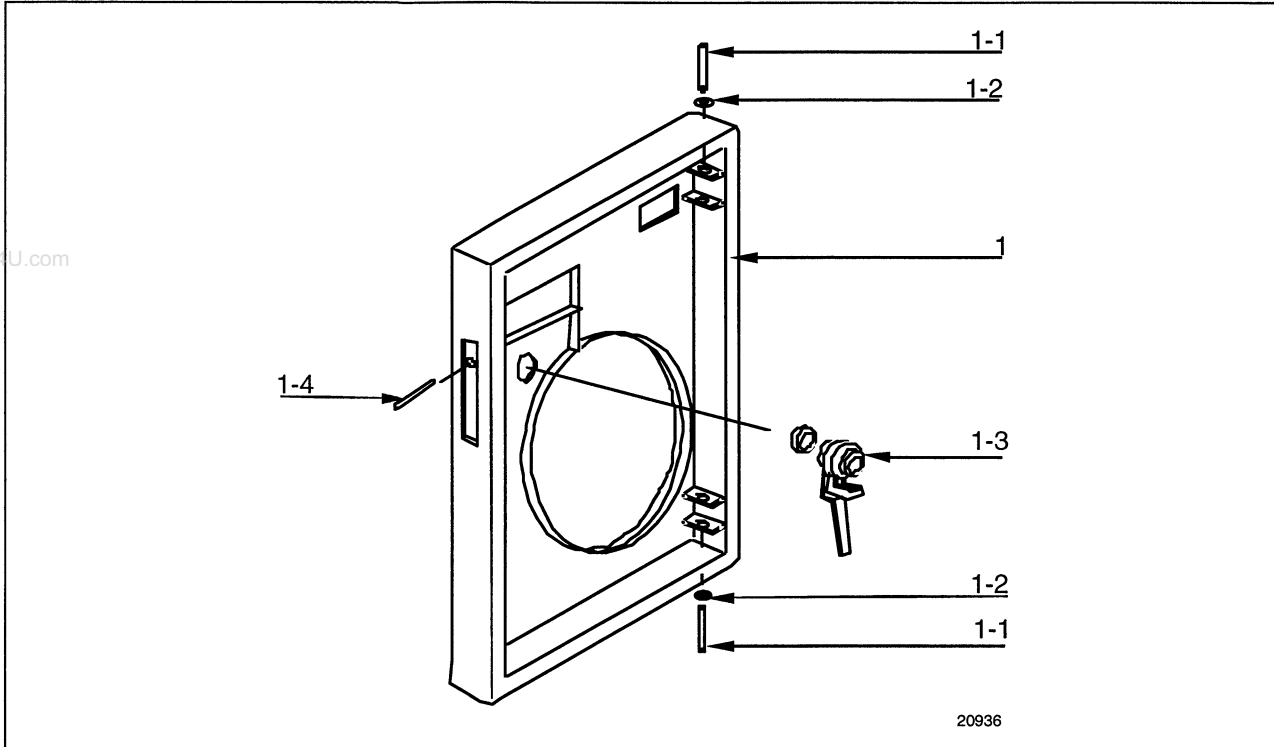

Table 8-1 Door Assembly Parts

Key	Part Number	Description	Recommended Spare Parts Per		Quantity per Unit
			10	100	
1		Door Assembly			1
	30755825-501	Blue Door - Glass Window and Latch			
	30755825-502	Blue Door - Acrylic Window and Lock			
	30755825-503	Blue Door - Glass Window and Lock			
	30755825-504	Blue Door - Acrylic Window and Latch			
	30755825-505	Black Door - Glass Window and Latch			
	30755825-506	Black Door - Acrylic Window and Lock			
	30755825-507	Black Door - Glass Window and Lock			
	30755825-508	Black Door - Acrylic Window and Latch			
	30755825-509	Beige Door - Glass Window and Latch			
	30755825-510	Beige Door - Acrylic Window and Lock			
	30755825-511	Beige Door - Glass Window and Lock			
	30755825-512	Beige Door - Acrylic Window and Latch			
	30755825-513	Gray Door - Glass Window and Latch			
	30755825-514	Gray Door - Acrylic Window and Lock			
	30755825-515	Gray Door - Glass Window and Lock			
	30755825-516	Gray Door - Acrylic Window and Latch			
	30755825-517	Blue Door - Glass Window and Heavy Duty Latch			
	30755825-518	Blue Door - Acrylic Window and Heavy Duty Latch			
	30755825-519	Black Door - Glass Window and Heavy Duty Latch			
	30755825-520	Black Door - Acrylic Window and Heavy Duty Latch			
30755825-521	Beige Door - Glass Window and Heavy Duty Latch				

Table 8-1 is continued on next page

8.2 Exploded Views, Continued

Door assembly, continued

Table 8-1 Door Assembly Parts, continued

Key	Part Number	Description	Recommended Spare Parts Per		Quantity per Unit
			10	100	
1	30755825-522 30755825-523 30755825-524 30756045-501 30756045-502 30756045-503 30756045-504 30756045-505 30756045-506 30756045-507 30756045-508 30756045-509 30756045-510 30756045-511 30756045-512 30756045-513 30756045-514 30756045-515 30756045-516	Door Assembly, continued Beige Door - Acrylic Window and Heavy Duty Latch Gray Door - Glass Window and Heavy Duty Latch Gray Door - Acrylic Window and Heavy Duty Latch Heavy Duty Gray Door - Acrylic Window and Lock Heavy Duty Blue Door - Acrylic Window and Lock Heavy Duty Gray Door - Glass Window and Lock Heavy Duty Blue Door - Glass Window and Lock Heavy Duty Beige Door - Plastic Window and Lock Heavy Duty Black Door - Plastic Window and Lock Heavy Duty Beige Door - Glass Window and Lock Heavy Duty Black Door - Glass Window and Lock Heavy Duty Gray Door - Acrylic Window and Heavy Duty Latch Heavy Duty Blue Door - Acrylic Window and Heavy Duty Latch Heavy Duty Gray Door - Glass Window and Heavy Duty Latch Heavy Duty Blue Door - Glass Window and Heavy Duty Latch Heavy Duty Beige Door - Acrylic Window and Heavy Duty Latch Heavy Duty Black Door - Acrylic Window and Heavy Duty Latch Heavy Duty Beige Door - Glass Window and Heavy Duty Latch Heavy Duty Black Door - Glass Window and Heavy Duty Latch			1
1-1	(K)30756409-001	Hinge Pin*			2
1-2	(K)30756409-001	Retaining Ring*			2
1-3	(K)30756409-001 30756584-001 30756584-002	Latch without lock and with gasket Latch Assembly for Heavy Duty Door Lock Assembly Kit	1	3	1
1-4	(K)30756409-001	Latch Pin*			1
	30755822-002	Graphic Overlay for Door - not shown*			1

*Parts included with applicable door assembly.

(K) denotes that the part number is for the parts kit in which the described part is included. The described part cannot be ordered separately.

8.2 Exploded Views, Continued

Chart plate

Figure 8-2 is an exploded view of the Chart Plate Assembly.
Table 8-2 is a list of the associated part numbers.

Figure 8-2 Chart Plate Assembly

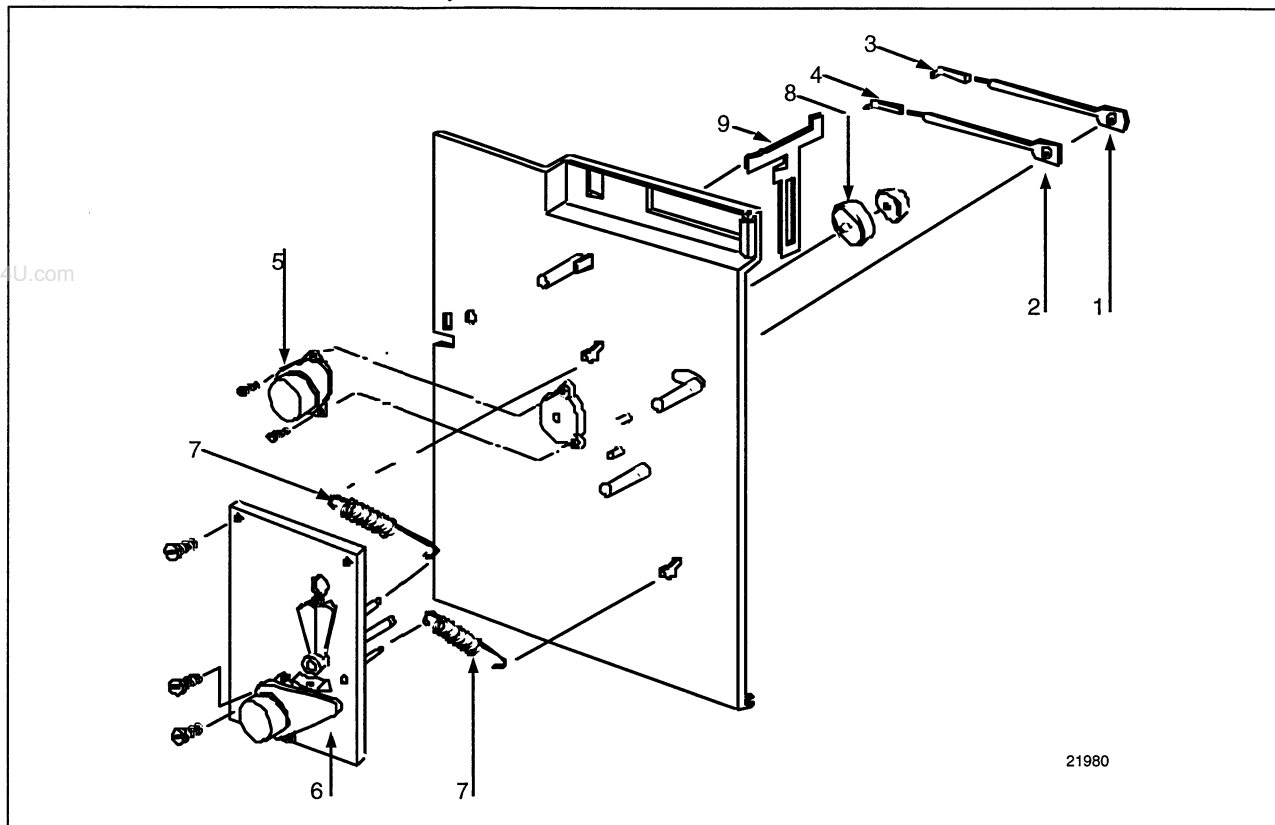

Table 8-2 Chart Plate Assembly Parts

Key	Part Number	Description	Recommended Spare Parts Per		Quantity per Unit
			10	100	
1	(K)30756409-002	No. 1 Pen Arm	1	5	1
2	(K)30756409-002	No. 2 Pen Arm (2-pen model only)	1	5	1
3	30735489-007	No. 1 Purple Pen Cartridge (Six Pack)	1	3	1
4	30735489-002	No. 2 Red Pen Cartridge (Six Pack)	1	3	1
5	30756113-501	Chart Motor	1	3	1
6	30755833-501 30755833-502	Servo Motor Assembly 1-pen model 2-pen model			1
7	(K)30756409-002	Spring, Tension			1/2
8	(K)30756150-001	Chart Hub Kit (includes 2 hubs and 2 adapters)			1
9	(K)30756409-002	Pen Lifter Retainer			1

(K) denotes that the part number is for the parts kit in which the described part is included. The described part cannot be ordered separately.

Continued on next page

8.2 Exploded Views, Continued

Basic recorder components without options

Figure 8-3 is an exploded view of the Basic Recorder components without options.

Table 8-3 is a list of the associated part numbers.

Figure 8-3 Basic Recorder Components Without Options

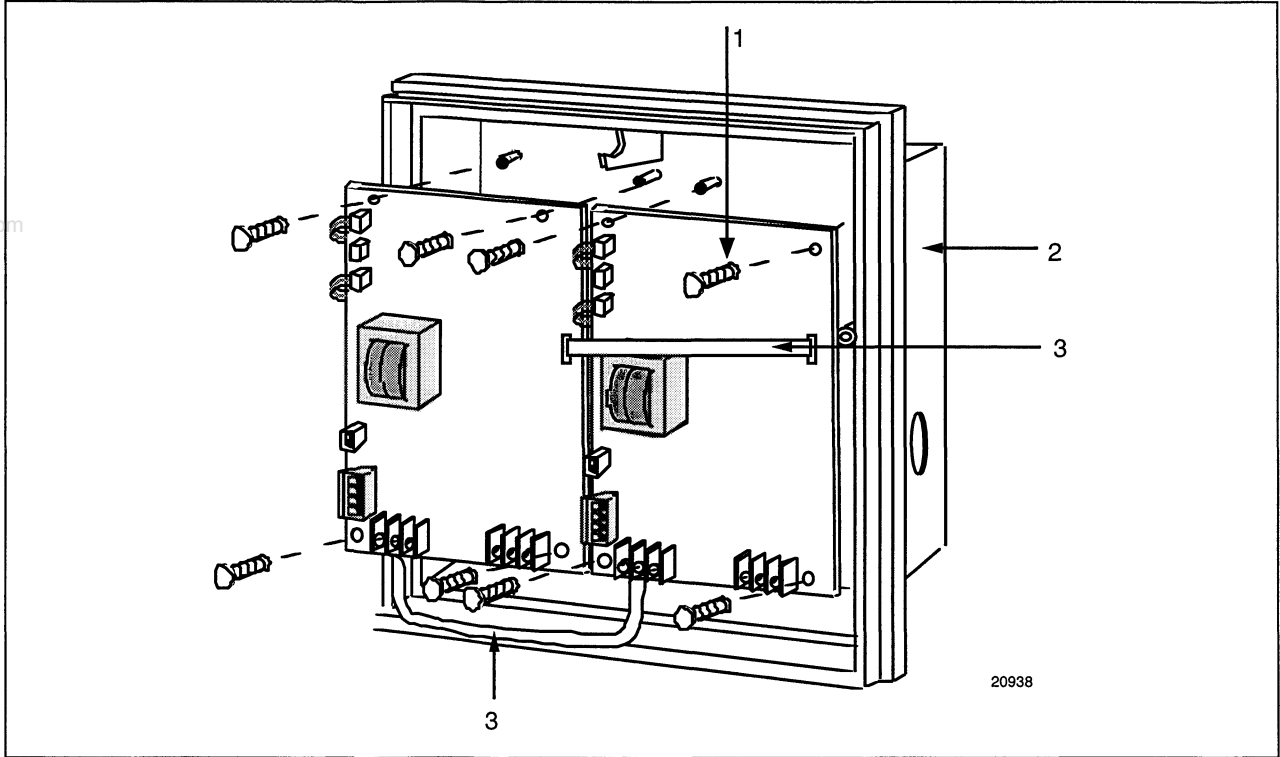

Table 8-3 Basic Recorder Parts without Options

Key	Part Number	Description	Recommended Spare Parts Per		Quantity per Unit
			10	100	
1	30756081-501	Main PCB - <i>without</i> totalizer option	1	3	1/2
	51309339-501	Main PCB- <i>without</i> totalizer option - <i>with</i> CE Mark option			
	30756906-001	Main PCB - <i>with</i> Totalizer option			
	30756906-003	Main PCB- <i>with</i> Totalizer option - <i>with</i> CE Mark option			
	30756906-002	Totalizer Upgrade kit (not shown)			
2	30755800-501	Case	1	3	1
	30755800-502	Case - CE Mark option			
3	30757235-001	Cable Replacement Kit	1	3	1
	51197653-002	Cable Replacement Kit - CE Mark option			
	30756084-501	Display and keyboard PCB (not shown)	1	3	1
	51197612-502	Round cable suppression cores (CE Mark), package of 2 (not shown)	1	3	up to 3
	51197612-508	Round cable suppression cores (CE Mark), package of 8 (not shown)	1	1	1

Continued on next page

8.2 Exploded Views, Continued

Additional recorder components associated with options

Figure 8-4 is an exploded view of the Recorder components associated with options.

Table 8-4 is a list of the associated part numbers.

Figure 8-4 Recorder Components Associated With Options

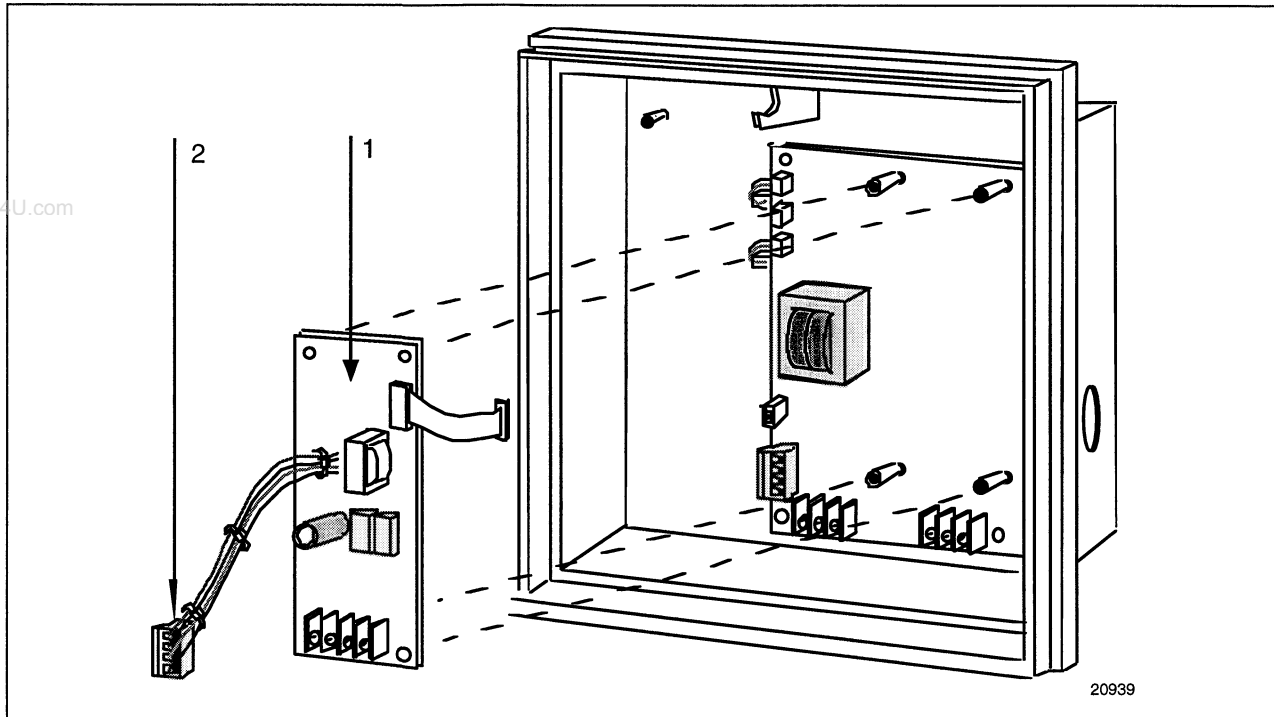

Table 8-4 Recorder Parts Associated With Options

Key	Part Number	Description	Recommended Spare Parts Per		Quantity per Unit
			10	100	
1	30756087-501	Current/relay Control Output PCB assembly (includes four stand-offs)	1	5	1/2
	30756087-502	Relay only Control Output PCB assembly			
	30756087-503	24 Vdc Output PCB assembly			
2	(K) 30755980-003	Four-position connector			1

(K) denotes that the part number is for the parts kit in which the described part is included. The described part cannot be ordered separately.

Appendix A – Manual Tuning

A.1 Overview

Introduction

When you tune a control output, there are some things to consider:

- Process Characteristics - Gain, Time Constants, etc.
- Desired response - Minimal overshoot

Basically, control tuning consists of determining the appropriate values for the Gain (PB), Rate (Derivative), and Reset (Integral) time tuning parameters (control constants) that will give the control you want. Depending on the characteristics of the deviation of the process variable from the setpoint, the tuning parameters interact to alter the control output and produce changes in the value of the process variable.

Since each parameter responds to a specific characteristic of the deviation, you may not need a combination of all three. It depends on the process characteristics and the desired control response.

Tuning technique

You can estimate a starting point and the tuning parameters required to give the desired control response and with some experience become proficient with this method.

An alternate approach is to rely on a tuning technique. In practice, tuning techniques usually do not give exactly the type of response desired; thus, some final adjustments to the tuning parameters must be made.

However, you should at least obtain a reasonable starting point from which the desired response characteristics can be obtained.

Control tuning procedures

There are two procedures for tuning the control output:

- Time or Current Proportional simplex control, or
- Duplex Time Proportional control, and

The suggested procedures describe how to establish and store values of Gain (PB), Rate, and Reset time constants for your process. You must know the type of control and algorithm your recorder has.

2 pen recorders

If you have a 2-pen recorder with a control loop for each pen, be sure to tune both control loops independently with the correct input (1 or 2) on the operator interface display.

A.2 Time or Current Proportional Simplex Control

Procedure

The procedure listed in Table A-1 gives you the steps for manually tuning a recorder with Time or Current proportional simplex control.

Table A-1 Manual Tuning Procedure for Simplex Control

Step	Action
1	In manual mode, adjust the output to bring the PV (Process Variable) near the desired value.
2	Set the rate time (RATET) to 0 minutes and set the reset time (IMIN) to the maximum value (50.00 minutes) or set repeats/min (IRPM) to the minimum value to minimize reset action. If applicable, set the CYCLE TIME (CYCT1) to 4 seconds and DEADBAND (DBAND) to 0.5.
3	Increase GAIN (decrease PB) significantly. Try a factor of 10.
4	Adjust the setpoint to equal PV and switch to automatic control mode.
5	Increase the setpoint by 5 or 10% and observe the process variable response.
6	If the PV oscillates, continue to step 7. If it does not oscillate, return to the original setpoint and increase GAIN (decrease PB) again by a factor of 2, and repeat step 5.
7	<p>Compare the oscillations with the figure below:</p>  <p style="text-align: right;">21457</p> <ul style="list-style-type: none"> • If the oscillation matches pattern A, go to step 8. • If the oscillation matches pattern B, increase GAIN (decrease PB) by a factor of 2 and repeat steps 4 to 6. • If the oscillation matches pattern C, decrease GAIN (increase PB) by a factor of 0.8 and repeat steps 4 to 6 <p>The amplitude of the cycle is immaterial, but all of the elements of the loop must be within the operating range (that is, the valve must not go full open or closed).</p>
8	Record the current value of GAIN (or PB) and measure and record the value of time for one completed oscillation of PV.

Table A-1 is continued on next page

A.2 Time or Current Proportional Simplex Control, Continued

Procedure, continued

Table A-1 Manual Tuning Procedure for Simplex Control, continued

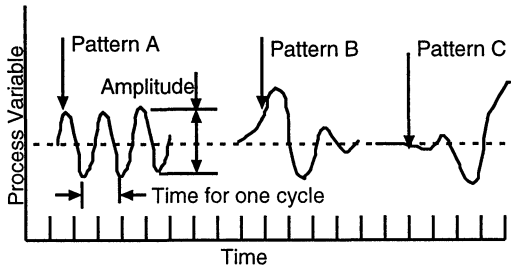
Step	Action
9	Select the proper set of formulas from Table A-2. Use the values of Gain (or PB) and time (in minutes) in the formulas to arrive at the recorder's tuning parameters settings.
10	<p>Enter the values of GAIN (GN) (or PB), RATE (RATET), and RESET in minutes (IMIN) (or repeats per minute (IRPM)) into the recorder and verify that the PV response is adequate.</p> <ul style="list-style-type: none"> • If you are using proportional control with manual reset, compare the pen trace with those in Figure A-1 to determine if any further fine tuning is required. • If you are using proportional control plus reset, and/or plus rate, compare the pen traces to those in Figure A-2 to determine if any further fine tuning is required. <p>Make additional trimming adjustments, if necessary, to fine tune the recorder per the guidelines shown in the figures.</p>

Manual tuning formulas Table A-2 lists the formulas used in the procedure listed in Table A-1.

Table A-2 Manual Tuning Formulas

	Units	
	GAIN and RESET TIME in <u>Minutes</u> Repeat	% PROPORTIONAL BAND and RESET ACTION in <u>Repeats</u> Minutes
Proportional (P) only	GAIN = Measured Gain x 0.5 RESET TIME = 50.00 (minimum reset) RATE = 0	%PB = Measured PB x 2 RESET ACTION = 0.02 (repeats/minute) RATE = 0
Proportional + Reset (PI) (No Rate)	GAIN = Measured Gain x 0.5 RESET TIME = $\frac{\text{Measured Time}}{1.2}$ (M/R) RATE = 0	%PB = Measured PB x 2.2 RESET ACTION = $\frac{1.2}{(R/M) \text{ Measured Time}}$ RATE = 0
Proportional + Reset + Rate (PID)	GAIN = Measured Gain x 0.6 RESET TIME = $\frac{\text{Measured Time}}{2}$ RATE = $\frac{\text{Measured Time}}{8}$	%PB = Measured PB x 1.7 RESET ACTION = $\frac{2}{\text{Measured Time}}$ RATE = $\frac{\text{Measured Time}}{8}$

Continued on next page

A.2 Time or Current Proportional Simplex Control, Continued

Pen traces (proportional plus manual reset) Figure A-1 shows the pen traces identifying the need for tuning constant plus adjustment (proportional plus manual reset)

Figure A-1 Pen Traces (Proportional Plus Manual Reset)

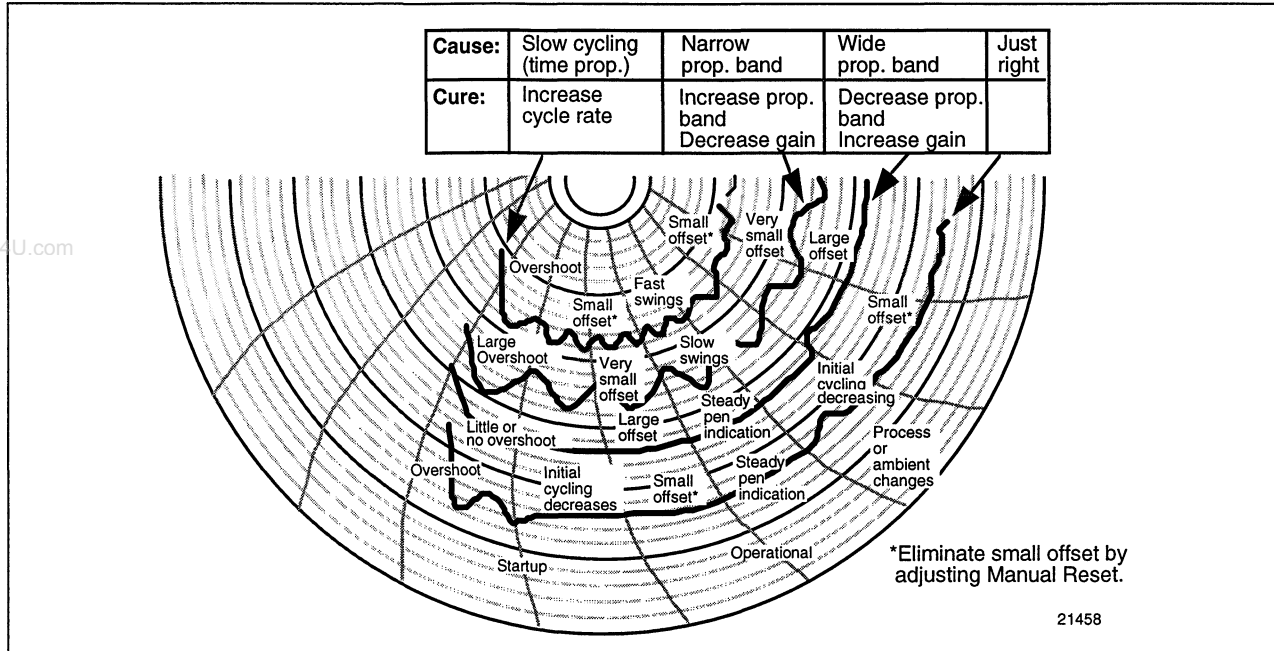

Pen traces (proportional plus reset and/or plus rate) Figure A-2 shows the pen traces identifying the need for tuning constant plus adjustment (proportional plus reset and/or plus rate)

Figure A-2 Pen Traces (Proportional Plus Reset and/or Plus Rate)

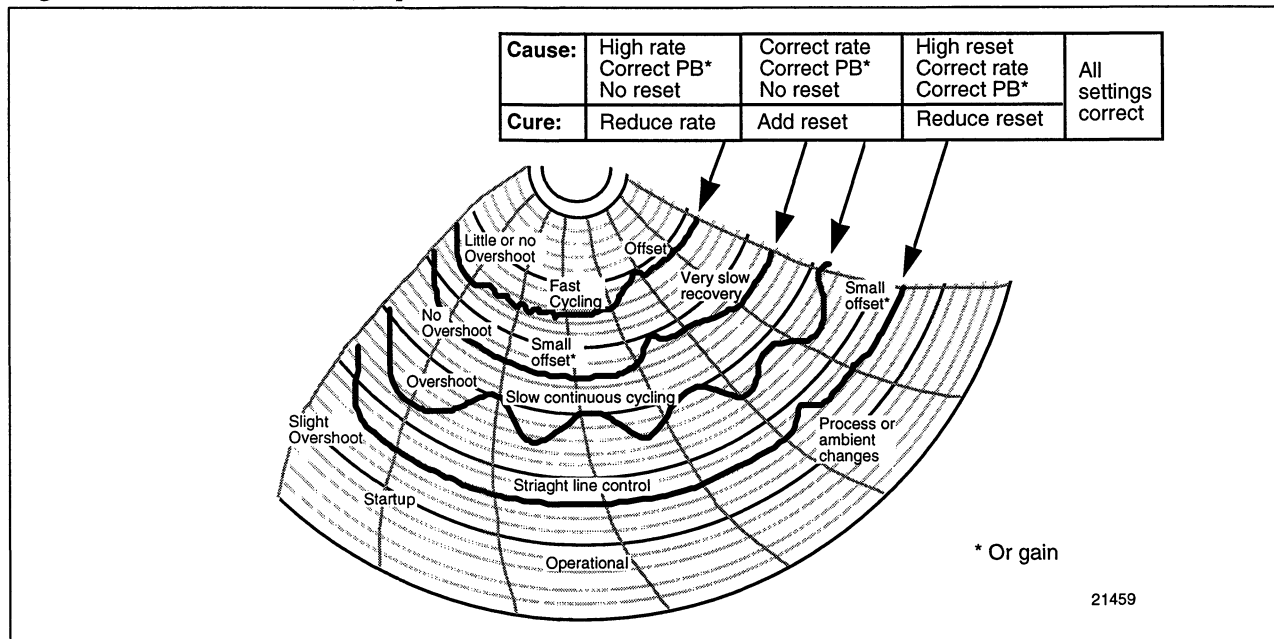

A.3 Time Proportional Duplex Control

Introduction

For HEAT/COOL applications.

Tune the control output with the output above 50% for heat and below 50% for cool.

HEAT/COOL prompts

The "TUNING" function prompts for HEAT/COOL are:

HEAT

GAIN (Pb or GN)
RESET (IRPM or IMIN)
RATE (RATE)
CYCLE (CYCTI)

COOL

GAIN2 (Pb2 or GN2)
RESET2 (I2RPM or I2MIN)
RATE2 (RATE2T)
CYCLE2 (CYC2TI)

Appendix B

How to Apply Digital Instrumentation in Severe Electrical Noise Environments

B.1 Overview

Guideline overview

Products that incorporate digital technology provide recognized performance advantages over conventional analog instrumentation used for process control. These advantages can result in better product uniformity and greater overall efficiency when used correctly.

There are, however, certain guidelines regarding installation and wiring which must be carefully followed in order to achieve this performance. In addition to the traditional precaution of the separation of signal and power wiring in separate conduits, other measures must be taken to minimize the effects of electromagnetic interference (EMI) and radio frequency interference (RFI) on the operation of the equipment. Otherwise, if high level, short duration, noise spikes are permitted to enter the digital equipment, the noise can be transferred into the system's logic networks and can be misinterpreted as signal data, resulting in erroneous system operation and other unpredictable responses.

What's in this section

This section contains the following information:

	Topic	See Page
B.1	Overview	149
B.2	Potential Noise Sources	150
B.3	Prevention Methods	151
B.4	Recommended Wiring Practices	152
B.5	Power Source Considerations	154
B.6	Noise Suppression at the Source	155

B.2 Potential Noise Sources

Overview

Noise can enter electronic equipment via three methods of coupling, namely:

- Capacitive (or electrostatic)
 - Inductive (or magnetic)
 - Impedance
-

Capacitive and inductive coupling

Capacitive and inductive coupling have the same essential effect — they couple current or voltage, without any actual connection of the two circuits. Impedance coupling requires a connection between the two circuits. Typical noise-generating sources that could affect electronic equipment through capacitive and inductive coupling include:

- Relay coils
 - Solenoids
 - AC power wires — particularly at or above 100 Vac
 - Current carrying cables
 - Thyristor field exciters
 - Radio frequency transmissions
-

Impedance coupled noise

Impedance-coupled noise may enter by way of the lines used to power the digital equipment or by way of improper grounding. Most power lines, at typical industrial locations, are far from noise-free. The noise on them can be generated in many ways, but are nearly always associated with switching circuits of some nature.

These include:

- Large relays
- Contactors
- Motor starters
- Business and industrial machines
- Power tools
- HID (high-intensity discharge) lights
- Silicon controlled rectifiers (SCRs) that are phase-angled fired

These devices generate noise by lowering the line voltage during energization when large currents are drawn for short periods of time.

B.3 Prevention Methods

Introduction

There are three ways to prevent electrical noise from interfering with the operation of the electronic digital equipment:

- Built-in noise rejection
 - Separation of signal and power lines
 - Noise suppression at source
-

Built-in noise rejection

The first method is to design the digital equipment with a high degree of noise rejection built-in. This includes housing the equipment in a case that will provide shielding, liberal use of noise rejection filters and opto-isolators, and the use of noise suppressers on potential noise sources within the equipment itself. This, of course, is the responsibility of the manufacturer who usually performs extensive laboratory and field testing of newly designed digital equipment to insure the adequacy of its immunity to noise. As a minimum requirement, the equipment should be able to pass the tests outlined in the IEEE Standard 472-1974 (*Surge Withstand Capacity Tests*).

Signal and power line separation

The second method is to prevent noise from getting on the signal and power lines that are connected to the equipment. This is achieved by proper separation and shielding of those lines. In some cases, separate power lines or special power line regulation or filtering may be required for satisfactory electronic digital equipment operation. It is the responsibility of the installer to follow good wiring practices.

Suppression at the source

The third prevention method is to suppress the noise at its source. This is the most effective but also the most difficult because it is not easy to identify all of the potential noise sources in a typical industrial installation. Therefore, "suppression" is usually a last resort for those extreme situations where the other methods are insufficient by themselves. See *Noise Suppression at Source* which follows.

B.4 Recommended Wiring Practices

General rules

- All wiring must conform to local codes and practices.
- Wires carrying similar types of signals (Table B-1) may be bundled together, but bundles with different types of signals must be kept separated to prevent inductive or capacitive coupling.

Wire bundling

Table B-1 shows what wiring should be bundled together to prevent inductive or capacitive coupling.

Table B-1 External Wiring

Wire Function		Bundle No.	Are Shielded Twisted Wires Recommended?
No.	Type		
1 2 3	HIGH VOLTAGE Line Power Earth Ground Line Voltage Digital I/O	1	NO
4 5	ANALOG I/O Process Variable RTD Thermocouple dc Millivolts Low level (<100V) 4-20 mA dc 1-5 Vdc	2	YES
6 7	DIGITAL I/O Low Voltage (<100V) Computer Interface	3	YES

Continued on next page

B.4 Recommended Wiring Practices, Continued

Additional rules

Please observe these additional rules for wire bundling:

- For distances over five (5) feet, and when shielding is recommended, use a separate metal tray or conduit for each bundle. Where conduits or trays are not practical, use twisted wires with a metal overbraid and provide physical separation of at least one foot.
 - Tray covers must be in continuous contact with the side rails of the trays.
 - When unlike signal levels must cross, either in trays or conduits, they should cross at a 90-degree angle and at a maximum spacing. Where it is not possible to provide spacing, a grounded steel barrier or grid should be placed between the unlike levels at the crossover points.
 - Trays containing low level wiring should have solid bottoms and sides. Tray covers must be used for complete shielding. Tray cover contact with side rails must be positive and continuous to avoid high reluctance air gaps, which impair shielding. Trays for low level cables should be metal and solidly grounded.
 - Wires containing low level signals should not be routed near any of the following:
 - Contactors
 - Motors
 - Generators
 - Radio transmitters
 - Wires carrying high current that is being switched on and off
 - Use a 12-gage (or heavier) insulated stranded wire for the ground connection. Attach it firmly to a proven good earth ground such as a metal stake driven into the ground.
 - All shields should be grounded at one end only — preferably the instrument end.
-

B.5 Power Source Considerations

Operate within limits

The AC power for the digital electronic equipment must be within the voltage and frequency limits specified for that equipment. Attempts to operate outside the specified limits will result in no performance. For those installations where the supply voltage will not stay within the specified limits, a ferroresonant transformer, for voltage resolution, should be used.

Independent AC source

For protection against noise, the AC source for the digital electronic equipment should be independent of all other loads especially when switching loads are involved. For example, it should not provide power for air-conditioning, convenience outlets, lighting, motors, or similar noise-generating devices. To obtain electrical isolation (see Figure B-1) a separate transformer is required to supply power to the digital equipment. For additional noise and transient rejection, shielded primary and secondary windings may be required. And, if necessary, power line filters may be added to attenuate noise signals that have a higher frequency than the power line frequency.

Transformer for digital equipment

Figure B-1 is an illustration of a separate transformer required to supply power to digital equipment.

Figure B-1 Transformer for Digital Equipment

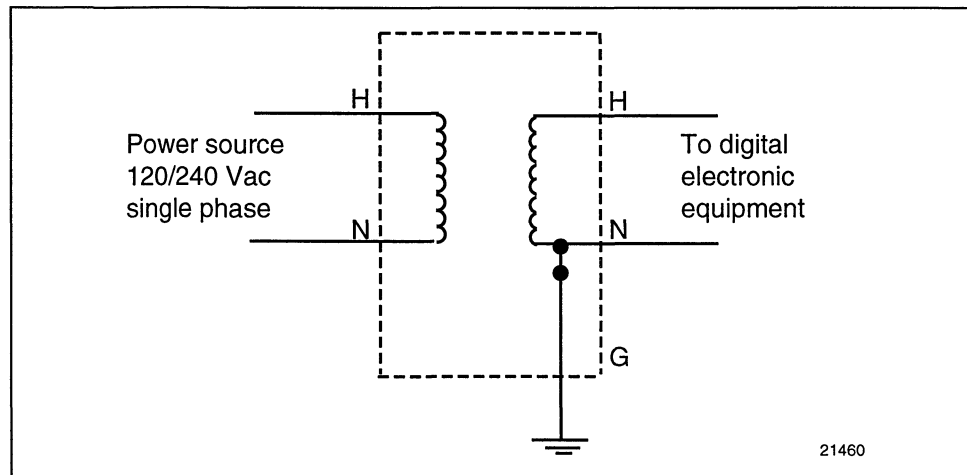

B.6 Noise Suppression at the Source

Introduction

Generally speaking, when good wiring practices are used with well-designed digital electronic equipment, no further noise protection is necessary. However, in some severe electrical environments, the magnitude of the electrical noise is so great that it must be suppressed at the source. In most control cabinets, the main sources of noise are motor starters, contactors, relays, and switching gear. For this reason, many manufacturers of these devices supply “surge suppressers” which mount directly on the noise source, (for example, on the coil of a control relay or motor starter).

For those devices that do not have accessory “surge suppressers,” resistance capacitance (RC) circuits and/or voltage limiters such as metal varistors may be added when and where needed. This can be broken down into two categories, namely inductive loads (for example, a relay switch in series with a relay coil) and contacts.

Inductive coils

Metal Oxide Varistors (MOVs) are recommended for transient suppression in inductive coils. An MOV is connected in parallel with the coil and is as close as physically possible to the coil (see Figure B-2). MOV devices (listed in Table B-2) are recommended for general purpose applications.

Table B-2 lists part numbers for recommended MOV devices.

Table B-2 MOV Devices

Part Number	30732481-001 *	30732481-002
Maximum AC	130V	275V
Energy Pulse Rating	10 Joules	15 Joules
Supplier (General Electric)	V130LA10A	V275LA15A

Continued on next page

B.6 Noise Suppression at the Source, Continued

Inductive coils, continued

Figure B-2 is an illustration of transient suppression in inductive coils.

Figure B-2 Transient Suppression in Inductive Coils

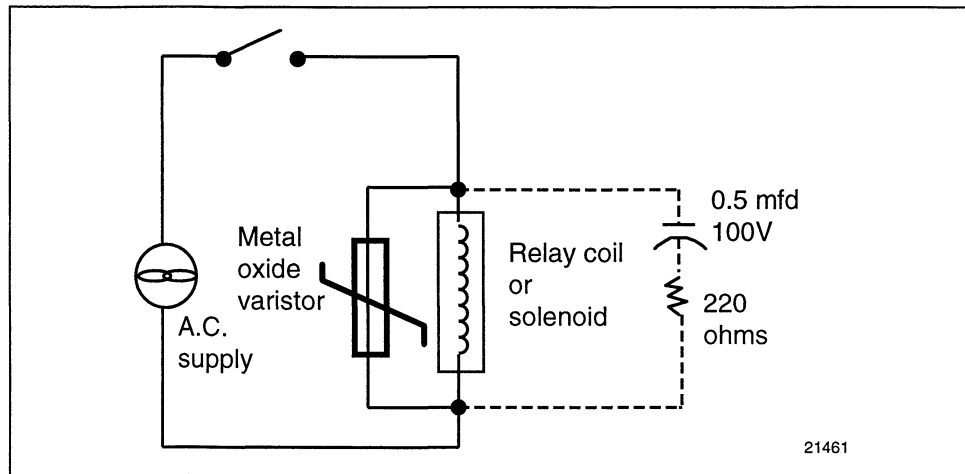

Additional protection may be provided by adding an RC circuit in parallel with the MOV. This consists of a 220-ohm resistor in series with a 0.5 microfarad, 1000V capacitor. The power rating of the resistor will depend on the voltage rating of the coil (see Table B-3).

Table B-3 Coil Voltage vs Resistor Voltage Rating

Coil Voltage	Resistor Voltage Rating
115V	1/4 Watt
230V	1 Watt
460V	3 Watt
550V	5 Watt

Continued on next page

B.6 Noise Suppression at the Source, Continued

Contacts

When a contact interrupts an inductive load, a certain amount of energy is stored in the load. An MOV or RC circuit in parallel with the load provides a place where this energy may be dissipated. However, if there is no MOV or RC circuit, the energy may create a visible electrical arc across the open contacts. This, in turn, results in electrical noise as well as damage to the contacts.

One way to eliminate this arc is to connect a resistor and capacitor across the contacts (see Figure B-3). A combination of 47 ohms and 0.1 microfarads (1000 Vdc) is recommended for circuits up to 3 amps and 300 Vac. For voltages above 2000 Vac, an MOV across the contact may be added for extra protection.

Figure B-3 is an illustration of a resistor and capacitor connected across a contact to eliminate electrical noise.

Figure B-3 Contact Noise Suppression

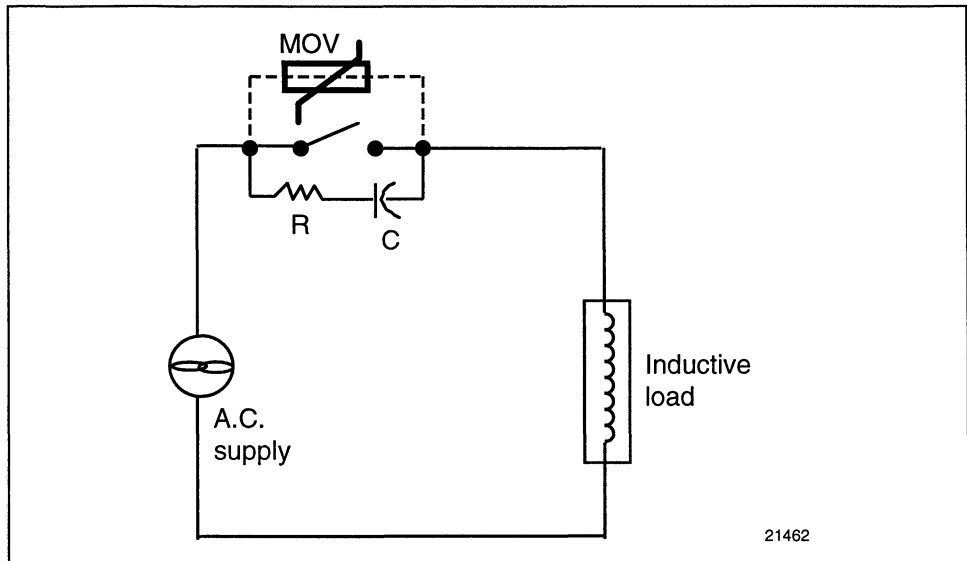

For large load currents, a rule of thumb is to size the capacitor so that the number of microfarads equals the number of amperes in the load current, and the resistor has the same resistance value as the load. The objective is to eliminate the visible arc.

Either discrete resistors and capacitors or packaged RC networks may be used. An RC network (47 ohms and 0.1 microfarad) is available from Honeywell as part number 30371852-001. Similar RC networks are available from Electrocube Inc. (part number RG1782-3) and from Industrial Condenser Corporation.

Continued on next page

B.6 Noise Suppression at the Source, Continued

Contacts, continued

In DC circuits, the power dissipation under steady state condition can be eliminated by placing a diode (in series with a resistor) in parallel with the load (see Figure B-4). The value of R should be less than or equal to the DC resistance of the inductive load.

Figure B-4 is an illustration of DC load noise suppression.

Figure B-4 DC Load Noise Suppression

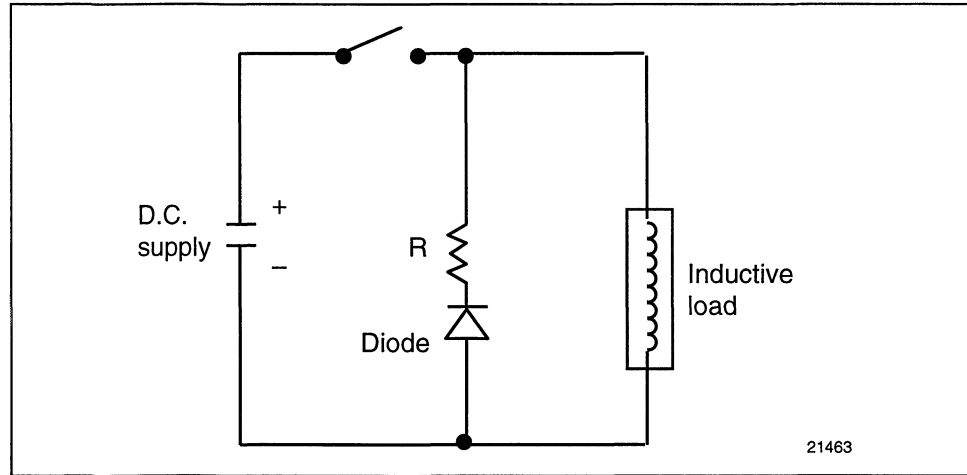

Appendix C - Accuracy

C.1 Overview

Reference accuracy

The Reference Accuracy varies according to the type of input actuation.

Table C-1 lists the types of input actuations and their reference accuracy.

These figures include reference junction calibration of ± 0.01 degrees using the standard "ice bath" method of calibration. Factory calibration at reference ± 1.2 °F. Note that factory calibration may have typical variations of ± 150 microvolts or ± 0.6 ohms for RTDs which means recalibration may be required to achieve stated accuracy.

www.DataSheet4U.com Table C-1 Reference Accuracy

Types of Input Actuations	Range		Reference Accuracy*		Temp Stability \pm Degrees error Per 1 Degree ΔT
	°F	°C	\pm °F	\pm °C	
Thermocouples B	105 to 3300	41 to 1816			
	150 to 500	66 to 260	28.0	16.0	4.00
	500 to 1000	260 to 538	6.0	3.3	1.00
	1000 to 3300	538 to 1815	3.0	1.7	0.40
E	-454 to 1832	-270 to 1000			
	-454 to -202	-270 to -130	36.0	20.0	1.40
	-202 to 1832	-130 to 1000	2.0	1.1	0.70
E (low)	-200 to 1100	-129 to 593	1.0	0.6	0.40
J	0 to 1600	-18 to 871	1.6	0.9	0.15
J (low)	20 to 770	-7 to 410	0.8	0.5	0.08
K	-320 to 2500	-196 to 1371	2.4	1.4	0.15
K (low)	-20 to 1000	-29 to 538	1.0	0.6	0.10
Ni-Ni Moly	32 to 2500	0 to 1371			
	32 to 500	0 to 260	1.5	0.8	0.21
	500 to 2500	260 to 1371	1.0	0.6	0.14
Nicrosil-Nisil	0 to 2372	-18 to 1200	2.1	1.2	0.20
R	0 to 3100	-18 to 1704			
	0 to 500	-18 to 260	4.0	2.2	0.50
	500 to 3100	260 to 1704	2.0	1.1	0.21
S	0 to 3100	-18 to 1704			
	0 to 500	-18 to 260	4.0	2.2	0.50
	500 to 3100	260 to 1704	2.0	1.1	0.21
T	-300 to 700	-184 to 371	1.6	0.9	0.15
T (low)	-200 to 600	-129 to 316	0.8	0.5	0.15
W5W26	0 to 4200	-18 to 2316			
	0 to 600	-18 to 316	2.8	1.6	1.00
	600 to 3600	316 to 1982	2.6	1.5	0.50
	3600 to 4200	1982 to 2316	3.2	1.8	0.20

Continued on next page

C.1 Overview, Continued

Table C-1 Reference Accuracy, continued

Types of Input Actuations	Range		Reference Accuracy*		Temp Stability ± Degrees error Per 1 Degree ΔT
	°F	°C	± °F	± °C	
RTD					
Platinum					
100 ohms**	-300 to 900	-184 to 482	0.8	0.5	0.15
100 ohms (low)	-130 to 392	-90 to 200	0.6	0.3	0.15
100 ohms (T)***	-238 to 482	-150 to 250	0.6	0.3	0.15
Linear					
Milliamperes dc	0 to 20 4 to 20	— —	16 μA 16 μA	—	0.011%/°F 0.011%/°F
Millivolts dc	0 to 10 0 to 100 0 to 200	— — —	10 μV 100 μV 200 μV	— — —	0.011%/°F 0.011%/°F 0.011%/°F
Volts dc	0 to 1 0 to 5 1 to 5 0 to 10	— — — —	1 mV 5 mV 4 mV 10 mV	— — — —	0.011%/°F 0.011%/°F 0.011%/°F 0.011%/°F

*Includes reference junction calibration of ±0.01 degrees using the standard “ice bath” method of calibration. Factory calibration at reference ±1.2°F. Note that factory calibration may have typical variations of ±150 microvolts or ±0.6 ohms for RTDs which means recalibration may be required to achieve stated accuracy.

**IEC Alpha = 0.00385

***IEC Alpha = 0.00391

Appendix D - Available 10-inch Charts

D.1 Single Range Charts

Introduction

Table D-1 lists the chart part numbers for the available 10-inch single range charts.

Table D-1 10-inch Single Range Chart Part Numbers

Chart Type	Range	Units	24 HR P/N 24001660-XXX	7 DAY P/N 24001661-XXX
B Thermocouple	0 to 1800	C	135	
J Thermocouple	-18 to 425	C	028	028
	-45 to +150	C	027	027
	-50 to +300	F	019	019
	0 to 150	C	070	070
	0 to 200	F	114	
	0 to 250	C	024	024
	0 to 300	F	002	002
	0 to 300	C	062	062
	0 to 400	F	012	006
	0 to 400	C	063	063
	0 to 500	F	013	007
	0 to 600	F	003	008
	0 to 800	F	014	009
	0 to 1000	F	015	010
	0 to 1200	F	004	011
	0 to 1600	F	018	018
	10 to 340	C	057	057
	10 to 76	C	030	030
	50 to 1400	F	029	029
	50 to 650	F	056	056
100 to 260	C	094		
150 to 750	F		150	
810 to 910	F		230	

Table D-1 continued on next page

D.1 Single Range Charts, Continued

Table D-1 10-inch Single Range Chart Part Numbers, Continued

Chart Type	Range	Units	24 HR P/N 24001660-XXX	7 DAY P/N 24001661-XXX
K Thermocouple	-18 to 1320	C	031	031
	0 to 200	C	086	
	0 to 400	F	053	053
	0 to 400	C	064	064
	0 to 500	C	205	
	0 to 600	C	059	059
	0 to 800	C	060	060
	0 to 1000	F	007	016
	0 to 1000	C	049	049
	0 to 1200	F	006	012
	0 to 1200	C	065	
	0 to 1600	F	016	013
	0 to 2000	F	005	014
	0 to 2400	F	009	015
	800 to 1000	F	227	
R Thermocouple	0 to 1600	C	017	017
	0 to 2500	F	025	025
	30 to 2900	F	032	032
	800 to 2500	C	089	
S Thermocouple	0 to 1600	C	066	
	0 to 3000	F	147	147
T Thermocouple	-250 to +150	F	042	042
	-130 to +410	F	033	033
	-100 to +100	C	069	069
	-90 to +210	C	034	034
	0 to 100	C		100
	0 to 150	C	103	201
	0 to 300	C		079
	75 to 200	C		058
	+125 to -1-5		098	
W5W26 Thermocouple	0 to 1800	C	157	

Table D-1 continued on next page

D.1 Single Range Charts, Continued

Table D-1 10-inch Single Range Chart Part Numbers, Continued

Chart Type	Range	Units	24 HR P/N 24001660-XXX	7 DAY P/N 24001661-XXX
Linear	-200 to +200			199
	-100 to +200		232	178
	-100 to +100	F	201	
	-85 to +190		179	
	-75 to +260		178	179
	-60 to +215		088	
	-50 to +50			218
	-40 to +10			142
	-30 to +170			087
	-30 to +100	C	210	
	-30 to +20	F	204	
	-18 to 94		035	
	-10 to 100			149
	-5 to 50	C	022	197/022
	0 to .1		170	170
	0 to .2		171	171
	0 to .5		172	172
	0 to .6			203
	0 to 1		211	202
	0 to 2	MG/L		217
	0 to 2	MGD	175	129
	0 to 5		074	074
	0 to 8		212	
	0 to 10		076	076
	0 to 10		168	168
	0 to 14		036	036
	0 to 14	PH	073	
	0 to 15		119	085
	0 to 20		071	071
	0 to 24	FEET		196
	0 to 25		095	095
	0 to 30		040	040
	0 to 40		110	041

Table D-1 continued on next page

D.1 Single Range Charts, Continued

Table D-1 10-inch Single Range Chart Part Numbers, Continued

Chart Type	Range	Units	24 HR P/N 24001660-XXX	7 DAY P/N 24001661-XXX	
Linear (continued)	0 to 45		078		
	0 to 50		104	051	
	0 to 55		130		
	0 to 70			075	
	0 to 80		120		
	0 to 100		001	001	
	0 to 120		054		
	0 to 150		180		
	0 to 200		010	004	
	0 to 300		050	050	
	0 to 350		037	037	
	0 to 400		011	005	
	0 to 600		052		
	0 to 750		223		
	0 to 800		137		
	0 to 1000		173		
	0 to 1200			108	
	0 to 1600			109	
	0 to 2000		F	202	
	0 to 2400		GPM		219
	0 to 2500			113	
	0 to 7000			123	
	0 to 8000			208	
	0 to 25000			111	
	0.2 to 2.0			176	176
	1.3 to 1.8				
	4 to 10			177	177
	5 to 9		PH		093
	10 to 20		METER	231	
	20 to 120			039	039
	40 to 70				125
	50 to 70				141
	50 to 250			008	003

Table D-1 continued on next page

D.1 Single Range Charts, Continued

Table D-1 10-inch Single Range Chart Part Numbers, Continued

Chart Type	Range	Units	24 HR P/N 24001660-XXX	7 DAY P/N 24001661-XXX
Linear (continued)	70 to 140		038	038
	100 to 200		132	
	100 to 300	F	131	
	100 to 600	F	140	
	1500 to 2500			
	2250 to 2500	F	209	
	1300 to 3600	F	203	
RTD-PT100 a=.00391	-200 to +100	F	044	044
	-125 to +375	F	020	020
	-100 to +50	C	091	
	-100 to +100	C	080	080
	-100 to +200	C	021	021
	-100 to +500	F	099	
	-85 to +190	C	047	
	-75 to +260	C	055	055
	-50 to +25	C	048	048
	-50 to +50	C	092	
	-35 to +75	C	023	023
	-30 to +170	F	087	087
	-25 to +125	C	045	045
	-20 to +30	F		117
	0 to -100	C		084
	0 to 60			161
	0 to 120	C	144	
	0 to 150	C	122	
	0 to 250	C	068	
	0 to 400	C	081	081
	49 to -95	C		083
	50 to 100	C	061	
	50 to 150	C	116	116
	50 to 250		096	
100 to 200	F	132		

Table D-1 continued on next page

D.1 Single Range Charts, Continued

Table D-1 10-inch Single Range Chart Part Numbers, Continued

Chart Type	Range	Units	24 HR P/N 24001660-XXX	7 DAY P/N 24001661-XXX
RTD-PT100 a=.00391 (continued)	120 to -140	F	082	
	180 to 30	F	121	
	250 to 300	F	106	
RTD-PT100 a=.00385	-100 to +100	C	080	080
	-40 to +60	C	067	067
	50 to 100		061	061
	50 to 120		134	
	0 to 250	C	068	
	0 to 400		081	081

D.2 Dual Range Charts

Introduction

Table D-2 lists the chart part numbers for the available 10-inch dual range charts.

Table D-2 10-inch Dual Range Chart Part Numbers

Calibration	Range 1	Range 2	24 HR P/N 24001660-XXX	7 DAY P/N 24001661-XXX
Linear/Linear	0 to 15	0 to 3,000,000	200	
	-100 to +200	35 to 0	600	600*
	0 to 200	63 to 0		602*
	0 to 2000	0 to 90		633*
	-18 to +94	35 to 0	603	
	-18 to +94	35 to 0		603
	-22 to +158	0 to 10	174*	
	0 to 50	0 to 100	606*	606
	0 to 60	0 to 100	138*	
	0 to 100	-30 to +70	601	
	0 to 100	0 to 14	621*	
	0 to 100	-30 to +70		601
	0 to 100	-80 to +20		653*
	40 to 140	30 to 40		148*
	50 to 150	0 to 100	097	
	50 to 150	20 to 0	609	
50 to 150	0 to 100		097	
Linear %/Linear PH	0 to 100	0 to 14		213
Linear/K T/C Deg. F	0 to 100	0 to 2000F	640*	
Linear/RTD Deg. C	0 to 100	-87 to +191C	145*	
Linear Deg. C/Linear	-40 to +150C	0 to 100 RH	660*	660*
Linear Deg. F/Linear %RH	0 to 120F	0 to 100	207	
Linear Deg. C/Linear %RH	-90 to +190C	0 to 100	197	
Linear Deg. C/Linear	-18 to +37C	0 to 100		620*
Linear Deg. F/Linear	-40 to +300F	0 to 100 RH	661*	661*
Linear Deg. F/K T/C Deg. F	0 to 3000F	0 to 2000F	645*	
Linear Deg. F/Linear	32 to 122F	0 to 100		151*
Linear Deg. F/Linear %RH	-125 to +375F	0 to 100	195	
	-125 to 375F	0 to 100		194
Linear Deg. F/PSI Linear	0 to 1400F	0 to 5000		
Linear Deg. C/Linear	-18 to +37C	0 to 100		637*

*minimum purchase required

Table D-2 continued on next page

D.2 Dual Range Charts, Continued

Table D-2 10-inch Dual Range Chart Part Numbers, Continued

Calibration	Range 1	Range 2	24 HR P/N 24001660-XXX	7 DAY P/N 24001661-XXX
Linear GPM/Linear PH	0 to 100	0 to 14		214
	0 to 250	0 to 14		200
Linear PSI/Linear GPM	0 to 15	0 to 7800		204
J T/C Deg. F/Linear	0 to 600F	0 to 2000 PSI	647*	
	0 to 300F	0 to 100	617*	617*
	0 to 300F	0 to 400	656*	
	0 to 400F	0 to 100	124*	
	0 to 400F	0 to 800	629*	
	0 to 600F	0 to 100	611*	
	0 to 300F	0 to 500	636*	
J T/C Deg. C/K T/C Deg. C	0 to 300C	0 to 1200C	143*	
	-18 to +315C	-18 to +1315C	112*	
J T/C Deg. F/J T/C Deg. C	95 to 455F	35 to 235C	026*	026*
J T/C Deg. F/J T/C Deg. F	1300 to 2000F	400 to 800F	649*	
	0 to 300F	0 to 1600F	651*	
J T/C Deg. F/K T/C Deg. F	0 to 300F	0 to 1500F	186	
	0 to 600F	0 to 2400F	604*	
K T/C Deg. F/Linear	-100 to +900F	0 to 10	635*	
	0 to 2000F	0 to 2	163*	
	500 to 2000F	0 to 1.5	127*	
T T/C Deg. C/Linear	-87 to +191C	0 to 100	153*	
T T/C Deg. F/Linear	50 to 250F	0 to 100	643*	
	-50 to +300F	0 to 100		631*
T T/C Deg. C/Linear	-100 to +100C	0 to 100		162*
	-80 to +180C	0 to 100	657*	
RTD Deg. F/Linear	100 to 300F	0 to 160	152*	
RTD Deg. C/Linear	-5 to +50C	0 to 100		102*
	-10 to +60C	0 to 100		616*
	-35 to +75C	0 to 100		101*
	-76 to +100C	35 to 0	607*	
	-50 to +100C	0 to 100	638*	638*
	-76 to +100C	35 to 0		607*
	-75 to +1800C	35 to 0	608*	
	-85 to +190C	0 to 100	154*	

*minimum purchase required

Table D-2 continued on next page

D.2 Dual Range Charts, Continued

Table D-2 10-inch Dual Range Chart Part Numbers, Continued

Calibration	Range 1	Range 2	24 HR P/N 24001660-XXX	7 DAY P/N 24001661-XXX
RTD Deg. C/Linear	-85 to +190C	0 to 100	659*	
	-5 to +50C	0 to 100		627*
	12 to 93C	0 to 1000	644*	
	50 to 150C	0 to 50	646*	
RTD Deg. F/Linear	-50 to +250F	0 to 1000		642*
	50 to 250F	0 to 100		626*
	0 to 300F	0 to 100	632*	
	100 to 300F	0 to 160	652*	
	-10 to +60F	0 to 100	616*	
RTD Deg. C/Linear	-100 to +100C	0 to 100	628*	628*
	-18 to +94C	0 to 100	155*	
RTD Deg. C/Linear PSIA	0 to 150C	0 to 25	222	
RTD Deg. C/RTD Deg. C	0 to 100C	50 to 120C		641*
	-23.3 to +93.3C	-87.2 to +177C	206	
RTD Deg. F/RTD Deg. F	14 to 122F	104 to 212F	619*	
RTD Deg. C/RTD Deg. C	-10 to +50C	40 to 100C	618*	

*minimum purchase required

Index

A

AC line power, *11, 35*
Accuracy, *159*
Alarm Function Failure Symptoms, *125*
Alarm Output, *26*
Alarm setpoints, *90*
Alarms group prompts, *67*
Ambient Temperature, *24*
Automatic local mode, *87*
Automatic mode, *88*

B

Basic recorder components without options, *141*
Burnout, *12*
Burnout protection, *56*

C

CAL, *70*
Capacitive and inductive coupling, *150*
CE Conformity (Europe), *1*
CE Conformity special conditions, *23*
CE Conformity Special Conditions (Europe), *32*
Chart, *96*
Chart group prompts, *51*
Chart Motor, *129*
Chart Plate Assembly, *140*
Chart plate components, *74*
Chart Rotation Failure Symptoms, *121*
Chart step pattern, *76*
Chart time, *77*
Circuit-breaker, *35*
Coil Voltage vs Resistor Voltage, *156*
Color, *25*
CONF, *70*
Configuration Record Sheet, *71*
Configuration selections, *10*
Contact Noise Suppression, *157*
Control /Alarm Function Summary, *19*
Control algorithm, *61*
Control group prompts, *60*
Control output direction, *62*
Control Output Setup, *15*
Control output setup procedure, *20*
Control setpoint, *89*
Current Proportional, *25*
Current Proportional Output, *108*
Current Proportional Output Failure, *123*
Current simplex, *60*
Cycle group prompts, *66*
Cycle time, *66*
Cycle time for relay 2, *66*

D

DC Load Noise Suppression, *158*
Deadband, *63*
Decimal point location, *53*
Diagnostic error messages, *85*
Diagnostic tests, *78*
Digital Displays, *24*
Dimensions, *27*
DIP Switch and Jumper Locations, *10*
DIP Switch and Jumper Locations for Actuation Selections, *14*
DIP switch S1, *13*
Direct acting control, *62*
Display and key test., *79*
Display Failure Symptoms, *123*
Displays, *6*
Door assembly, *138*

E

Electrical considerations, *32*
Electrical isolation, *154*
Electrical noise, *32, 149*
Electrical Pen Alignment, *133*
Electromagnetic interference, *149*
Erratic Pen Movement Symptoms, *122*
Error Message Prompts, *117*

F

Failsafe, *115*
Failsafe output value, *63*
Ferrite filter locations (CE Mark), *34*
Filter, *55*
Full, *70*

G

Gain, *64*
Gain 2, *65*
Grounding, *32*

H

Hardware components, *4*
Heat/Cool prompts, *147*
High output limit, *62*
Hysteresis, *63*

Index

I

Ice Bath, *102*
Impedance coupled noise, *150*
Indicators, *6, 83*
Ink cartridge, *95*
Input 1 Wiring, *37*
Input 2 Wiring, *39*
input actuation, *13*
Input actuation type, *54*
Input Actuators, *24*
Input bias, *55*
Input Calibration Procedure, *105*
Input Connections, *99*
Input Filter, *24*
Input high range value, *55*
Input jumper locations, *13*
Input low range value, *55*
Input Span, *24*
Installation, *23*;
 Operating limits, *24*;
 Preinstallation information, *23*

J

Jumper locations on the Optional Control Output
 printed circuit board, *18*
Jumper W1, *11*
Jumpers W3 or W4, *12*

K

Key error, *79*
Keyboard Printed Circuit Board, *131*
Keys, *7*
Knockout locations, *28*

L

Line voltage, *35*
Lock, *70*
Lockout group prompts, *70*
Low output limit, *63*
Lower Display Key, *84*

M

Main Printed Circuit Board, *130*
Maintenance, *95*
Manual mode, *87, 88*
Manual reset, *65*
Manual Tuning, *143*
Manual tuning formulas, *145*

Manual Tuning Procedure, *144*
Mechanical pen alignment, *132*
Mechanical Shock, *24*
Minutes per repeat, *63*
Model Number Interpretation, *3*
Modes of Operation, *25*
Monitoring Your Recorder, *82*
Mounting:
 Overall dimensions, *27*
Mounting flush, *29*
Mounting on surface, *30*
Mounting Position, *24*
Mounting the Control Output PCB, *16*

N

Noise, *149*
Noise rejection, *151*

O

On-Off, *25*
ON/OFF, *61*
Operating limits, *24*
Operating Mode Definitions, *87*
Operating parameters, *84*
Operation, *73*
Operator interface, *6, 82*
Output algorithm, *60*
Output Group Function Prompts, *59*
Output relay action, *22*

P,Q

Parts lists, *137*
PD with Manual Reset, *62*
Pen group prompts, *52*
Pen life, *94*
Pen Trace Failure Symptoms, *121*
Physical considerations, *27*
PID A, *61*
Power Consumption, *24*
Power supply mains, *35*
Power Supply Output Wiring, *41*
Power up controller mode recall, *62*
Power-up tests, *115*
Procedure, *132*
Prompt hierarchy, *46*
Proportional band, *63, 64*
Proportional band 2, *65*
Proportional band units, *63*
Protective bonding, *32*

Index

R

Radio frequency interference, *149*
Rate 2, *65*
Rate action, *64*
Rate of integration, *57*
Recorder components associated with options, *142*
Recorder failure symptoms, *120*
Relative Humidity, *24*
Relay, *2 Action*
Relay duplex, *60*
Relay Output Failure Symptoms, *124*
Relay Output Wiring, *43*
Relay Simplex, *60*
Repeats Per Minute, *63*
Replacement Procedures, *127*
Replacing the
 Chart, *96*
 Chart Motor, *129*
 Display And Keyboard PCB, *131*
 Ink Cartridge, *95*
 Main Printed Circuit Board, *130*
 No. 1 Pen Arm, *127*
 No. 2 Pen Arm, *128*
 Servo Plate, *129*
Reproducibility, *24*
Reference accuracy, *159*
Reset, *65*
Reset Units, *63*
Resetting the totalizer, *91*
Restore factory or field calibration, *92*
Reverse acting control, *62*
RTD Inputs, *103*

S

S1 switch positions and settings, *13*
Safety Requirements for Electrical Equipment, *32*
Sampling Rate, *24*
Self diagnostics, *113*
Self-test, *75*
Servo Plate, *129*
Set point low limit, *62*
Set Up prompts, *46*
Setpoint high limit, *62*

Setup tasks, *9*
Shock hazard warning, *73, 111*
Signal and power line separation, *151*
Signal reference jumper locations, *13*
Software version, *114*
Span Step Response Time, *24*
Start-up, *77*
Start-up procedure, *80*
Status tests, *116*
Suppression at the source, *151*
Suppression filters, *34*
Surge suppressers'',*155*
Symbol Definitions, *iii*

T,U

Temperature Units, *53*
Thermocouple inputs using an ice bath, *102*
Time Proportional, *25*
Time Proportional Duplex, *25*
Totalizer group prompts, *57*
Totalizer Scale Factor, *58*
Transformer for Digital Equipment, *154*
Transient Suppression in Inductive Coils, *156*
Transmitter Supply Voltage, *26*
Troubleshooting / Service, *111*
Tuning, *143*
Tuning group prompts, *64*

V

Vibration, *24*
Visual failure symptoms, *119*
Voltage and Resistance Equivalents, *98*

W,X,Y,Z

WARNING—SHOCK HAZARD, *73, 97, 111*
Weight, *25*
Wire bundling, *152*
Wiring, *33*

Index

www.DataSheet4U.com

READER COMMENTS

Honeywell's IAC Automation College welcomes your comments and suggestions to improve future editions of this and other publications.

You can communicate your thoughts to us either by **mail** using this form, or a **toll-free telephone** call.

BY TELEPHONE: In the U.S.A. use our toll-free number 1*800-822-7673 (available in the 48 contiguous states except Arizona; in Arizona dial 1-602-863-5558).

BY MAIL: Use this form; detach, fold, tape closed, and mail to us. We would like to acknowledge your comments; please include your complete name and address.

www.DataSheet4U.com

Title of Publication: **DR4200 EV Circular Chart Recorder Product Manual**

Publication Number: **44-01-25-09D**

Issue Date: **6/98**

Writer: **Dan O'Connor**

COMMENTS: _____

RECOMMENDATIONS: _____

NAME _____ DATE _____
TITLE _____
COMPANY _____
ADDRESS _____
CITY _____ STATE _____ ZIP _____

(If returning by mail, please tape closed; Postal regulations prohibit use of staples.)

Communications concerning technical publications should be directed to:

Automation College
Industrial Automation and Control
Honeywell Inc.
2820 West Kelton Lane
Phoenix, Arizona 85023

FOLD

FOLD

From: _____



NO POSTAGE
NECESSARY
IF MAILED
IN THE USA

BUSINESS REPLY MAIL
FIRST CLASS PERMIT NO. 4332 PHOENIX, ARIZONA

POSTAGE WILL BE PAID BY

Honeywell

**Industrial Automation and Control
2820 West Kelton Lane
Phoenix, Arizona 85023**

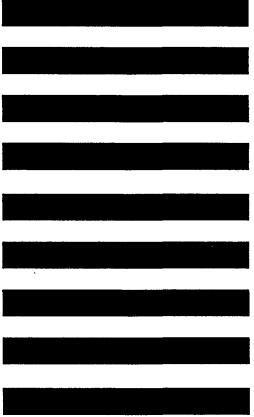

Cut Along Line

Attention: Manager, Quality

FOLD

FOLD

Industrial Automation and Control
Honeywell, Inc.
1100 Virginia Drive
Fort Washington, Pennsylvania 19034

Honeywell

Helping You Control Your World



**Made from 50% recycled
fibers that contain 20%
post-consumer waste.**