

DRA808M
30dBm Wireless Voice Transceiver Module

V1.11

Features:

- Frequency Range: 400~470MHz
- Tx/Rx frequency independent
- Channel space: 12.5/25KHz
- Configurable multi-channels
- Sensitivity: -122dBm
- Output power: +27/30dBm
- 38 CTCSS codes
- 6 volume levels
- 8 squelch levels
- UART interface
- Temperature: -20°C ~+60°C
- TX current: 450/750mA
- Supply voltage: 3.3~4.5V

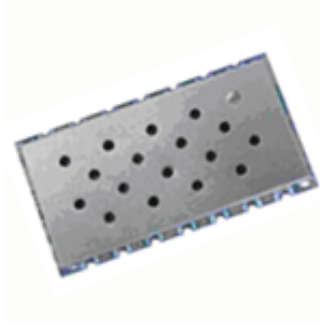

Applications

- Portable walkie-talkie
- Outdoor sports products
- Audio monitor system
- Building security system

DESCRIPTION

DRA808M is a type of compact wireless voice transceiver module. It integrates high speed microcontroller, high performance wireless transceiver IC, high power PA, audio process and squelching circuits. It provides standard UART interface which users can easily configure appropriate parameters for different applications. Users can easily construct a walkie-talkie system by connecting microphone, audio PA and speaker.

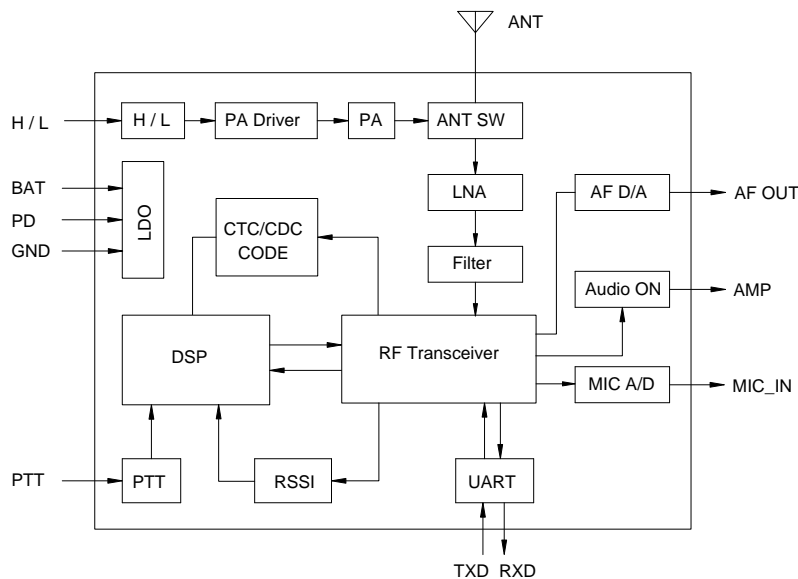

Figure 1: DRA808M Functional Block

PIN FUNCTIONS

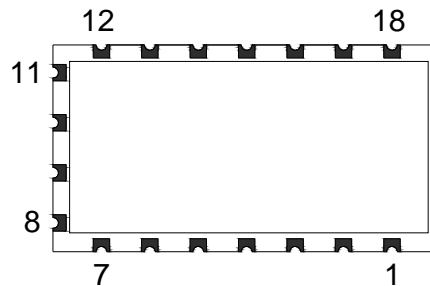

Figure 2: DRA808M Pin Layout

PIN	Name	Function	Description
1	SQ	Output	Squelch detection.. Low→ Audio amplifier on
2	NC	---	No connection
3	AF_OUT	Output	Audio output pin.
4	NC	---	No connection
5	PTT	Input	Tx/Rx control pin: Low→TX; High→ RX
6	PD	Input	Power saving control pin: Low→sleep mode; High→normal mode
7	H/L	Input	RF Power Selection: Low→0.5W; float ed→1W
8	VBAT	Power	Power supply
9	GND	Ground	Ground (0V)
10	GND	Ground	Ground (0V)
11	NC	---	No connection
12	ANT	---	Antenna port. 50 Ohm impedance
13	NC	---	No connection
14	NC	---	No connection
15	NC	---	No connection
16	RXD	Input	UART input, TTL level
17	TXD	Output	UART output, TTL level
18	MIC_IN	Input	MIC input

Table 1: DRA808M Pin Functions

ELECTRICAL SPECIFICATIONS

Symbol	Parameter (condition)	Min.	Typ.	Max.	Units
VCC	Supply Voltage	3.3	4.0	4.5	V
Freq	Frequency range	400		470	MHz

Temp	Operating temperature range	-20	25	60	°C
IDD_R	Current in receive mode @ Audio amplifier on @ Audio amplifier off		60		mA
			55		mA
IDD_T (1)	Current in transmit mode @ Low Power Mode @ High Power Mode		400	450	mA
			700	750	
IDD_S	Current in sleep mode		30		uA
CH_w	Channel Space @ Narrow band @ Wide band		12.5		kHz
			25		kHz
T_sw	Tx/Rx switching time		20		mS
T_IN	Module initializing time		300	500	mS
Z_ANT	Antenna Impedance		50		Ohm

Table 2: DRA808M Electrical Specifications

RECEIVE CHARACTERISTICS

Symbol	Parameter (condition)	Min.	Typ.	Max.	Units
Freq	Frequency range	400		470	MHz
Sen.	Receiver sensitivity @ 12dB SINAD	-120	-122		dBm
Sen_sq	Squelch function sensitivity		-120		dBm
SNR_R	S/N in receive mode @ 1.5KHz Fdev.	45	50		dB
ACS	Adjacent channel selection @ CH_w = 12.5 KHz	55	60		dB
IR	Inter-modulation rejection @ CH_w = 12.5 KHz	55	60		dB
SPR	Spurious emission rejection @ CH_w = 12.5 KHz	55	60		dB
AF_ZOUT	Audio output impedance		200	400	Ohm
AF_AMP	Audio signal amplitude @ 1KHz		1		Vpp
AF_RD	Audio signal distortion @ 1KHz		1	3	%
AF_FR	Frequency response @ 300Hz @ 500Hz @ 1000Hz @ 2500Hz		-30		
			+4		
			0		
			-10		
VCO_L	VCO leak in receive mode @ LNA port			-50	dBm

Table 3: DRA808M Receive Characteristics

TRANSMIT CHARACTERISTICS

Symbol	Parameter (condition)	Min.	Typ.	Max.	Units
Freq	Frequency range	400		470	MHz
Pout	Output power @ Low Power Mode @ High Power Mode		26 29	27 30	dBm
Fdev	Max. Frequency deviation @ Narrow band @ Wide band			2.5 5	KHz
Sen_MOD	Modulation Sensitivity @ 1KHz at 2.5KHz Fdev.	8	12	16	mV
AF_TD	Audio modulation distortion@1KHz at 2.5KHz Fdev.		2	5	%
MOD	Modulation features @ 300Hz		-20		dB
	@ 500Hz	-5	-6	-9	dB
	@ 1000Hz		0		dB
	@ 2500 Hz	3	6	9	dB
SNR_T	S/N in Transmit mode @1KHz at 2.5KHz Fdev.	38	40	45	dB
Fdev_c	CTCSS frequency deviation	0.35	0.5	0.75	KHz
CS	Carrier suppression		-60		dBc
IM3	third-order intermodulation suppression		-60		dBc
ACP	Adjacent channel power @12.5KHz offset		-60		dBc
SE	Spurious emission		-36		dBc

Table 4: DRA808M Transmit Characteristics

ABSOLUTE MAXIMUM RATINGS

Symbol	Parameter	Min.	Max.	Units
VCC	Supply Voltage	-3.3	5	V
V _{IN}	Input voltage	-0.3	VCC+0.3	V
I _{IN}	Input current	-10	10	mA
T _{ST}	Storage temperature	-40	90	°C

Table 5: DRA808 Maximum Ratings

PARAMETERS SETTING

Some parameters of DRA808M modules can be changed by following the commands in this section, which provide flexibility for designers to optimize related parameters to achieve the best performance. DRA808M modules use standard UART interface to communicate with

microcontrollers or other hosts. The default data format is: 8 data bits, 1 stop bit, no parity and 9600 kbps data rate. All commands in ASCII codes start with “AT” and end with <CR><LF>.

1 Handshake Command

Description: It is used to check if the module works normally. DRA808M module will send back response information when it receives this command from the host. If the host doesn't receive any response from module after three times of continuously sending this command, it will restart the module.

Format: `AT+DMOCONNECT <CR><LF>`

Module response: `+DMOCONNECT: 0 <CR><LF>`

2 Group Setting Command

Description: This command is used to configure a group of module parameters.

Format: `AT+DMOSETGROUP=GBW,TFV,RFV,CXCSS,SQ <CR><LF>`

Module response: `+DMOCONNECT: X<CR><LF>`

- **GBW:** Channels space. 0→12.5k; 1→25k
- **TFV:** Transmit frequency. Range: 400.0000~470.0000MHz
- **RFV:** Receive frequency. Range: 400.0000~470.0000MHz. The frequency should be the times of 12.5KHz or 25KHz.
- **CXCSS:** CTCSS value (00~38). 00→ no code; 01~38→ effective code
- **SQ:** Squelch level (0~8). 0→ monitor mode which can't be used in scanning mode.
- **X:** Configuration result. 0→ succeeded; 1→ data out of range.

Example:

Command: `AT+DMOSETGROUP=0,415.1250,415.1250,12,4 <CR><LF>`

Response: `+DMOSETGROUP:0<CR><LF>`

3. Volume Command

Description: This command is used to adjust the volume of module.

Format: `AT+DMOSETVOLUME=X <CR><LF>`

Module response: `+DMOSETVOLUME: X<CR><LF>`

- X in command: Volume range (1~6).
- X in response: 0→ succeeded; 1→failed.

TYPICAL APPLICATION CIRCUIT

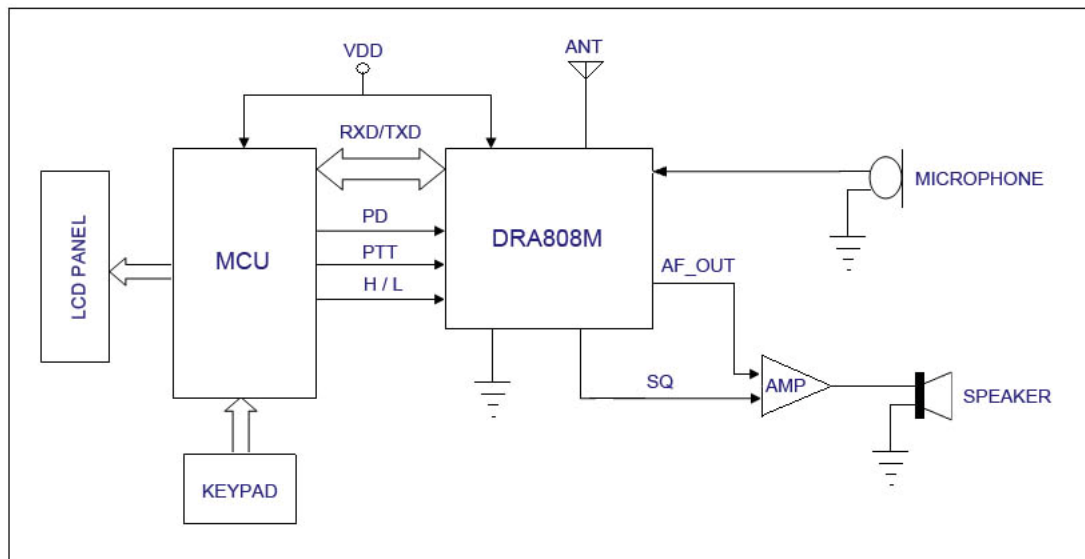

Figure 3: DRA808M Application Circuit

MECHANICAL DATA

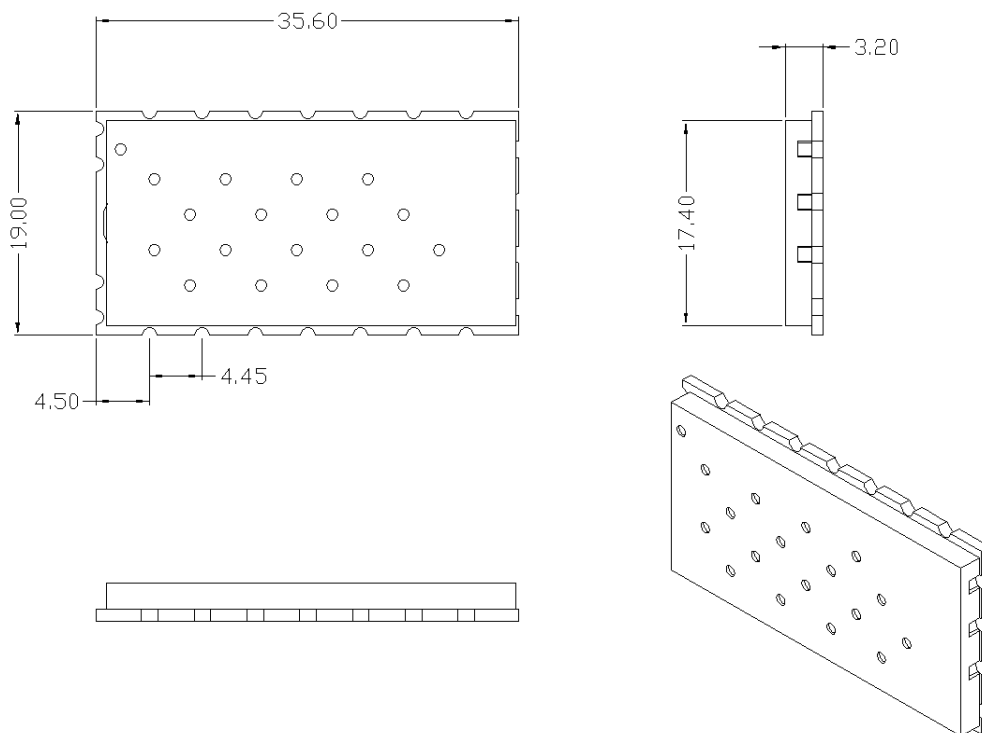

Figure 4: DRA808M Mechanical Dimension

ORDERING INFORMATION

DRA818U is the successive version of DRA808M which is based on RDA1845. Comparing to DRA808M, CDCSS and audio control AT command are added, which provides more flexibility for the users who need to process audio signal more precisely. DRA818V is the VHF band version of DRA818U.

Part Name	Frequency Range	RFIC	Dimension
DRA808M	400~470MHz	RDA1845	Compatible
DRA818U	400~470MHz	RDA1846	Compatible
DRA818V	134~174MHz	RDA1846	Compatible

Table 6: Ordering Information

<p>Dorji Applied Technologies A division of <i>Dorji Industrial Group Co., Ltd</i></p> <p>Add.: Xinchenuayuan 2, Dalanganlu, Longhua, Baoan district, Shenzhen, China 518109</p> <p>Tel: 0086-755-28156122 Fax.: 0086-755-28156133 Email: sales@dorji.com Web: http://www.dorji.com</p>	<p>Dorji Industrial Group Co., Ltd reserves the right to make corrections, modifications, improvements and other changes to its products and services at any time and to discontinue any product or service without notice. Customers are expected to visit websites for getting newest product information before placing orders.</p> <p>These products are not designed for use in life support appliances, devices or other products where malfunction of these products might result in personal injury. Customers using these products in such applications do so at their own risk and agree to fully indemnify Dorji Industrial Group for any damages resulting from improper use.</p>
---	---