

---

**DRF4463F**  
**20dBm ISM RF Transceiver Module**

**V1.21**

---

**Features:**

- Frequency Range: 433/868MHz
- Modulation: (G)FSK/4(G)FSK/(G)MSK
- SPI Data Interface
- Sensitivity: -126dBm
- Output Power: +20dBm
- Data Rate: -0.1~1000 kbps
- Digital RSSI
- Wake-up Timer
- 64/128 bytes TX/RX FIFOs
- Integrated Voltage Regulator
- Frequency Hopping Capability
- Temperature sensor and 8-bit ADC
- Working Temperature: -20°C ~+60°C
- Standby current:  $\leq 1\mu\text{A}$
- Supply voltage: 1.8~3.6V

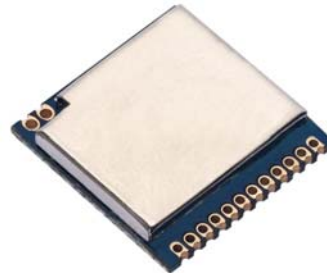

**Applications**

- Remote Control
- Smart metering
- Home Automation
- Personal data logger
- Wireless sensor network
- Remote keyless entry
- Wireless PC peripherals

**DESCRIPTION**

DRF4463F is a type of low cost RF front-end transceiver module based on SI4463 from Silicon labs. It keeps all the advantages of RFIC SI4463 but simplifies the circuit design. The high sensitivity (-126dBm) and 20dBm high power output make the module suitable for most short range applications.

DRF4463F module consists of RFIC Si4463, thin SMD crystal and antenna matching circuit. The antenna port is well matched to standard 50 Ohm impedance. Users don't need to spend time in RF circuit design and choose suitable antennas for different applications. DRF4463F operates at 1.8~3.6V with extra low standby current which makes it suitable for battery powered-up applications.

**PIN FUNCTIONS**

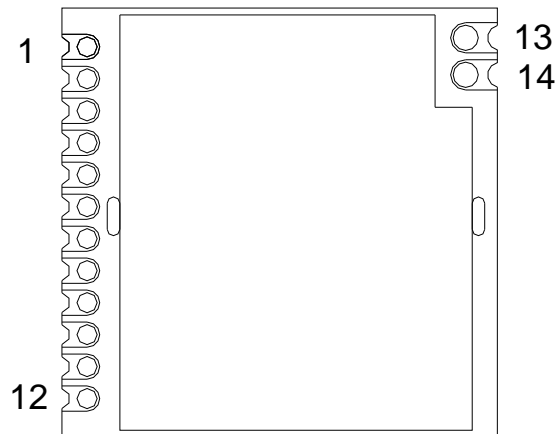

**Figure 1: DRF4463F Pin Layout**

PIN	Name	Function	Description
1	GND	Ground	Ground (0V)
2	----	----	Empty
3	GPIO0	Input/Output	General purpose I/O pin
4	GPIO1	Input/Output	General purpose I/O pin
5	VCC	Power	Normal 3.3V
6	SDO	Output	SPI data output pin
7	SDI	Input	SPI data input pin
8	SCLK	Input	SPI data clock pin
9	nSEL	Input	SPI select pin
10	nIRQ	Output	Interrupt status output pin
11	SDN	Input	Shutdown Input pin
12	GND	Ground	Ground (0V)
13	ANT	Output	50 Ohm Impedance
14	GND	Ground	Ground (0V)

**Table 1: DRF4463F Pin Functions**

**ELECTRICAL SPECIFICATIONS**

Symbol	Parameter (condition)	Min.	Typ.	Max.	Units
VCC	Supply Voltage	1.8		3.6	V
Temp	Operating temperature range	-20	25	60	°C
Freq	Frequency range	403	433	463	MHz
RES <sub>RSSI</sub>	RSSI resolution		±0.5		dB
I <sub>DD_R</sub>	Current in receive mode @ High performance mode @Low power mode		13.5 10.7		mA
I <sub>DD_T</sub> <sup>(1)</sup>	Current in transmit mode @ 433Mhz @ 868Mhz		85 95		mA
I <sub>DD_S</sub>	Current in sleep mode.			0.1	uA
P <sub>out</sub>	Max. output power @ 433Mhz @ 868MHz		19.5 19		dBm
Sen. <sup>(2)</sup>	Receiver sensitivity @ 433Mhz		-126		dBm
DR <sub>FSK</sub>	FSK data rate	0.123		1000	Kbps
Z <sub>ANT</sub>	Antenna Impedance		50		Ohm

**Table 2: DRF4463F Electrical Specifications**

**Notes:**

- (1) Transmit current is tested at the Max. output power at 3.3V. The actual output power mainly depends on the setting of register PA\_PWR\_LVL (0x2201) in [EZRADIOPRO API Documentation](#) ). The largest value of 0x7F means the Max. output power without attenuation. The register can be set in 128 different values so each step of value is not linear to the output power of module. Datasheet of si4463 shows the diagram of TX Power vs. PA\_PWR\_LVL in 900MHz. For register value 0x1E, the output power is about 14dBm and for 0x14 the output power is about 10dBm. Considering the insertion loss of matching circuit between si4463 and DRF4463F antenna port is about 0.5~1dB, the actual output powers of DRF4463F at 0x1E and 0x14 are 13~13.5dbm and 9~9.5dBm. The output power also are affected by working voltage and temperature. Higher working voltage (>3.3V) and lower working temperature can improve the max. output power so users can refine the register value of PA\_PWR\_LVL to obtain the legal output power according to corresponding radio rules and regulations
- (2) Sensitivity is measured at DR<sub>FSK</sub> =500 bps and F<sub>DEV</sub> =±3 kHz

**ABSOLUTE MAXIMUM RATINGS**

Symbol	Parameter	Min.	Max.	Units
VCC	Supply Voltage	-0.3	3.6	V
VI	Input voltage	-0.3	VCC+0.3	V
VO	Output voltage	-0.3	VCC+0.3	V
Tst	Storage temperature	-55	125	°C

**Table 3: DRF4463F Maximum Ratings**

**TYPICAL APPLICATION CIRCUIT**

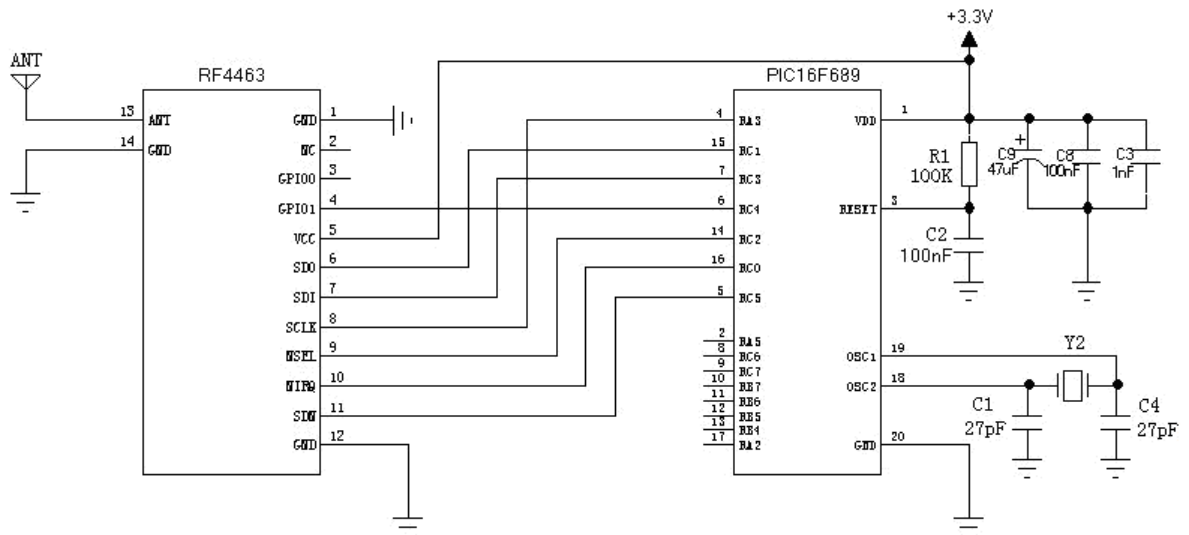

**Figure 2: Application Circuit**

**MECHANICAL DATA**

Unit: mm Tolerance:  $\pm 0.2$ mm (unless noted)

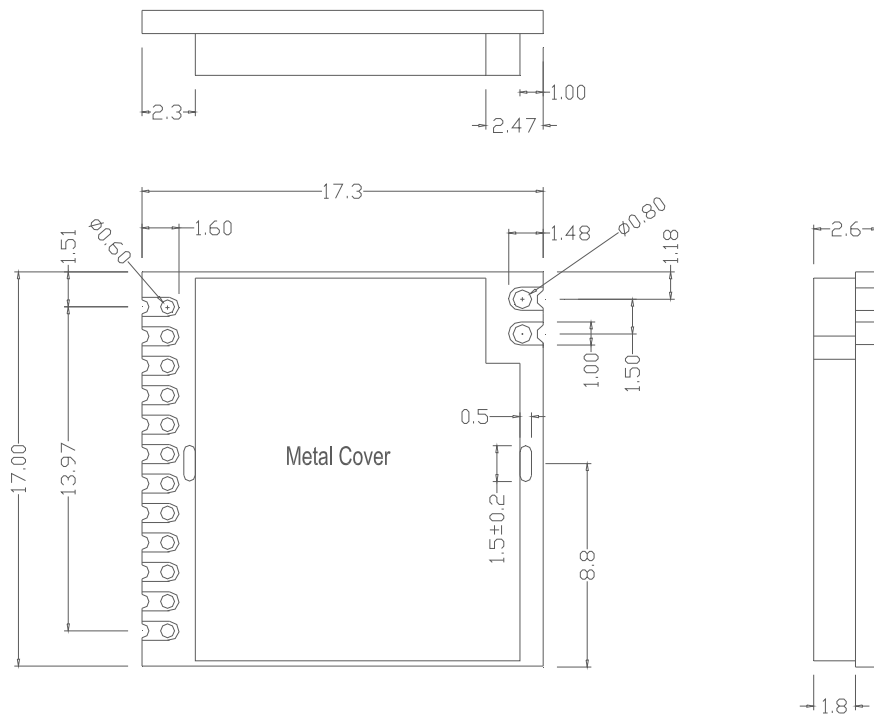

**Figure 3: Mechanical Dimension**

**ORDERING INFORMATION**

**DRF 4463 F 20 — 043 S**

- ① ② ③ ④ ⑤ ⑥

Num	Symbol	Meaning
①	RF module	RF (G)/FSK / GFSK module
②	IC Type	SI4463
③	Module Function	RF front-end module
④	Power	20dBm output power
⑤	Freq. Band	043: 433MHz 086:868MHz
⑥	Package	SMD package

**Table 4: Ordering Information**

---

**REFERENCE DOCUMENTS**

1. [Si4463 Datasheet](#)
2. [EZRadioPRO API Documentation](#)

<p>orji Applied Technologies A division of <i>Dorji Industrial Group Co., Ltd</i></p> <p>Add.: Xinchenuayuan 2, Dalangnanlu, Longhua, Baoan district, Shenzhen, China 518109</p> <p>Tel: 0086-755-28156122 Fax.: 0086-755-28156133 Email: <a href="mailto:sales@dorji.com">sales@dorji.com</a> Web: <a href="http://www.dorji.com">http://www.dorji.com</a></p>	<p>Dorji Industrial Group Co., Ltd reserves the right to make corrections, modifications, improvements and other changes to its products and services at any time and to discontinue any product or service without notice. Customers are expected to visit websites for getting newest product information before placing orders.</p> <p>These products are not designed for use in life support appliances, devices or other products where malfunction of these products might result in personal injury. Customers using these products in such applications do so at their own risk and agree to fully indemnify Dorji Industrial Group for any damages resulting from improper use.</p>
---	---