

Customer Name : (주) 하이디스플레이

Date : 2011. 02. 22.

## SPECIFICATION FOR APPROVAL

Part Name : CCFL INVERTER



Customer Part No. :

DS-Plus Part No. : DS-1307WA (Voltage Control Dimming)

Approval Sign

Please Return 1 Copy After Approved

**DS -Plus Inc.**

PREPARED	APPROVAL
	

**Table of content**

<u>Contents</u>	<u>Page</u>
1. Revision history	3/12
2. Features	4/12
3. Applications	4/12
4. Absolute maximum ratings	4/12
5. Recommend operating conditions	5/12
6. Electrical characteristics	5/12
7. Functional pin description	6/12
8. Mechanical dimensions	6/12
9. Test circuit	7/12
10. Heat shock test	7/12
11. Notation of lot number	8/12
12. Packing	8/12
13. Parts list	9/12
14. Circuit diagram	10/12
15. PCB lay-out	11/12
16. Material list	12/12

**1. Revision history**

<b>No .</b>	<b>DATE</b>	<b>REVISION</b>	<b>DESCRIPTION</b>

## **2. Features**

- High efficiency
- Drive 2 lamps with one module
- Nominal current 7.5 mArms for each lamp
- 10.8 to 13.2V input voltage operation
- Accurate and stable output current regulation
- Voltage Control Dimming
- All lamp operation frequency synchronized
- Long lamp life with soft start
- Low sleep current
- Single sided PCB layout
- High efficiency
- Built- in fuse
- Low EMI and spurious noise

## **3 Applications**

- 15~ 22" LCD TV & Monitor

## **4. Absolute maximum ratings**

Input supply voltage ( $V_{IN}$ )	-----	- 0.3V to 14.0V
Output voltage, no load	-----	Internally limited to zero volt
Output current for each lamp( $I_O$ )	-----	9.0mArms
Output power (per lamp)	-----	7.0W
Sleep & bright adjust signal voltage ( $V_{SLEEP}$ , $V_{BRT}$ )	-----	- 0.3V to $V_{IN}$
Ambient operating temperature	-----	0 °C to 50 °C
Storage temperature range	-----	- 30 °C to 80 °C
Operating & storage humidity	-----	10 % to 85 %

**5. Recommended operating conditions** (R.C.)

Parameter	Symbol	Recommendation			Units
		Min	R.C.	Max	
Input supply voltage	$V_{IN}$	10.8	12.0	13.2	V
Full bright lamp current	$I_{O(MAX)}$	6.5	7.5	8.0	mArms
Brightness control voltage range	$V_{BRT}$	5.0		0	V
Lamp on/off control voltage	$V_{SLEEP}$	3.0	5.0	7.0	V
Lamp operating voltage	$V_O$		700		Vrms
Operating ambient temperature range	$T_A$	0		50	°C

**6. Electrical characteristics**

Parameter	Symbol	Conditions*	Specification*			Unit
			Min	Typ	Max	
Input supply voltage	$V_{IN}$		10.8	12.0	13.2	V
Input current	$I_{IN}$	$V_{IN}=12V, V_{BRT}=0V$	1.0	1.2	1.4	A
Full bright lamp current	$I_{O(MAX)}$	$V_{IN}=12V, V_{BRT}=0V$	6.5	7.5	8.0	mArms
Minimum lamp current	$I_{O(MIN)}$	$V_{IN}=12V, V_{BRT}=5.0V$	1.5	2.5	3.5	mArms
Operating frequency	$F_O$	$V_{IN}=12V, V_{BRT}=0V$	45	50	55	KHz
Dimming ratio		$V_{IN}=12V, V_{BRT}=0$ to 5.0V		2 :1		
Sleep current	$I_{IN}$	$V_{IN}=12V, V_{BRT}=0V$			10	mA
Efficiency		$V_{IN}=12V, V_{BRT}=0V$	80			%

\* At the reference 20" Wide LCD-Module(LTM200KT01) of Samsung

**7. Functional pin description**

- CN1 Connector : 12505WR- 12A00 (YEONHO or Equivalent)
- CN1- 1,2,3  $V_{IN}$  (DC input ; 12.0V)
  - CN1- 4,5,7,8,10,12  $G_{ND}$  (Power supply return)
  - CN1- 9  $V_{SLEEP}$  (Lamp On/Off control ; Off at Low , On at High)
  - CN1- 11  $V_{BRT}$  (Bright adjust ; 0 to 5.0V)
  - CN1- 6 NC
- CN2,3 Connector : 35001WR- 02A00 (YEONHO or Equivalent)
- CN2,3- 1 High voltage
  - CN2,3- 2 Lamp current return

**8. Mechanical dimensions**

Tolerance :  $\pm 0.5$   
Unit : mm

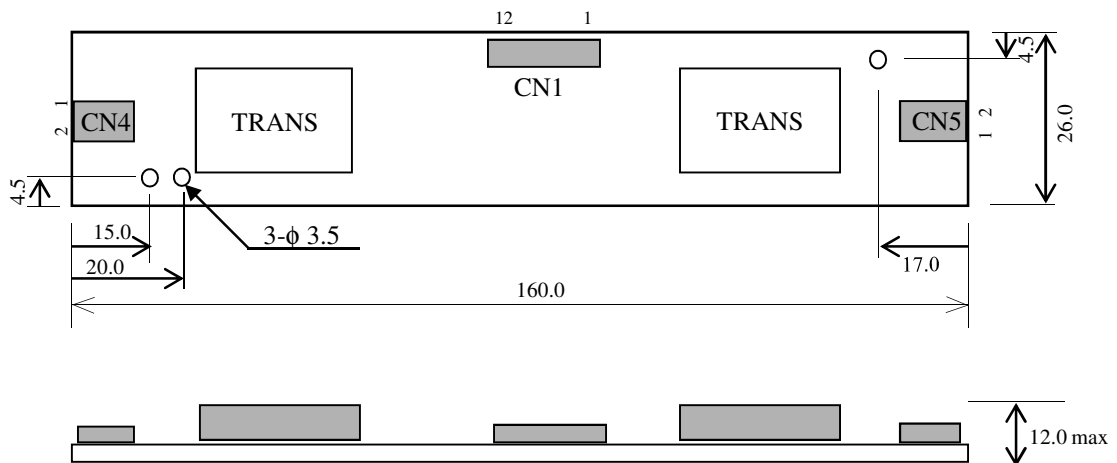

**9. Test circuit**

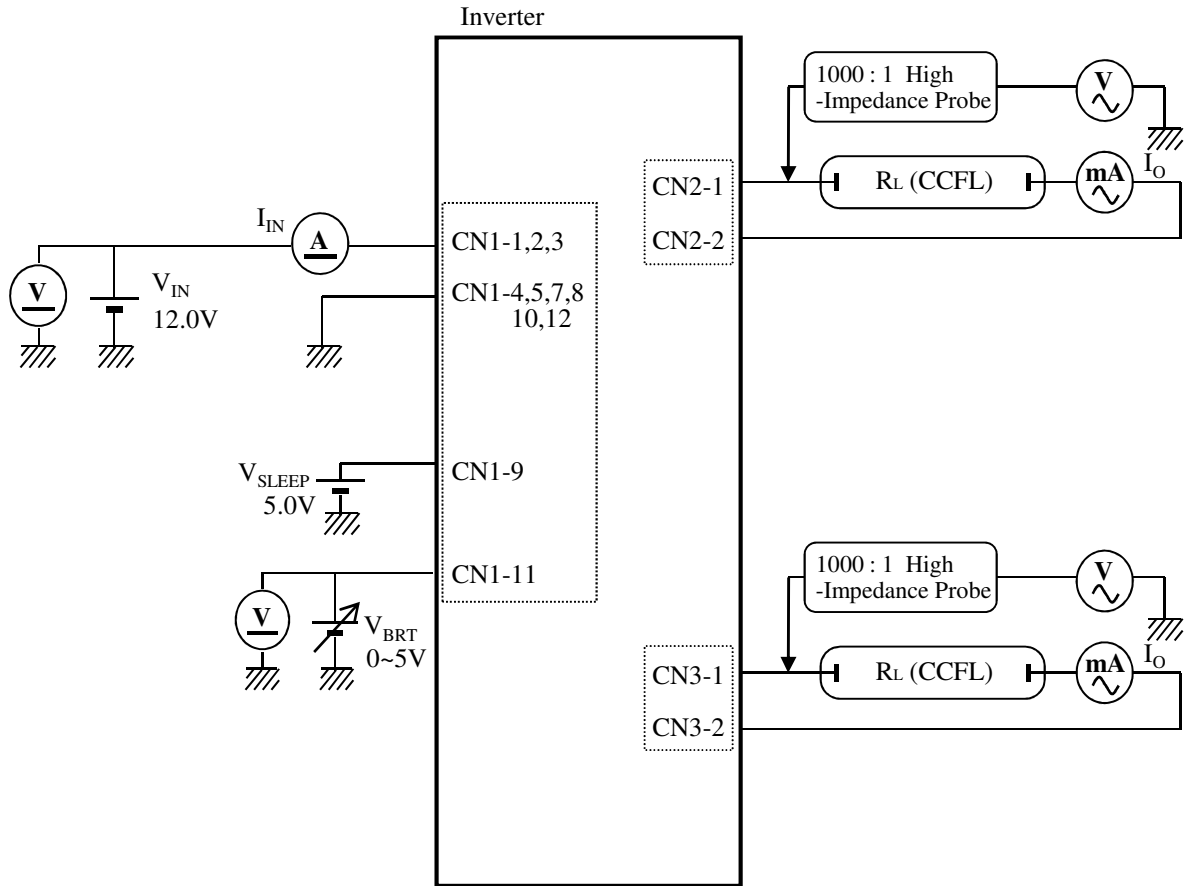

**10. Heat shock test**

20 cycles of test

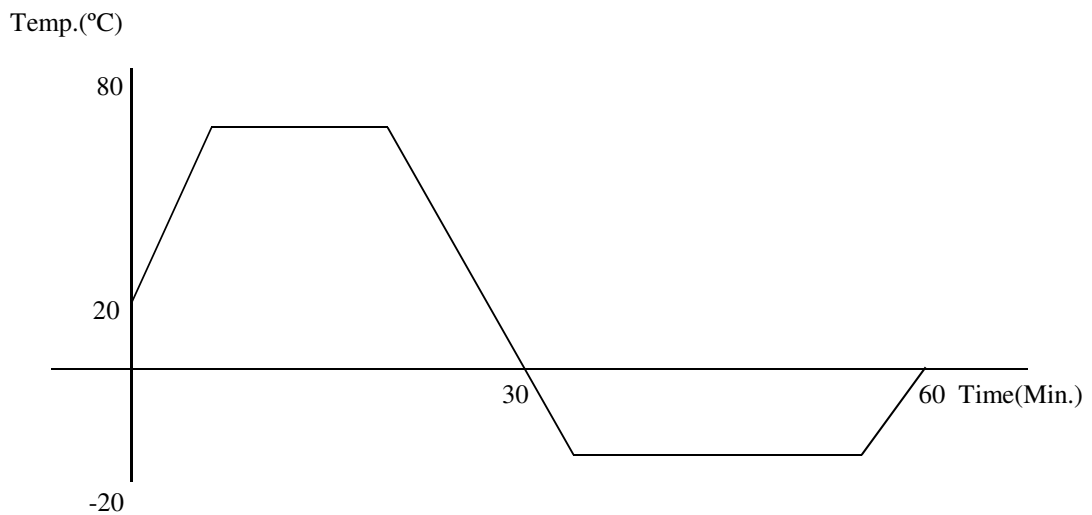

**11. Notation of lot number**

Marking position : Bottom of PWB

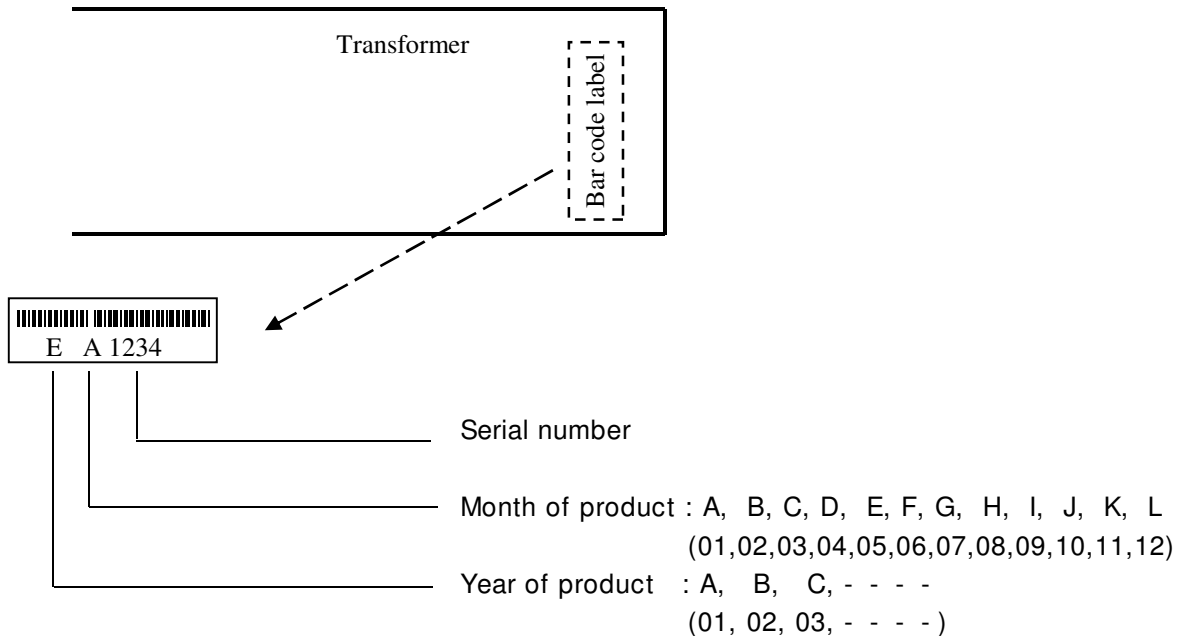

**12. Packing**

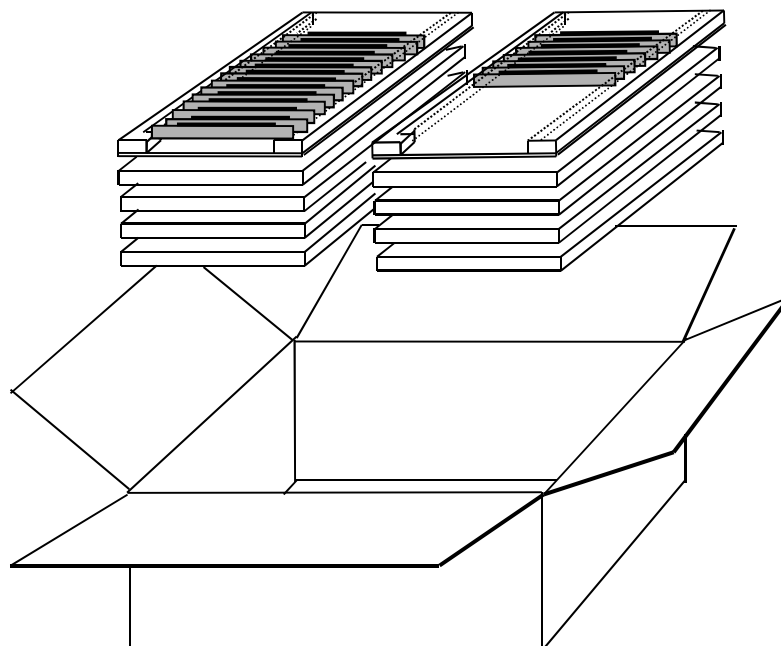







15. PCB Lay- Out



< Bottom Side >

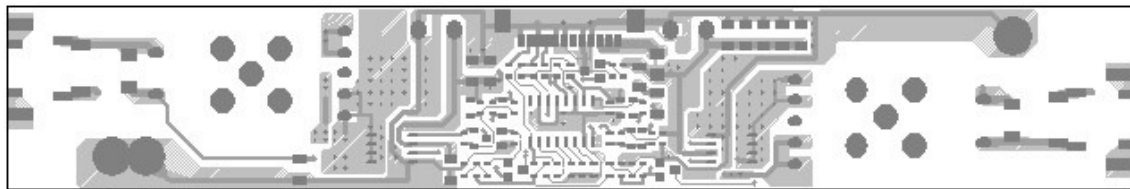

< Top Side >



< Components Lay-Out >

**16. Material List**

Symbol	Component	Type No.	Manufacture	Description
F1	FUSE	3216TD2-R	Cooper bussmann or Equivalent	UL File No.-E19180
	PCB		ERE Electronics or Equivalent	UL File No.-E213562
CN1	Connector	12505WR-12A00	YEONHO or Equivalent	UL File No.-E108706
CN2,3	Connector	35001WR-02A00	YEONHO or Equivalent	UL File No.-E108706
△ T1,2	Transformer	DS-2823	Dongheung or Equivalent	See Specification