

DS26LS32AC/DS26LS32C/DS26LS32M/DS26LS33M Quad Differential Line Receivers

General Description

The DS26LS32 and DS26LS32A are quad differential line receivers designed to meet the RS-422, RS-423 and Federal Standards 1020 and 1030 for balanced and unbalanced digital data transmission.

The DS26LS32 and DS26LS32A have an input sensitivity of 200 mV over the input voltage range of $\pm 7V$ and the DS26LS33 have an input sensitivity of 500 mV over the input voltage range of $\pm 15V$.

The DS26LS32A differ in function from the popular DS26LS32 and DS26LS33 in that input pull-up and pull-down resistors are included which prevent output oscillation on unused channels.

Each version provides an enable and disable function common to all four receivers and features TRI-STATE[®] outputs with 8 mA sink capability. Constructed using low power Schottky processing, these devices are available over the full military and commercial operating temperature ranges.

Features

- High differential or common-mode input voltage ranges of $\pm 7V$ on the DS26LS32 and DS26LS32A and $\pm 15V$ on the DS26LS33
- $\pm 0.2V$ sensitivity over the input voltage range on the DS26LS32 and DS26LS32A, $\pm 0.5V$ sensitivity on the DS26LS33
- DS26LS32 and DS26LS32A meet all requirements of RS-422 and RS-423
- 6k minimum input impedance
- 100 mV input hysteresis on the DS26LS32 and DS26LS32A, 200 mV on the DS26LS33
- Operation from a single 5V supply
- TRI-STATE outputs, with choice of complementary output enables for receiving directly onto a data bus

Logic Diagram

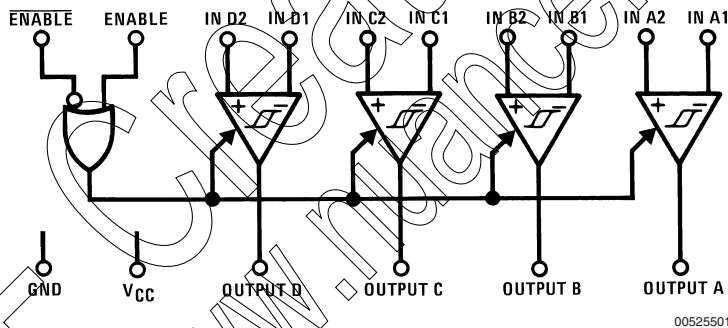

TRI-STATE[®] is a registered trademark of National Semiconductor Corporation.

Connection Diagrams

Dual-In-Line Package

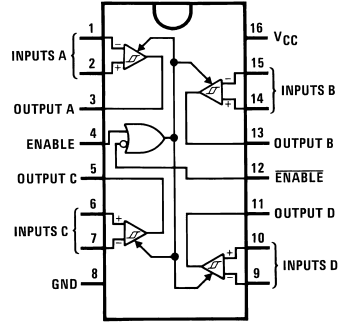

00525502

20-Lead Ceramic Leadless Chip Carrier

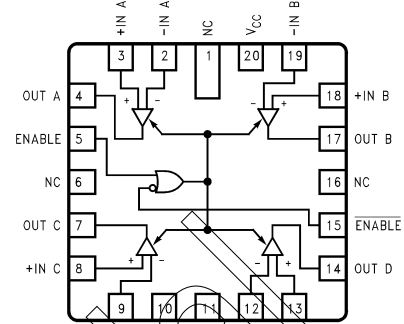

00525512

Top View

Order Number DS26LS32CM, DS26LS32CN,
DS26LS32ACM, DS26LS32ACN, DS26LS33ACM
or DS26LS33ACN

See NS Package Number M16A or N16E
For Complete Military Product Specifications,
refer to the appropriate SMD or MDS.

Order Number DS26LS32MJ/883, DS26LS32MW/883,
DS26LS32ME/883, DS26LS33MW/883

See NS Package Number E20A, J16A or W16A

Truth Table

ENABLE	$\overline{\text{ENABLE}}$	Input	Output
0	1	X	Hi-Z
See Note Below		$V_{ID} \geq V_{TH} \text{ (Max)}$	1
		$V_{ID} \leq V_{TH} \text{ (Min)}$	0

Hi-Z = TRI-STATE®

Note: Input conditions may be any combination not defined for ENABLE and $\overline{\text{ENABLE}}$.

Absolute Maximum Ratings (Note 3)

If Military/Aerospace specified devices are required, please contact the National Semiconductor Sales Office/Distributors for availability and specifications.

Supply Voltage	7V
Common-Mode Range	±25V
Differential Input Voltage	±25V
Enable Voltage	7V
Output Sink Current	50 mA
Maximum Power Dissipation (Note 1) at 25°C	
Cavity Package	1433 mW
Molded Dip Package	1362 mW
SO Package DS26LS32	1002 mW
DS26LS32A	1051 mW
Storage Temperature Range	-65°C to +165°C
Lead Temperature (Soldering, 4 seconds)	260°C

Operating Conditions

	Min	Max	Units
Supply Voltage, (V _{CC})			
DS26LS32M, DS26LS33M (MIL)	4.5	5.5	V
DS26LS32C, DS26LS32AC (COML)	4.75	5.25	V
Temperature, (T _A)			
DS26LS32M, DS26LS33M (MIL)	-55	+125	°C
DS26LS32C, DS26LS32AC (COML)	0	+70	°C

Note 1: Derate cavity package 9.6 mW/°C above 25°C; derate molded DIP package 10.9 mW/°C above 25°C.

Note 2: Derate SO Package 8.01 mW/°C for DS26LS32, 8.41 mW/°C for DS26LS32A

Electrical Characteristics (Notes 4, 5, 6)

over the operating temperature range unless otherwise specified

Symbol	Parameter	Conditions	Min	Typ	Max	Units
V _{TH}	Differential Input Voltage	V _{OUT} = V _{OH} or V _{OL} DS26LS32, DS26LS32A, -7V ≤ V _{CM} ≤ +7V DS26LS33, DS26LS33A, -15V ≤ V _{CM} ≤ +15V	-0.2 -0.5	±0.07 ±0.14	0.2 0.5	V
R _{IN}	Input Resistance	-15V ≤ V _{CM} ≤ +15V (One Input AC GND)	6.0	8.5		kΩ
I _{IN}	Input Current (Under Test)	V _{IN} = 15V, Other Input -15V ≤ V _{IN} ≤ +15V V _{IN} = -15V, Other Input -15V ≤ V _{IN} ≤ +15V			2.3 -2.8	mA
V _{OH}	Output High Voltage	V _{CC} = MIN, ΔV _{IN} = 1V, V _{ENABLE} = 0.8V, I _{OH} = -440 μA	Commercial 2.7 Military 2.5	4.2 4.2		V
V _{OL}	Output Low Voltage	V _{CC} = Min, ΔV _{IN} = -1V, V _{ENABLE} = 0.8V	I _{OL} = 4 mA I _{OL} = 8 mA		0.4 0.45	V
V _{IL}	Enable Low Voltage				0.8	V
V _{IH}	Enable High Voltage		2.0			V
V _I	Enable Clamp Voltage	V _{CC} = Min, I _{IN} = -18 mA			-1.5	V
I _O	OFF-State (High Impedance) Output Current	V _{CC} = Max	V _O = 2.4V V _O = 0.4V		20 -20	μA
I _{IL}	Enable Low Current	V _{IN} = 0.4V			-0.36	mA
I _{IH}	Enable High Current	V _{IN} = 2.7V			20	μA
I _{SC}	Output Short-Circuit Current	V _O = 0V, V _{CC} = Max, ΔV _{IN} = 1V	-15		-85	mA
I _{CC}	Power Supply Current	V _{CC} = Max, All V _{IN} = GND, Outputs Disabled	DS26LS32, DS26LS32A DS26LS33, DS26LS33A	52 57	70 80	mA
I _I	Input High Current	V _{IN} = 5.5V			100	μA
V _{HYST}	Input Hysteresis	T _A = 25°C, V _{CC} = 5V, V _{CM} = 0V	DS26LS32, DS26LS32A DS26LS33, DS26LS33A	100 200		mV

Note 3: "Absolute Maximum Ratings" are those values beyond which the safety of the device cannot be guaranteed. They are not meant to imply that the device should be operated at these limits. The table of "Electrical Characteristics" provides conditions for actual device operation.

Note 4: All currents into device pins are shown as positive, all currents out of device pins are shown as negative, all voltages are referenced to ground, unless otherwise specified. All values shown as max or min are so classified on absolute value basis.

Note 5: All typical values are V_{CC} = 5 V, T_A = 25°C.

Note 6: Only one output at a time should be shorted.

Switching Characteristics

$V_{CC} = 5V, T_A = 25^\circ C$

Symbol	Parameter	Conditions	DS26LS32/DS26LS33			DS26LS32A/DS26LS33A			Units
			Min	Typ	Max	Min	Typ	Max	
t_{PLH}	Input to Output	$C_L = 1\ 5p\ F$		17	25		23	35	ns
t_{PHL}				17	25		23	35	ns
t_{LZ}	ENABLE to Output	$C_L = 5\ pF$		203	0		153	0	ns
t_{HZ}				15	22		20	25	ns
t_{ZL}	ENABLE to Output	$C_L = 1\ 5p\ F$		15	22		14	22	ns
t_{ZH}				15	22		15	22	ns

AC Test Circuit and Switching Time Waveforms

Load Test Circuit for TRI-STATE® Outputs

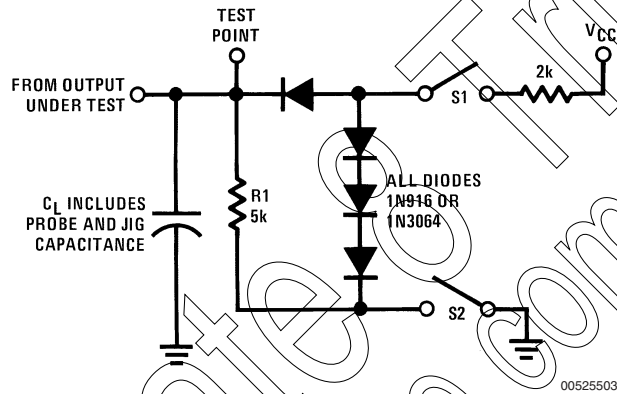

Propagation Delay (Notes 7, 9)

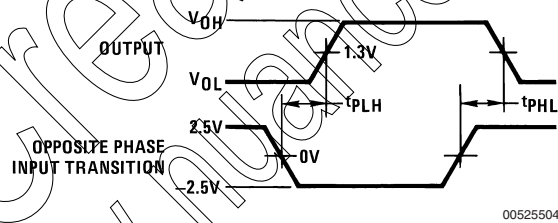

Enable and Disable Times (Notes 8, 9)

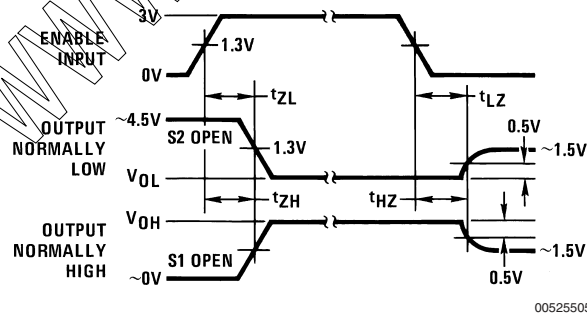

Note 7: Diagram shown for \overline{ENABLE} low.

Note 8: S1 and S2 of load circuit are closed except where shown.

Note 9: Pulse generator for all pulses: Rate = 1.0 MHz; $Z_O = 50\Omega$; $t_r \leq 6\ ns$; $t_f \leq 6.0\ ns$.

Typical Applications

Two-Wire Balanced Interface—RS-422

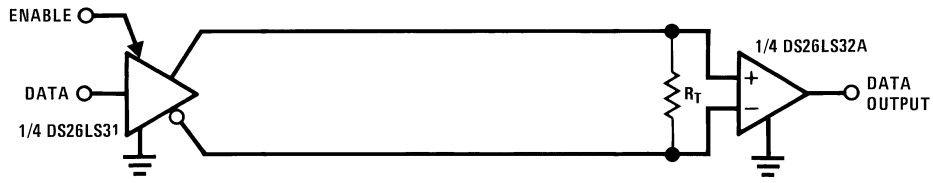

Single Wire with Driver Ground Reference—RS-423

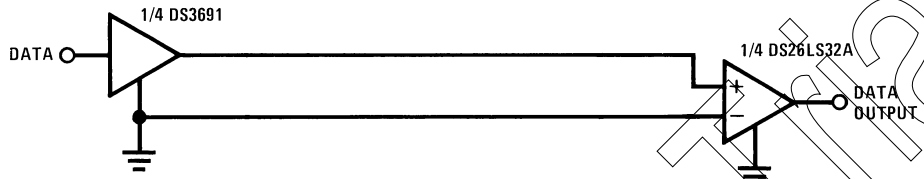

PDF Create 8
www.nuance.com

Physical Dimensions inches (millimeters)

unless otherwise noted

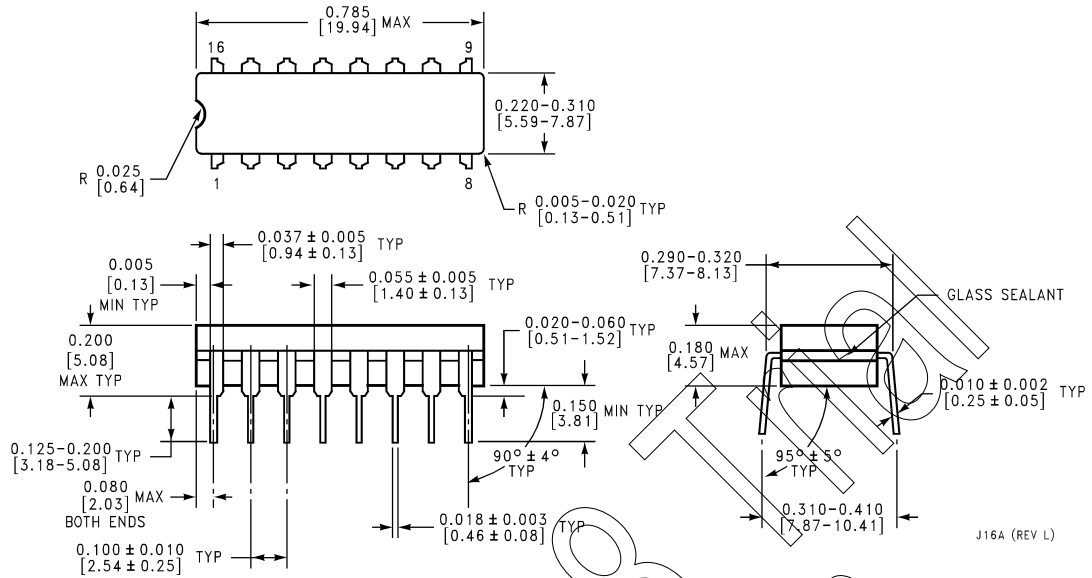

Ceramic Dual-In-Line Package (J)
Order Number DS26LS32MJ/883 or DS26LS33MJ/883
NS Package Number J16A

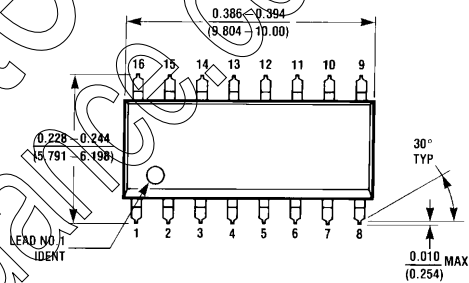

Small Outline Package (M)
Order Number DS26LS32CM or DS26LS32ACM
NS Package Number M16A

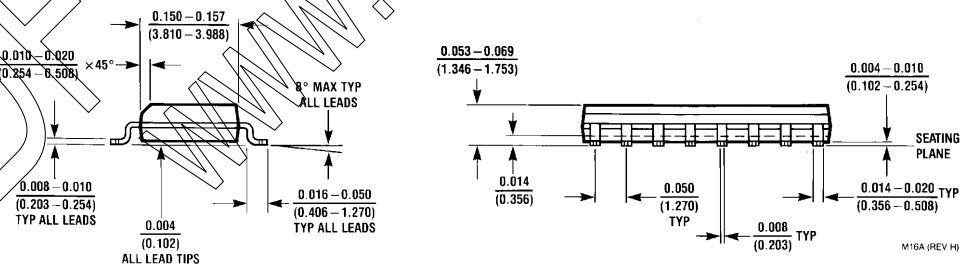

Physical Dimensions inches (millimeters) unless otherwise noted (Continued)

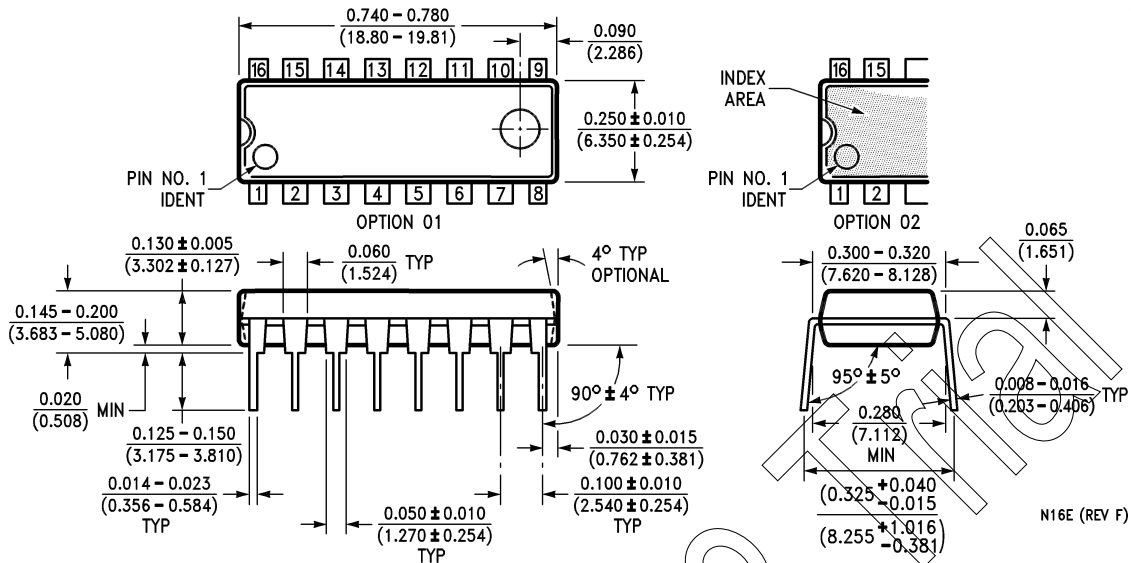

Molded Dual-In-Line Package (N)
 Order Number DS26LS32CN or DS26LS32ACN
 NS Package Number N16E

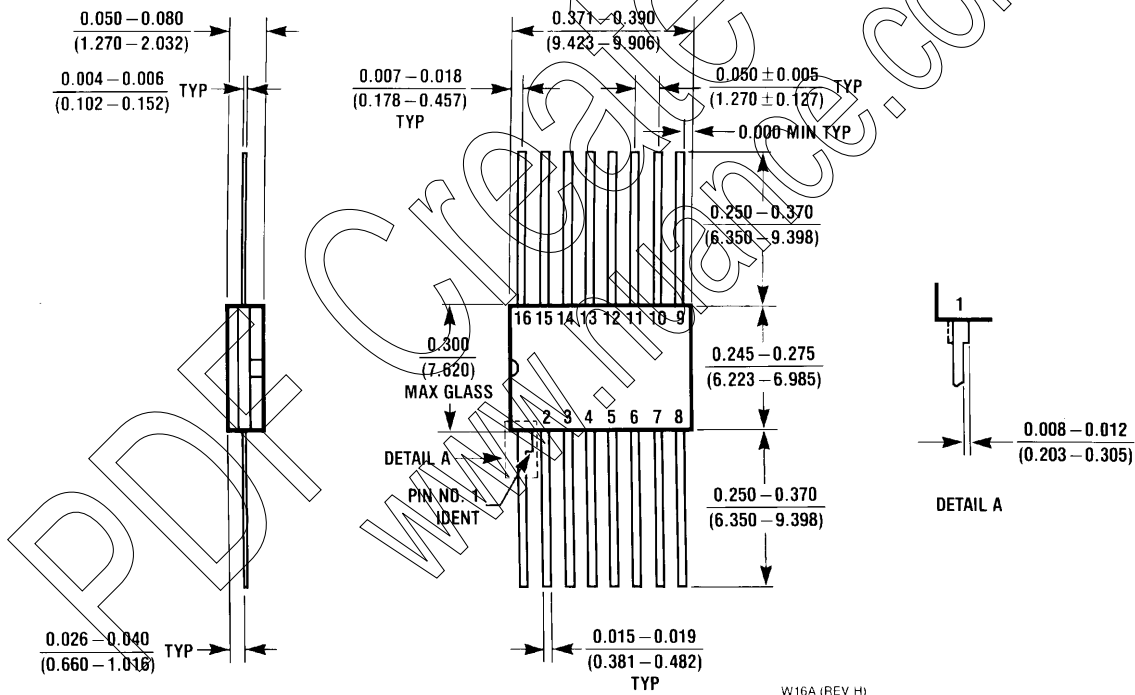

16 Lead Ceramic Flatpak (W)
 Order Number DS26LS32MW/883 or DS26LS33MW/883
 NS Package Number W16A

Physical Dimensions inches (millimeters) unless otherwise noted (Continued)

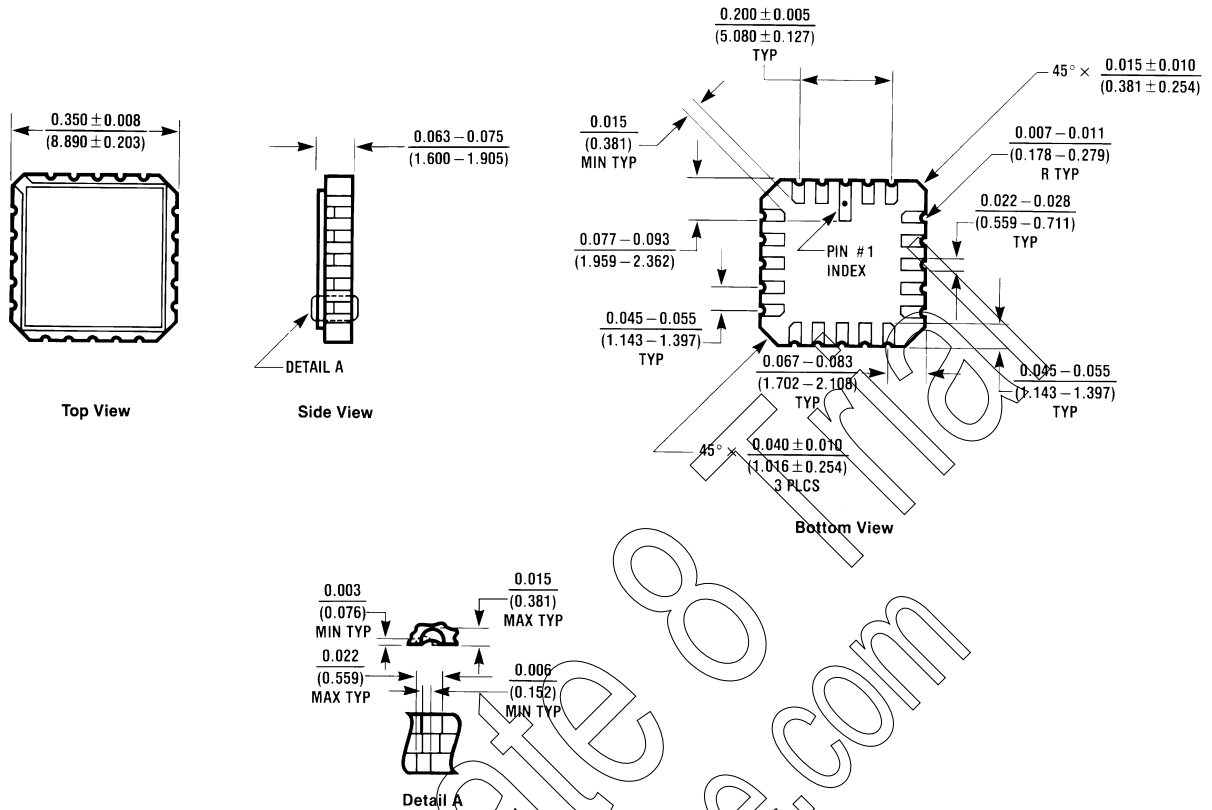

20 Lead Ceramic Leadless Chip Carrier (E)
Order Number DS26LS32ME/883
NS Package Number E20A

E20A (REV D)

LIFE SUPPORT POLICY

NATIONAL'S PRODUCTS ARE NOT AUTHORIZED FOR USE AS CRITICAL COMPONENTS IN LIFE SUPPORT DEVICES OR SYSTEMS WITHOUT THE EXPRESS WRITTEN APPROVAL OF THE PRESIDENT AND GENERAL COUNSEL OF NATIONAL SEMICONDUCTOR CORPORATION. As used herein:

1. Life support devices or systems are devices or systems which, (a) are intended for surgical implant into the body, or (b) support or sustain life, and whose failure to perform when properly used in accordance with instructions for use provided in the labeling, can be reasonably expected to result in a significant injury to the user.
2. A critical component is any component of a life support device or system whose failure to perform can be reasonably expected to cause the failure of the life support device or system, or to affect its safety or effectiveness.

BANNED SUBSTANCE COMPLIANCE

National Semiconductor certifies that the products and packing materials meet the provisions of the Customer Products Stewardship Specification (CSP-9-111C2) and the Banned Substances and Materials of Interest Specification (CSP-9-111S2) and contain no "Banned Substances" as defined in CSP-9-111S2.



National Semiconductor
Americas Customer Support Center
 Email: new.feedback@nsc.com
 Tel: 1-800-272-9959

National Semiconductor
Europe Customer Support Center
 Fax: +49 (0) 180-530 85 86
 Email: europe.support@nsc.com
 Deutsch Tel: +49 (0) 69 9508 6208
 English Tel: +44 (0) 870 24 0 2171
 Français Tel: +33 (0) 1 41 91 8790

National Semiconductor
Asia Pacific Customer Support Center
 Email: ap.support@nsc.com

National Semiconductor
Japan Customer Support Center
 Fax: 81-3-5639-7507
 Email: jpn.feedback@nsc.com
 Tel: 81-3-5639-7560

www.national.com