

FILE NO.

SERVICE MANUAL

Remote Control Color Television

DS27820 (U.S.A.)
ORIGINAL VERSION

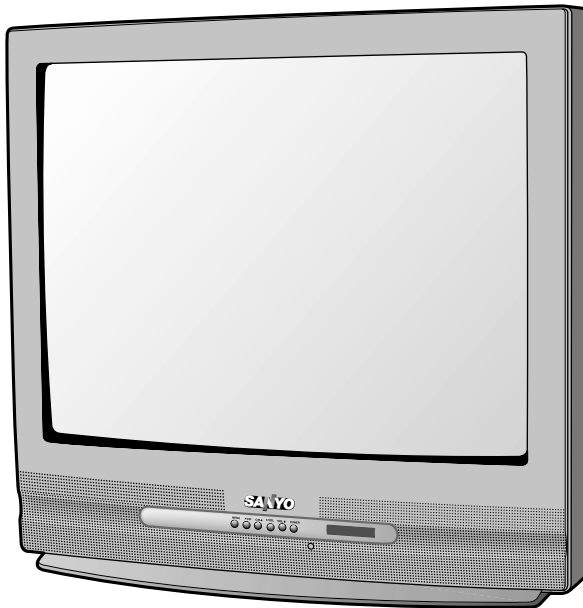

Chassis No. 27820-00

NOTE: Match the Chassis No. on the unit's back cover with the Chassis No. in the Service Manual.

If the Original Version Service Manual Chassis No. does not match the unit's, additional Service Literature is required. You must refer to "Notices" to the Original Service Manual prior to servicing the unit.

Contents

Safety Instructions	2
Service Adjustments	3 - 9
Service Hints	10
Mechanical Disassemblies	11
Chassis Electrical Parts List	12 - 22
Cabinet Parts List	23
Component and Test Point	
Locations	24 - 27
Schematic Insert	29 - 36
Schematic Notes	29
Pin Layouts	29
Capacitor and Resistor Codes	29
Block Diagram	30 - 31
Voltage Charts	30 - 32
Waveforms	32
Schematic Diagram	33 - 36

Specifications

Power Rating	120V, 60Hz 86W (Avg), 2.5A (Max)
Antenna Input Impedance	75Ω UHF/VHF/CATV
Receiving Channel	2 - 13 (VHF), 14 - 69 (UHF), 01, 14-94, 95-125 (CATV)
Remote Ready	38 Key Remote Control
Sound Output	3.0 W/CH
Intermediate Frequency	
Picture IF Carrier	45.75MHz
Sound IF Carrier	41.25MHz
Color Sub Carrier	42.17MHz
Picture Tube	A68AJB82X04
Semiconductors	
Integrated Circuits	12
Transistors	32
	Except within Tuner and RC Pre-Amp.
Cabinet Dimensions	
Width	664 mm
Height	629 mm
Depth	541 mm

SAFETY INSTRUCTIONS

SAFETY PRECAUTIONS

WARNING: The chassis of this receiver has a floating ground with the potential of one half the AC line voltage in respect to earth ground. Service should not be attempted by anyone not familiar with the precautions necessary when working on this type of equipment.

The following precautions must be observed:

1. An isolation transformer must be connected in the power line between the receiver and the AC line before any service is performed on the receiver.
2. Comply with all caution and safety-related notes provided on the side of the cabinet, inside the cabinet, on the chassis, and the picture tube.
3. When replacing a chassis in the cabinet, always be certain that all the protective devices are installed properly, such as control knobs, adjustment covers, shields and barriers.

DO NOT OPERATE THIS TELEVISION RECEIVER WITHOUT THE PROTECTIVE SHIELD IN POSITION AND PROPERLY SECURED.

4. Before replacing the back cover of the set, thoroughly inspect the inside of the cabinet to see that no stray parts or tools have been left inside.
Before returning any television to the customer, the service technician must perform the following safety checks to be sure that the unit is completely safe to operate without danger of electrical shock.

ANTENNA COLD CHECK

Remove AC plug from the 120 VAC outlet and place a jumper across the two blades. Connect one lead of an ohmmeter to the jumpered AC plug, and touch the other lead to each exposed antenna terminal (UHF and VHF antenna terminals). The resistance must measure between 1M ohm and 5.2M ohm. Any resistance value below or above this range indicates an abnormality which requires corrective action.

LEAKAGE CURRENT CHECK

Plug the AC line cord directly into a 120 VAC outlet. (Do not use an isolation transformer for this check.) Use an AC voltmeter, that has 5000 ohms per volt or more sensitivity. Connect a 1500 ohm 10 watt resistor, paralleled by a 0.15 μ F 150 VAC capacitor, between a known good earth ground (water pipe, conduit, etc.) and all exposed metal parts of the cabinet (antennas, handle bracket, metal cabinet, screw heads, metal overlays, control shafts, etc.). Measure the AC voltage across the 1500 ohm resistor. The AC voltage should not exceed 750 mV. A reading exceeding 750 mV indicates that a dangerous potential exists. The fault must be located and corrected. Repeat the above test with the receiver power plug reversed.

NEVER RETURN A RECEIVER TO THE CUSTOMER WITHOUT TAKING THE NECESSARY CORRECTIVE ACTION.

READING SHOULD NOT EXCEED 750 mV.
AC VOLTMETER
(5000 ohms per volt or more sensitivity)

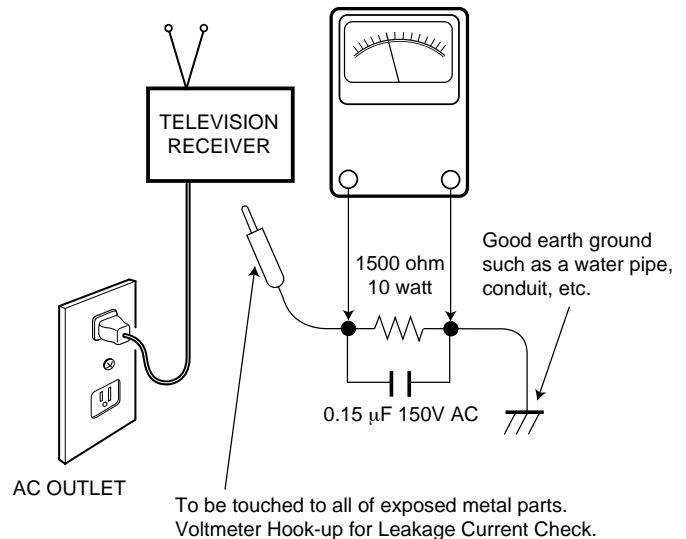

X-RADIATION PRECAUTION

The primary source of X-RADIATION in solid-state receivers is the picture tube. The picture tube is specially constructed to limit X-Ray emission. For continued X-RADIATION protection, the replacement tube must be the same type as the original (including the suffix letter in the part numbers). Excessive high voltage may produce potentially hazardous X-RADIATION. To avoid such hazards, the high voltage must be maintained within specific limits. Refer to the X-RADIATION WARNING NOTE on the CHASSIS SCHEMATIC in this service manual for specific high voltage limits. If the high voltage exceeds specified limits, check the components specified on the chassis schematic diagram and take the necessary corrective action. Carefully follow the instructions for the +B Voltage Check and the High Voltage Check to maintain the high voltage within the specified limits.

HIGH VOLTAGE HOLD-DOWN TEST

To prevent X-RADIATION from the picture tube due to excessive high voltage, a HOLD-DOWN circuit is provided in the high voltage circuit. Every time the receiver is serviced, the high voltage HOLD-DOWN circuit must be tested for proper operation. Refer to the HIGH VOLTAGE HOLD-DOWN TEST in service adjustments.

PRODUCT SAFETY NOTICE

When replacing components in a receiver, always keep in mind the necessary product safety precautions. Pay special attention to the replacement of components marked with a star (★) in the parts list and in the schematic diagrams. To ensure safe product operation, it is necessary to replace those components with the exact same PARTS.

SERVICE ADJUSTMENTS

GENERAL

This set has an On-screen Service Menu system included in the CPU that allows remote operation for most of the service adjustments.

IC802 (EEPROM) REPLACEMENT

When IC802 (EEPROM) is replaced, IC801 (CPU) will automatically write the initial reference data into IC802 for basic TV operation. However, the bus data should be checked and some bus data should be set up before attempting the service adjustments. (See pages 4 – 6 for detailed information.)

INITIAL BUS DATA SETUP

Note: When IC802 (EEPROM) is replaced, the Service Menu NO. 03 HP (H Phase), NO. 05 VPO (V Position), NO. 07 VLN (V Lin), NO. 10 VSC (V S Correction), NO. 14 VC (V Compression), NO. 21 SBI (Sub Bias), NO. 28 PRE (Preshoot Adj), NO. 29 WP (White Peak Limiter), NO. 32 BSG (Black Str Gain), NO. 34 DCR (DC Reset), NO. 37 AF (Auto Flesh), NO. 41 RYA (R-Y/B-Y Angle), NO. 54 SCO (Sub Color), NO. 56 SSH (Sub Sharpness), NO. 57 OPT (SA Option), NO. 58 OP2 (SA Option 2), and NO. 59 HR (OSD Position) should be set up for proper TV operation before attempting the service adjustments.

1. Disconnect the AC power cord (AC 120V line).
2. While pressing the MENU key, reconnect the AC power cord. The Service Menu display will now appear.
3. Select NO. 03 HP (H Phase) with ▲ or ▼ key. Adjust the data with + or – key for 10.
4. Select NO. 05 VPO (V Position) with ▲ or ▼ key. Adjust the data with + or – key for 12.
5. Select NO. 07 VLN (V Lin) with ▲ or ▼ key. Adjust the data with + or – key for 13.
6. Select NO. 10 VSC (V S Correction) with ▲ or ▼ key. Adjust the data with + or – key for 15.
7. Select NO. 14 VC (V Compression) with ▲ or ▼ key. Adjust the data with + or – key for 7.
8. Select NO. 21 SBI (Sub Bias) with ▲ or ▼ key. Adjust the data with + or – key for 54.
9. Select NO. 28 PRE (Preshoot Adj) with ▲ or ▼ key. Adjust the data with + or – key for 2.
10. Select NO. 29 WP (White Peak Limiter) with ▲ or ▼ key. Adjust the data with + or – key for 1.
11. Select NO. 32 BSG (Black Str Gain) with ▲ or ▼ key. Adjust the data with + or – key for 2.
12. Select NO. 34 DCR (DC Reset) with ▲ or ▼ key. Adjust the data with + or – key for 1.
13. Select NO. 37 AF (Auto Flesh) with ▲ or ▼ key. Adjust the data with + or – key for 1.
14. Select NO. 41 RYA (R-Y/B-Y Angle) with ▲ or ▼ key. Adjust the data with + or – key for 2.
15. Select NO. 54 SCO (Sub Color) with ▲ or ▼ key. Adjust data with + or – key for 5.
16. Select NO. 56 SSH (Sub Sharpness) with ▲ or ▼ key. Adjust data with + or – key for 8.
17. Select NO. 57 OPT (SA Option) with ▲ or ▼ key. Adjust the data with + or – key for 88.
18. Select NO. 58 OP2 (SA Option 2) with ▲ or ▼ key. Adjust the data with + or – key for 54.
19. Select NO. 59 HR (OSD Position) with ▲ or ▼ key. Adjust the data with + or – key for 18.
20. Press the MENU key to turn off the Service Menu display.

ON-SCREEN SERVICE MENU SYSTEM

1. Enter the Service Menu:

- While pressing the MENU key, reconnect the AC power cord. The Service Menu Display will now appear. (See Figure 1.)

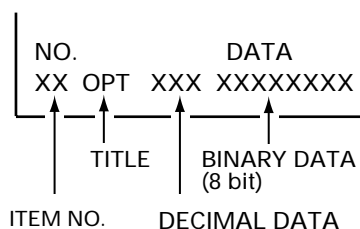

Figure 1. Service Menu Display

2. Service Adjustments:

- Press the ▲ or ▼ key to select the desired service menu you want to adjust. (See page 4 for On-screen Service Menu.)
- Use the + or – key to adjust the data.

3. Exit from the Service Menu:

- Press the MENU key to turn off the Service Menu display.

Table 1. ON-SCREEN SERVICE MENU

When IC802 (EEPROM) is replaced, check the bus data to confirm they are the same as below. The shaded menu should be checked and be set up or readjusted according to the procedures described in the following pages. Initial Setup Data marked with an * should be changed from Initial Reference Data. (See page 3 for Initial Bus Data Setup.)

NO.	TITLE	INITIAL REFERENCE DATA	INITIAL SETUP DATA	RANGE OF DATA	FUNCTION
01	HFR	29	29	0~63	Horizontal Frequency
02	AFC	0	0	0, 1	AFC Gain & Gate
03	HP	11	10*	0~31	Horizontal Phase (Horizontal Centering)
04	VS	64	64	0~127	Vertical Size
05	VPO	32	12*	0~63	Vertical Position
06	VSP	0	0	0, 1	Vertical Set Up (Sync Sensitivity)
07	VLN	17	13*	0~31	Vertical Linearity
08	CRS	0	0	0~3	Cross B/W
09	GRY	1	1	0, 1	Gray Mode
10	VSC	10	15*	0~31	Vertical S Correction
11	HBR	3	3	0~7	H BLK R
12	HBL	4	4	0~7	H BLK L
13	CDM	0	0	0, 1	C D Mode
14	VC	5	7*	0~7	Vertical Compression
15	RB	0	0	0~255	Red Bias
16	GB	0	0	0~255	Green Bias
17	BB	0	0	0~255	Blue Bias
18	RD	64	64	0~127	Red Drive
19	GD	8	8	0~15	Green Drive
20	BD	64	64	0~127	Blue Drive
21	SBI	64	54*	0~127	Sub Bias
22	OSD	2	2	0~3	OSD Contrast
23	POS	0	0	0, 1	Pre/Over SW
24	FLS	2	2	0~7	Filter System
25	CKO	3	3	0~7	Color Killer Operation
26	GYA	0	0	0, 1	G-Y Angle
27	CRG	2	2	0~3	Coring Gain
28	PRE	1	2*	0~3	Pre Shoot Adjust
29	WP	0	1*	0, 1	White Peak Limiter
30	FSW	0	0	0, 1	FBP Blanking Switch
31	VBL	0	0	0, 1	Vertical Blanking Switch
32	BSG	1	2*	0~3	Black Str Gain
33	BSS	1	1	0~3	Black Str Start
34	DCR	0	1*	0~3	DC Reset
35	YGM	1	1	0~3	Y Gamma
36	CBP	0	0	0, 1	C Bypass
37	AF	0	1*	0, 1	Auto Flesh
38	BAT	4	4	0~7	Bright ABL Threshold
39	MSD	0	0	0, 1	Mid Stop Def
40	ABL	0	0	0, 1	Auto Bright Limit
41	RYA	4	2*	0~15	R-Y/B-Y Angle
42	RAD	20	20	0~63	RF AGC Delay
43	IAS	0	0	0, 1	IF AGC
44	FMM	0	0	0, 1	FM Mute
45	FL	15	15	0~31	FM Level

Table 1. ON-SCREEN SERVICE MENU (Continued)

When IC802 (EEPROM) is replaced, check the bus data to confirm they are the same as below. The shaded menu should be checked and be set up or readjusted according to the procedures described in the following pages. Initial Setup Data marked with an * should be changed from Initial Reference Data. (See page 3 for Initial Bus Data Setup.)

NO.	TITLE	INITIAL REFERENCE DATA	INITIAL SETUP DATA	RANGE OF DATA	FUNCTION
46	VL	4	4	0~7	Video Level
47	EWD	39	39	0~63	EW DC
48	EWA	30	30	0~63	EW Amp
49	EWT	34	34	0~63	EW Tilt
50	EWP	7	7	0~7	EW Corner Top
51	EWB	8	8		EW Corner Bottom
52	HSC	4	4		Horz Size Comp
53	SB	32	32	0~63	Sub Bright
54	SCO	7	5*	0~31	Sub Color
55	STI	20	20	0~31	Sub Tint
56	SSH	12	8*	0~31	Sub Sharpness
57	OPT	0	88*	0~255	Option (See Note 1 page 6.)
58	OP2	0	54*	0~255	Option 2 (See Note 2 page 6.)
59	HR	24	18*	0~63	OSD Horizontal Position
60	ATT	10	10	0~63	Input Level
61	WDB	32	32	0~63	Wideband
62	SPC	32	32	0~63	Spectral
63	SBO	5	5	0~255	Sub Bright Offset
64	PCO	40	40	0~63	PIP Color
65	PTI	40	40	0~63	PIP Tint
66	PUV	24	24	0~63	PIP Top Position
67	PDV	147	147	0~255	PIP Bottom Position
68	PLH	10	10	0~63	PIP Left Position
69	PRH	101	101	0~255	PIP Right Position
70	PCN	42	42	0~63	PIP Y Level
71	PBS	15	15	0~63	PIP BGP Phase
72	DRV	64	64	0~127	Red Drive Adjustment (See Note 3 page 6.)
		64	64	0~127	Blue Drive Adjustment (See Note 3 page 6.)
73	-	0	0	0~255	Red Bias Adjustment (See Note 4 page 6.)
	-	0	0	0~255	Green Bias Adjustment (See Note 4 page 6.)
	-	0	0	0~255	Blue Bias Adjustment (See Note 4 page 6.)

SERVICE ADJUSTMENTS (Continued)

PROGRAM CODES

The microprocessor used in this model is a multi-purpose type and is used in several different models. To ensure proper operation and the correct features for your particular model, the Program Codes must be correct.

Note 1. Option Data 1 (NO. 57 OPT) should be decimal 88 (01011000 binary). See page 3 INITIAL DATA SETUP, step 17, for set up procedure. If this program code is wrong the TV will not operate properly.

BIT	FUNCTION	DATA	
		01	
0 ~ 2	NOT USED	—	—
3	CLOCK	NONE	YES
4	COMB FILTER	NONE	YES
5	NOT USED	—	—
6, 7	SURROUND	00: NONE 01: YES 10: — 11: —	

Note 2. Option Data 2 (NO. 58 OP2) should be decimal 54 (00110110 binary). See page 3 INITIAL DATA SETUP, step 18, for set up procedure. If this program code is wrong the TV will not operate properly.

BIT	FUNCTION	DATA	
		0	1
0	SHIPPING CONDITION OF COLOR ENHANCER	NORMAL	COOL
1	COLOR ENHANCER	NONE	YES
2	INITIAL CH & XDS	NONE	YES
3	AUDIO OUT & SP MENU	NONE	YES
4	PIP	NONE	YES
5	AV INPUTS	1 SET	2 SETS
6	BASS & TREBLE / TONE	BASS & TR	TONE
7	NOT USED	—	—

DRIVE / BIAS ADJUSTMENTS

Note 3. Red/Blue Drive Adjustments in Service Menu NO. 72 DRV: Adjust Red and Blue Drive Levels alternately with 1, 3, 7, and 9 keys on the remote control. (See Figure 2.) The Drive Level adjustment data will be written in the Service Menu No. 18 and 20 automatically.

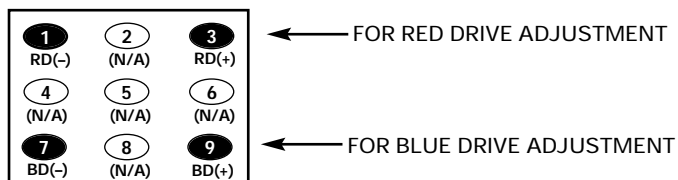

Figure 2.

Note 4. Red/Green/Blue Bias Adjustments in Service Menu NO. 73: Adjust each Bias Level with 1, 3, 4, 6, 7, or 9 key on the remote control. (See Figure 3.) The Bias Level adjustment data will be written in the Service Menu No. 15 ~ 17 automatically.

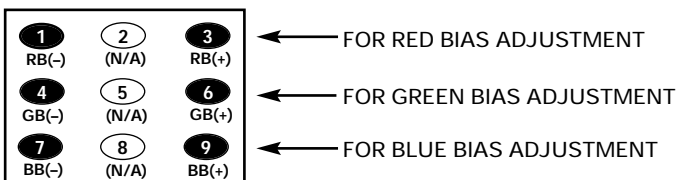

Figure 3.

ANTENNA CONNECTIONS

This receiver is designed for UHF/VHF reception. A 75 ohm terminal is provided for UHF and VHF receptions. When connecting a CATV antenna system, connect the 75 ohm coaxial cable directly to the 75 ohm terminal. For 300 ohm VHF antenna, use an adapter (not included with the TV set).

CIRCUIT PROTECTION

Fuse F601 (4A) is included in the AC line. This fuse must be replaced with the proper fuse (see Parts List).

CAUTION

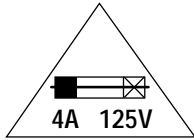

FOR CONTINUED PROTECTION AGAINST A RISK OF FIRE, REPLACE ONLY WITH THE SAME TYPE 4A, 125V FUSE.

ATTENTION : POUR MAINTENIR LA PROTECTION CONTRE LES RISQUES D' INCENDIE UTILISER UN FUSIBLE DE RECHANGE DE MEME TYPE 4A, 125V.

+B VOLTAGE CHECK

Connect Voltmeter + lead to TJ1 130V and – lead to ground (TE7). Connect receiver to AC 120V line. Tune receiver to an active channel. Reset the picture controls to the FACTORY PRESET levels (press remote control RESET key twice). Voltage must measure between +128.0V and +132.0V. If the voltage is out of this range, the power circuit must be checked. No +B adjustment is provided on this chassis.

HORIZONTAL CENTERING ADJUSTMENT

1. Tune receiver to an active channel.
2. Check that picture is in the horizontal center of TV screen. If picture is not centered horizontally, perform steps 3 - 6.
3. Turn off the receiver and disconnect the AC power cord.
4. While pressing the MENU key, reconnect the AC power cord. The Service Menu display will now appear.
5. Select NO. 03 HP (Horizontal Phase) with ▲ or ▼ key.
6. Adjust the data with + or – key for horizontal center. To turn off the Service Menu display, press the MENU key.

VERTICAL SIZE ADJUSTMENT

1. Tune receiver to an active channel.
2. Check the vertical size of the picture. If the vertical size is too large or small, perform steps 3 - 6.
3. Turn off the receiver and disconnect the AC power cord.
4. While pressing the MENU key, reconnect the AC power cord. The Service Menu display will now appear.
5. Select NO. 04 VS (Vertical Size) with ▲ or ▼ key.
6. Adjust the data with + or – key for full scan. To turn off the Service Menu display, press the MENU key.

VERTICAL CENTERING ADJUSTMENT

1. Tune receiver to an active channel.
2. Check that picture is in the center of TV screen. If picture center is too low, change resistor R513 from 1K ohm 1/2W to 470 ohm 1W. If picture center is too high, remove resistor R513 (1K ohm, 1/2W).

VCO ADJUSTMENT

Note: VCO must be adjusted after IC101 (Signal Processor), IC802 (EEPROM) or T151 (VCO Coil) is replaced.

1. Tune receiver to an active channel.
2. Set the picture controls to the Sports level.
3. Connect digital voltmeter + lead to pin 58 of IC101 and – lead to ground (TE 7).
4. Confirm a reading of 3.6 ± 0.2 VDC.
5. If voltage is out of specifications adjust T151 for 3.6 ± 0.2 VDC.

RF AGC ADJUSTMENT

1. Tune receiver to strongest VHF station in your area.
2. Set contrast and brightness controls for maximum.
3. Turn off the receiver and disconnect the AC power cord (120V AC line).
4. While pressing the MENU key, reconnect the AC power cord. The Service Menu display will now appear.
5. Select NO. 42 RAD (RF AGC Delay) with ▲ or ▼ key.
6. Adjust the data with + or – key in the direction which causes snow to appear; then in the opposite direction until the snow just disappears.
7. To turn off the Service Menu display, press the MENU key.

VIDEO LEVEL

1. Connect color-bar generator to antenna terminals.
2. Turn off the receiver and disconnect the AC power cord (AC 120V line).
3. Connect oscilloscope to TP16 (Q202 emitter) and ground.
4. While pressing the Menu key, reconnect the AC power cord. The Service Menu will now appear.
5. Select NO. 46 VL (Video Level) with the ▲ or ▼ key.
6. Adjust the + or – key for an oscilloscope reading of 1.0 ± 0.1 VP-P at TP16. Press the MENU key to turn off the Service Menu display.

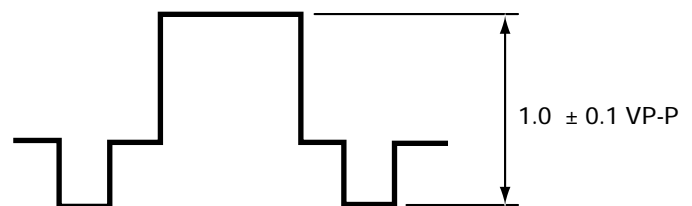

Figure 4.

SERVICE ADJUSTMENTS (Continued)

GRAYSCALE ADJUSTMENT

1. Set the picture controls to the Sports levels or Reset (use MENU key and ▲ or ▼ key or RESET key).
2. Turn off the receiver and disconnect the AC power cord (120V AC line).
3. While pressing the MENU key, reconnect the AC power cord. The Service Menu display will now appear.
4. Select NO. 15 RB (Red Bias), NO. 16 GB (Green Bias), and NO. 17 BB (Blue Bias) with ▲ or ▼ key and set each data to 0 with + or – key.
5. Select NO. 18 RD (Red Drive) and NO. 20 BD (Blue Drive) with ▲ or ▼ key and set each data to 64 with + or – key.
6. Set NO. 19 GD (Green Drive Reduction) data to 8, NO. 53 SB (Sub Brightness) data to 32, NO. 54 SCO (Sub Color) data to 5, NO. 55 STI (Sub Tint) to 20, and NO. 56 SSH (Sub Sharpness) data to 8 with ▲ or ▼, and + or – keys.
7. Turn Screen Control (T402) to minimum (fully counter-clockwise).
8. Select the Service Menu NO. 73 (Bias Adjustments) with ▲ or ▼ key.
9. Advance Screen Control (T402) clockwise to obtain just visible one color line. If line does not appear, place this control to maximum (fully clockwise).
10. Raise each Bias Level with 3, 6, and 9 keys to obtain just visible white line. (See Figure 5.)

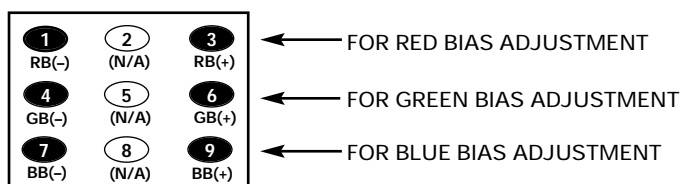

Figure 5. Remote Control Number keys' functions in Service Menu NO. 73

11. Select the Service Menu NO. 72 DRV (Drive Adjustments) with ▲ or ▼ key.
12. Adjust Red and Blue Drive Levels alternately with 1, 3, 7, or 9 key to produce normal black and white picture in highlight areas. (See Figure 6.)



Figure 6. Remote Control Number keys' functions in Service Menu NO. 72 DRV

13. Check for proper grayscale at all brightness levels. To turn off the Service Menu display, press the MENU key.

Note: If Grayscale Adjustment is made after picture tube replacement, check Brightness Level Adjustment.

FOCUS ADJUSTMENT

Adjust focus control (T402) for well defined scanning lines.

BRIGHTNESS LEVEL ADJUSTMENT

Note: Grayscale, RF AGC, Video Level, and High Voltage Check must be adjusted before attempting Brightness Level Adjustment.

1. Connect a color-bar generator to the antenna terminals.
2. Switch the generator to the crosshatch pattern.
3. Reset the picture controls to the Sports levels.
4. Connect voltmeter (high impedance) + lead to terminal TP51 and – lead to terminal TP50 on main board. Set voltmeter for 1.5V ~ 3V range.
5. Turn off the receiver and disconnect the AC power cord.
6. While pressing the MENU key, reconnect the AC power cord. The Service Menu display will now appear.
7. Select NO. 53 SB (Sub Brightness) with ▲ or ▼ key.
8. Adjust the data with + or – key for 820mVDC.
9. Press the MENU key to turn off the Service Menu display.
10. Check brightness level on every active channel, readjust (repeat steps 5 ~ 9), if necessary.

Note: Do not set to excessive brightness level, otherwise the contrast level will be suppressed.

HIGH VOLTAGE HOLD-DOWN TEST

Every time the receiver is serviced, the HIGH VOLTAGE HOLD-DOWN circuit must be tested for proper operation by following these steps:

1. Connect receiver to 120V AC line. Tune receiver to active channel. Reset the picture controls to the Sports levels.
2. Check that the voltage measured between TP7 and TE7 (ground side) is within 16.5 VDC to 21 VDC. If the voltage is out of this range, the Hold-Down Circuit must be checked.
3. Connect a DC Voltage supply to TP7 and TE7 through a 100 ohm 1/4W resistor. Adjust the DC voltage to 23 VDC. The receiver should shutdown, losing raster and sound. Then the receiver should turn off automatically. This reaction indicates that the Hold-Down circuit is functioning properly. If the receiver does not shutdown, a malfunction is indicated and its cause **must** be found and corrected.
4. To obtain picture again, remove the DC Supply and wait a few minutes. Now turn on the receiver.

HIGH VOLTAGE CHECK

Note: +B (+130V) Voltage Check and Grayscale Adjustment must be completed before attempting High Voltage Check.

1. Connect high voltage voltmeter – lead to ground, and connect + lead to anode of picture tube.
2. Tune receiver to an active channel and confirm TV is operating properly.
3. Eliminate the beam current by adjusting the contrast and brightness controls to minimum.
4. Confirm high voltage is within 28.0 KV and 30.0 KV. If reading is not within range, check horizontal circuit.

No high voltage adjustment is provided on this chassis.

SOUND ADJUSTMENT

1. Connect a color-bar generator to the antenna terminals with audio signal of 1KHz at 100% modulation.
2. Set the picture controls to the Sports levels
3. Connect oscilloscope + lead to TP21 (pin 75 of IC101) and – lead to ground.
4. Turn off the receiver and disconnect the AC power cord (AC 120V line).
5. While pressing the Menu key, reconnect the AC power cord. The Service Menu will now appear.
6. Select NO. 45 FL (FM Level) with the ▲ or ▼ key.
7. Adjust the data with the + or – key for an oscilloscope reading of $0.693 \pm 10\%$ VP-P at TP21.
8. Press the MENU key to turn off the Service Menu display and disconnect the oscilloscope from the chassis.

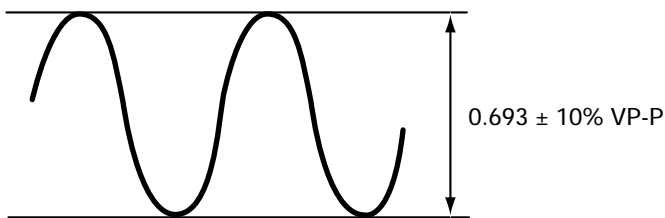

Figure 7.

MULTI-SOUND SECTION ADJUSTMENTS

Note: Multi-Sound Section must be adjusted after IC101 (Signal Processor), IC3401 (MTS Decoder), or IC802 (EEPROM) is replaced.

INPUT LEVEL ADJUSTMENT

1. Connect a signal to the antenna terminals with audio of 1 KHz 100% modulation.
2. Turn off the receiver and disconnect the AC power cord (AC 120V line).
3. Connect voltmeter (RMS) to TP317 and ground.
4. While pressing the Menu key, reconnect the AC power cord. The Service Menu will now appear.
5. Select NO. 60 ATT (Attenuation) with the ▲ or ▼ key.
6. Adjust the + or – key for a voltmeter reading of 400 ± 20 mVrms at TP317.

SEPARATION ADJUSTMENT

7. Turn off the receiver and disconnect the AC power cord (AC 120V line).
8. Connect oscilloscope CH1 to TP317 and CH2 to TP318 and ground.
9. Connect an MTS TV/Stereo generator to antenna terminal.
10. While pressing the Menu key, reconnect the AC power cord. The Service Menu will now appear.
11. Select pilot, 300Hz audio frequency and Left modulating signal.
12. Select NO. 61 WDB (Wideband) with the ▲ or ▼ key.
13. Adjust the + or – key for minimum low frequencies at TP317. (See Figure 8.)
14. Select 4 KHz audio frequency and Right modulating signal.
15. Select NO. 62 SPC (Spectral) with the ▲ or ▼ key.
16. Adjust the + or – key for minimum high frequencies at TP318. (See Figure 8.)

Repeat adjustments (steps 11–16) until no further decreases in amplitude can be obtained. Press the MENU key to turn off the Service Menu display.

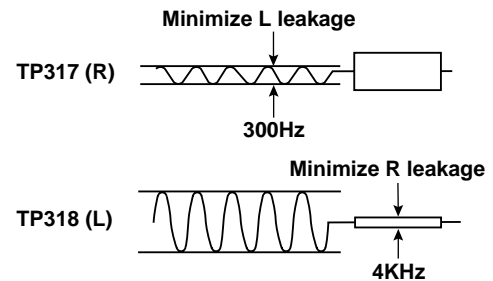

Figure 8. Separation Adjustments

PURITY AND CONVERGENCE ADJUSTMENTS

Purity and Convergence have been aligned at the factory. No re-alignment is necessary.

SERVICE HINTS

POWER FAILURE DETECTOR

This unit is equipped with a Power Failure Detector function included in the CPU which checks for an abnormal condition in the chassis power supplies, including the power supply derived from the Horizontal Output Transformer.

If, while the power is on, a failure is caused by any of the following that results in a low voltage supply, the CPU will turn the unit off in 1.5 seconds to prevent unnecessary damage:

- Failure within the power supply circuits.
- A short circuit in the load side from the supply.
- Stoppage of the Horizontal Output Oscillator caused by the X-Radiation protection Hold-Down Circuit.

If, while the power is off, the power is switched on and any of these failures remains uncorrected, the CPU will shut off the power within 3 seconds.

Check the following if the unit is turned off by the power failure detector.

1. Disconnect the AC power cord (120V AC line) for at least 10 seconds.
2. Connect a DC Voltmeter to the following TEST POINTS.

TJ4	26V
TJ6	5V
D429 Cathode	5V

3. Press the Power key and check for the proper voltage supplies.
4. If any of these voltages is low, the power failure detector should turn the unit off within 3 seconds.
5. Check all circuits listed above.

Note: This unit is equipped with a Power Surge Protection feature included in the CPU. If power failure occurs three times within 15 minutes, the CPU will automatically stop functioning to help prevent secondary damage. (TV will not turn on by pressing the power key.) To reset the operating programs within the CPU, disconnect the AC power cord for at least 10 seconds.

MECHANICAL DISASSEMBLIES

CABINET BACK REMOVAL

1. Refer to Figure 1, remove 9 screws.
2. Pull off cabinet back and remove.

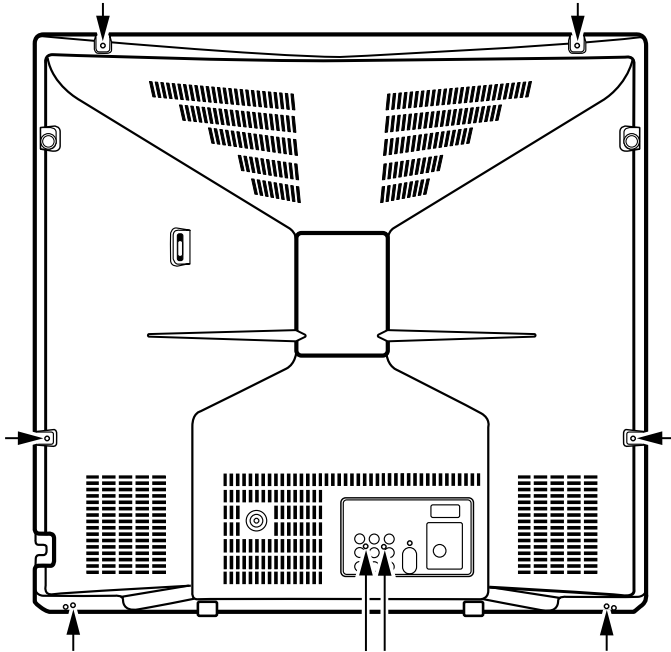

Figure 1. Cabinet Back Removal

CHASSIS REMOVAL

1. Remove cabinet back.
2. Discharge the picture tube anode (2nd anode lead) to the dag coating (picture tube grounding lead).
3. Disconnect degaussing coil socket (KD), picture tube socket, deflection yoke connector (KX), speakers connector (KSP), picture tube ground lead, and 2nd anode lead.
4. Remove chassis completely by sliding it straight back.

PICTURE TUBE REMOVAL

CAUTION: Do not disturb the deflection yoke or magnet assembly on the picture tube neck. Care must be taken to keep these assemblies intact, unless picture tube is being replaced. Discharge the picture tube to the coating before handling the tube.

1. Remove chassis, referring to Chassis Removal instructions.
2. Place cabinet's front face down on a soft surface.
3. Remove the screw on each corner of the picture tube and GENTLY lift the picture tube out of the cabinet.
4. Install a replacement picture tube in reverse order. Properly install the degaussing coil and picture tube grounding lead on the picture tube. See Figure 2.

Note: If Picture Tube is being replaced, mount the Degaussing Coil properly on the tube. See Figure 2.

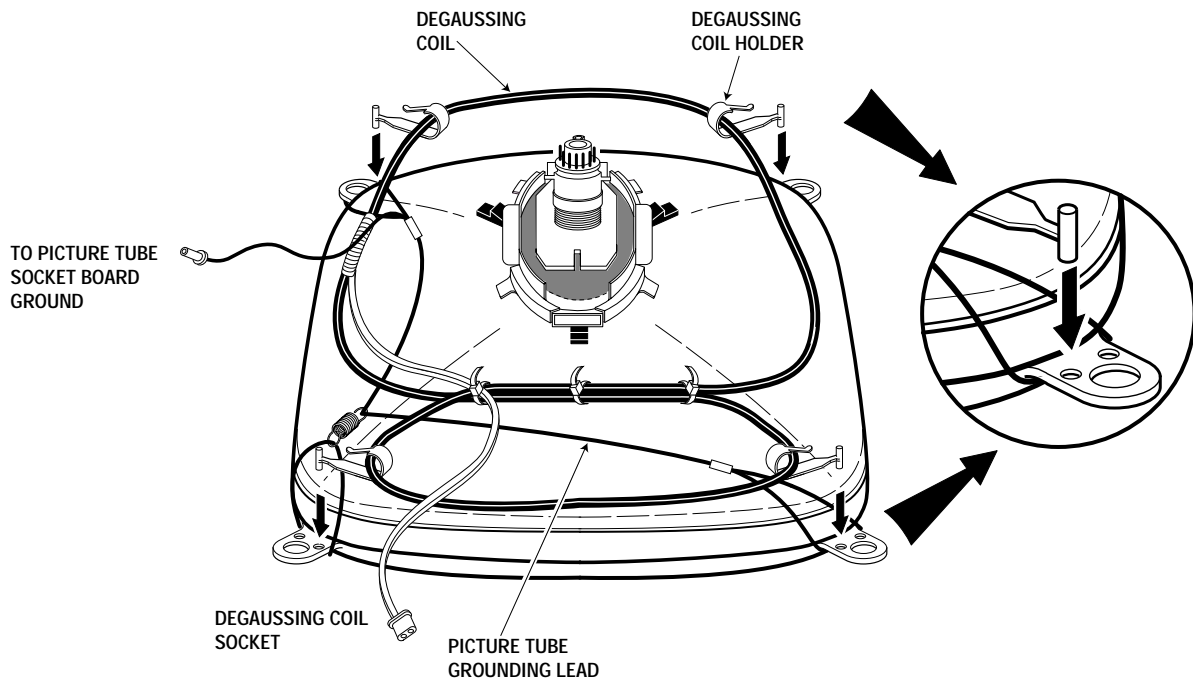

Figure 2. Picture Tube Removal

CHASSIS ELECTRICAL PARTS LIST

CAUTION: To Protect against electrical shock and for continued product safety, refer to SAFETY PRECAUTIONS, X-RADIATION PRECAUTIONS, HIGH VOLTAGE HOLD-DOWN TEST, and PRODUCT SAFETY NOTICE on Page 2.

PRODUCT SAFETY NOTICE

PRODUCT SAFETY SHOULD BE CONSIDERED WHEN A REPLACEMENT IS MADE IN ANY AREA OF A RECEIVER. COMPONENTS INDICATED BY A STAR (★) IN THIS PARTS LIST AND THE SCHEMATIC DIAGRAM DESIGNATE COMPONENTS IN WHICH SAFETY CAN BE OF SPECIAL SIGNIFICANCE. IT IS PARTICULARLY RECOMMENDED THAT ONLY PARTS DESIGNATED ON THE FOLLOWING PARTS LIST BE USED FOR COMPONENT REPLACEMENT DESIGNATED BY A STAR. NO DEVIATIONS FROM RESISTANCE, WATTAGE, AND VOLTAGE RATINGS MAY BE MADE FOR REPLACEMENT ITEMS DESIGNATED BY A STAR.

Notes: Parts having Location Number are located on the following boards.

- Numbers 700 SeriesOn the Picture Tube Socket Board.
- Numbers 900 SeriesOut of Board.
- All Other NumbersOn the Main Board

Note: Schematic part location numbers may not always match with the part descriptions.
The part descriptions are correct and should be used.

Schematic Location	Part No.	Description
--------------------	----------	-------------

Schematic Location	Part No.	Description
--------------------	----------	-------------

CAPACITORS

NOTES:

Read description of the Capacitor as follows:

(Example)

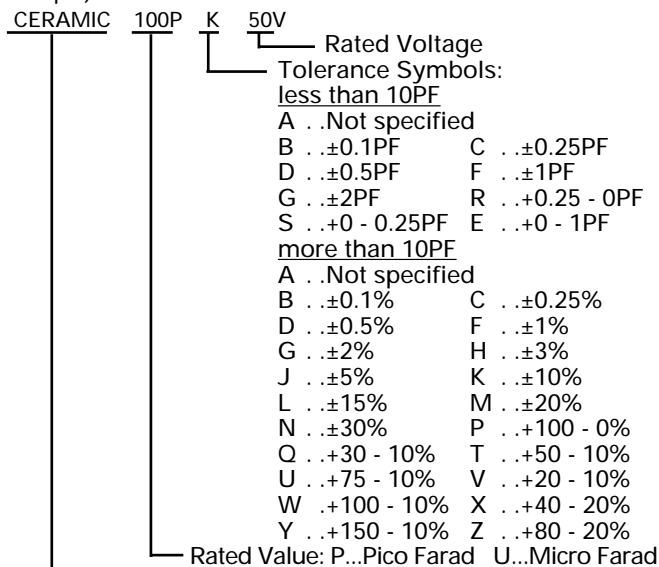

- Rated Voltage
- Tolerance Symbols:
- less than 10PF
- A . .Not specified
- B . .±0.1PF C . .±0.25PF
- D . .±0.5PF F . .±1PF
- G . .±2PF R . .±0.25 - 0PF
- S . .+0 - 0.25PF E . .+0 - 1PF
- more than 10PF
- A . .Not specified
- B . .±0.1% C . .±0.25%
- D . .±0.5% F . .±1%
- G . .±2% H . .±3%
- J . .±5% K . .±10%
- L . .±15% M . .±20%
- N . .±30% P . .+100 - 0%
- Q . .+30 - 10% T . .+50 - 10%
- U . .+75 - 10% V . .+20 - 10%
- W . .+100 - 10% X . .+40 - 20%
- Y . .+150 - 10% Z . .+80 - 20%
- Rated Value: P...Pico Farad U...Micro Farad

Material:

- CERAMICCeramic
- MT-PAPERMetalized Paper
- POLYESTERPolyester
- MT-POLYESTMetalized Polyester
- POLYPROPolypropylene
- MT-POLYPROMetalized Polypropylene
- COMPO-FILMComposite Film
- MT-COMPOMetalized Composite
- STYRENEStyrene
- TA-SOLIDTantalum Solid
- AL-SOLIDAluminum Solid
- ELECTElectrolytic
- NP-ELECTNon-Polarized Electrolytic
- OS-SOLIDAluminum Solid with Organic Semiconductive Electrolytic

C001	403 049 0008	ELECT	1U M	50V
C002	403 049 0008	ELECT	1U M	50V
C003	403 224 6009	CERAMIC	4700P K	50V
C004	403 224 6009	CERAMIC	4700P K	50V
C005	403 047 8402	ELECT	0.1U M	50V
C007	403 044 9501	ELECT	100U M	25V
C010	403 042 4805	ELECT	1000U M	16V
C011	403 042 4805	ELECT	1000U M	16V
C015	403 045 7803	ELECT	220U M	25V
C017	403 357 9601	CERAMIC	0.1U Z	50V
C101	403 038 6301	ELECT	220U M	6.3V
C103	403 224 6108	CERAMIC	0.01U K	50V
C106	403 050 6600	ELECT	3.3U M	50V
C131	403 049 0008	ELECT	1U M	50V
C133	403 224 6108	CERAMIC	0.01U K	50V
C134	403 224 5705	CERAMIC	1000P K	50V
C136	401 150 6001	MT-GLAZE	0.000 ZA	1/10W
C137	403 364 7508	CERAMIC	10P J	50V
C141	403 224 6108	CERAMIC	0.01U K	50V
C142	403 343 4603	CERAMIC	0.022U K	50V
C143	403 224 6108	CERAMIC	0.01U K	50V
C146	403 224 6108	CERAMIC	0.01U K	50V
C147	403 038 1603	ELECT	100U M	6.3V
C151	403 048 6308	ELECT	0.47U M	50V
C153	403 048 6308	ELECT	0.47U M	50V
C161	403 357 9601	CERAMIC	0.1U Z	50V
C211	403 086 2607	NP-ELECT	1U M	50V
C212	403 049 9803	ELECT	2.2U M	50V
C221	403 086 2607	NP-ELECT	1U M	50V
C251	401 150 6001	MT-GLAZE	0.000 ZA	1/10W
C252	403 062 0504	POLYESTER	0.047U K	50V
	403 312 2203	POLYESTER	0.047U K	50V

Schematic Location	Part No.	Description
C253	403 086 1808	NP-ELECT 0.47U M 50V
C256	403 049 0008	ELECT 1U M 50V
C257	403 224 6108	CERAMIC 0.01U K 50V
C258	403 043 9106	ELECT 47U M 16V
C272	403 050 6600	ELECT 3.3U M 50V
C274	403 041 8804	ELECT 10U M 16V
C284	403 041 8804	ELECT 10U M 16V
C285	403 224 6108	CERAMIC 0.01U K 50V
C301	403 041 8804	ELECT 10U M 16V
C302	403 041 8804	ELECT 10U M 16V
C303	403 357 9601	CERAMIC 0.1U Z 50V
C306	403 357 9601	CERAMIC 0.1U Z 50V
C313	403 357 9601	CERAMIC 0.1U Z 50V
C314	403 357 9601	CERAMIC 0.1U Z 50V
C316	403 357 9601	CERAMIC 0.1U Z 50V
C317	403 357 9601	CERAMIC 0.1U Z 50V
C322	403 357 9601	CERAMIC 0.1U Z 50V
C323	403 357 9601	CERAMIC 0.1U Z 50V
C401	403 044 1703	ELECT 470U M 16V
C402	403 224 6108	CERAMIC 0.01U K 50V
C403	403 063 0206	POLYESTER 6800P K 50V
	403 312 2807	POLYESTER 6800P K 50V
C405	403 086 2607	NP-ELECT 1U M 50V
C406	403 076 3607	CERAMIC 470P K 500V
C407	403 076 0507	CERAMIC 2200P K 500V
C408	403 055 0504	ELECT 1U M 160V
★ C410	403 324 3007	CERAMIC 680P K 3K
★ C412	403 343 7703	MT-POLYPRO0.012U H 1.5KV
	404 079 1607	MT-POLYPRO0.012U H 1.5KV
★ C416	403 349 3105	MT-POLYPRO 0.12U J 250V
	403 372 6203	MT-POLYPRO 0.12U J 250V
	404 081 7109	MT-POLYPRO0.12U M 200V
★ C417	403 346 6921	MT-POLYPRO 0.22U J 250V
	403 372 6609	MT-POLYPRO 0.22U J 250V
	404 081 2401	MT-POLYPRO0.22U M 200V
C421	403 038 6301	ELECT 220U M 6.3V
C426	403 038 9708	ELECT 330U M 6.3V
C427	403 224 6108	CERAMIC 0.01U K 50V
C441	403 224 6108	CERAMIC 0.01U K 50V
C473	403 067 7805	MT-COMPO 0.47U J 50V
C473	403 166 7706	MT-POLYEST 0.47U J 63V
C482	403 115 0703	ELECT 47U M 100V
C484	403 051 0607	ELECT 4.7U M 50V
C486	403 076 3607	CERAMIC 470P K 500V
C487	403 052 8503	ELECT 1000U M 35V
C489	403 044 1703	ELECT 470U M 16V
C493	404 056 5307	NP-ELECT 2.2U M 100V
C497	403 038 1603	ELECT 100U M 6.3V
C502	403 053 2104	ELECT 220U M 35V
C503	403 276 0208	ELECT 2.2U K 50V
C504	403 045 9807	ELECT 2200U M 25V
C505	403 067 7805	MT-COMPO 0.47U J 50V

Schematic Location	Part No.	Description
	403 166 7706	MT-POLYEST 0.47U J 63V
C506	403 062 5301	POLYESTER 5600P K 50V
	403 312 2401	POLYESTER 5600P K 50V
C508	403 235 0300	CERAMIC 56P J 50V
C509	403 067 7805	MT-COMPO 0.47U J 50V
C509	403 166 7706	MT-POLYEST 0.47U J 63V
★ C511	403 058 5407	POLYESTER 0.15U K 50V
	403 141 5802	POLYESTER 0.15U J 50V
C516	403 051 0607	ELECT 4.7U M 50V
★ C601	404 066 2204	MT-POLYEST 0.22U M 275V
	404 071 2404	MT-POLYEST 0.22U M 250V
★ C608	403 266 5008	CERAMIC 2700P K 1K
★ C609	404 075 5005	ELECT 470U M 200V
C612	403 067 6501	MT-COMPO 0.18U J 50V
	403 166 8208	MT-POLYEST 0.18U J 63V
C613	403 214 5203	POLYESTER 0.012U J 50V
	403 311 9203	POLYESTER 0.012U J 50V
C620	403 214 5203	POLYESTER 0.012U J 50V
	403 311 9203	POLYESTER 0.012U J 50V
C622	403 045 1504	ELECT 1000U M 25V
★ C625	403 266 5008	CERAMIC 2700P K 1K
C626	403 043 1902	ELECT 2200U M 16V
C628A	404 037 0703	ELECT 470U M 160V
C629	403 043 0202	ELECT 220U M 16V
C630	403 049 0008	ELECT 1U M 50V
★ C631	404 088 2909	CERAMIC 1000P M 250V
	404 088 7102	CERAMIC 1000P M 250V
★ C632	404 088 3005	CERAMIC 2200P M 250V
	404 088 7201	CERAMIC 2200P M 250V
C634	403 043 9106	ELECT 47U M 16V
C636	403 224 6108	CERAMIC 0.01U K 50V
C683	403 038 6301	ELECT 220U M 6.3V
C689	403 357 9601	CERAMIC 0.1U Z 50V
C693	403 047 8402	ELECT 0.1U M 50V
C701	403 224 5705	CERAMIC 1000P K 50V
C711	403 224 5705	CERAMIC 1000P K 50V
C721	403 224 5705	CERAMIC 1000P K 50V
C741	403 049 0008	ELECT 1U M 50V
★ C742	403 077 2807	CERAMIC 1000P Z 2K
C801	403 224 6108	CERAMIC 0.01U K 50V
C806	403 039 3507	ELECT 470U M 6.3V
C808	403 224 5507	CERAMIC 22P J 50V
C809	403 224 5507	CERAMIC 22P J 50V
C811	403 049 0008	ELECT 1U M 50V
C822	403 041 8804	ELECT 10U M 16V
C829	403 049 0008	ELECT 1U M 50V
C835	403 224 6108	CERAMIC 0.01U K 50V
C841	403 357 9601	CERAMIC 0.1U Z 50V
C842	403 357 9601	CERAMIC 0.1U Z 50V
C843	403 357 9601	CERAMIC 0.1U Z 50V
C853	403 047 8402	ELECT 0.1U M 50V
C854	403 235 0706	CERAMIC 120P J 50V

Schematic Location	Part No.	Description
C856	403 049 0008	ELECT 1U M 50V
C857	403 235 1000	CERAMIC 220P J 50V
C858	403 224 5705	CERAMIC 1000P K 50V
C862	403 224 6108	CERAMIC 0.01U K 50V
C1001	403 041 8804	ELECT 10U M 16V
C1002	403 042 7707	ELECT 22U M 16V
C1004	403 224 6108	CERAMIC 0.01U K 50V
C1005	403 224 6108	CERAMIC 0.01U K 50V
C1006	403 041 8804	ELECT 10U M 16V
C1011	403 224 6108	CERAMIC 0.01U K 50V
C1021	403 041 8804	ELECT 10U M 16V
C1032	403 043 0202	ELECT 220U M 16V
C1081	403 043 9106	ELECT 47U M 16V
C1091	403 224 6108	CERAMIC 0.01U K 50V
C1902	403 041 8804	ELECT 10U M 16V
C3401	403 047 8402	ELECT 0.1U M 50V
C3404	403 086 0108	NP-ELECT 4.7U M 25V
C3406	403 325 2504	CERAMIC 0.012U K 50V
C3407	403 235 5701	CERAMIC 5600P K 50V
C3408	403 048 6308	ELECT 0.47U M 50V
C3411	403 048 6308	ELECT 0.47U M 50V
C3412	403 043 9106	ELECT 47U M 16V
C3413	403 046 9905	ELECT 4.7U M 25V
C3414	403 042 2405	ELECT 100U M 16V
C3416	403 086 0108	NP-ELECT 4.7U M 25V
C3417	403 046 9905	ELECT 4.7U M 25V
C3418	403 086 0108	NP-ELECT 4.7U M 25V
C3421	403 224 5606	CERAMIC 2700P K 50V
C3422	403 323 3602	CERAMIC 0.047U K 50V
C3423	403 342 9203	TA-SOLID 3.3U K 10V
C3424	403 086 0108	NP-ELECT 4.7U M 25V
C3426	403 299 1820	TA-SOLID 10U K 10V
C3427	403 049 0008	ELECT 1U M 50V
C3431	403 224 6009	CERAMIC 4700P K 50V
C3432	403 047 8402	ELECT 0.1U M 50V
C3433	403 224 6009	CERAMIC 4700P K 50V
C3434	403 343 4603	CERAMIC 0.022U K 50V
C3435	403 046 9905	ELECT 4.7U M 25V
C3436	403 086 0108	NP-ELECT 4.7U M 25V
C3437	403 046 9905	ELECT 4.7U M 25V
C3439	403 086 0108	NP-ELECT 4.7U M 25V
C3442	403 046 9905	ELECT 4.7U M 25V
C3444	403 046 9905	ELECT 4.7U M 25V
C3446	403 046 9905	ELECT 4.7U M 25V
C3448	403 046 9905	ELECT 4.7U M 25V
C8002	403 043 9106	ELECT 47U M 16V
C8003	403 235 0409	CERAMIC 68P J 50V
C8005	403 234 9809	CERAMIC 18P J 50V
C8011	403 235 0409	CERAMIC 68P J 50V
C8012	403 296 0004	CERAMIC 0.1U K 25V
C8014	403 323 3602	CERAMIC 0.047U K 50V
C8015	403 319 4804	CERAMIC 0.22U Z 16V

Schematic Location	Part No.	Description
C8017	403 319 4804	CERAMIC 0.22U Z 16V
C8021	403 357 9601	CERAMIC 0.1U Z 50V
C8022	403 043 9106	ELECT 47U M 16V
C8023	403 357 9601	CERAMIC 0.1U Z 50V
C8024	403 043 9106	ELECT 47U M 16V
C8026	403 357 9601	CERAMIC 0.1U Z 50V
C8027	403 224 6108	CERAMIC 0.01U K 50V
C8028	403 224 6108	CERAMIC 0.01U K 50V
C8031	403 357 9601	CERAMIC 0.1U Z 50V
C8032	403 043 9106	ELECT 47U M 16V
C8033	403 357 9601	CERAMIC 0.1U Z 50V
C8034	403 224 6108	CERAMIC 0.01U K 50V
C8035	403 224 6108	CERAMIC 0.01U K 50V
C8036	403 041 8804	ELECT 10U M 16V
C8037	403 357 9601	CERAMIC 0.1U Z 50V
C8041	403 357 9601	CERAMIC 0.1U Z 50V
C8042	403 043 9106	ELECT 47U M 16V
C8049	403 357 9601	CERAMIC 0.1U Z 50V
C8051	403 235 0409	CERAMIC 68P J 50V
C8052	403 224 6108	CERAMIC 0.01U K 50V
C8053	403 235 0805	CERAMIC 150P J 50V
C8054	403 224 6108	CERAMIC 0.01U K 50V
C8055	403 357 9601	CERAMIC 0.1U Z 50V
C8056	403 357 9601	CERAMIC 0.1U Z 50V
C8057	403 357 9601	CERAMIC 0.1U Z 50V
C8058	403 224 6108	CERAMIC 0.01U K 50V
C8059	403 043 9106	ELECT 47U M 16V
C8060	403 296 0004	CERAMIC 0.1U K 25V
C8071	403 041 8804	ELECT 10U M 16V
C8072	403 041 8804	ELECT 10U M 16V
C8074	403 235 0607	CERAMIC 100P J 50V
C8076	403 235 0607	CERAMIC 100P J 50V
C8077	403 235 4902	CERAMIC 470P K 50V
C8081	403 048 6308	ELECT 0.47U M 50V
C8082	403 224 5804	CERAMIC 2200P K 50V
C8091	403 224 6108	CERAMIC 0.01U K 50V

DIODES

D101	407 056 2307	ZENER DIODE RD36EB1 (36V)
	407 100 0204	ZENER DIODE MTZJ36A (36V)
D351	407 056 8002	ZENER DIODE RD5.1EB2 (5.1)
	407 063 8606	ZENER DIODE MTZJ5.1A (5.1)
★ D421	407 158 1307	ZENER DIODE HZ11B2L (11V)
★ D422	407 158 1307	ZENER DIODE HZ11B2L (11V)
D428	407 054 5706	ZENER DIODE RD15EB1 (15V)
	407 099 6904	ZENER DIODE MTZJ15A (15V)
D429	407 013 4306	DIODE 1S2076A
	407 013 7109	DIODE 1S2473
	408 008 2406	DIODE 1N4148
D481	407 007 6606	DIODE ES1
	407 124 5506	DIODE RMPG06G

Schematic Location	Part No.	Description
	407 124 6404	DIODE ERA18-04
D482	407 011 4407	DIODE TVR1G
D483	407 007 6606	DIODE ES1
	407 124 5506	DIODE RMPG06G
	407 124 6404	DIODE ERA18-04
D486	407 054 0008	ZENER DIODE RD10EB2 (10V)
	407 099 6102	ZENER DIODE MTZJ10B (10V)
D487	407 005 8602	DIODE ERA15-02
	407 011 3004	DIODE S5277B
D487	407 088 6502	DIODE MPG06D
	408 009 9404	DIODE 1N4002ID
D490	407 057 0104	ZENER DIODE RD5.6EB3 (5.6V)
	407 063 8903	ZENER DIODE MTZJ5.6C (5.6V)
D501	407 005 8602	DIODE ERA15-02
	407 011 3004	DIODE S5277B
D501	407 088 6502	DIODE MPG06D
	408 009 9404	DIODE 1N4002ID
D503	407 056 2307	ZENER DIODE RD36EB1 (36V)
	407 100 0204	ZENER DIODE MTZJ36A (36V)
D508	407 013 4306	DIODE 1S2076A
	407 013 7109	DIODE 1S2473
	408 008 2406	DIODE 1N4148
★ D601	407 005 7605	DIODE EM2B
	407 013 3200	DIODE 1S1887A
	408 008 8606	DIODE GP15G
★ D602	407 005 7605	DIODE EM2B
	407 013 3200	DIODE 1S1887A
	408 008 8606	DIODE GP15G
★ D603	407 005 7605	DIODE EM2B
	407 013 3200	DIODE 1S1887A
	408 008 8606	DIODE GP15G
★ D604	407 005 7605	DIODE EM2B
	407 013 3200	DIODE 1S1887A
	408 008 8606	DIODE GP15G
D609	407 007 6903	DIODE ES1Z
	407 124 5605	DIODE RMPG06D
	407 124 6503	DIODE ERA18-02
	408 009 9008	DIODE BYD33D
D610	407 013 4306	DIODE 1S2076A
	407 013 7109	DIODE 1S2473
	408 008 2406	DIODE 1N4148
D611	407 057 0104	ZENER DIODE RD5.6EB3 (5.6V)
	407 063 8903	ZENER DIODE MTZJ5.6C (5.6V)
★ D612	407 104 2402	PHOTO COUPLE PC817C
	407 106 6101	PHOTO COUPLE PC817D
	407 147 5705	PHOTO COUPLE ON3131S
	407 175 9904	PHOTO COUPLE TLP621-1-BL
D614	407 013 4306	DIODE 1S2076A
	407 013 7109	DIODE 1S2473
	408 008 2406	DIODE 1N4148
★ D621	407 106 2806	DIODE RU3YX
★ D624	407 129 6706	DIODE RU4YX LF-L1

Schematic Location	Part No.	Description
	407 211 6102	DIODE FE301-1L43
★ D625	407 129 7000	DIODE RU4AM LF-L1
	407 211 5808	DIODE FE201-6L43
D627	407 013 4306	DIODE 1S2076A
	407 013 7109	DIODE 1S2473
	408 008 2406	DIODE 1N4148
D629	407 054 7007	ZENER DIODE RD16EB1 (16V)
	407 099 7208	ZENER DIODE MTZJ16A (16V)
D680	407 013 4306	DIODE 1S2076A
	407 013 7109	DIODE 1S2473
	408 008 2406	DIODE 1N4148
D683	407 013 4306	DIODE 1S2076A
	407 013 7109	DIODE 1S2473
	408 008 2406	DIODE 1N4148
D693	407 057 2702	ZENER DIODE RD6.2EB2 (6.2V)
	407 099 5402	ZENER DIODE MTZJ6.2B (6.2V)
D694	407 013 4306	DIODE 1S2076A
	407 013 7109	DIODE 1S2473
	408 008 2406	DIODE 1N4148
D801	407 013 4306	DIODE 1S2076A
	407 013 7109	DIODE 1S2473
	408 008 2406	DIODE 1N4148
D831	407 222 5903	ZD UDZS-TE-173.6B (3.6V)
D834	407 054 8509	ZENER DIODE RD18EB3 (18V)
	407 099 7703	ZENER DIODE MTZJ18C (18V)
D836	407 013 4306	DIODE 1S2076A
	407 013 7109	DIODE 1S2473
	408 008 2406	DIODE 1N4148
D843	407 013 4306	DIODE 1S2076A
	407 013 7109	DIODE 1S2473
	408 008 2406	DIODE 1N4148
D1001	407 054 0008	ZENER DIODE RD10EB2 (10V)
	407 099 6102	ZENER DIODE MTZJ10B (10V)
D1002	407 054 0008	ZENER DIODE RD10EB2 (10V)
	407 099 6102	ZENER DIODE MTZJ10B (10V)
D1006	407 054 0008	ZENER DIODE RD10EB2 (10V)
	407 099 6102	ZENER DIODE MTZJ10B (10V)
D1011	407 054 0008	ZENER DIODE RD10EB2 (10V)
	407 099 6102	ZENER DIODE MTZJ10B (10V)
D1021	407 054 0008	ZENER DIODE RD10EB2 (10V)
	407 099 6102	ZENER DIODE MTZJ10B (10V)
D1901	407 057 6502	ZENER DIODE RD7.5EB3 (7.5V)
	407 063 9306	ZENER DIODE MTZJ7.5C (7.5V)
D8000	407 099 4504	ZENER DIODE MTZJ3.9A (3.9A)
INTEGRATED CIRCUITS		
	IC001	409 389 4607 IC LA4600
	★ IC101	409 491 4809 IC LA76834NM-TBM
	IC301	409 491 5608 IC TDA9183T/N1
	★ IC501	409 340 1904 IC LA7841
	★ IC601	409 172 8102 IC SE130NH

Schematic Location	Part No.	Description
IC681	409 066 7303	IC UPC78L05J
	409 241 8309	IC TA78L05S
IC801	410 388 2006	IC M37272M8-XXXFP T4
IC802	409 333 3700	IC 24LC02B/P
	409 376 1503	IC ST24C02B6
	409 440 8902	IC M24C02-BN6
	409 495 6908	IC CAT24WC02P
	409 497 0706	IC S524C20D21-DCB0
IC1001	409 051 3006	IC TC4053BP
IC1002	409 051 3006	IC TC4053BP
IC3401	409 467 1108	IC CXA2134Q-T6
IC8001	409 466 6302	IC M65667SP
	COILS	
J8004	610 031 3873	INDUCTOR, 10U K
	645 016 2534	INDUCTOR, 10U K
★ LF601	645 042 7510	LINE FILTER
L164	645 003 9713	INDUCTOR, 15U K
	645 016 2657	INDUCTOR, 15U K
L301	645 008 2894	INDUCTOR, 5.6U K
	645 016 3104	INDUCTOR, 5.6U K
L302	645 008 2894	INDUCTOR, 5.6U K
	645 016 3104	INDUCTOR, 5.6U K
L303	645 008 2894	INDUCTOR, 5.6U K
	645 016 3104	INDUCTOR, 5.6U K
L304	645 008 2894	INDUCTOR, 5.6U K
	645 016 3104	INDUCTOR, 5.6U K
L401	645 036 4198	INDUCTOR, 1.0U, FILTER
★ L413	645 029 8042	COIL, LINEARITY
L601	610 078 6820	PIPE CORE
L621	610 078 5946	PIPE CORE
	652 000 1725	CORE, PIPE
L623	610 078 5946	PIPE CORE
	652 000 1725	CORE, PIPE
L625	610 078 5946	PIPE CORE
	652 000 1725	CORE, PIPE
L628	610 078 5946	PIPE CORE
	652 000 1725	CORE, PIPE
L801	645 008 2894	INDUCTOR, 5.6U K
	645 016 3104	INDUCTOR, 5.6U K
L821	645 008 2894	INDUCTOR, 5.6U K
	645 016 3104	INDUCTOR, 5.6U K
L851	645 008 2894	INDUCTOR, 5.6U K
	645 016 3104	INDUCTOR, 5.6U K
L881	645 006 2490	INDUCTOR, 1U K
	645 016 2411	INDUCTOR, 1U K
L882	645 006 2490	INDUCTOR, 1U K
	645 016 2411	INDUCTOR, 1U K
★ L901	645 044 9154	ASSY, COIL, DEGAUSSING
L1901	645 008 2894	INDUCTOR, 5.6U K
L1901	645 016 3104	INDUCTOR, 5.6U K
L8007	645 008 2894	INDUCTOR, 5.6U K

Schematic Location	Part No.	Description
	645 016 3104	INDUCTOR, 5.6U K
L8008	645 008 2894	INDUCTOR, 5.6U K
	645 016 3104	INDUCTOR, 5.6U K
L8022	610 031 3873	INDUCTOR, 10U K
	645 016 2534	INDUCTOR, 10U K
L8024	610 031 3873	INDUCTOR, 10U K
	645 016 2534	INDUCTOR, 10U K
L8032	610 031 3873	INDUCTOR, 10U K
	645 016 2534	INDUCTOR, 10U K
L8036	645 003 9676	INDUCTOR, 100U K
	645 016 2565	INDUCTOR, 100U K
L8059	610 031 3873	INDUCTOR, 10U K
	645 016 2534	INDUCTOR, 10U K
L8070	645 008 2894	INDUCTOR, 5.6U K
	645 016 3104	INDUCTOR, 5.6U K
L8074	645 003 9812	INDUCTOR, 33U K
	645 016 2985	INDUCTOR, 33U K
L8091	645 008 2894	INDUCTOR, 5.6U K
	645 016 3104	INDUCTOR, 5.6U K
L8094	645 006 2490	INDUCTOR, 1U K
	645 016 2411	INDUCTOR, 1U K
L8098	645 006 2490	INDUCTOR, 1U K
	645 016 2411	INDUCTOR, 1U K
	TRANSISTORS	
Q001	405 011 8401	TR 2SC1740S-Q
	405 011 8500	TR 2SC1740S-R
	405 011 8609	TR 2SC1740S-S
	405 012 2002	TR 2SC1815-GR
	405 012 2101	TR 2SC1815-O
	405 012 2309	TR 2SC1815-Y
	405 020 7501	TR 2SC945A-PA
	405 020 7709	TR 2SC945A-QA
	405 020 7907	TR 2SC945A-RA
	405 151 8705	TR 2SC536NG-NPA
	405 157 0505	TR 2SC536NF-NPA
Q135	405 011 8401	TR 2SC1740S-Q
	405 011 8500	TR 2SC1740S-R
	405 011 8609	TR 2SC1740S-S
	405 012 2002	TR 2SC1815-GR
	405 012 2101	TR 2SC1815-O
	405 012 2309	TR 2SC1815-Y
	405 020 7501	TR 2SC945A-PA
	405 020 7709	TR 2SC945A-QA
	405 020 7907	TR 2SC945A-RA
	405 151 8705	TR 2SC536NG-NPA
	405 157 0505	TR 2SC536NF-NPA
Q202	405 001 7407	TR 2SA1015-O(SAN)
	405 001 7605	TR 2SA1015-Y(SAN)
	405 004 3109	TR 2SA564A-Q(CU)
	405 004 3208	TR 2SA564A-R(CU)

Schematic Location	Part No.	Description
	405 006 1707	TR 2SA933S-Q
	405 006 1806	TR 2SA933S-R
	405 151 3304	TR 2SA608NF-NPA
Q208	406 000 6804	TR 2SA1015-GR(SAN)
	405 001 7407	TR 2SA1015-O(SAN)
	405 001 7605	TR 2SA1015-Y(SAN)
	405 004 3109	TR 2SA564A-Q(CU)
	405 004 3208	TR 2SA564A-R(CU)
	405 006 1707	TR 2SA933S-Q
	405 006 1806	TR 2SA933S-R
	405 151 3304	TR 2SA608NF-NPA
Q401	406 000 6804	TR 2SA1015-GR(SAN)
	405 013 6207	TR 2SC2271-D-CTV
	405 013 6306	TR 2SC2271-E-CTV
	405 029 7106	TR 2SC2271-D
	405 029 7205	TR 2SC2271-E
★ Q402	405 153 0202	TR 2SD2578-YB
Q446	405 001 7407	TR 2SA1015-O(SAN)
	405 001 7605	TR 2SA1015-Y(SAN)
	405 004 3109	TR 2SA564A-Q(CU)
	405 004 3208	TR 2SA564A-R(CU)
	405 006 1707	TR 2SA933S-Q
	405 006 1806	TR 2SA933S-R
	405 151 3304	TR 2SA608NF-NPA
Q486	406 000 6804	TR 2SA1015-GR(SAN)
	405 023 5009	TR 2SD400-E-MP
	405 023 5306	TR 2SD400-F-MP
Q490	405 023 5009	TR 2SD400-E-MP
	405 023 5306	TR 2SD400-F-MP
★ Q601	405 095 9004	TR 2SC4423-CTV
Q604	405 058 0208	TR 2SC3807-R-CTV-YA
Q605	405 001 7407	TR 2SA1015-O(SAN)
	405 001 7605	TR 2SA1015-Y(SAN)
	405 004 3109	TR 2SA564A-Q(CU)
	405 004 3208	TR 2SA564A-R(CU)
	405 006 1707	TR 2SA933S-Q
	405 006 1806	TR 2SA933S-R
	405 151 3304	TR 2SA608NF-NPA
Q627	406 000 6804	TR 2SA1015-GR(SAN)
	405 009 6907	TR 2SB985-S
	405 009 7003	TR 2SB985-T
	405 089 0000	TR 2SA1707-S
	405 089 0109	TR 2SA1707-T
Q635	405 011 8401	TR 2SC1740S-Q
	405 011 8500	TR 2SC1740S-R
	405 011 8609	TR 2SC1740S-S
	405 012 2002	TR 2SC1815-GR
	405 012 2101	TR 2SC1815-O
	405 012 2309	TR 2SC1815-Y
	405 020 7501	TR 2SC945A-PA
	405 020 7709	TR 2SC945A-QA
	405 020 7907	TR 2SC945A-RA

Schematic Location	Part No.	Description
	405 151 8705	TR 2SC536NG-NPA
	405 157 0505	TR 2SC536NF-NPA
Q681	405 011 8401	TR 2SC1740S-Q
	405 011 8500	TR 2SC1740S-R
	405 011 8609	TR 2SC1740S-S
	405 012 2002	TR 2SC1815-GR
	405 012 2101	TR 2SC1815-O
	405 012 2309	TR 2SC1815-Y
	405 020 7501	TR 2SC945A-PA
	405 020 7709	TR 2SC945A-QA
	405 020 7907	TR 2SC945A-RA
	405 151 8705	TR 2SC536NG-NPA
	405 157 0505	TR 2SC536NF-NPA
Q693	405 011 8401	TR 2SC1740S-Q
	405 011 8500	TR 2SC1740S-R
	405 011 8609	TR 2SC1740S-S
	405 012 2002	TR 2SC1815-GR
	405 012 2101	TR 2SC1815-O
	405 012 2309	TR 2SC1815-Y
	405 020 7501	TR 2SC945A-PA
	405 020 7709	TR 2SC945A-QA
	405 020 7907	TR 2SC945A-RA
	405 151 8705	TR 2SC536NG-NPA
	405 157 0505	TR 2SC536NF-NPA
Q695	405 001 7605	TR 2SA1015-Y(SAN)
	405 004 3208	TR 2SA564A-R(CU)
	405 151 3324	TR 2SA608NF-NPA-AT
Q701	405 041 6507	TR 2SC2621-D-RA
	405 041 6705	TR 2SC2621-E-RA
	405 066 4304	TR 2SC2621-C-RA
	405 066 9903	TR 2SC2688(1)-K
	405 067 0008	TR 2SC2688(1)-L
	405 067 0107	TR 2SC2688(1)-M
	406 000 3605	TR 2SC3620(LB-SAN-1)
Q711	405 041 6507	TR 2SC2621-D-RA
	405 041 6705	TR 2SC2621-E-RA
	405 066 4304	TR 2SC2621-C-RA
	405 066 9903	TR 2SC2688(1)-K
	405 067 0008	TR 2SC2688(1)-L
	405 067 0107	TR 2SC2688(1)-M
	406 000 3605	TR 2SC3620(LB-SAN-1)
Q721	405 041 6507	TR 2SC2621-D-RA
	405 041 6705	TR 2SC2621-E-RA
	405 066 4304	TR 2SC2621-C-RA
	405 066 9903	TR 2SC2688(1)-K
	405 067 0008	TR 2SC2688(1)-L
	405 067 0107	TR 2SC2688(1)-M
	406 000 3605	TR 2SC3620(LB-SAN-1)
Q831	405 001 7407	TR 2SA1015-O(SAN)
	405 001 7605	TR 2SA1015-Y(SAN)
	405 004 3109	TR 2SA564A-Q(CU)
	405 004 3208	TR 2SA564A-R(CU)

Schematic Location	Part No.	Description
	405 006 1707	TR 2SA933S-Q
	405 006 1806	TR 2SA933S-R
	405 151 3304	TR 2SA608NF-NPA
	406 000 6804	TR 2SA1015-GR(SAN)
Q1096	405 001 7407	TR 2SA1015-O(SAN)
	405 001 7605	TR 2SA1015-Y(SAN)
	405 004 3109	TR 2SA564A-Q(CU)
	405 004 3208	TR 2SA564A-R(CU)
	405 006 1707	TR 2SA933S-Q
	405 006 1806	TR 2SA933S-R
	405 151 3304	TR 2SA608NF-NPA
	406 000 6804	TR 2SA1015-GR(SAN)
Q1097	405 011 8401	TR 2SC1740S-Q
	405 011 8500	TR 2SC1740S-R
	405 011 8609	TR 2SC1740S-S
	405 012 2002	TR 2SC1815-GR
	405 012 2101	TR 2SC1815-O
	405 012 2309	TR 2SC1815-Y
	405 020 7501	TR 2SC945A-PA
	405 020 7709	TR 2SC945A-QA
	405 020 7907	TR 2SC945A-RA
	405 151 8705	TR 2SC536NG-NPA
	405 157 0505	TR 2SC536NF-NPA
Q8000	405 023 5009	TR 2SD400-E-MP
	405 023 5306	TR 2SD400-F-MP
Q8005	405 011 8401	TR 2SC1740S-Q
	405 011 8500	TR 2SC1740S-R
	405 011 8609	TR 2SC1740S-S
	405 012 2002	TR 2SC1815-GR
	405 012 2101	TR 2SC1815-O
	405 012 2309	TR 2SC1815-Y
	405 020 7501	TR 2SC945A-PA
	405 020 7709	TR 2SC945A-QA
	405 020 7907	TR 2SC945A-RA
	405 151 8705	TR 2SC536NG-NPA
	405 157 0505	TR 2SC536NF-NPA
Q8006	405 011 8401	TR 2SC1740S-Q
	405 011 8500	TR 2SC1740S-R
	405 011 8609	TR 2SC1740S-S
	405 012 2002	TR 2SC1815-GR
	405 012 2101	TR 2SC1815-O
	405 012 2309	TR 2SC1815-Y
	405 020 7501	TR 2SC945A-PA
	405 020 7709	TR 2SC945A-QA
	405 020 7907	TR 2SC945A-RA
	405 151 8705	TR 2SC536NG-NPA
	405 157 0505	TR 2SC536NF-NPA
Q8073	405 011 8401	TR 2SC1740S-Q
	405 011 8500	TR 2SC1740S-R
	405 011 8609	TR 2SC1740S-S
	405 012 2002	TR 2SC1815-GR
	405 012 2101	TR 2SC1815-O

Schematic Location	Part No.	Description
	405 012 2309	TR 2SC1815-Y
	405 020 7501	TR 2SC945A-PA
	405 020 7709	TR 2SC945A-QA
	405 020 7907	TR 2SC945A-RA
	405 151 8705	TR 2SC536NG-NPA
	405 157 0505	TR 2SC536NF-NPA
Q8076	405 001 7407	TR 2SA1015-O(SAN)
	405 001 7605	TR 2SA1015-Y(SAN)
	405 004 3109	TR 2SA564A-Q(CU)
	405 004 3208	TR 2SA564A-R(CU)
	405 006 1707	TR 2SA933S-Q
	405 006 1806	TR 2SA933S-R
	405 151 3304	TR 2SA608NF-NPA
	406 000 6804	TR 2SA1015-GR(SAN)
Q8083	405 001 7407	TR 2SA1015-O(SAN)
	405 001 7605	TR 2SA1015-Y(SAN)
	405 004 3109	TR 2SA564A-Q(CU)
	405 004 3208	TR 2SA564A-R(CU)
	405 006 1707	TR 2SA933S-Q
	405 006 1806	TR 2SA933S-R
	405 151 3304	TR 2SA608NF-NPA
	406 000 6804	TR 2SA1015-GR(SAN)
Q8090	405 011 8401	TR 2SC1740S-Q
	405 011 8500	TR 2SC1740S-R
	405 011 8609	TR 2SC1740S-S
	405 012 2002	TR 2SC1815-GR
	405 012 2101	TR 2SC1815-O
	405 012 2309	TR 2SC1815-Y
	405 020 7501	TR 2SC945A-PA
	405 020 7709	TR 2SC945A-QA
	405 020 7907	TR 2SC945A-RA
	405 151 8705	TR 2SC536NG-NPA
	405 157 0505	TR 2SC536NF-NPA
Q8093	405 017 1901	TR 2SC3114-T
	405 039 3303	TR 2SC3114-R
	405 039 3402	TR 2SC3114-S
Q8097	405 017 1901	TR 2SC3114-T
	405 039 3303	TR 2SC3114-R
	405 039 3402	TR 2SC3114-S

Schematic Location	Part No.	Description
--------------------	----------	-------------

RESISTORS

NOTES:

Read description of the Resistor as follows:

(Example)

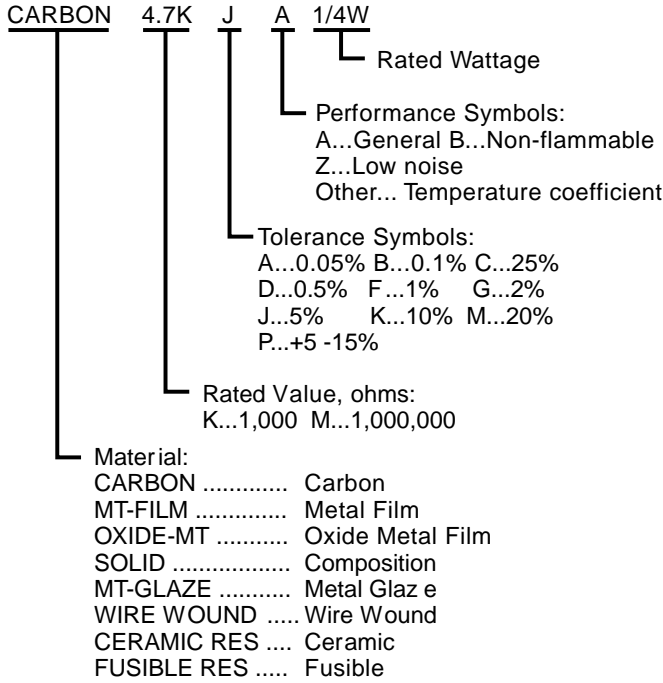

Schematic Location	Part No.	Description
--------------------	----------	-------------

R271	401 162 3401	MT-GLAZE 39K JA 1/10W
R272	401 027 5502	CARBON 6.8K JA 1/6W
R273	401 024 7400	CARBON 10K JA 1/6W
R274	401 162 4101	MT-GLAZE 5.6K JA 1/10W
R275	401 256 6608	MT-GLAZE 68K JA 1/10W
R276	401 024 9701	CARBON 12K JA 1/6W
R280	401 026 4902	CARBON 330K JA 1/6W
R281	401 150 5905	MT-GLAZE 10K JA 1/10W
R284	401 026 9303	CARBON 47 JA 1/6W
R287	401 255 6500	MT-GLAZE 100 JA 1/10W
R288	401 255 6500	MT-GLAZE 100 JA 1/10W
R289	401 255 6500	MT-GLAZE 100 JA 1/10W
R301	401 150 6001	MT-GLAZE 0.000 ZA 1/10W
R311	401 024 6700	CARBON 100 JA 1/6W
R312	401 162 4101	MT-GLAZE 5.6K JA 1/10W
R321	401 150 5905	MT-GLAZE 10K JA 1/10W
R323	401 256 4109	MT-GLAZE 56 JA 1/10W
R324	401 162 4101	MT-GLAZE 5.6K JA 1/10W
R326	401 256 4109	MT-GLAZE 56 JA 1/10W
R353	401 024 7400	CARBON 10K JA 1/6W
★ R401	401 012 4503	CARBON 100 JA 1/4W
★ R402	401 013 4205	CARBON 120 JA 1/4W
R404	401 026 3905	CARBON 330 JA 1/6W
R405	401 162 4101	MT-GLAZE 5.6K JA 1/10W
R406	401 010 8305	CARBON 5.6K JA 1/2W
★ R407	401 069 3702	OXIDE-MT 6.8K JA 2W
★ R411	402 083 6205	WIRE WOUND 6.8 KA 7W
R416	401 018 1605	CARBON 33 JA 1/4W
★ R418	401 009 1607	CARBON 2.7K JB 1/2W
★ R421	401 052 8608	MT-FILM 1.3K FA 1/6W
★ R422	401 052 6802	MT-FILM 10K FA 1/6W
★ R423	401 264 9301	MT-GLAZE 3.3K FA 1/10W
R426	401 256 6905	MT-GLAZE 680 JA 1/10W
R428	401 025 1902	CARBON 15K JA 1/6W
R441	401 024 7004	CARBON 1K JA 1/6W
R442	401 150 5905	MT-GLAZE 10K JA 1/10W
R443	401 026 9907	CARBON 4.7K JA 1/6W
R444	401 025 4606	CARBON 18K JA 1/6W
R446	401 150 6209	MT-GLAZE 1K JA 1/10W
R449	401 053 3206	MT-FILM 4.7K FA 1/6W
★ R481	401 009 4905	CARBON 33 JB 1/2W
★ R482	401 011 9004	CARBON 1 JB 1/4W
★ R483	401 006 7701	CARBON 1 JB 1/2W
R485	401 025 4606	CARBON 18K JA 1/6W
★ R486	401 068 6209	OXIDE-MT 5.6 JA 2W
R487	401 025 3807	CARBON 180 JA 1/6W
★ R488	401 059 1602	OXIDE-MT 15 JA 1W
★ R489	401 059 5907	OXIDE-MT 18 JA 1W
R491	401 012 5708	CARBON 1K JA 1/4W
R492	401 156 8504	MT-FILM 33K FA 1/6W
R493	401 017 3808	CARBON 270K JA 1/4W
R494	401 019 4001	CARBON 390K JA 1/4W

R001	401 024 9701	CARBON 12K JA 1/6W
R002	401 024 9701	CARBON 12K JA 1/6W
R003	401 256 3805	MT-GLAZE 1.5K JA 1/10W
R004	401 256 3805	MT-GLAZE 1.5K JA 1/10W
R008	401 026 9907	CARBON 4.7K JA 1/6W
R011	401 026 3905	CARBON 330 JA 1/6W
R012	401 027 2600	CARBON 5.6K JA 1/6W
★ R106	401 009 2000	CARBON 27K JA 1/2W
R131	401 256 1702	MT-GLAZE 33K JA 1/10W
R133	401 255 6401	MT-GLAZE 3K JA 1/10W
R135	401 150 6001	MT-GLAZE 0.000 ZA 1/10W
R137	401 150 6209	MT-GLAZE 1K JA 1/10W
R142	401 256 1702	MT-GLAZE 33K JA 1/10W
R143	401 150 6209	MT-GLAZE 1K JA 1/10W
R151	401 152 3206	MT-GLAZE 330 JA 1/10W
R161	401 150 5806	MT-GLAZE 100K JA 1/10W
R162	401 150 5806	MT-GLAZE 100K JA 1/10W
R163	401 256 0002	MT-GLAZE 120 JA 1/10W
R164	401 150 6209	MT-GLAZE 1K JA 1/10W
R166	401 256 7506	MT-GLAZE 390 JA 1/10W
R167	401 162 2701	MT-GLAZE 180 JA 1/10W
R201	401 026 9600	CARBON 470 JA 1/6W
R208	401 150 6209	MT-GLAZE 1K JA 1/10W
R212	401 256 7100	MT-GLAZE 680K JA 1/10W
R251	401 256 5304	MT-GLAZE 56K JA 1/10W
R252	401 256 3607	MT-GLAZE 15K JA 1/10W

Schematic Location	Part No.	Description
★ R495	401 066 5204	OXIDE-MT 22 JA 2W
★ R497	401 059 9608	OXIDE-MT 2.2 JA 1W
R499	401 026 6609	CARBON 390 JA 1/6W
R503	401 026 7002	CARBON 3.9K JA 1/6W
R504	401 027 8602	CARBON 8.2K JA 1/6W
R505	401 006 8401	CARBON 1.5 JA 1/2W
R506	401 025 7409	CARBON 220 JA 1/6W
R507	401 006 8401	CARBON 1.5 JA 1/2W
R508	401 025 4606	CARBON 18K JA 1/6W
R509	401 025 4606	CARBON 18K JA 1/6W
★ R511	401 065 2808	OXIDE-MT 120 JA 2W
R512	401 012 5708	CARBON 1K JA 1/4W
R517	401 027 0309	CARBON 47K JA 1/6W
R518	401 256 7209	MT-GLAZE 18K JA 1/10W
★ R601	402 083 6106	WIRE WOUND 1 KA 7W
★ R602	402 000 1603	SOLID 3.3M MA 1/2W
	402 088 1502	RESISTER 3.3M JA 1/2W
R603	401 007 2309	CARBON 100K JA 1/2W
★ R604	401 066 5204	OXIDE-MT 22 JA 2W
★ R606	401 066 5204	OXIDE-MT 22 JA 2W
★ R613	401 066 9103	OXIDE-MT 27 JA 2W
R614	401 011 1107	CARBON 68 JA 1/2W
R615	401 014 5201	CARBON 15K JA 1/4W
R616	401 026 0904	CARBON 2.7K GA 1/6W
R617	401 026 0904	CARBON 2.7K GA 1/6W
★ R618	401 066 9103	OXIDE-MT 27 JA 2W
R619	401 025 8208	CARBON 22K JA 1/6W
R620	401 027 2600	CARBON 5.6K JA 1/6W
R621	401 162 3708	MT-GLAZE 4.7K JA 1/10W
R622	401 158 2708	CARBON 2K GA 1 /6W
R627	401 024 7400	CARBON 10K JA 1/6W
R628	401 013 5301	CARBON 1.2K JA 1/4W
R629	401 150 6209	MT-GLAZE 1K JA 1/10W
★ R630	401 060 5002	OXIDE-MT 22K JA 1W
R631	401 022 3107	CARBON 6.8K JA 1/4W
R632	401 150 6209	MT-GLAZE 1K JA 1/10W
R634	401 256 6301	MT-GLAZE 47K JA 1/10W
R683	401 026 9907	CARBON 4.7K JA 1/6W
R686	401 016 1508	CARBON 22 JA 1/4W
R691	401 024 7400	CARBON 10K JA 1/6W
R692	401 027 5908	CARBON 68K JA 1/6W
R693	401 027 3201	CARBON 560K JA 1/6W
R694	401 024 7400	CARBON 10K JA 1/6W
R695	401 025 8208	CARBON 22K JA 1/6W
R701	401 025 3807	CARBON 180 JA 1/6W
R703	401 039 0304	MT-GLAZE 820 JA 1/10W
R704	401 027 8107	CARBON 82 JA 1/6W
R706	401 009 1508	CARBON 2.7K JA 1/2W
★ R707	401 065 4604	OXIDE-MT 12K JA 2W
R711	401 025 3807	CARBON 180 JA 1/6W
R713	401 039 0304	MT-GLAZE 820 JA 1/10W
R714	401 039 0205	MT-GLAZE 82 JA 1/10W

Schematic Location	Part No.	Description
R716	401 009 1508	CARBON 2.7K JA 1/2W
★ R717	401 065 4604	OXIDE-MT 12K JA 2W
R721	401 025 3807	CARBON 180 JA 1/6W
R723	401 039 0304	MT-GLAZE 820 JA 1/10W
R724	401 027 8107	CARBON 82 JA 1/6W
R726	401 009 1508	CARBON 2.7K JA 1/2W
★ R727	401 065 4604	OXIDE-MT 12K JA 2W
R803	401 024 6700	CARBON 100 JA 1/6W
R804	401 024 6700	CARBON 100 JA 1/6W
R806	401 162 3708	MT-GLAZE 4.7K JA 1/10W
R807	401 150 5905	MT-GLAZE 10K JA 1/10W
R808	401 150 5905	MT-GLAZE 10K JA 1/10W
R809	401 162 3708	MT-GLAZE 4.7K JA 1/10W
R810	401 024 7400	CARBON 10K JA 1/6W
R813	401 150 5905	MT-GLAZE 10K JA 1/10W
R814	401 150 5905	MT-GLAZE 10K JA 1/10W
R816	401 152 3206	MT-GLAZE 330 JA 1/10W
R824	401 255 6500	MT-GLAZE 100 JA 1/10W
R829	401 255 6500	MT-GLAZE 100 JA 1/10W
R831	401 150 5806	MT-GLAZE 100K JA 1/10W
R833	401 150 5905	MT-GLAZE 10K JA 1/10W
R835	401 026 1000	CARBON 2.7K JA 1/6W
R841	401 150 6209	MT-GLAZE 1K JA 1/10W
R842	401 256 0309	MT-GLAZE 820 JA 1/10W
R843	401 256 0309	MT-GLAZE 820 JA 1/10W
R844	401 256 0309	MT-GLAZE 820 JA 1/10W
R846	401 150 6209	MT-GLAZE 1K JA 1/10W
R847	401 162 4101	MT-GLAZE 5.6K JA 1/10W
R848	401 162 4101	MT-GLAZE 5.6K JA 1/10W
R849	401 162 4101	MT-GLAZE 5.6K JA 1/10W
R851	401 150 6209	MT-GLAZE 1K JA 1/10W
R852	401 026 7408	CARBON 39K JA 1/6W
R853	401 255 6005	MT-GLAZE 1M JA 1/10W
R854	401 150 6100	MT-GLAZE 2.2K JA 1/10W
R856	401 255 6500	MT-GLAZE 100 JA 1/10W
R857	401 255 6500	MT-GLAZE 100 JA 1/10W
R862	401 255 6500	MT-GLAZE 100 JA 1/10W
R864	401 256 0200	MT-GLAZE 120K JA 1/10W
R872	401 256 3607	MT-GLAZE 15K JA 1/10W
R873	401 162 3005	MT-GLAZE 22K JA 1/10W
R881	401 255 6500	MT-GLAZE 100 JA 1/10W
R882	401 255 6500	MT-GLAZE 100 JA 1/10W
R883	401 255 6500	MT-GLAZE 100 JA 1/10W
R884	401 255 6500	MT-GLAZE 100 JA 1/10W
R886	401 150 5905	MT-GLAZE 10K JA 1/10W
R1001	401 256 2709	MT-GLAZE 75 JA 1/10W
R1002	401 256 2709	MT-GLAZE 75 JA 1/10W
R1006	401 026 9600	CARBON 470 JA 1/6W
R1007	401 026 9907	CARBON 4.7K JA 1/6W
R1011	401 256 2709	MT-GLAZE 75 JA 1/10W
R1012	401 256 6004	MT-GLAZE 27K JA 1/10W
R1013	401 024 9701	CARBON 12K JA 1/6W

Schematic Location	Part No.	Description
R1021	401 256 2709	MT-GLAZE 75 JA 1/10W
R1041	401 162 3005	MT-GLAZE 22K JA 1/10W
R1042	401 162 3005	MT-GLAZE 22K JA 1/10W
R1046	401 150 5905	MT-GLAZE 10K JA 1/10W
R1047	401 256 6004	MT-GLAZE 27K JA 1/10W
R1048	401 150 5905	MT-GLAZE 10K JA 1/10W
R1049	401 256 6004	MT-GLAZE 27K JA 1/10W
R1082	401 162 3005	MT-GLAZE 22K JA 1/10W
R1096	401 150 5905	MT-GLAZE 10K JA 1/10W
R1097	401 024 7400	CARBON 10K JA 1/6W
R1098	401 150 6209	MT-GLAZE 1K JA 1/10W
R1901	401 150 5905	MT-GLAZE 10K JA 1/10W
R1902	401 150 6209	MT-GLAZE 1K JA 1/10W
R1903	401 162 2800	MT-GLAZE 1.8K JA 1/10W
R1904	401 150 6100	MT-GLAZE 2.2K JA 1/10W
R1905	401 256 7605	MT-GLAZE 3.9K JA 1/10W
R1906	401 162 4101	MT-GLAZE 5.6K JA 1/10W
R1907	401 256 0408	MT-GLAZE 12K JA 1/10W
R1909	401 024 7004	CARBON 1K JA 1/6W
R1910	401 024 7004	CARBON 1K JA 1/6W
R3401	401 025 7409	CARBON 220 JA 1/6W
R3402	401 025 7409	CARBON 220 JA 1/6W
R3406	401 150 5806	MT-GLAZE 100K JA 1/10W
R3407	401 255 6005	MT-GLAZE 1M JA 1/10W
R3411	401 265 4008	MT-GLAZE 62K JA 1/10W
R3421	401 162 3104	MT-GLAZE 3.3K JA 1/10W
R3422	401 255 6401	MT-GLAZE 3K JA 1/10W
R3426	401 256 7605	MT-GLAZE 3.9K JA 1/10W
R3432	401 150 5905	MT-GLAZE 10K JA 1/10W
R3433	401 150 5905	MT-GLAZE 10K JA 1/10W
R3434	401 162 4002	MT-GLAZE 560 JA 1/10W
R3435	401 150 5806	MT-GLAZE 100K JA 1/10W
R3436	401 162 4002	MT-GLAZE 560 JA 1/10W
R3437	401 150 5806	MT-GLAZE 100K JA 1/10W
R3441	401 256 1405	MT-GLAZE 330K JA 1/10W
R3442	401 255 6500	MT-GLAZE 100 JA 1/10W
R3443	401 256 1405	MT-GLAZE 330K JA 1/10W
R3444	401 255 6500	MT-GLAZE 100 JA 1/10W
R3445	401 256 1405	MT-GLAZE 330K JA 1/10W
R3446	401 255 6500	MT-GLAZE 100 JA 1/10W
R3447	401 256 1405	MT-GLAZE 330K JA 1/10W
R3448	401 024 6700	CARBON 100 JA 1/6W
★ R8001	401 068 6902	OXIDE-MT 56 JA 2W
★ R8002	401 064 7507	OXIDE-MT 100 JA 2W
R8003	401 256 6301	MT-GLAZE 47K JA 1/10W
R8004	401 256 6301	MT-GLAZE 47K JA 1/10W
R8005	401 162 3708	MT-GLAZE 4.7K JA 1/10W
R8006	401 162 3708	MT-GLAZE 4.7K JA 1/10W
R8009	401 026 9600	CARBON 470 JA 1/6W
R8011	401 255 7002	MT-GLAZE 51 JA 1/10W
R8012	401 255 6609	MT-GLAZE 300 JA 1/10W
R8013	401 150 5806	MT-GLAZE 100K JA 1/10W

Schematic Location	Part No.	Description
R8014	401 255 9600	MT-GLAZE 820K JA 1/10W
R8015	401 255 5800	MT-GLAZE 2K JA 1/10W
R8036	401 150 5806	MT-GLAZE 100K JA 1/10W
R8037	401 256 3607	MT-GLAZE 15K JA 1/10W
R8043	401 256 3607	MT-GLAZE 15K JA 1/10W
R8044	401 256 3607	MT-GLAZE 15K JA 1/10W
R8055	401 256 4901	MT-GLAZE 360 JA 1/10W
R8056	401 162 3609	MT-GLAZE 470 JA 1/10W
R8061	401 256 3607	MT-GLAZE 15K JA 1/10W
R8065	610 031 3873	INDUCTOR, 10U K
R8065	645 016 2534	INDUCTOR, 10U K
R8071	401 162 3005	MT-GLAZE 22K JA 1/10W
R8072	401 162 3005	MT-GLAZE 22K JA 1/10W
R8073	401 150 6209	MT-GLAZE 1K JA 1/10W
R8074	401 150 6209	MT-GLAZE 1K JA 1/10W
R8076	401 256 6202	MT-GLAZE 270 JA 1/10W
R8077	401 256 6905	MT-GLAZE 680 JA 1/10W
R8081	401 152 3206	MT-GLAZE 330 JA 1/10W
R8082	401 256 6608	MT-GLAZE 68K JA 1/10W
R8083	401 256 1405	MT-GLAZE 330K JA 1/10W
R8084	401 150 6001	MT-GLAZE 0.000 ZA 1/10W
R8085	401 256 3805	MT-GLAZE 1.5K JA 1/10W
R8088	401 256 3607	MT-GLAZE 15K JA 1/10W
R8089	401 256 3607	MT-GLAZE 15K JA 1/10W
R8090	401 025 8208	CARBON 22K JA 1/6W
R8091	401 150 5905	MT-GLAZE 10K JA 1/10W
R8092	401 256 7209	MT-GLAZE 18K JA 1/10W
R8093	401 256 6301	MT-GLAZE 47K JA 1/10W
R8095	401 150 5905	MT-GLAZE 10K JA 1/10W
R8096	401 256 7209	MT-GLAZE 18K JA 1/10W
R8097	401 256 6301	MT-GLAZE 47K JA 1/10W
SWITCHES		
SW1901	645 006 9673	SWITCH, PUSH (POWER)
	645 027 7382	SWITCH, PUSH (POWER)
	645 052 2284	SWITCH, PUSH (POWER)
SW1902	645 006 9673	SWITCH, PUSH (VOL +)
	645 027 7382	SWITCH, PUSH (VOL +)
	645 052 2284	SWITCH, PUSH (VOL +)
SW1903	645 006 9673	SWITCH, PUSH (VOL -)
	645 027 7382	SWITCH, PUSH (VOL -)
	645 052 2284	SWITCH, PUSH (VOL -)
SW1904	645 006 9673	SWITCH, PUSH (CH ▲)
	645 027 7382	SWITCH, PUSH (CH ▲)
	645 052 2284	SWITCH, PUSH (CH ▲)
SW1905	645 006 9673	SWITCH, PUSH (CH ▼)
	645 027 7382	SWITCH, PUSH (CH ▼)
	645 052 2284	SWITCH, PUSH (CH ▼)
SW1906	645 006 9673	SWITCH, PUSH (MENU)
	645 027 7382	SWITCH, PUSH (MENU)
	645 052 2284	SWITCH, PUSH (MENU)

Schematic Location	Part No.	Description
--------------------	----------	-------------

TRANSFORMERS

T151	645 049 3775	TRANS, OSC 45.75MHZ
T401	610 000 1138	DRIVE TRANS
	610 223 1663	DRIVE TRANS
★ T402	645 018 9579	TRANS, FLYBACK
	645 032 8978	TRANS, FLYBACK
★ T601	645 040 1510	TRANS, POWER, PULSE

CRYSTAL/FILTERS

X141	421 008 9008	SAW F TSF5235P
X161	610 015 3059	TRAP, CERAMIC 4.5MHZ
	645 041 1618	TRAP CERAMIC 4.5MHZ
X251	610 012 0655	CRYSTAL OSCILLATOR
	610 204 4195	CRYSTAL OSCILLATOR
	610 245 9746	CRYSTAL OSCILLATOR
X801	645 026 8434	OSC, CRYSTAL 8.000MHZ
X8011	645 041 1564	OSC, CRYSTAL 14.31818MHZ

MISCELLANEOUS

A001	610 295 6818	ASSY, PWB, MAIN
★ A101	645 052 6084	TUNER, U/V
A701	610 289 6183	ASSY, PWB, SOCKET
A1901	645 047 6228	UNIT, REMOCON RECEIVER
★ F601	423 007 1601	FUSE 125V 4A
	423 007 1809	FUSE 125V 4A
	423 018 8101	FUSE 125V 4A
	423 029 8008	FUSE 125V 4A

Schematic Location	Part No.	Description
--------------------	----------	-------------

F601A	645 000 5077	HOLDER, FUSE
	645 016 0479	HOLDER, FUSE
F601B	645 000 5077	HOLDER, FUSE
	645 016 0479	HOLDER, FUSE
K1001	645 043 7007	JACK, RCA-8(9-1)
K1051	645 050 8882	SOCKET, DIN 4PX2
★ K701	645 025 6103	SOCKET, CRT 8P
	645 028 0306	SOCKET, CRT 8P
★ PS601	408 046 5209	TH PTDA A1BF3R0Q100
★ Q901	414 010 3409	CRT A68AJB82X04
★ RL601	645 000 4155	RELAY
	645 011 2713	RELAY
	645 015 8629	RELAY
	645 024 7767	RELAY
	645 024 7828	RELAY
	645 052 5933	RELAY
SP901	645 028 0870	SPEAKER, 8
SP902	645 028 0870	SPEAKER, 8
★ W601	645 030 5290	CORD, POWER-2.0MK
★ W901	610 270 5393	ASSY, WIRE GND CONNECTOR
	610 271 6146	GROUND CONNECTOR

CABINET PARTS LIST

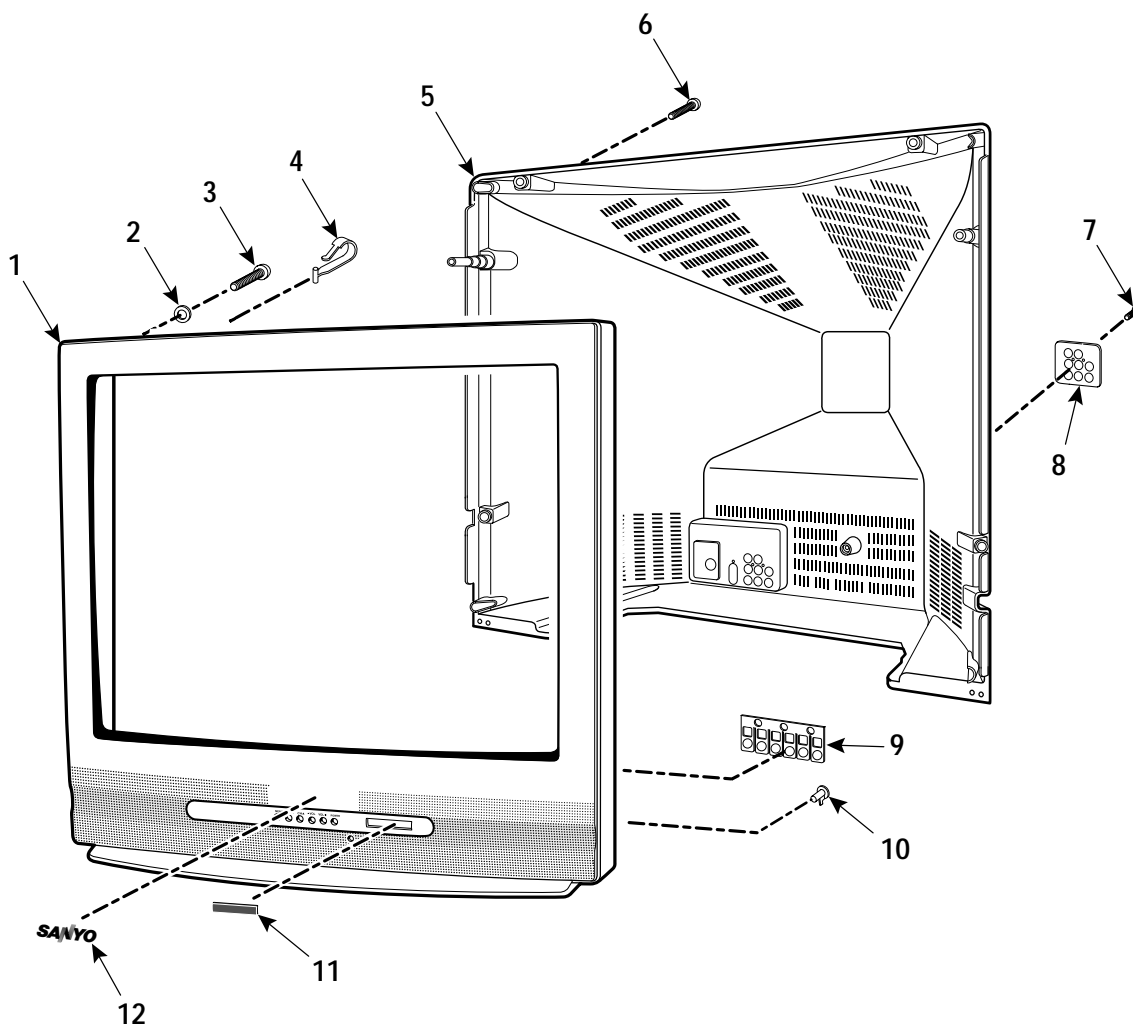

CABINET PARTS LIST

ACCESSORY PARTS LIST

KEY NO.	PARTS NO.	DESCRIPTION
1	610 296 4578	CABINET FRONT ASSY
2	610 268 9624	CRT MTG WASHER 1.6MM (4 USED)
3	412 053 3905	CRT MTG SCREW 6X35 (4 USED)
OR	412 054 0002	CRT MTG SCREW 6X35 (4 USED)
4	610 102 7151	DC HOLDER (4 USED)
5	610 296 4592	CABINET BACK
6	412 036 1805	SCREW 4X14 (6 USED)
OR	411 078 1101	SCREW 4X14 (6 USED)
7	411 026 2303	SCREW 3X10 (2 USED)
8	610 297 6120	DEC AV SHEET
9	610 96 7258	BUTTON UNIT
10	610 285 1199	CAP RC
11	610 299 5763	DEC SHEET
12	610 293 2560	SANYO BADGE

KEY NO.	PARTS NO.	DESCRIPTION
	610 297 8933	OWNER'S MANUAL
	645 053 8704	RC TRANSMITTER
	610 290 1344	RC BATTERY COVER

COMPONENT AND TESTPOINT LOCATIONS

MAIN BOARD FOIL SIDE

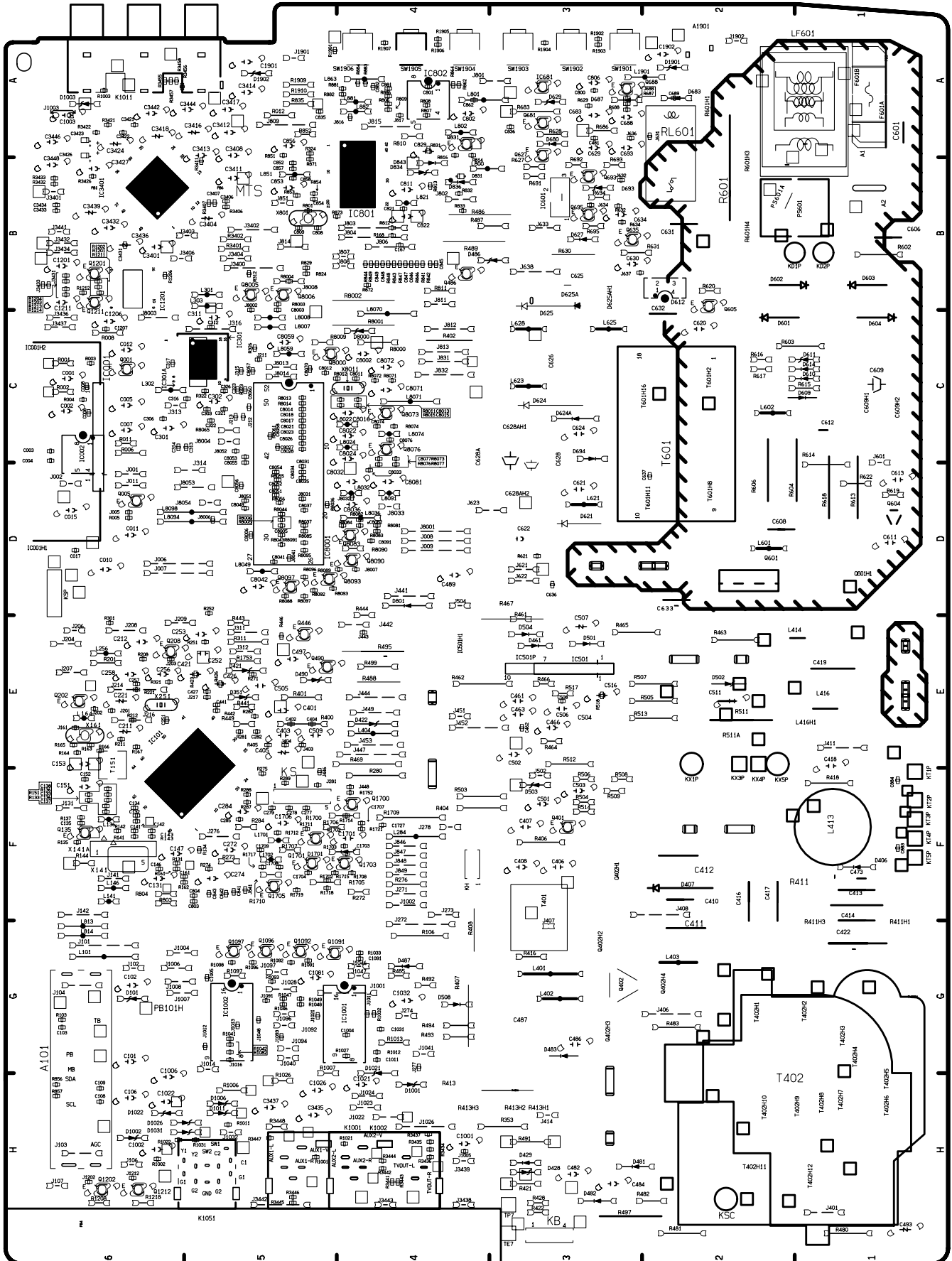

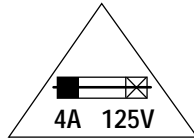
CAUTION

FOR CONTINUED PROTECTION AGAINST A RISK OF FIRE,
REPLACE ONLY WITH THE SAME TYPE 4A, 125V FUSE.

ATTENTION : POUR MAINTENIR LA PROTECTION CONTRE
LES RISQUES D' INCENDIE UTILISER UN FUSIBLE DE
RECHANGE DE MEME TYPE 4A, 125V.

**MAIN BOARD COMPONENTS AND TEST POINTS
GRID LOCATIONS**

Part	Loc.	Part	Loc.	Part	Loc.
D429	H3	Q401	F3	Q8073	C4
D612	B2	Q402	G3	Q8076	C4
D801	D4	Q446	E5	Q8083	D4
IC001	C6	Q486	B4	Q8090	D4
IC101	E6	Q490	E5	Q8093	D5
IC501	E3	Q601	D2	Q8097	D5
IC601	B3	Q604	D1	R513	E3
IC681	A3	Q605	C2	TE7	H3
IC801	B4	Q627	A3	TP7	H3
IC802	A4	Q635	B3	TJ1	B3
IC1001	G4	Q681	A3	TJ4	F3
IC1002	G5	Q693	B3	TJ5	B4
IC3401	B6	Q695	B3	TP16	E6
IC8001	C5	Q831	A4	TP21	F6
Q001	C6	Q1096	G5	TP50	H3
Q005	D6	Q1097	G5	TP51	H3
Q135	F6	Q8000	C5	TP317	B6
Q202	E6	Q8005	B5	TP318	B6
Q208	E6	Q8006	B5	T151	E6

PIC TUBE SOCKET BOARD COMPONENTS

Part	Loc.
Q701	N/A
Q711	N/A
Q721	N/A

COMPONENT AND TESTPOINT LOCATIONS (Cont.)

MAIN BOARD PARTS SIDE

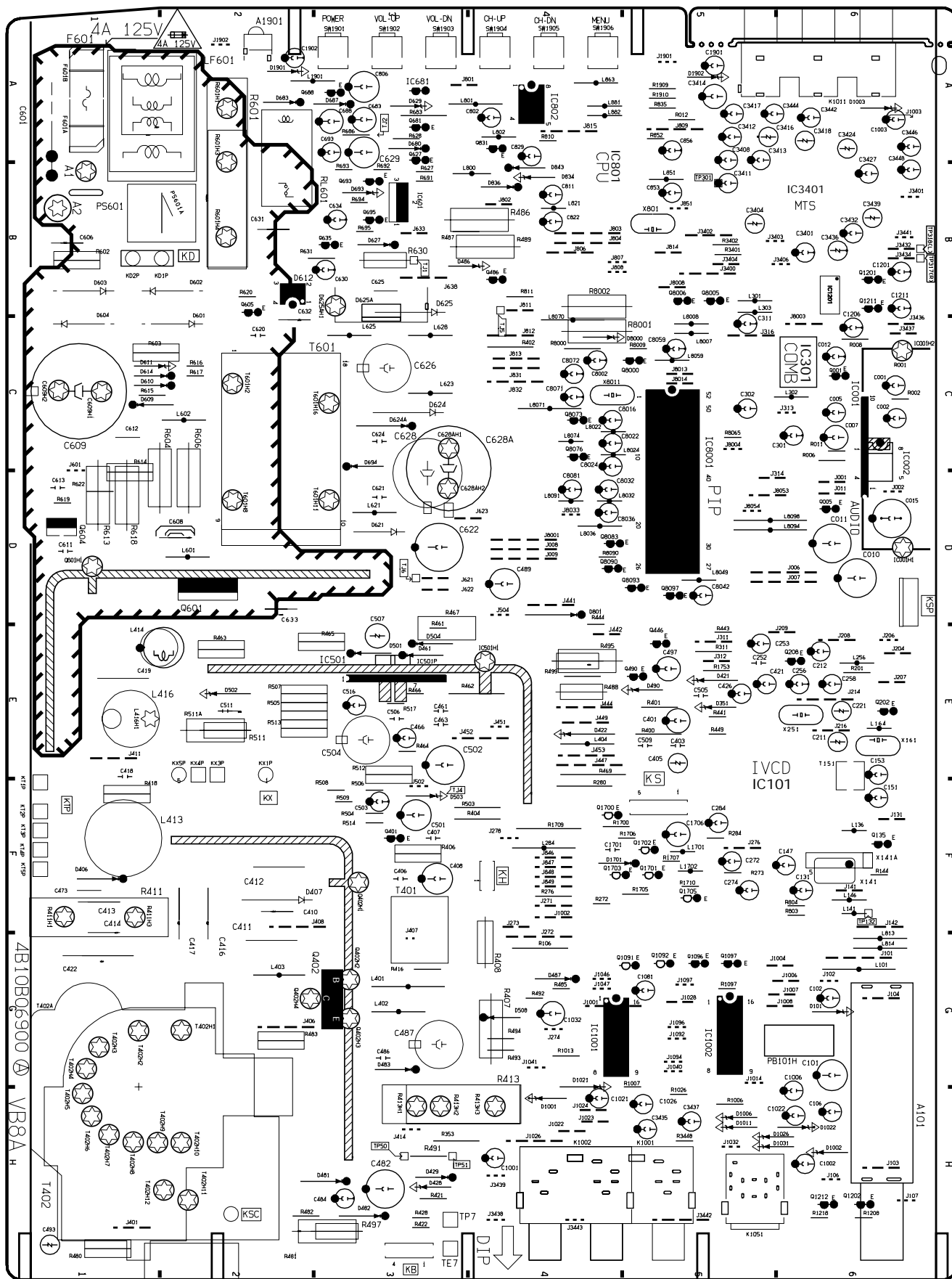

PICTURE TUBE SOCKET BOARD

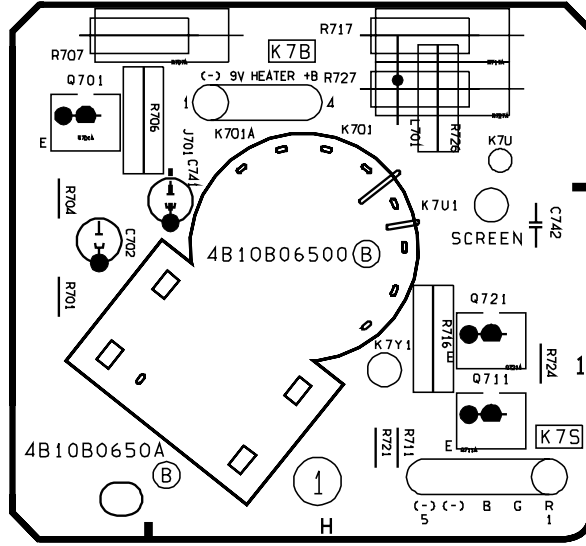

For parts or service contact

SANYO Fisher Service Corporation
21605 Plummer Street
Chatsworth, CA 91311 (U.S.A.)
300 Applewood Crescent,
Concord, Ontario L4K 5C7 (CANADA)

April / 2002 / 2000 SMC

Printed in U.S.A.

NOTE: Waveforms were taken with color-bar signal and the controls adjusted for normal picture.

SCHMATIC DIAGRAMS

NOTES ON SCHEMATIC DIAGRAMS
 1. All resistance values in ohms K=1,000 M=1,000,000.
 2. Unless otherwise noted on schematic, all capacitor values less than 1 are expressed in µF (Micro Farad), and the values more than 1 are in pF.
 3. Unless otherwise noted on schematic, voltage reading taken with VOM from point indicated to chassis ground. Voltage reading taken using color-bar signal VHF channel 5, all controls at normal. Line voltage at 120 volts. Some voltages may vary with signal strength.
 4. Waveforms were taken with color-bar signal and controls adjusted for normal picture. Waveforms marked with an * may vary with signal strength.
 5. The Symbol  indicates a fusible resistor, which protects the circuit from possible short circuits.

SERVICE NOTES:
 1. When replacing parts on circuit boards, clamp the lead wires to terminals before soldering.
 2. When replacing high wattage resistors on circuit board, keep the resistor body 10 mm (3/8") from circuit board.
 3. Keep wires away from high voltage and high temperature components.

PRODUCT SAFETY NOTICE
 THE COMPONENTS DESIGNATED BY A STAR (*) ON THIS SCHEMATIC DIAGRAM DESIGNATE COMPONENTS WHOSE VALUES ARE OF SPECIAL SIGNIFICANCE TO PRODUCT SAFETY. SHOULD ANY COMPONENT DESIGNATED BY A STAR NEED TO BE REPLACED, USE ONLY THE PART DESIGNATED IN THE PARTS LIST. DO NOT DEVIATE FROM THE RESISTANCE, WATTAGE AND VOLTAGE RATINGS SHOWN.

X-RADIATION WARNING NOTE
 THIS TV CONTAINS CRITICAL PARTS TO PROTECT AGAINST X-RADIATION. NOMINAL 2ND ANODE VOLTAGE IS 29.0KV AT ZERO BEAM CURRENT AT 120 VOLTS AC LINE, AND MUST NOT EXCEED 30.0KV UNDER ANY OPERATING CONDITION. SEE HIGH VOLTAGE CHECK ON PAGE 8.

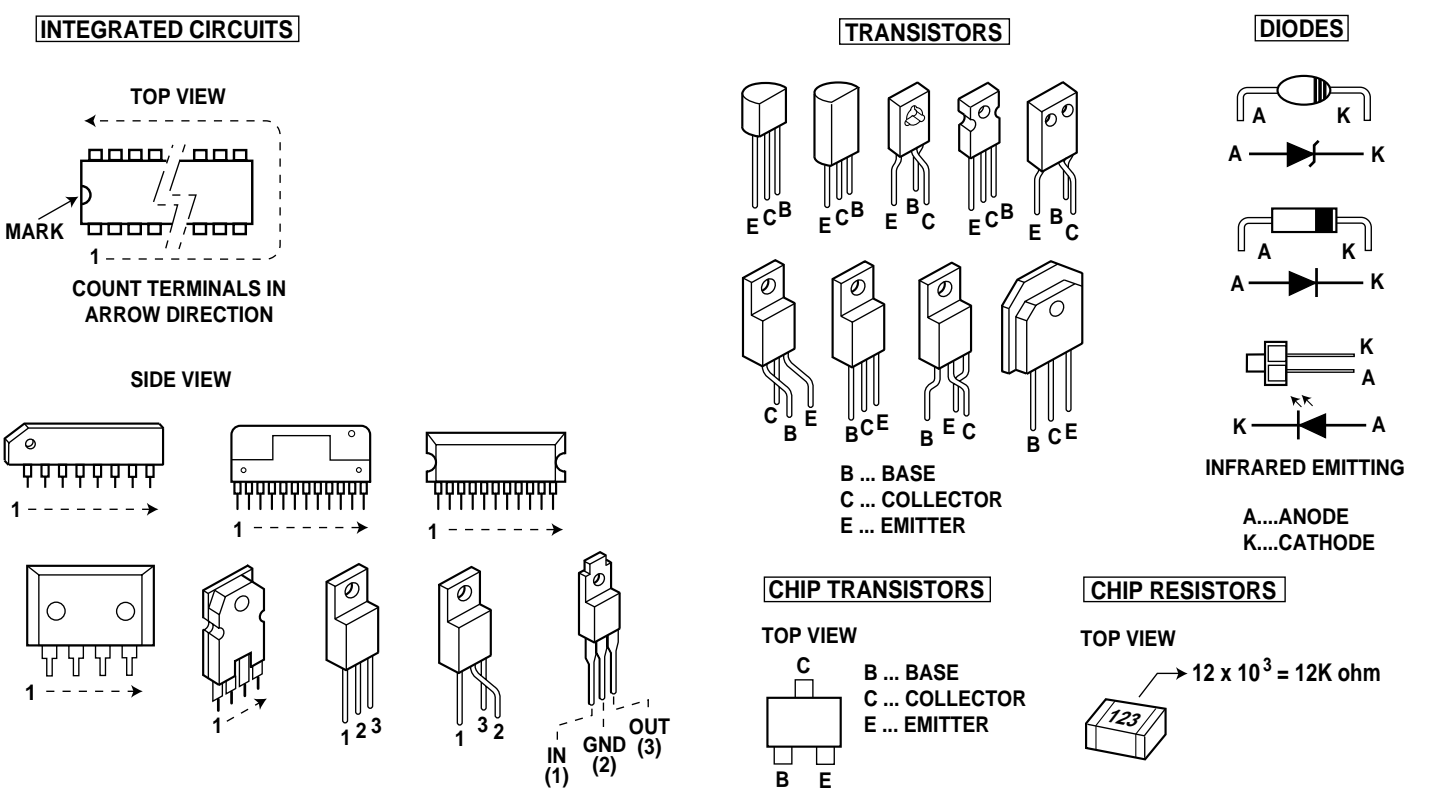

BLOCK DIAGRAM

CAUTION FOR CONTINUED PROTECTION AGAINST A RISK OF FIRE, REPLACE ONLY WITH THE SAME TYPE 4A, 125V FUSE.
 ATTENTION: POUR MAINTENIR LA PROTECTION CONTRE LES RISQUES D'INCENDIE UTILISER UN FUSIBLE DE REMPLACEMENT DE MEME TYPE 4A, 125V.

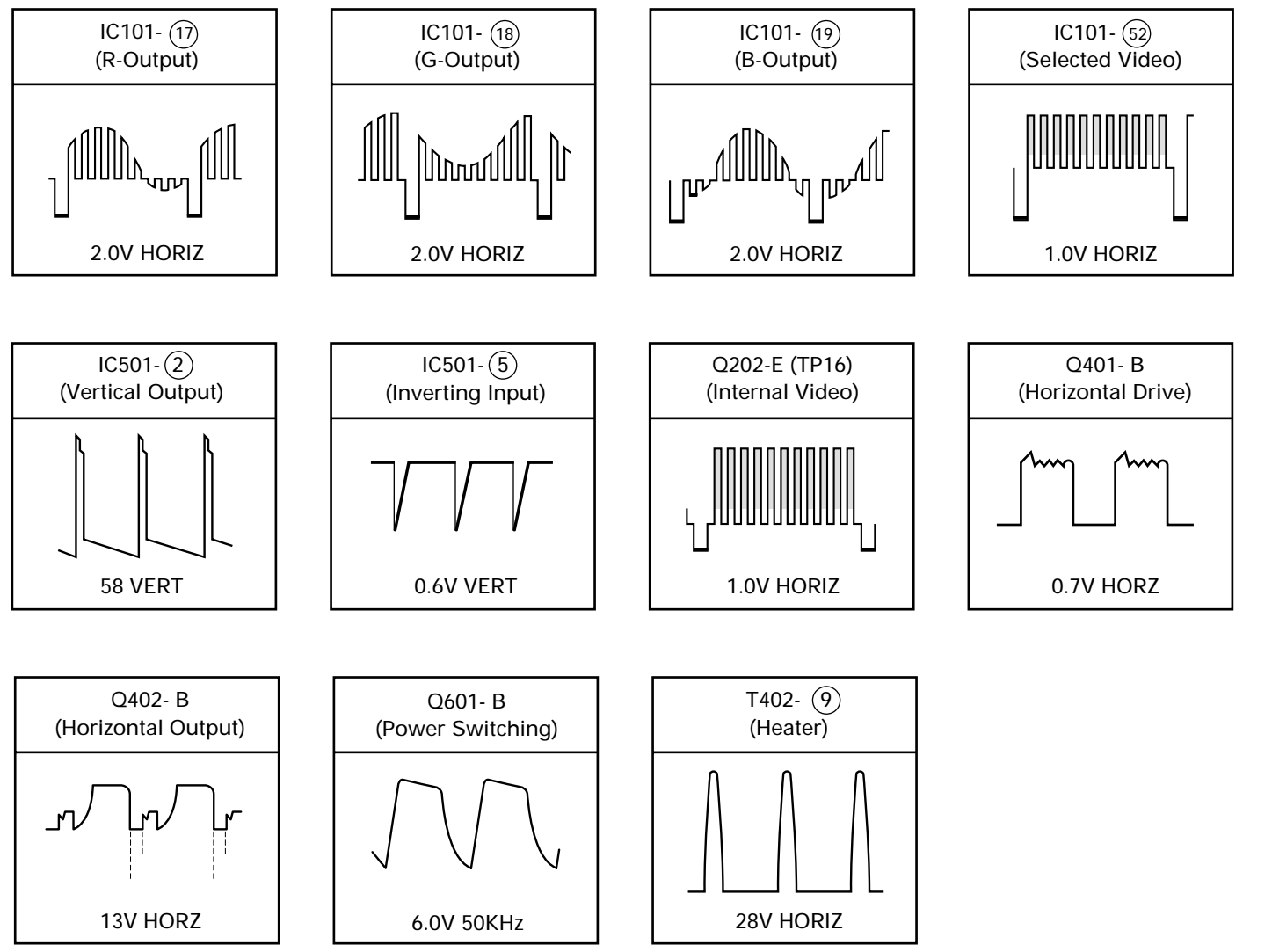
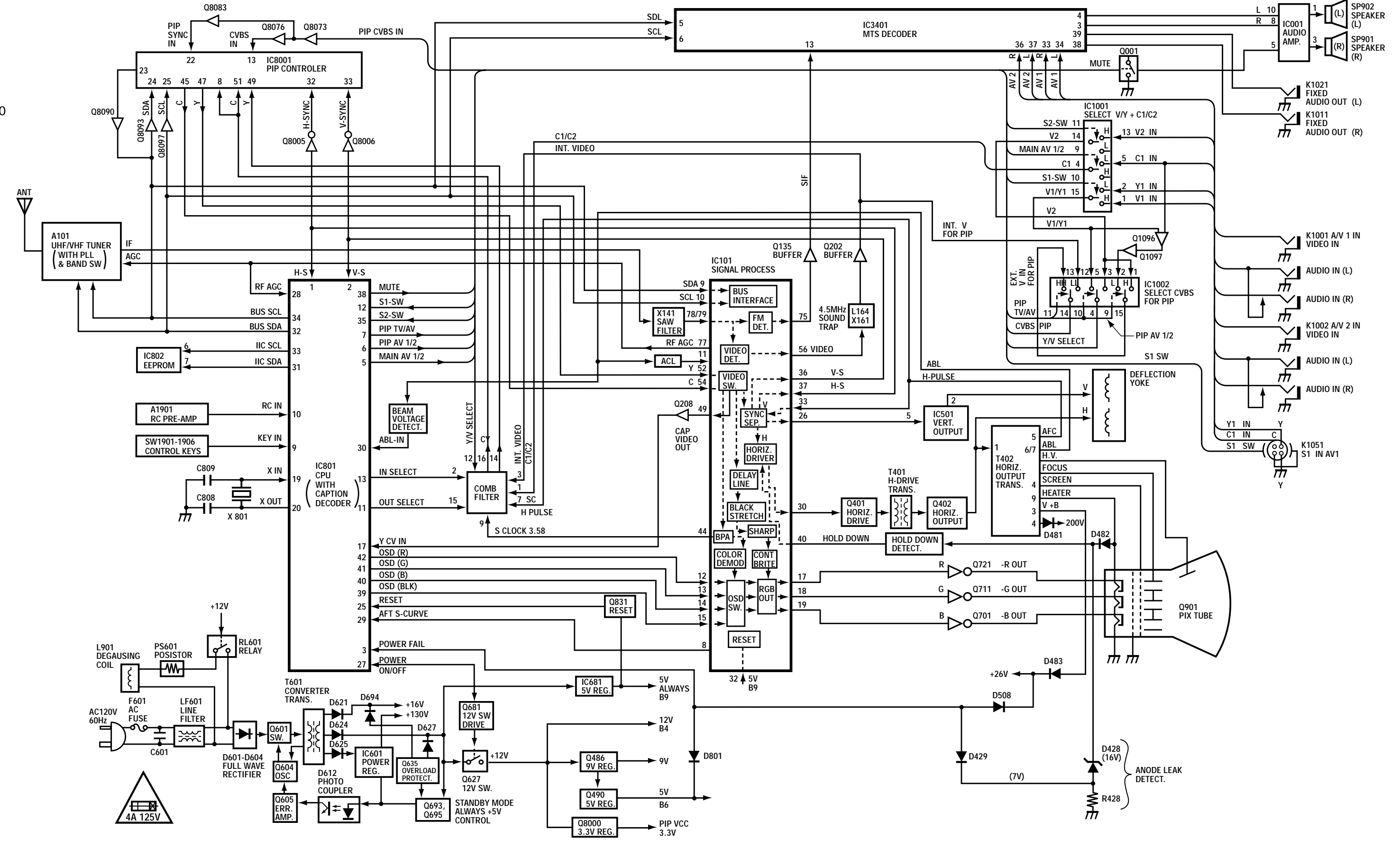

VOLTAGE CHARTS

NOTE: Voltages were measured using color-bar signal and the controls adjusted for normal picture.

CAPACITOR AND RESISTOR CODE CHART

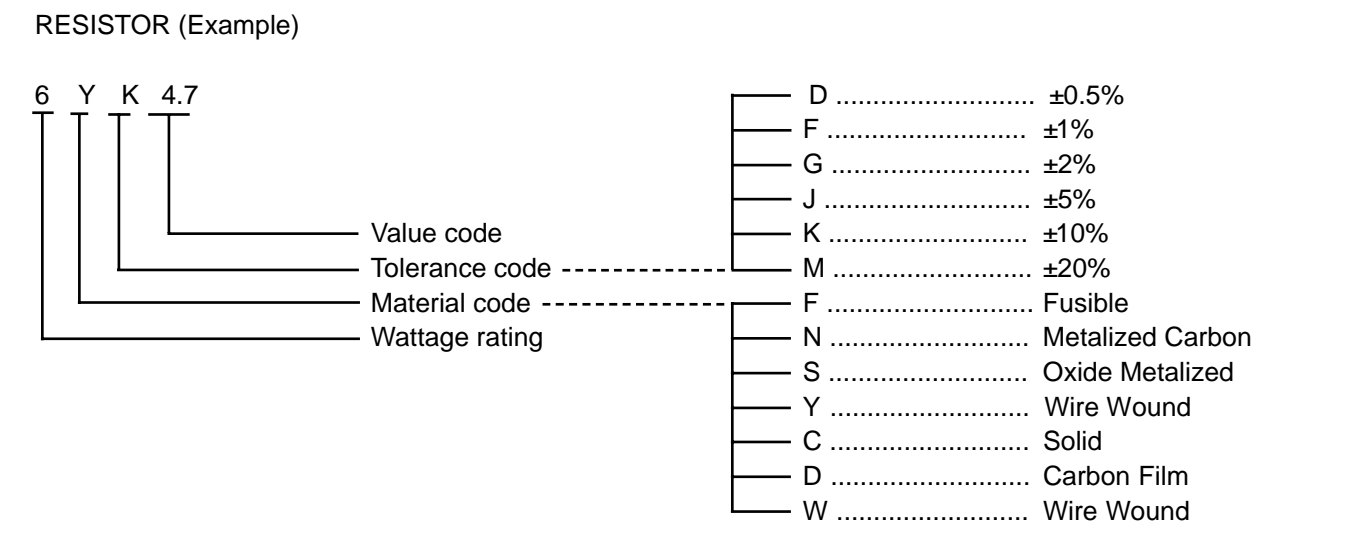
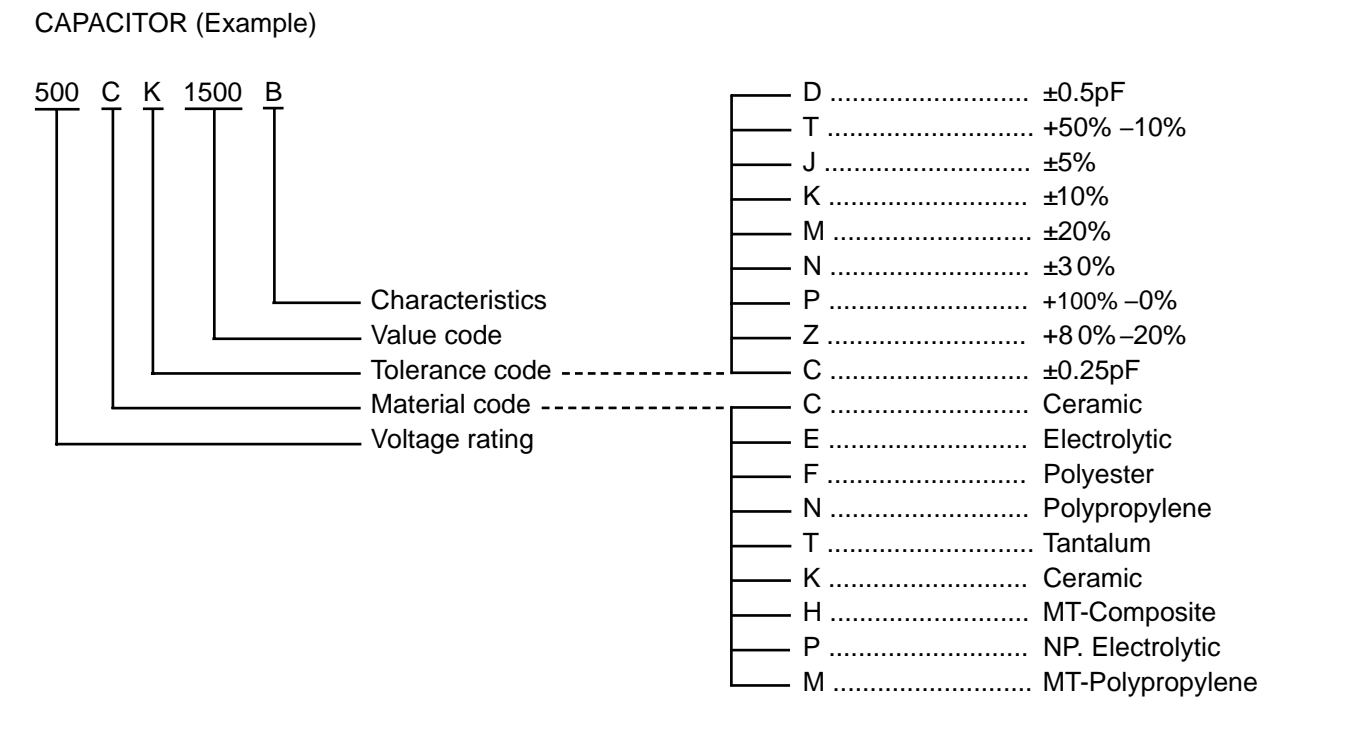

Device/Pin #	Volts/Mode	Device/Pin #	Volts/Mode	Device/Pin #	Volts/Mode	Device/Pin #	Volts/Mode	Device/Pin #	Volts/Mode
D612-1	POWER ON: 31.9 POWER OFF: 10.9	IC101-42	GND	IC501-5	2.9	IC3401-19	9.1	IC8001-29	0
D612-2	POWER ON: 31.0 POWER OFF: 9.8	IC101-43	GND	IC501-6	26.2	IC3401-20	0	IC8001-30	GND
D612-3	POWER ON: -3 POWER OFF: 0.6	IC101-44	2.2	IC501-7	3.0	IC3401-21	4.1	IC8001-31	N.C.
D612-4	POWER ON: 13.3 POWER OFF: 1.4	IC101-45	3.7	IC501-8	2.9	IC3401-22	4.1	IC8001-32	0.4
IC001-1	7.4	IC101-46	2.0	IC501-9	4.9	IC3401-23	3.7	IC8001-33	0.3
IC001-2	GND	IC101-47	3.0	IC501-10	13.3	IC3401-24	3.9	IC8001-34	3.1
IC001-3	7.7	IC101-48	0	IC601-1	POWER ON: 129.2 POWER OFF: 92.5	IC3401-25	4.1	IC8001-35	3.1
IC001-4	15.5	IC101-49	2.5	IC601-2	POWER ON: 31.1 POWER OFF: 9.8	IC3401-26	4.1	IC8001-36	GND
IC001-5	7.9	IC101-50	GND	IC601-3	GND	IC3401-27	4.1	IC8001-37	3.0
IC001-6	10.8	IC101-51	GND	IC601-4	POWER ON: 11.6 POWER OFF: 7.3	IC3401-28	1.9	IC8001-38	0.9
IC001-7	2.2	IC101-52	2.8	IC601-5	POWER ON: 5.0 POWER OFF: 5.0	IC3401-29	4.1	IC8001-39	2.9
IC001-8	1.4	IC101-53	5.2	IC601-6	POWER ON: 31.1 POWER OFF: 9.8	IC3401-30	4.1	IC8001-40	1.2
IC001-9	GND	IC101-54	2.7	IC601-7	GND	IC3401-31	2.0	IC8001-41	1.2
IC001-10	GND	IC101-55	2.7	IC601-8	GND	IC3401-32	4.1	IC8001-42	GND
IC101-1	GND	IC101-56	2.3	IC601-9	POWER ON: 5.0 POWER OFF: 5.0	IC3401-33	4.1	IC8001-43	0.9
IC101-2	GND	IC101-57	GND	IC601-10	GND	IC3401-34	4.1	IC8001-44	3.2
IC101-3	GND	IC101-58	3.6	IC601-11	0	IC3401-35	0	IC8001-45	0.9
IC101-4	GND	IC101-59	4.4	IC601-12	0	IC3401-36	4.1	IC8001-46	3.2
IC101-5	GND	IC101-60	4.4	IC601-13	4.0	IC3401-37	4.1	IC8001-47	1.0
IC101-6	GND	IC101-61	GND	IC601-14	4.9	IC3401-38	4.1	IC8001-48	GND
IC101-7	GND	IC101-62	GND	IC601-15	0	IC3401-39	4.1	IC8001-49	1.0
IC101-8	GND	IC101-63	GND	IC601-16	0	IC3401-40	4.1	IC8001-50	GND
IC101-9	GND	IC101-64	GND	IC601-17	0	IC3401-41	4.1	IC8001-51	0.9
IC101-10	GND	IC101-65	2.3	IC601-18	0.3	IC3401-42	9.3	IC8001-52	GND
IC101-11	GND	IC101-66	2.3	IC601-19	0	IC3401-43	4.1	O001-B	POWER ON: 0 POWER OFF: 0.7
IC101-12	GND	IC101-67	1.9	IC601-20	0	IC3401-44	4.1	O001-C	POWER ON: 7.7 POWER OFF: 0
IC101-13	GND	IC101-68	2.5	IC601-21	4.9	IC3401-45	4.2	O001-E	GND
IC101-14	GND	IC101-69	3.2	IC601-22	4.8	IC3401-46	GND	Q135-B	POWER ON: 2.3 POWER OFF: 6.2
IC101-15	0	IC101-70	GND	IC601-23	4.9	IC3401-47	4.1	Q135-C	POWER ON: 5.2 POWER OFF: 1.7
IC101-16	8.3	IC101-71	GND	IC601-24	4.9	IC3401-48	4.1	Q202-B	2.7
IC101-17	2.5	IC101-72	GND	IC601-25	0.2	IC8001-1	GRD	Q202-C	GND
IC101-18	2.5	IC101-73	2.3	IC601-26	0.2	IC8001-2	2.1	Q202-E	3.4
IC101-19	2.5	IC101-74	0	IC601-27	POWER ON: 4.9 POWER OFF: 0	IC8001-3	1.6	IC8001-4	1.8
IC101-20	2.25	IC101-75	2.3	IC601-28	0	IC8001-4	1.8	IC8001-5	1.6
IC101-21	GND	IC101-76	2.7	IC601-29	2.2	IC8001-5	1.6	IC8001-6	3.2
IC101-22	GND	IC101-77	2.3	IC601-30	2.0	IC8001-6	3.2	IC8001-7	3.2
IC101-23	GND	IC101-78	2.9	IC601-31	4.9	IC8001-7	3.2	IC8001-8	0.9
IC101-24	GND	IC101-79	2.9	IC601-32	4.9	IC8001-8	0.9	IC8001-9	1.4
IC101-25	2.0	IC101-80	GND	IC601-33	3.6	IC8001-9	1.4	IC8001-10	3.2
IC101-26	2.4	IC301-1	0.9	IC601-34	4.8	IC8001-10	0.5	IC8001-11	GND
IC101-27	2.6	IC301-2	4.8	IC601-35	4.9	IC8001-11	GND	IC8001-12	3.2
IC101-28	5.3	IC301-3	2.0	IC601-36	4.9	IC8001-12	3.2	IC8001-13	4.1
IC101-29	2.8	IC301-4	2.0	IC601-37	4.9	IC8001-13	4.1	IC8001-14	1.4
IC101-30	0.6	IC301-5	5.1	IC601-38	4.9	IC8001-14	1.4	IC8001-15	0.5
IC101-31	GND	IC301-6	5.1	IC601-39	0	IC8001-15	0.5	IC8001-16	GRD
IC101-32	4.9	IC301-7	0.3	IC601-40	4.9	IC8001-16	GRD	IC8001-17	3.1
IC101-33	1.0	IC301-8	-0.3	IC601-41	4.9	IC8001-17	3.1	IC8001-18	GRD
IC101-34	1.8	IC301-9	0.6	IC601-42	0	IC8001-18	GRD	IC8001-19	3.1
IC101-35	4.8	IC301-10	0	IC801-1	0	IC8001-19	3.1	IC8001-20	N.C.
IC101-36	3.9	IC301-11	0	IC801-2	4.9	IC8001-20	N.C.	IC8001-21	0
IC101-37	4.0	IC301-12	1.5	IC801-3	3.7	IC8001-21	0	IC8001-22	4.9
IC101-38	4.7	IC301-13	GND	IC801-4	4.8	IC8001-22	4.9	IC8001-23	0.1
IC101-39	GND	IC301-14	1.9	IC801-5	4.9	IC8001-23	0.1	IC8001-24	0.3
IC101-40	GND	IC301-15	0	IC801-6	4.9	IC8001-24	0.3	IC8001-25	2.2
		IC301-16	1.5	IC801-7	4.9	IC8001-25	2.2	IC8001-26	GND
		IC501-1	GND	IC801-8	4.9	IC8001-26	GND	IC8001-27	3.1
		IC501-2	13.7	IC801-9	0	IC8001-27	3.1	IC8001-28	N.C.
		IC501-3	27.1	IC801-10	0	IC8001-28	N.C.		
		IC501-4	2.9	IC801-11	0				

Device/Pin #	Volts/Mode	Device/Pin #	Volts/Mode	Device/Pin #	Volts/Mode	Device/Pin #	Volts/Mode
Q604-B	POWER ON: 13.1 POWER OFF: 1.4	O8000-B	3.9	Q604-C	POWER ON: -0.4 POWER OFF: 0.6	O8000-C	4.2
Q604-E	POWER ON: -0.3 POWER OFF: 0	O8000-E	3.2	Q605-B	POWER ON: 11.1 POWER OFF: 7.3	O8005-B	0.6
Q605-C	POWER ON: 13.0 POWER OFF: 2.0	O8005-C	0.3	Q605-D	POWER ON: 11.6 POWER OFF: 1.0	O8005-D	GND
Q605-E	POWER ON: 11.9 POWER OFF: 7.3	O8005-E	GND	Q606-B	POWER ON: 11.1 POWER OFF: 7.3	O8005-F	3.7
Q635-B	POWER ON: 4.2 POWER OFF: 1.4	O8006-B	0.6	Q635-C	POWER ON: 4.2 POWER OFF: 1.4	O8006-C	0.2
Q635-E	POWER ON: 4.2 POWER OFF: 1.4	O8006-E	GND	Q635-F	POWER ON: 4.2 POWER OFF: 1.4	O8006-F	4.3
Q681-B	POWER ON: 0.7 POWER OFF: 0	O8007-B	9.0	Q681-C	POWER ON: 0.7 POWER OFF: 0	O8007-C	3.1
Q681-C	POWER ON: 0.7 POWER OFF: 0	O8007-D	0	Q681-D	POWER ON: 0.7 POWER OFF: 0	O8007-E	0
Q681-E	POWER ON: 0.7 POWER OFF: 0	O8007-F	3.7	Q681-F	POWER ON: 0.7 POWER OFF: 0	O8007-G	0
Q681-F	POWER ON: 0.7 POWER OFF: 0	O8007-H	4.4	Q681-G	POWER ON: 0.7 POWER OFF: 0	O8007-I	2.9
Q693-B	POWER ON: 0.5 POWER OFF: 6.2	O8007-J	2.9	Q693-C	POWER ON: 0.5 POWER OFF: 6.2	O8007-K	0.2
Q693-C	POWER ON: 30.9 POWER OFF: 8.9	O8007-L	3.1	Q693-D	POWER ON: 30.9 POWER OFF: 8.9	O8007-M	3.1
Q693-E	POWER ON: 30.9 POWER OFF: 9.6	O8007-N	0	Q693-F	POWER ON: 30.9 POWER OFF: 9.6	O8007-O	0
Q695-B	POWER ON: 30.9 POWER OFF: 9.6	O8007-P	0	Q695-C	POWER ON: 30.9 POWER OFF: 9.6	O8007-Q	0
Q695-C	GND	O8007-R	0	Q695-D	POWER ON: 30.9 POWER OFF: 9.6	O8007-S	0
Q695-E	POWER ON: 31.0 POWER OFF: 9.8	O8007-T	0	Q695-F	POWER ON: 31.0 POWER OFF: 9.8	O8007-U	0
Q701-B	2.6	O8007-V	0	Q701-C	POWER ON: 2.6 POWER OFF: 2.6	O8007-W	0
Q701-C	141.9	O8007-X	0	Q701-D	POWER ON: 2.6 POWER OFF: 2.6	O8007-Y	0
Q701-E	2.5	O8007-Z	0	Q701-F	POWER ON: 2.6 POWER OFF: 2.6	O8008-A	0
Q711-B	2.6	O8008-A	0	Q711-C	POWER ON: 2.6 POWER OFF: 2.6	O8008-B	0
Q711-E	143.1	O8008-C	0	Q711-D	POWER ON: 2.6 POWER OFF: 2.6	O8008-D	0
Q711-F	2.5	O8008-E	0	Q711-E	POWER ON: 2.6 POWER OFF: 2.6	O8008-F	0
Q721-B	2.6	O8008-G	0	Q721-C	POWER ON: 2.6 POWER OFF: 2.6	O8008-H	0
Q721-C	146.1	O8008-I	0	Q721-D	POWER ON: 2.6 POWER OFF: 2.6	O8008-J	0
Q721-E	2.5	O8008-K	0	Q721-E	POWER ON: 2.6 POWER OFF: 2.6	O8008-L	0
Q831-B	4.9	O8008-M	0	Q831-C	POWER ON: 4.9 POWER OFF: 4.9	O8008-N	0
Q831-C	4.9	O8008-O	0	Q831-D	POWER ON: 4.9 POWER OFF: 4.9	O8008-P	0
Q831-E	4.9	O8008-Q	0	Q831-E	POWER ON: 4.9 POWER OFF: 4.9	O8008-R	0
O1096-B	6.9	O8008-S	0	Q831-F	POWER ON: 4.9 POWER OFF: 4.9	O1096-C	9.1
O1096-C	9.1	O8008-T	0	Q831-G	POWER ON: 4.9 POWER OFF: 4.9	O1096-D	6.2
O1096-E	6.2	O8008-U	0	Q831-H	POWER ON: 4.9 POWER OFF: 4.9	O1096-F	5.9
O1097-B	5.9	O8008-V	0	Q831-I	POWER ON: 4.9 POWER OFF: 4.9	O1097-C	9.1
O1097-C	9.1	O8008-W	0	Q831-J	POWER ON: 4.9 POWER OFF: 4.9	O1097-D	9.1
O1097-E	5.3	O8008-X	0	Q831-K	POWER ON: 4.9 POWER OFF: 4.9	O1097-E	5.3

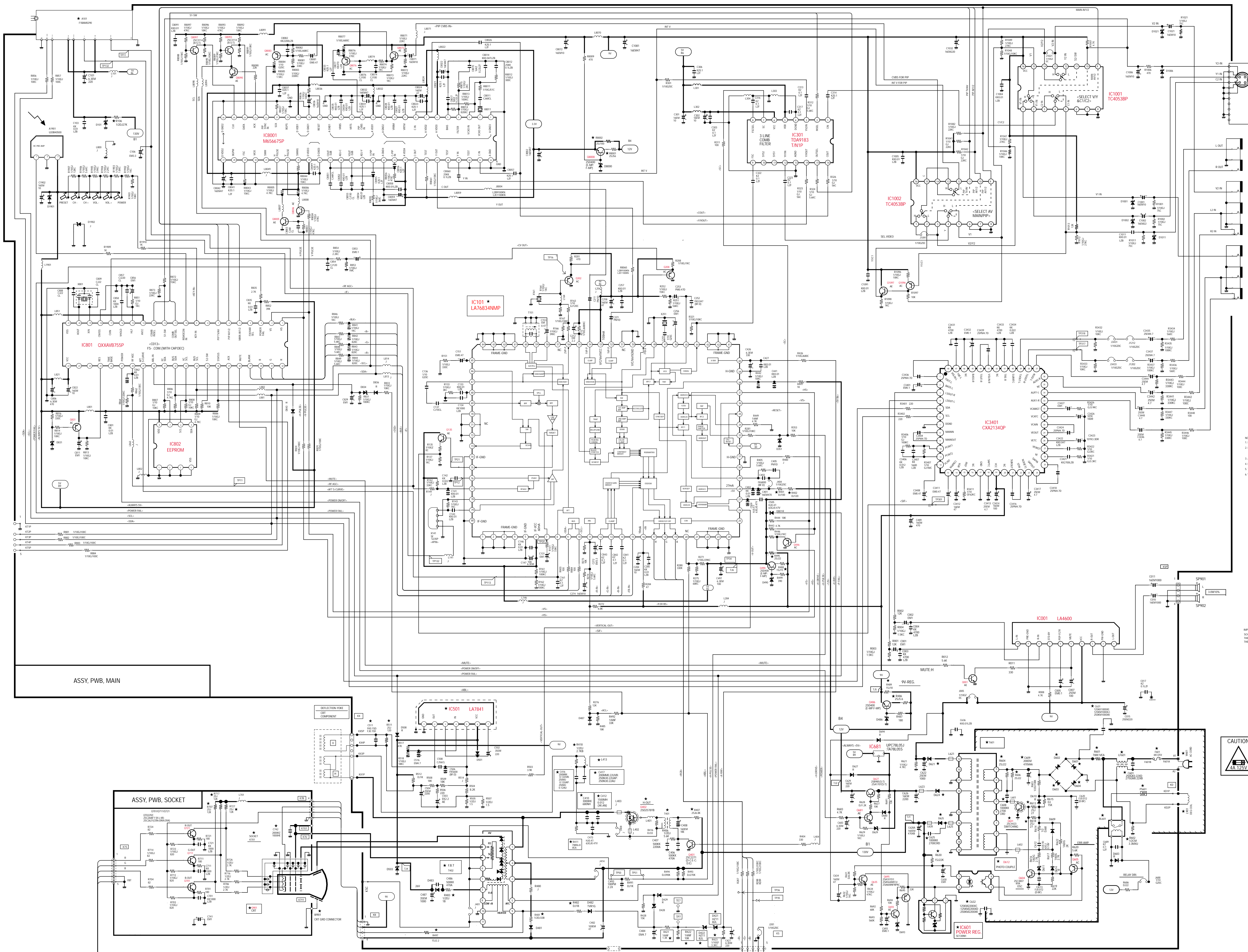

NOTES:

- RESISTORS SPECIFIED WITH RESISTANCE VALUE ARE 1% TOL.
- RESISTORS SPECIFIED WITH TYPE OF RESISTOR, TOLERANCE AND RESISTANCE VALUE ARE 1% TOL.
- ALL CAPACITORS ARE 50V UNLESS OTHERWISE NOTED.
- PARTS SHOWN WITH A WAVEFORM SYMBOL ARE RELATED WITH A WAVEFORM.
- TRAIL LINES ARE TERMINAL SHIELDING.
- VIEW OF TR & T.C.

7. ISOLATION BORDER LINE

8. LIST OF REPLACEABLE ENDS:

END NO.	DESCRIPTION	QTY	UNIT	REVISION
1	RESISTOR	1	PCB	1.0
2	RESISTOR	1	PCB	1.0
3	RESISTOR	1	PCB	1.0
4	RESISTOR	1	PCB	1.0
5	RESISTOR	1	PCB	1.0
6	RESISTOR	1	PCB	1.0
7	RESISTOR	1	PCB	1.0
8	RESISTOR	1	PCB	1.0
9	RESISTOR	1	PCB	1.0
10	RESISTOR	1	PCB	1.0
11	RESISTOR	1	PCB	1.0
12	RESISTOR	1	PCB	1.0
13	RESISTOR	1	PCB	1.0
14	RESISTOR	1	PCB	1.0
15	RESISTOR	1	PCB	1.0
16	RESISTOR	1	PCB	1.0
17	RESISTOR	1	PCB	1.0
18	RESISTOR	1	PCB	1.0
19	RESISTOR	1	PCB	1.0
20	RESISTOR	1	PCB	1.0
21	RESISTOR	1	PCB	1.0
22	RESISTOR	1	PCB	1.0
23	RESISTOR	1	PCB	1.0
24	RESISTOR	1	PCB	1.0
25	RESISTOR	1	PCB	1.0
26	RESISTOR	1	PCB	1.0
27	RESISTOR	1	PCB	1.0
28	RESISTOR	1	PCB	1.0
29	RESISTOR	1	PCB	1.0
30	RESISTOR	1	PCB	1.0
31	RESISTOR	1	PCB	1.0
32	RESISTOR	1	PCB	1.0
33	RESISTOR	1	PCB	1.0
34	RESISTOR	1	PCB	1.0
35	RESISTOR	1	PCB	1.0
36	RESISTOR	1	PCB	1.0
37	RESISTOR	1	PCB	1.0
38	RESISTOR	1	PCB	1.0
39	RESISTOR	1	PCB	1.0
40	RESISTOR	1	PCB	1.0
41	RESISTOR	1	PCB	1.0
42	RESISTOR	1	PCB	1.0
43	RESISTOR	1	PCB	1.0
44	RESISTOR	1	PCB	1.0
45	RESISTOR	1	PCB	1.0
46	RESISTOR	1	PCB	1.0
47	RESISTOR	1	PCB	1.0
48	RESISTOR	1	PCB	1.0
49	RESISTOR	1	PCB	1.0
50	RESISTOR	1	PCB	1.0
51	RESISTOR	1	PCB	1.0
52	RESISTOR	1	PCB	1.0
53	RESISTOR	1	PCB	1.0
54	RESISTOR	1	PCB	1.0
55	RESISTOR	1	PCB	1.0
56	RESISTOR	1	PCB	1.0
57	RESISTOR	1	PCB	1.0
58	RESISTOR	1	PCB	1.0
59	RESISTOR	1	PCB	1.0
60	RESISTOR	1	PCB	1.0
61	RESISTOR	1	PCB	1.0
62	RESISTOR	1	PCB	1.0
63	RESISTOR	1	PCB	1.0
64	RESISTOR	1	PCB	1.0
65	RESISTOR	1	PCB	1.0
66	RESISTOR	1	PCB	1.0
67	RESISTOR	1	PCB	1.0
68	RESISTOR	1	PCB	1.0
69	RESISTOR	1	PCB	1.0
70	RESISTOR	1	PCB	1.0
71	RESISTOR	1	PCB	1.0
72	RESISTOR	1	PCB	1.0
73	RESISTOR	1	PCB	1.0
74	RESISTOR	1	PCB	1.0
75	RESISTOR	1	PCB	1.0
76	RESISTOR	1	PCB	1.0
77	RESISTOR	1	PCB	1.0
78	RESISTOR	1	PCB	1.0
79	RESISTOR	1	PCB	1.0
80	RESISTOR	1	PCB	1.0
81	RESISTOR	1	PCB	1.0
82	RESISTOR	1	PCB	1.0
83	RESISTOR	1	PCB	1.0
84	RESISTOR	1	PCB	1.0
85	RESISTOR	1	PCB	1.0
86	RESISTOR	1	PCB	1.0
87	RESISTOR	1	PCB	1.0
88	RESISTOR	1	PCB	1.0
89	RESISTOR	1	PCB	1.0
90	RESISTOR	1	PCB	1.0
91	RESISTOR	1	PCB	1.0
92	RESISTOR	1	PCB	1.0
93	RESISTOR	1	PCB	1.0
94	RESISTOR	1	PCB	1.0
95	RESISTOR	1	PCB	1.0
96	RESISTOR	1	PCB	1.0
97	RESISTOR	1	PCB	1.0
98	RESISTOR	1	PCB	1.0
99	RESISTOR	1	PCB	1.0
100	RESISTOR	1	PCB	1.0

9. VIEW OF TR & T.C.

10. 17" JUMPER WIRE

11. PART NOT USED

12. 17" JUMPER WIRE

13. PART NOT USED

CAUTION FOR CONTINUED PROTECTION AGAINST A RISK OF FIRE, REPLACE ONLY WITH THE SAME TYPE 4A, 125V FUSE. ATTENTION: POUR MAINTENIR LA PROTECTION CONTRE LES RISQUES D'INCENDIE UTILISER UN FUSIBLE DE RECHANGE DE MEME TYPE 4A, 125V.