

## DS50PCI401

# 2.5 Gbps / 5.0 Gbps 4 Lane PCI Express Transceiver with Equalization and De-Emphasis

### General Description

The DS50PCI401 is a low power, 4 lane bidirectional buffer/equalizer designed specifically for PCI Express Gen1 and Gen2 applications. The device performs both receive equalization and transmit de-emphasis, allowing maximum flexibility of physical placement within a system. The receiver is capable of opening an input eye that is completely closed due to inter-symbol interference (ISI) induced by the interconnect medium.

The transmitter de-emphasis level can be set by the user depending on the distance from the DS50PCI401 to the PCI Express endpoint. The DS50PCI401 contains PCI Express specific functions such as Transmit Idle, RX Detection, and Beacon signal pass through.

The device will change the load impedance on its input pins based on the state of RXDETA/B inputs detection. An internal rate detection circuit is included to detect if an incoming data stream is at Gen2 data rates, and adjusts the de-emphasis on it's output accordingly. The signal conditioning provided by the device allows systems to upgrade from Gen1 data rates to Gen2 without reducing their physical reach. This is true for FR4 applications such as backplanes, as well as cable interconnect.

### Features

- Input and Output signal conditioning increases PCIe reach in backplanes and cables
- 0.09 UI of residual deterministic jitter at 5Gbps after 42" of FR4 (with Input EQ)
- 0.11 UI of residual deterministic jitter at 5Gbps after 7m of PCIe Cable (with Input EQ)
- 0.09 UI of residual deterministic jitter at 5Gbps with 28" of FR4 (with Output DE)
- 0.13 UI of residual deterministic jitter at 5Gbps with 7m of PCIe Cable (with Output DE)
- Adjustable Transmit VOD 800 to 1200mVp-p
- Automatic power management on an individual lane basis via SMBus
- Adjustable electrical idle detect threshold.
- Data rate optimized 3-stage equalization to 26 dB gain
- Data rate optimized 6-level 0 to 12 dB transmit de-emphasis
- Flow-thru pinout in 10mmx5.5mm 54-pin leadless LLP package
- Single supply operation at 2.5V
- >6kV HBM ESD rating
- -10 to 85°C operating temperature range

### Typical Application

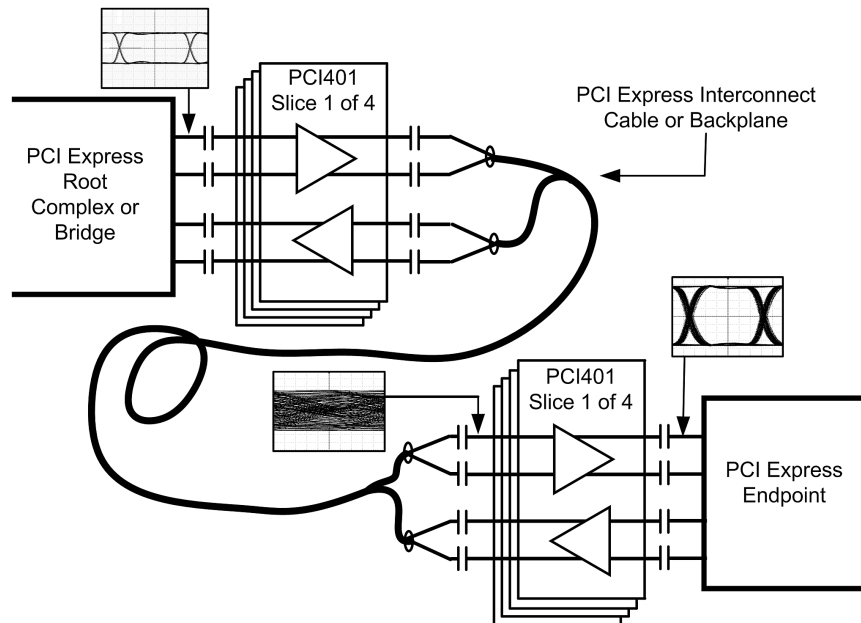

30060480

# Block Diagram - Detail View Of Channel (1 Of 8)

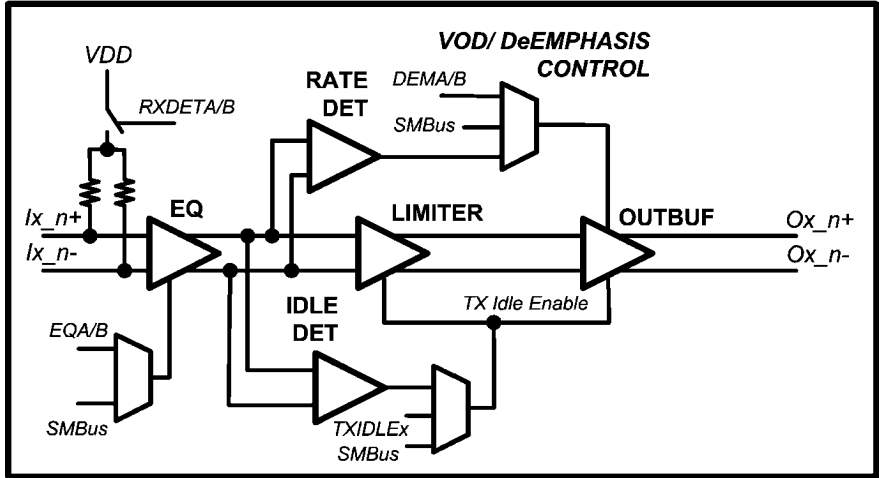

30060486

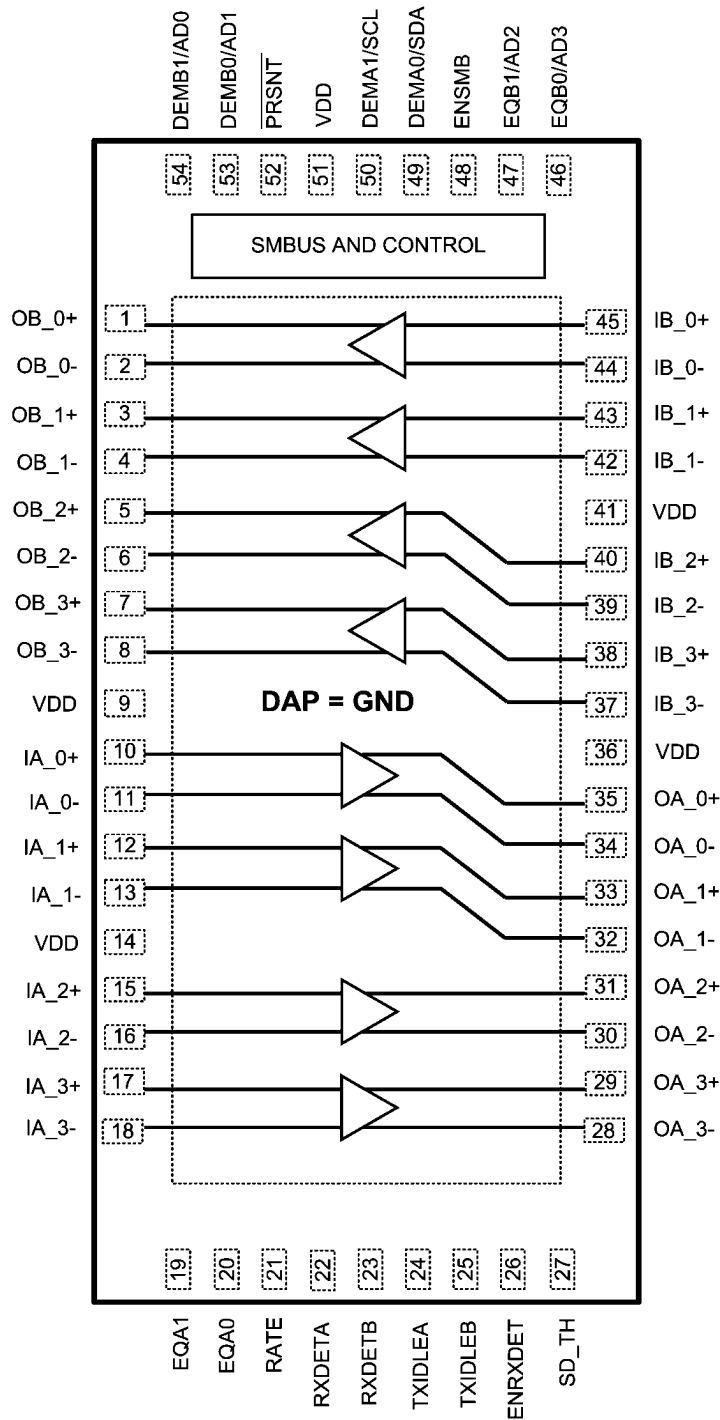

DS50PCI401 Pin Diagram 54 lead

30060492

## Ordering Information

NSID	Qty	Spec	Package
DS50PCI401SQ	Tape & Reel Supplied As 2,000 Units	NOPB	SQA54A
DS50PCI401SQE	Tape & Reel Supplied As 250 Units	NOPB	SQA54A

## Pin Descriptions

Pin Name	Pin Number	I/O, Type	Pin Description
<b>Differential High Speed I/O's</b>			
IA_0+, IA_0-, IA_1+, IA_1-, IA_2+, IA_2-, IA_3+, IA_3-	10, 11 12, 13 15, 16 17, 18	I, CML	Inverting and non-inverting CML differential inputs to the equalizer. A gated on-chip 50Ω termination resistor connects INA_0+ to VDD and INA_0- to VDD when enabled.
OA_0+, OA_0-, OA_1+, OA_1-, OA_2+, OA_2-, OA_3+, OA_3-	35, 34 33, 32 31, 30 29, 28	O, LPDS	Inverting and non-inverting low power differential signal (LPDS) 50Ω driver outputs with de-emphasis. Compatible with AC coupled CML inputs.
IB_0+, IB_0-, IB_1+, IB_1-, IB_2+, IB_2-, IB_3+, IB_3-	45, 44 43, 42 40, 39 38, 37	I, CML	Inverting and non-inverting CML differential inputs to the equalizer. A gated on-chip 50Ω termination resistor connects INB_0+ to VDD and INB_0- to VDD when enabled.
OB_0+, OB_0-, OB_1+, OB_1-, OB_2+, OB_2-, OB_3+, OB_3-	1, 2 3, 4 5, 6 7, 8	O, LPDS	Inverting and non-inverting low power differential signal (LPDS) 50Ω driver outputs with de-emphasis. Compatible with AC coupled CML inputs.
<b>Control Pins — Shared (LVCMOS)</b>			
ENSMB	48	I, LVCMOS w/ internal pulldown	System Management Bus (SMBus) enable pin. When pulled high provide access internal digital registers that are a means of auxiliary control for such functions as equalization, de-emphasis, VOD, rate, and idle detection threshold. When pulled low, access to the SMBus registers are disabled and SMBus function pins are used to control the Equalizer and De-Emphasis. Please refer to “SMBus configuration Registers” section and Electrical Characteristics - Serial Management Bus Interface for detail information.
<b>ENSMB = 1 (SMBUS MODE)</b>			
SCL	50	I, LVCMOS	ENSMB = 1 SMBUS clock input pin is enabled.
SDA,	49	I, LVCMOS, O, OPEN Drain	ENSMB = 1 The SMBus bi-directional SDA pin is enabled. Data input or open drain (pulldown only) output.
AD0-AD3	54, 53, 47, 46	I, LVCMOS w/ internal pulldown	ENSMB = 1 SMBus Slave Address Inputs. In SMBus mode, these pins are the user set SMBus slave address inputs.
<b>ENSMB = 0 (NORMAL PIN MODE)</b>			
EQA0, EQA1 EQB0, EQB1	20, 19 46, 47	I, FLOAT, LVCMOS	EQA/B ,0/1 controls the level of equalization of the A/B sides as shown in <i>Table 1</i> . The EQA/B pins are active only when ENSMB is de-asserted (Low). Each of the 4 A/B channels have the same level unless controlled by the SMBus control registers. When ENSMB goes high the SMBus registers provide independent control of each lane, and the EQB0/B1 pins are converted to SMBUS AD2/AD3 inputs.

Pin Name	Pin Number	I/O, Type	Pin Description
DEMA0, DEMA1 DEMB0, DEMB1	49, 50 53, 54	I, FLOAT, LVCMOS	DEMA/B ,0/1 controls the level of de-emphasis of the A/B sides as shown in <i>Table 2</i> . The DEMA/B pins are only active when ENSMB is de-asserted (Low). Each of the 4 A/B channels have the same level unless controlled by the SMBus control registers. When ENSMB goes High the SMBus registers provide independent control of each lane and the DEM pins are converted to SMBUS AD0/AD1 and SCL/SDA inputs.
RATE	21	I, FLOAT, LVCMOS	RATE control pin controls the pulse width of de-emphasis of the output. A Low forces Gen1 (2.5Gbps), High forces Gen 2 (5Gbps), Open/Floating the rate is internally detected after each exit from idle and the pulse width is set appropriately. When ENSMBUS= 1 this pin is disabled and the RATE function is controlled internally by the SMBUS registers. Refer to <i>Table 2</i> .
<b>Control Pins — Both Modes (LVCMOS)</b>			
RXDETA,RXDETB	22,23	I, LVCMOS w/ internal pulldown	The RXDET pins in combination with the ENRXDET pin controls the receiver detect function. Depending on the input level, a 50Ω or >50KΩ termination to the power rail is enabled. Refer to <i>Table 5</i> .
PRSN $\bar{T}$	52	I, LVCMOS	Cable Present Detect input. High when a cable is not present per PCIe Cabling Spec. 1.0. Puts part into low power mode. When low (normal operation) part is enabled.
ENRXDET	26	I, LVCMOS w/ internal pulldown	Enables pin control of receiver detect function. Pin must be pulled high externally for RXDETA/B to function. Controls both A and B sides. Refer to <i>Table 5</i> .
TXIDLEA,TXIDLEB	24,25	I, FLOAT, LVCMOS	Controls the electrical idle function on corresponding outputs when enabled. H= electrical Idle, Float=autodetect (Idle on input passed to output), L=Idle squelch disabled as shown in <i>Table 3</i> .
<b>Analog</b>			
SD_TH	27	I, ANALOG	Threshold select pin for electrical idle detect threshold. Float pin for default 130mV DIFF p-p, otherwise connect resistor from SD_TH to GND to set threshold voltage as shown in <i>Table 4</i> .
<b>Power</b>			
VDD	9, 14,36, 41, 51	Power	Power supply pins CML/analog.
GND	DAP	Power	Ground pad (DAP - die attach pad).
Notes:			
FLOAT = 3rd input state, don't drive pin. Pin is internally biased to mid level with 50 kΩ pull-up/pull-down. If high Z output not available, drive input to VDD/2 to assert mid level state.			
Internal pulldown = Internal 30 kΩ pull-down resistor to GND is present on the input.			
LVCMOS inputs without the "Float" conditions must be driven to a logic Low or High at all times or operation is not guaranteed.			
Input edge rate for LVCMOS/FLOAT inputs must be faster than 50 ns from 10–90%.			

## Functional Description

The DS50PCI401 is a low power media compensation 4 lane transceiver optimized for PCI Express Gen 1 and Gen 2 media including lossy FR-4 printed circuit board backplanes and balanced cables. The DS50PCI401 operates in two modes: Pin Control Mode (ENSMB = 0) and SMBus Mode (ENSMB = 1).

Pin Control Mode:

When in pin mode (ENSMB = 0), the transceiver is configurable with external pins. Equalization and de-emphasis can be selected via pin for each side independently. When de-emphasis is asserted VOD is automatically increased per the De-Emphasis table below for improved performance over lossy media. The receiver detect pins RXDETA/B provide manual control for input termination (50Ω or >50KΩ). Rate optimization is also pin controllable, with pin selections for 2.5Gbps, 5Gbps, and auto detect. The receiver electrical idle detect threshold is also programmable via an optional external resistor on the SD\_TH pin.

**SMBUS Mode:**

When in SMBus mode the equalization, de-emphasis, and termination disable features are all programmable on a individual lane basis, instead of grouped by sides as in the pin mode case. Upon assertion of ENSMB the RATE, EQx and DEMx functions revert to register control immediately. The EQx and DEMx pins are converted to AD0-AD3 SMBus ad-

dress inputs. The other external control pins remain active unless their respective registers are written to and the appropriate override bit is set, in which case they are ignored until ENSMB is driven low. On powerup and when ENSMB is driven low all registers are reset to their default state. If PRSNT is asserted while ENSMB is high, the registers retain their current state.

**TABLE 1. Equalization Input Select Pins for A and B ports (3-Level Input)**

EQ1	EQ0	Equalization Level	Suggested Use
F	F	Off	Bypass
1	1	Approx. 4 dB at 2.5Ghz	8 inches FR4 (6-mil trace) or less than 1 meter (28 AWG) PCIe cable
0	0	Approx. 9.6 dB at 2.5GHz	14 inches FR4 (6-mil trace) or 1 meter (28 AWG) PCIe cable
F	0	Approx. 11.4 dB at 2.5Ghz	20 inches FR4 (6-mil trace) or 5 meters (26 AWG) PCIe cable
1	0	Approx. 15.5 dB at 2.5Ghz	30 inches FR4 (6-mil trace) or 7 meters (24 AWG) PCIe cable
F	1	Approx. 17 dB at 2.5Ghz	40 inches FR4 (6-mil trace) or 9 meters (24 AWG) PCIe cable
0	1	Approx.19.1 dB at 2.5Ghz	50 inches FR4 (6-mil trace) or 10 meters (24 AWG) PCIe cable
0	F	Approx. 20.6 dB at 2.5Ghz	15 meters (24 AWG) PCIe cable
1	F	Approx. 26.3 dB at 2.5Ghz	>15 meters (24 AWG) PCIe cable

F=Float (don't drive pin, each float pin has an internal 50K Ohm resistor to VDD and GND), 1=High, 0=Low

**TABLE 2. De-Emphasis Input Select Pins for A and B ports (3-Level Input)**

RATE	DEM1	DEM0	Typical De-Emphasis Level	Typical DE Pulse Width	Typical VOD	Suggested Use
0/F	0	0	0dB	0ps	1000mV	
0/F	0	1	-3.5dB	400ps	1000mV	8 inches FR4 (6-mil trace) or less than 1 meter (28 AWG) PCIe cable
0/F	1	0	-6dB	400ps	1000mV	
0/F	1	1	-6dB	400ps enhanced	1000mV	15 inches FR4 (6-mil trace)
0/F	0	F	-9dB	400ps enhanced	1000mV	
0/F	1	F	-12dB	400ps enhanced	1000mV	
0/F	F	0	-9dB	400ps enhanced	1200mV	30 inches FR4 (6-mil trace)
0/F	F	1	-12dB	400ps enhanced	1400mV	40 inches FR4 (6-mil trace)
0/F	F	F	Reserved, don't use			
1/F	0	0	0dB	0ps	1000mV	
1/F	0	1	-3.5dB	200ps	1000mV	
1/F	1	0	-6dB	200ps	1000mV	
1/F	1	1	-6dB	200ps enhanced	1000mV	10 inches FR4 (6-mil trace)
1/F	0	F	-9dB	200ps enhanced	1000mV	
1/F	1	F	-12dB	200ps enhanced	1000mV	
1/F	F	0	-9dB	200ps enhanced	1200mV	20 inches FR4 (6-mil trace)
1/F	F	1	-12dB	200ps enhanced	1400mV	30 inches FR4 (6-mil trace)
1/F	F	F	Reserved, don't use			

F=Float (don't drive pin - (each float pin has an internal 50K Ohm resistor to VDD and GND). Enhanced DE Pulse width provides additional de-emphasis on second bit. VOD = Voltage Output Differential amplitude. When RATE is floated (F=Auto Rate Detection Active) DE Level and Pulse Width settings follow detected RATE. RATE=0 is 2.5GBps, RATE=1 is 5 GBps

**TABLE 3. Idle Control (3-Level Input)**

www.DataSheet4U.com

TXIDLEA/B	Function
0	This state is for lossy media, dedicated Idle threshold detect circuit disabled, output follows input based on EQ settings. Idle state not guaranteed.
Float	Float enables automatic idle detection. Idle on the input is passed to the output. This is the recommended default state. Output driven to Idle if diff input signal less than value set by SD_TH pin.
1	Manual override, output forced to Idle. Diff inputs are ignored.

**TABLE 4. Receiver Electrical Idle Detect Threshold Adjust (Analog input - connect Resistor to GND or Float)**

SD_TH resistor value ( $\Omega$ ) (connect from pin to GND)	Typical Receiver Electrical Idle Detect Threshold (DIFF p-p)
Float (no resistor required)	130mV (default condition)
0	225mV
80K	20mV

SD\_TH resistor value can be set from 0 through 80K Ohms to achieve desired idle detect threshold, see *Figure 1*. 8K Ohm is approx 130mV.

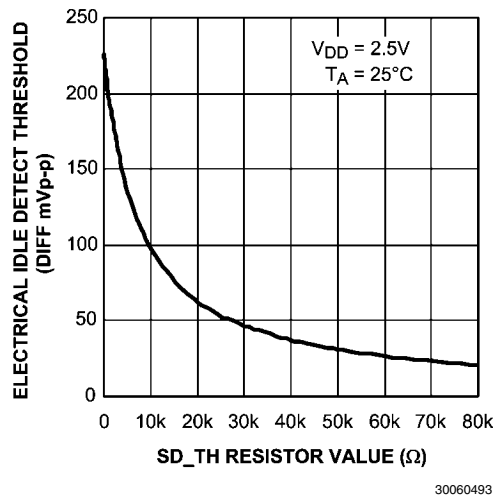

**FIGURE 1. Typical Idle threshold vs SD\_TH resistor value**

**TABLE 5. Receiver Detect Pins for A and B ports (LVCMOS inputs)**

PRSNT#	ENRXDET	RXDETA/B	Function
0	1	0	Disable RXDETA termination mode: Rx detection state machine disabled. Input termination $>50K\Omega$ . Associated output channels in low power idle mode.
0	1	1	Force RXDETA termination mode: Rx detection state machine disabled. Input termination $50\Omega$ . Associated output channels set to active.
1	X	X	Power down mode: Input termination $50\Omega$ . Associated output channels off. Part in power saving mode.

**USING RXDETA/B IN A PCIe ENVIRONMENT**

In order for upstream and downstream PCIe subsystems to communicate in a cabling environment, the PCIe specification includes several auxiliary or sideband signals to manage system-level functionality or implementation. Similar methods are used in backplane applications, but the exact implementation falls outside the PCIe standard. Initial communication from the downstream subsystem to the upstream subsystem

is done with the CPRSNT# auxiliary signal. The CPRSNT# signal is asserted Low by the downstream componentry after the "Power Good" condition has been established. This mechanism allows for the upstream subsystem to determine whether the power is good within the downstream subsystem, enable the reference clock, and initiate the Link Training Sequence.

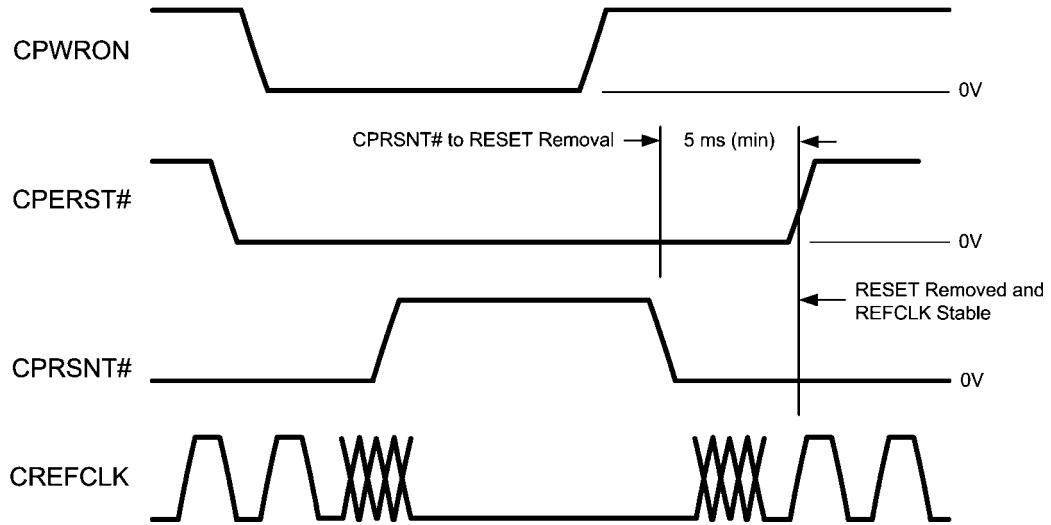

30060412

**FIGURE 2. Typical PCIe System Timing**

The signals shown in the graphic could be easily replicated within the downstream subsystem and used to control the RXDETA/B inputs on the DS50PCI401. Often an onboard microcontroller will be used to handle events like power-up, power-down, power saving modes, and hot insertion. The microcontroller would use the same information to determine

when to enable and disable the DS50PCI401 input termination. In applications that require SMBus control, the microcontroller could also delay any response to the upstream subsystem to allow sufficient time to correctly program the DS50PCI401 and other devices on the board.



## Absolute Maximum Ratings (Note 1)

www.DataSheet4U.com

If Military/Aerospace specified devices are required, please contact the National Semiconductor Sales Office/Distributors for availability and specifications.

Supply Voltage (VDD)	-0.5V to +3.0V
LVC MOS Input/Output Voltage	-0.5V to +4.0V
CML Input Voltage	-0.5V to (VDD+0.5V)
CML Input Current	-30 to +30 mA
LPDS Output Voltage	-0.5V to (VDD+0.5V)
Analog (SD_TH)	-0.5V to (VDD+0.5V)
Junction Temperature	+125°C
Storage Temperature	-40°C to +125°C
Lead Temperature Range	
Soldering (4 sec.)	+260°C
Maximum Package Power Dissipation at 25°C	
SQA54A Package	4.21 W
Derate SQA54A Package	52.6mW/°C above +25°C

## ESD Rating

HBM, STD - JESD22-A114C	≥6 kV
MM, STD - JESD22-A115-A	≥250 V
CDM, STD - JESD22-C101-C	≥1250 V

## Thermal Resistance

$\theta_{JC}$	11.5°C/W
$\theta_{JA}$ , No Airflow, 4 layer JEDEC	19.1°C/W

## Recommended Operating Conditions

	Min	Typ	Max	Units
Supply Voltage				
V <sub>DD</sub> to GND	2.375	2.5	2.625	V
Ambient Temperature	-10	25	+85	°C
SMBus (SDA, SCL)			3.6	V
Supply Noise Tolerance up to 50Mhz (Note 4)			100	mV pp

## Electrical Characteristics

Over recommended operating supply and temperature ranges with default register settings unless other specified. (Notes 2, 3)

Symbol	Parameter	Conditions	Min	Typ	Max	Units
<b>POWER (Note 12)</b>						
PD	Power Dissipation	EQX=Float, DEX=0, VOD=1Vpp, PRSNT=0		758	950	mW
		PRSNT=1, ENSMB=0		0.92	1.125	mW
<b>LVC MOS / LVTTL DC SPECIFICATIONS</b>						
V <sub>IH</sub>	High Level Input Voltage	(Note 14)	2		3.6	V
V <sub>IL</sub>	Low Level Input Voltage	(Note 14)	0		0.8	V
V <sub>OH</sub>	High Level Output Voltage	SMBUS open drain V <sub>OH</sub> set by pullup Resistor				V
V <sub>OL</sub>	Low Level Output Voltage	I <sub>OL</sub> = 4mA			0.4	V
I <sub>IH</sub>	Input High Current	V <sub>IN</sub> = 3.6V, LVC MOS	-15		+15	μA
		V <sub>IN</sub> = 3.6V, w/ FLOAT,PULLDOWN input	-15		+120	
I <sub>IL</sub>	Input Low Current	V <sub>IN</sub> = 0V	-15		+15	μA
		V <sub>IN</sub> = 0V, w/FLOAT input	-80		+15	

Symbol	Parameter	Conditions	Min	Typ	Max	Units
<b>CML RECEIVER INPUTS (IN<sub>n+</sub>, IN<sub>n-</sub>)</b>						
RL <sub>RX-DIFF</sub>	Rx package plus Si differential return loss	0.05GHz – 1.25GHz (Note 5)		-21		dB
		1.25GHz – 2.5GHz (Note 5)		-20		
RL <sub>RX-CM</sub>	Common mode Rx return loss	0.05GHz - 2.5GHz (Note 5)		-11.5		dB
Z <sub>RX-DC</sub>	Rx DC common mode impedance	Tested at VDD=0	40	50	60	Ω
Z <sub>RX-DIFF-DC</sub>	Rx DC differential impedance	Tested at VDD=0	85	100	115	Ω
V <sub>RX-DIFF-DC</sub>	Differential Rx peak to peak voltage	Tested at DC, TXIDLEx=0	0.10		1.2	V
Z <sub>RX-HIGH-IMP-DC -POS</sub>	DC Input CM impedance for V>0	Vin = 0 to 200 mV, RXDETA/B = 0, ENSMB = 0, VDD=2.625	50			KΩ
V <sub>RX-IDLE-DET-DIFF-PP</sub>	Electrical Idle detect threshold	SD_TH = float, see <i>Table 4</i> , (Note 15)	40		175	mV <sub>P-P</sub>
<b>LPDS OUTPUTS (OUT<sub>n+</sub>, OUT<sub>n-</sub>)</b>						
V <sub>TX-DIFF-PP</sub>	Output Voltage Swing	Differential measurement with OUT <sub>n+</sub> and OUT <sub>n-</sub> terminated by 50Ω to GND AC-Coupled, <i>Figure 4</i> , (Note 12)	800	1000	1200	mV <sub>P-P</sub>
V <sub>OCM</sub>	Output Common-Mode Voltage	Single-ended measurement DC-Coupled with 50Ω termination, (Note 2)		V <sub>DD</sub> - 1.4		V
V <sub>TX-DE-RATIO-3.5</sub>	Tx de-emphasis level ratio	VOD = 1000 mV, DEM1 = GND, DEM0 = VDD, (Note 2), (Note 11)		3.5		dB
V <sub>TX-DE-RATIO-6</sub>	Tx de-emphasis level ratio	VOD = 1000 mV, DEM1 = VDD, DEM0 = GND, (Note 2), (Note 11)		6		dB
T <sub>TX-HF-DJ-DD</sub>	Tx Dj > 1.5 Mhz	(Note 6)			0.15	UI
T <sub>TX-LF-RMS</sub>	Tx RMS jitter < 1.5Mhz	(Note 6)			3.0	ps RMS
T <sub>TX-RISE-FALL</sub>	Transmitter Rise/ Fall Time	20% to 80% of differential output voltage, <i>Figure 3</i> (Notes 2, 7)	50	67		ps
T <sub>RF-MISMATCH</sub>	Tx rise/fall mismatch	20% to 80% of differential output voltage (Notes 2, 7)		0.01	0.1	UI
RL <sub>TX-DIFF</sub>	Differential Output Return Loss	0.05- 1.25 Ghz, See <i>Figure 6</i>		-23		dB
		1.25- 2.5 Ghz, See <i>Figure 6</i>		-20		dB
RL <sub>TX-CM</sub>	Common Mode Return Loss	0.05- 2.5 Ghz, See <i>Figure 6</i>		-11		dB
Z <sub>TX-DIFF-DC</sub>	DC differential Tx impedance			100		Ω
V <sub>TX-CM-AC-PP</sub>	Tx AC common mode voltage				100	mVpp
I <sub>TX-SHORT</sub>	transmitter short circuit current limit	Total current transmitter can supply when shorted to VDD or GND			90	mA
V <sub>TX-CM-DC- ACTIVE-IDLE- DELTA</sub>	Absolute Delta of DC Common Mode Voltage during L0 and electrical Idle				40	mV

Symbol	Parameter	Conditions	Min	Typ	Max	Units
$V_{TX-CM-DC-LINE-DELTA}$	Absolute Delta of DC Common Mode Voltage between Tx+ and Tx-				25	mV
$T_{TX-IDLE-SET-TO-IDLE}$	Max time to transition to valid diff signaling after leaving Electrical Idle	VIN = 800 mVp-p, 5 Gbps, <i>Figure 5</i>		6.5	9.5	nS
$T_{TX-IDLE-TO-DIFF-DATA}$	Max time to transition to valid diff signaling after leaving Electrical Idle	VIN = 800 mVp-p, 5 Gbps, <i>Figure 5</i>		5.5	8	nS
$T_{PDEQ}$	Differential Propagation Delay	EQ = 11, +4.0 dB @ 2.5 GHz, <i>Figure 4</i> (Note 9)	150	200	250	ps
$T_{PD}$	Differential Propagation Delay	EQ = FF, Equalizer Bypass, <i>Figure 4</i> (Notes 9, 8)	120	170	220	ps
$T_{LSK}$	Lane to Lane Skew in a Single Part	$T_A = 25C, V_{DD} = 2.5V$ (Notes 7, 8)			27	ps
$T_{PPSK}$	Part to Part Propagation Delay Skew	$T_A = 25C, V_{DD} = 2.5V$			35	ps

Symbol	Parameter	Conditions	Min	Typ	Max	Units
<b>EQUALIZATION</b>						
DJE1	Residual Deterministic Jitter at 5 Gbps	42" of 5 mil stripline FR4, EQ1,0=F,1; K28.5 pattern, DEMx=0, Tx Launch Amplitude 1.0 Vp-p, SD_TH=F. (Notes 2, 10)		0.02	0.09	UI <sub>p,p</sub>
DJE2	Residual Deterministic Jitter at 2.5 Gbps	42" of 5 mil stripline FR4, EQ1,0=F,1; K28.5 pattern, DEMx=0, Tx Launch Amplitude 1.0 Vp-p, SD_TH=F. (Notes 2, 10)		0.02	0.04	UI <sub>p,p</sub>
DJE3	Residual Deterministic Jitter at 5 Gbps	7 meters of 24 AWG PCIe cable, EQ1,0=1,0; K28.5 pattern, DEMx=0, Tx Launch Amplitude 1.0 Vp-p, SD_TH=F. (Notes 2, 10)		0.02	0.11	UI <sub>p,p</sub>
DJE4	Residual Deterministic Jitter at 2.5 Gbps	7 meters of 24 AWG PCIe cable, EQ1,0=1,0; K28.5 pattern, DEMx=0, Tx Launch Amplitude 1.0 Vp-p, SD_TH=F. (Notes 2, 10)		0.03	0.07	UI <sub>p,p</sub>
RJ	Random Jitter	Tx Launch Amplitude 1.0 Vp-p, SD_TH=F, Repeating 1100b (D24.3) pattern. (Note 2)		<0.5		psrms

<b>DE-EMPHASIS</b>						
DJD1	Residual Deterministic Jitter at 5 Gbps	28" of 5 mil stripline FR4, EQ1,0=F,F; K28.5 pattern, DEM1,0=F,1; Tx Launch Amplitude 1.0 Vp-p, SD_TH=F. (Notes 2, 10)		0.02	0.09	UI <sub>p,p</sub>
DJD2	Residual Deterministic Jitter at 2.5 Gbps	28" of 5 mil microstrip FR4, EQ1,0=F,F; K28.5 pattern, DEM1,0=F,0; Tx Launch Amplitude 1.0 Vp-p, SD_TH=F. (Notes 2, 10)		0.03	0.05	UI <sub>p,p</sub>
DJD3	Residual Deterministic Jitter at 5 Gbps	7 meters of 24 AWG PCIe cable, EQ1,0=F,F; K28.5 pattern, DEM1,0=F,1; Tx Launch Amplitude 1.0 Vp-p, SD_TH=F. (Notes 2, 10)		0.03	0.13	UI <sub>p,p</sub>
DJD4	Residual Deterministic Jitter at 2.5 Gbps	7 meters of 24 AWG PCIe cable, EQ1,0=F,F; K28.5 pattern, DEM1,0=F,0; Tx Launch Amplitude 1.0 Vp-p, SD_TH=F. (Notes 2, 10)		0.04	0.06	UI <sub>p,p</sub>

**Note 1:** "Absolute Maximum Ratings" indicate limits beyond which damage to the device may occur, including inoperability and degradation of device reliability and/or performance. Functional operation of the device and/or non-degradation at the Absolute Maximum Ratings or other conditions beyond those indicated in the Recommended Operating Conditions is not implied. The Recommended Operating Conditions indicate conditions at which the device is functional and the device should not be operated beyond such conditions. Absolute Maximum Numbers are guaranteed for a junction temperature range of -40°C to +125°C. Models are validated to Maximum Operating Voltages only.

**Note 2:** Typical values represent most likely parametric norms at V<sub>DD</sub> = 2.5V, T<sub>A</sub> = 25°C., and at the Recommended Operation Conditions at the time of product characterization and are not guaranteed.

**Note 3:** The Electrical Characteristics tables list guaranteed specifications under the listed Recommended Operating Conditions except as otherwise modified or specified by the Electrical Characteristics Conditions and/or Notes. Typical specifications are estimations only and are not guaranteed.

**Note 4:** Allowed supply noise (mV<sub>p,p</sub> sine wave) under typical conditions.

**Note 5:** Input Return Loss also uses the setup shown in Figure 6. The blocking / biasing circuit is replaced with a simple AC coupling capacitor for each input to emulate a typical PCIe application.

**Note 6:** PCIe 2.0 transmit jitter specifications - actual device jitter is much less. Actual device Rj and Dj has been characterized and specified with test loads outlined in the EQUALIZATION and DE-EMPHASIS sections of the Electrical Characteristics table.

**Note 7:** Guaranteed by device characterization

**Note 8:** Propagation Delay measurements for Part to Part skew are all based on devices operating under identical temperature and supply voltage conditions.

**Note 9:** Propagation Delay measurements will change slightly based on the level of EQ selected. EQ Bypass will result in the shortest propagation delays.

**Note 10:** Residual DJ measurements subtract out deterministic jitter present at the generator outputs. For 2.5 Gbps generator Dj = 0.0275 UI and for 5.0 Gbps generator Dj = 0.035 UI.

**Note 11:** Measured with a repeating K28.5 pattern at a data rate of 2.5 Gbps and 5.0 Gbps.

**Note 12:** Measured with DEM Select pins configured for 1000mV VOD, see De-emphasis table.

**Note 13:** Measured at default SD\_TH settings

**Note 14:** Input edge rate for LVCMOS/FLOAT inputs must be 50ns minimum from 10-90%.

**Note 15:** Measured at package pins of receiver. Less than 40mV is IDLE, greater than 175mV is ACTIVE. SD\_TH pin connected with resistor to GND overrides this default setting.

## Electrical Characteristics — Serial Management Bus Interface

Over recommended operating supply and temperature ranges unless other specified.

Symbol	Parameter	Conditions	Min	Typ	Max	Units
<b>SERIAL BUS INTERFACE DC SPECIFICATIONS</b>						
$V_{IL}$	Data, Clock Input Low Voltage				0.8	V
$V_{IH}$	Data, Clock Input High Voltage		2.1		3.6	V
$I_{PULLUP}$	Current Through Pull-Up Resistor or Current Source	High Power Specification	4			mA
$V_{DD}$	Nominal Bus Voltage		2.375		3.6	V
$I_{LEAK-BUS}$	Input Leakage Per Bus Segment	(Note 16)	-200		+200	$\mu$ A
$I_{LEAK-Pin}$	Input Leakage Per Device Pin			-15		$\mu$ A
$C_I$	Capacitance for SDA and SDC	(Notes 16, 17)			10	pF
$R_{TERM}$	External Termination Resistance pull to $V_{DD} = 2.5V \pm 5\%$ OR $3.3V \pm 10\%$	Pullup $V_{DD} = 3.3V$ , (Notes 16, 17, 18)		2000		$\Omega$
		Pullup $V_{DD} = 2.5V$ , (Notes 16, 17, 18)		1000		$\Omega$
<b>SERIAL BUS INTERFACE TIMING SPECIFICATIONS. See Figure 7</b>						
FSMB	Bus Operating Frequency	(Note 19)	10		100	kHz
TBUF	Bus Free Time Between Stop and Start Condition		4.7			$\mu$ s
THD:STA	Hold time after (Repeated) Start Condition. After this period, the first clock is generated.	At $I_{PULLUP}$ , Max	4.0			$\mu$ s
TSU:STA	Repeated Start Condition Setup Time		4.7			$\mu$ s
TSU:STO	Stop Condition Setup Time		4.0			$\mu$ s
THD:DAT	Data Hold Time		300			ns
TSU:DAT	Data Setup Time		250			ns
$T_{TIMEOUT}$	Detect Clock Low Timeout	(Note 19)	25		35	ms
$T_{LOW}$	Clock Low Period		4.7			$\mu$ s
$T_{HIGH}$	Clock High Period	(Note 19)	4.0		50	$\mu$ s
$T_{LOW:SEXT}$	Cumulative Clock Low Extend Time (Slave Device)	(Note 19)			2	ms
$t_F$	Clock/Data Fall Time	(Note 19)			300	ns
$t_R$	Clock/Data Rise Time	(Note 19)			1000	ns
$t_{POR}$	Time in which a device must be operational after power-on reset	(Note 19)			500	ms

**Note 16:** Recommended value. Parameter not tested in production.

**Note 17:** Recommended maximum capacitance load per bus segment is 400pF.

**Note 18:** Maximum termination voltage should be identical to the device supply voltage.

**Note 19:** Compliant to SMBus 2.0 physical layer specification. See System Management Bus (SMBus) Specification Version 2.0, section 3.1.1 SMBus common AC specifications for details.

# Timing Diagrams

www.DataSheet4U.com

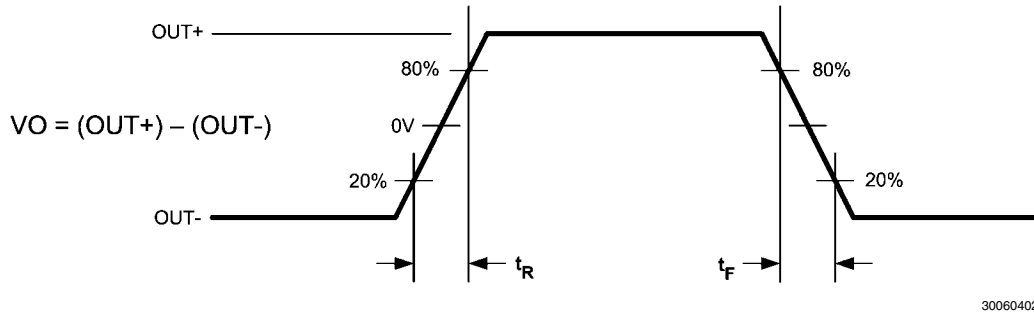

FIGURE 3. CML Output Transition Times

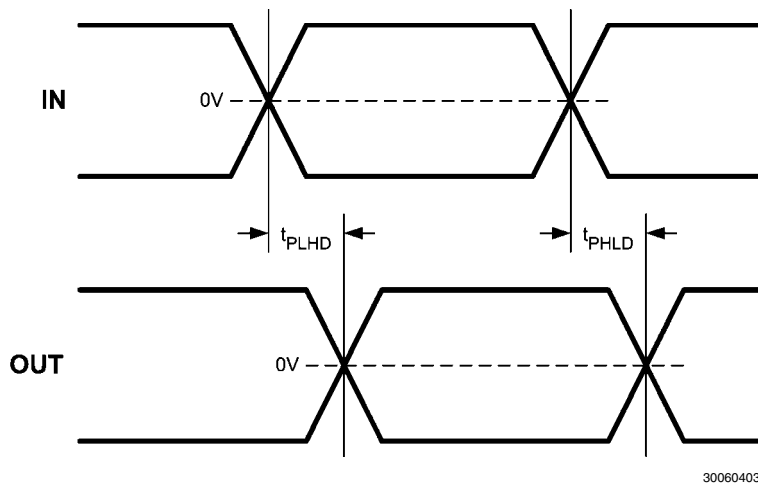

FIGURE 4. Propagation Delay Timing Diagram

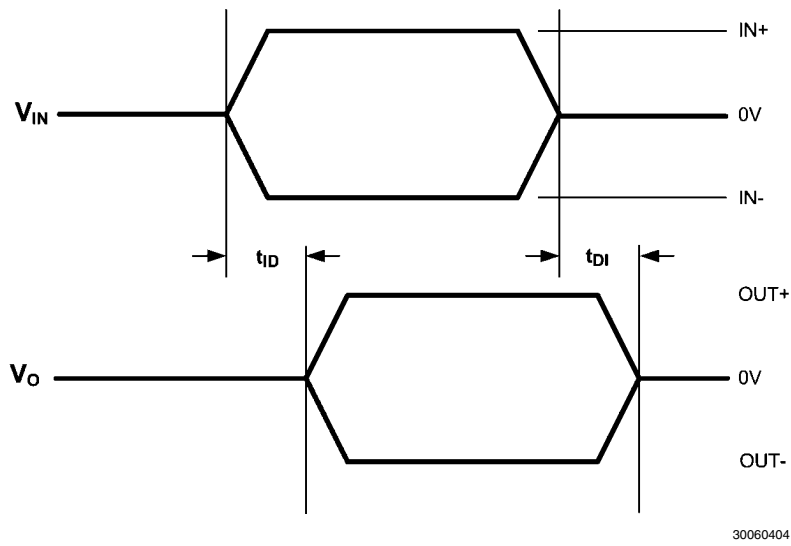

FIGURE 5. Idle Timing Diagram

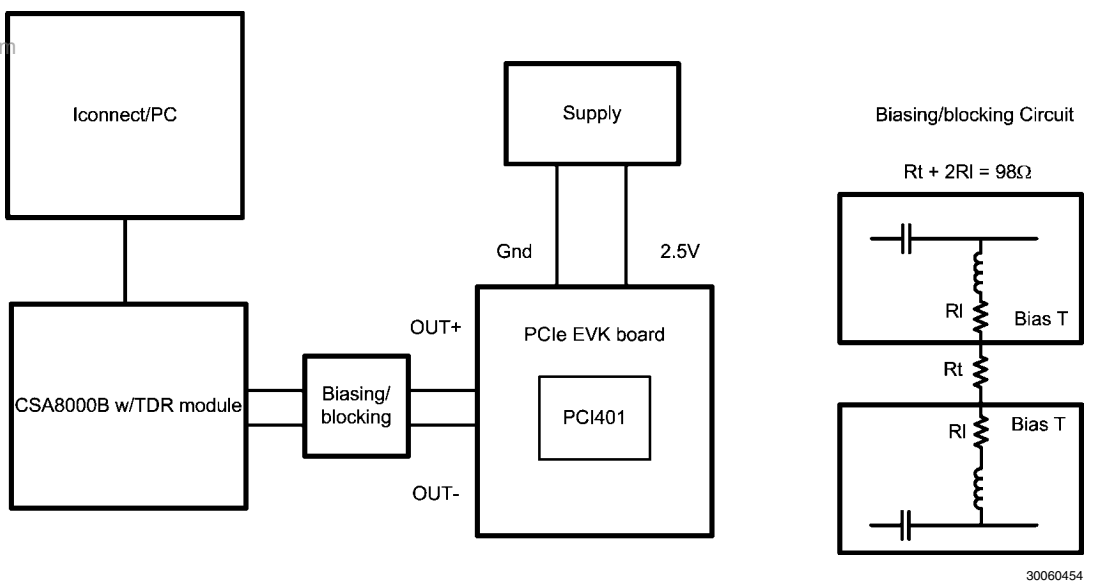

FIGURE 6. Input and Output Return Loss Setup

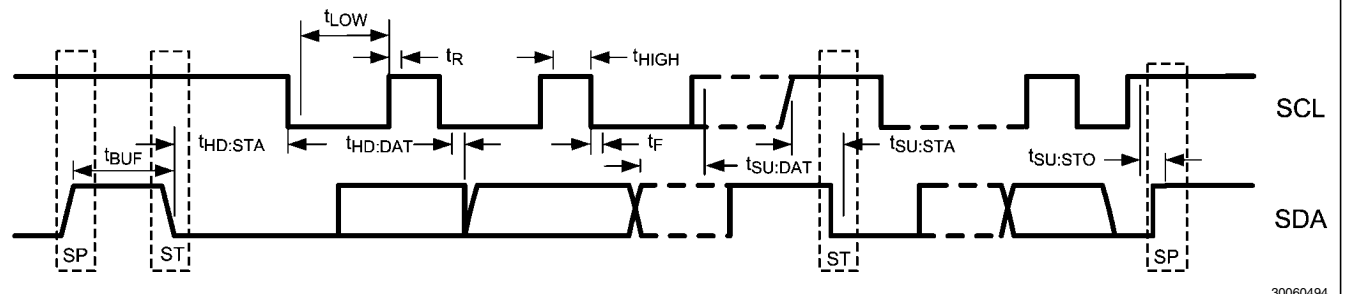

FIGURE 7. SMBus Timing Parameters



## System Management Bus (SMBus) and Configuration Registers

The System Management Bus interface is compatible to SMBus 2.0 physical layer specification. ENSMB must be pulled high to enable SMBus mode and allow access to the configuration registers.

The DS50PCI401 has the AD[3:0] inputs in SMBus mode. These pins are the user set SMBus slave address inputs. The AD[3:0] pins have internal pull-down. When left floating or pulled low the AD[3:0] = 0000'b, the device default address byte is A0'h. Based on the SMBus 2.0 specification, the DS50PCI401 has a 7-bit slave address of 1010000'b. The LSB is set to 0'b (for a WRITE), thus the 8-bit value is 1010 0000'b or A0'h. The device address byte can be set with the use of the AD[3:0] inputs. Below are some examples.

AD[3:0] = 0001'b, the device address byte is A2'h

AD[3:0] = 0010'b, the device address byte is A4'h

AD[3:0] = 0100'b, the device address byte is A8'h

AD[3:0] = 1000'b, the device address byte is B0'h

The SDC and SDA pins are 3.3V LVCMOS signaling and include high-Z internal pull up resistors. External low impedance pull up resistors maybe required depending upon SMBus loading and speed. Note, these pins are not 5V tolerant.

### TRANSFER OF DATA VIA THE SMBus

During normal operation the data on SDA must be stable during the time when SDC is High.

There are three unique states for the SMBus:

**START:** A High-to-Low transition on SDA while SDC is High indicates a message START condition.

**STOP:** A Low-to-High transition on SDA while SDC is High indicates a message STOP condition.

**IDLE:** If SDC and SDA are both High for a time exceeding  $t_{\text{BUF}}$  from the last detected STOP condition or if they are High for a total exceeding the maximum specification for  $t_{\text{HIGH}}$  then the bus will transfer to the IDLE state.

### SMBus TRANSACTIONS

The device supports WRITE and READ transactions. See Register Description table for register address, type (Read/Write, Read Only), default value and function information.

### WRITING A REGISTER

To write a register, the following protocol is used (see SMBus 2.0 specification).

1. The Host drives a START condition, the 7-bit SMBus address, and a "0" indicating a WRITE.
2. The Device (Slave) drives the ACK bit ("0").
3. The Host drives the 8-bit Register Address.
4. The Device drives an ACK bit ("0").
5. The Host drive the 8-bit data byte.
6. The Device drives an ACK bit ("0").
7. The Host drives a STOP condition.

The WRITE transaction is completed, the bus goes IDLE and communication with other SMBus devices may now occur.

### READING A REGISTER

To read a register, the following protocol is used (see SMBus 2.0 specification).

1. The Host drives a START condition, the 7-bit SMBus address, and a "0" indicating a WRITE.

2. The Device (Slave) drives the ACK bit ("0").
3. The Host drives the 8-bit Register Address.
4. The Device drives an ACK bit ("0").
5. The Host drives a START condition.
6. The Host drives the 7-bit SMBus Address, and a "1" indicating a READ.
7. The Device drives an ACK bit "0".
8. The Device drives the 8-bit data value (register contents).
9. The Host drives a NACK bit "1" indicating end of the READ transfer.
10. The Host drives a STOP condition.

The READ transaction is completed, the bus goes IDLE and communication with other SMBus devices may now occur.

Please see SMBus Register Map Table for more information.

### SMBus REGISTER WRITES:

The DS50PCI401 outputs will NOT be PCIe compliant with the SMBus registers enabled (ENSMB = 1) until the VOD levels have been set. Below is an example to configure the VOD level to a PCIe compliant amplitude and adjust the DE and EQ signal conditioning to work with a 7m PCIe cable interconnect on the input B-side / output A-side of the device

1. Reset the SMBus registers to default values:  
**Write 01'h to address 0x00.**
2. Set VOD = 1.0V for all channels (OA[3:0] and OB[3:0]):  
**Write 0F'h to address 0x10, 0x17, 0x1E, 0x25, 0x2D, 0x34, 0x3B, 0x42.**
3. Set equalization to external pin level EQ[1:0] = 10 (~15.5 dB at 2.5 GHz) for all channels (IB[3:0]):  
**Write 39'h to address 0x0F, 0x16, 0x1D, 0x24.**
4. Set de-emphasis to DE[1:0] = F1 or -12 dB enhanced for all A channels (OA[3:0]):  
**Write A0'h to address 0x2E, 0x35, 0x3C, 0x43.**

### IDLE AND RATE DETECTION TO EXTERNAL PINS

The functions of IDLE and RATE detection to external pins for monitoring can be supported in SMBus mode. The external GPIO pins of 19, 20, 46 and 47 will be changed and they will serve as outputs for IDLE and RATE detect signals.

The following external pins should be set to auto detection:

RATE = F (FLOAT) – auto RATE detect enabled

TXIDLEA/B = F (FLOAT) – auto IDLE detect enabled

There are 4 GPIO pins that can be configured as outputs with reg\_4E[0].

To disable the external SMBus address pins, so pin 46 and 47 can be used as outputs:

### Write 01'h to address 0x4E.

Care must be taken to ensure that only the desired status block is enabled and attached to the external pin as the status blocks can be OR'ed together internally. Register bits reg\_47 [5:4] and bits reg\_4C[7:6] are used to enable each of the status block outputs to the external pins. The channel status blocks can be internally OR'ed together to monitor more than one channel at a time. This allows more information to be presented on the status outputs and later if desired, a diagnosis of the channel identity can be made with additional SMBus writes to register bits reg\_47[5:4] and bits reg\_4C [7:6].

Below are examples to configure the device and bring the internal IDLE and RATE status to pins 19, 20, 46, 47.

To monitor the IDLE detect with two channels ORed (CH0 with CH2, CH1 with CH3, CH4 with CH6, CH5 with CH7):

**Write 32'h to address 0x47.**

The following IDLE status should be observable on the external pins:

- pin 19 – CH0 with CH2,
- pin 20 – CH1 with CH3,
- pin 46 – CH4 with CH6,
- pin 47 – CH5 with CH7.

Pin = HIGH (VDD) means IDLE is detected (no signal present).

Pin = LOW (GND) means ACTIVE (data signal present).

To monitor the RATE detect with two channels ORed (CH0 with CH2, CH1 with CH3, CH4 with CH6, CH5 with CH7):

**Write C0'h to address 0x4C.**

The following RATE status should be observable on the external pins:

- pin 19 – CH0 with CH2,
- pin 20 – CH1 with CH3,
- pin 46 – CH4 with CH6,
- pin 47 – CH5 with CH7.

Pin = HIGH (VDD) means high data rate is detected (6 Gbps).

Pin = LOW (GND) means low rate is detected (3 Gbps).

TABLE 6. SMBus Register Map

Address	Register Name	Bit (s)	Field	Type	Default	Description
0x00	Reset	7:2	Reserved	R/W	0x00	Set bits to 0.
		1	Block SMBus Reset			SMBus Reset Block 0: Allow SMBus reset from bit 0 1: Block SMBus reset from bit 0
		0	Reset			SMBus Reset 1: Reset registers to default value
0x01	PWDN Channels	7:0	PWDN CHx	R/W	0x00	Power Down per Channel [7]: CHA_3 [6]: CHA_2 [5]: CHA_1 [4]: CHA_0 [3]: CHB_3 [2]: CHB_2 [1]: CHB_1 [0]: CHB_0 00'h = all channels enabled FF'h = all channels disabled
0x02	PWDN Control	7:1	Reserved	R/W	0x00	Set bits to 0.
		0	Override PWDN			0: Allow PWDN pin control 1: Block PWDN pin control
0x08	Pin Control Override	7:5	Reserved	R/W	0x00	Set bits to 0.
		4	Override IDLE			0: Allow IDLE pin control 1: Block IDLE pin control
		3	Reserved			Set bit to 0.
		2	Override RATE			0: Allow RATE pin control 1: Block RATE pin control
		1:0	Reserved			Set bits to 0.

0x0E	CH0 - CHB0 IDLE RATE Select	7:6	Reserved	R/W	0x00	Set bits to 0.
		5	IDLE auto			0: Allow IDLE_sel control in Bit 4 1: Automatic IDLE detect
		4	IDLE select			0: Output is muted (electrical idle) 1: Output is ON (SD is disabled)
		3:2	Reserved			Set bits to 0.
		1	RATE auto			0: Allow RATE_sel control in Bit 0 1: Automatic RATE detect
0	RATE select	0: 2.5 Gbps 1: 5.0 Gbps				
0x0F	CH0 - CHB0 EQ Control	7:6	Reserved	R/W	0x20	Set bits to 0.
		5:0	CH0 IB0 EQ			IB0 EQ Control - total of 24 levels (3 gain stages with 8 settings) [5]: Enable EQ [4:3]: Gain Stage Control [2:0]: Boost Level Control Pin [EQ1 EQ0] = Register [EN] [GST] [BST] = Hex Value FF = 100000 = 20'h = Bypass (Default) 11 = 101010 = 2A'h 00 = 110000 = 30'h F0 = 110010 = 32'h 10 = 111001 = 39'h F1 = 110101 = 35'h 01 = 110111 = 37'h 0F = 111011 = 3B'h 1F = 111101 = 3D'h
0x10	CH0 - CHB0 VOD Control	7	Reserved	R/W	0x03	Set bit to 0.
		6:0	CH0 OB0 VOD			OB0 VOD Control 03'h = 600 mV (Default) 07'h = 800 mV 0F'h = 1000 mV 1F'h = 1200 mV 3F'h = 1400 mV
0x11	CH0 - CHB0 DE Control	7:0	CH0 OB0 DEM	R/W	0x03	OB0 DEM Control [7]: DEM TYPE (Compatibility = 0 / Enhanced = 1) [6:0]: DEM Level Control Pin [DEM1 DEM0] = Register [TYPE] [Level Control] = Hex Value 00 = 00000001 = 01'h = 0.0 dB 01 = 00000011 = 03'h = -3.5 dB 10 = 00000101 = 05'h = -6.0 dB 0F = 10001000 = 88'h = -6.0 dB 01 = 10010000 = 90'h = -9.0 dB 1F = 10100000 = A0'h = -12.0 dB F0 = 10010000 = 90'h = -9.0 dB F1 = 10100000 = A0'h = -12.0 dB FF = 11000000 = C0'h = Reserved
0x12	CH0 - CHB0 IDLE Threshold	7:4	Reserved	R/W	0x00	Set bits to 0.
		3:0	IDLE threshold			De-assert = [3:2], assert = [1:0] 00 = 110 mV, 70 mV (Default) 01 = 150 mV, 110 mV 10 = 170 mV, 130 mV 11 = 190 mV, 150 mV

0x15	CH1 - CHB1 IDLE RATE Select	7:6	Reserved	R/W	0x00	Set bits to 0.
		5	IDLE auto			0: Allow IDLE_sel control in Bit 4 1: Automatic IDLE detect
		4	IDLE select			0: Output is muted (electrical idle) 1: Output is ON (SD is disabled)
		3:2	Reserved			Set bits to 0.
		1	RATE auto			0: Allow RATE_sel control in Bit 0 1: Automatic RATE detect
		0	RATE select			0: 2.5 Gbps 1: 5.0 Gbps
0x16	CH1 - CHB1 EQ Control	7:6	Reserved	R/W	0x20	Set bits to 0.
		5:0	CH1 IB1 EQ			IB1 EQ Control - total of 24 levels (3 gain stages with 8 settings) [5]: Enable EQ [4:3]: Gain Stage Control [2:0]: Boost Level Control Pin [EQ1 EQ0] = Register [EN] [GST] [BST] = Hex Value FF = 100000 = 20'h = Bypass (Default) 11 = 101010 = 2A'h 00 = 110000 = 30'h F0 = 110010 = 32'h 10 = 111001 = 39'h F1 = 110101 = 35'h 01 = 110111 = 37'h 0F = 111011 = 3B'h 1F = 111101 = 3D'h
0x17	CH1 - CHB1 VOD Control	7	Reserved	R/W	0x03	Set bit to 0.
		6:0	CH1 OB1 VOD			OB1 VOD Control 03'h = 600 mV (Default) 07'h = 800 mV 0F'h = 1000 mV 1F'h = 1200 mV 3F'h = 1400 mV
0x18	CH1 - CHB1 DE Control	7:0	CH1 OB1 DEM	R/W	0x03	OB1 DEM Control [7]: DEM TYPE (Compatibility = 0 / Enhanced = 1) [6:0]: DEM Level Control Pin [DEM1 DEM0] = Register [TYPE] [Level Control] = Hex Value 00 = 0000001 = 01'h = 0.0 dB 01 = 0000011 = 03'h = -3.5 dB 10 = 0000101 = 05'h = -6.0 dB 0F = 10001000 = 88'h = -6.0 dB 01 = 10010000 = 90'h = -9.0 dB 1F = 10100000 = A0'h = -12.0 dB F0 = 10010000 = 90'h = -9.0 dB F1 = 10100000 = A0'h = -12.0 dB FF = 11000000 = C0'h = Reserved
0x19	CH1 - CHB1 IDLE Threshold	7:4	Reserved	R/W	0x00	Set bits to 0.
		3:0	IDLE threshold			De-assert = [3:2], assert = [1:0] 00 = 110 mV, 70 mV (Default) 01 = 150 mV, 110 mV 10 = 170 mV, 130 mV 11 = 190 mV, 150 mV

0x1C	CH2 - CHB2 IDLE RATE Select	7:6	Reserved	R/W	0x00	Set bits to 0.
		5	IDLE auto			0: Allow IDLE_sel control in Bit 4 1: Automatic IDLE detect
		4	IDLE select			0: Output is muted (electrical idle) 1: Output is ON (SD is disabled)
		3:2	Reserved			Set bits to 0.
		1	RATE auto			0: Allow RATE_sel control in Bit 0 1: Automatic RATE detect
		0	RATE select			0: 2.5 Gbps 1: 5.0 Gbps
0x1D	CH2 - CHB2 EQ Control	7:6	Reserved	R/W	0x20	Set bits to 0.
		5:0	CH2 IB2 EQ			IB2 EQ Control - total of 24 levels (3 gain stages with 8 settings) [5]: Enable EQ [4:3]: Gain Stage Control [2:0]: Boost Level Control Pin [EQ1 EQ0] = Register [EN] [GST] [BST] = Hex Value FF = 100000 = 20'h = Bypass (Default) 11 = 101010 = 2A'h 00 = 110000 = 30'h F0 = 110010 = 32'h 10 = 111001 = 39'h F1 = 110101 = 35'h 01 = 110111 = 37'h 0F = 111011 = 3B'h 1F = 111101 = 3D'h
0x1E	CH2 - CHB2 VOD Control	7	Reserved	R/W	0x03	Set bit to 0.
		6:0	CH2 OB2 VOD			OB2 VOD Control 03'h = 600 mV (Default) 07'h = 800 mV 0F'h = 1000 mV 1F'h = 1200 mV 3F'h = 1400 mV
0x1F	CH2 - CHB2 DE Control	7:0	CH2 OB2 DEM	R/W	0x03	OB2 DEM Control [7]: DEM TYPE (Compatibility = 0 / Enhanced = 1) [6:0]: DEM Level Control Pin [DEM1 DEM0] = Register [TYPE] [Level Control] = Hex Value 00 = 00000001 = 01'h = 0.0 dB 01 = 00000011 = 03'h = -3.5 dB 10 = 00000101 = 05'h = -6.0 dB 0F = 10001000 = 88'h = -6.0 dB 01 = 10010000 = 90'h = -9.0 dB 1F = 10100000 = A0'h = -12.0 dB F0 = 10010000 = 90'h = -9.0 dB F1 = 10100000 = A0'h = -12.0 dB FF = 11000000 = C0'h = Reserved
0x20	CH2 - CHB2 IDLE Threshold	7:4	Reserved	R/W	0x00	Set bits to 0.
		3:0	IDLE threshold			De-assert = [3:2], assert = [1:0] 00 = 110 mV, 70 mV (Default) 01 = 150 mV, 110 mV 10 = 170 mV, 130 mV 11 = 190 mV, 150 mV

0x23	CH3 - CHB3 IDLE RATE Select	7:6	Reserved	R/W	0x00	Set bits to 0.
		5	IDLE auto			0: Allow IDLE_sel control in Bit 4 1: Automatic IDLE detect
		4	IDLE select			0: Output is muted (electrical idle) 1: Output is ON (SD is disabled)
		3:2	Reserved			Set bits to 0.
		1	RATE auto			0: Allow RATE_sel control in Bit 0 1: Automatic RATE detect
		0	RATE select			0: 2.5 Gbps 1: 5.0 Gbps
0x24	CH3 - CHB3 EQ Control	7:6	Reserved	R/W	0x20	Set bits to 0.
		5:0	CH3 IB3 EQ			IB3 EQ Control - total of 24 levels (3 gain stages with 8 settings) [5]: Enable EQ [4:3]: Gain Stage Control [2:0]: Boost Level Control Pin [EQ1 EQ0] = Register [EN] [GST] [BST] = Hex Value FF = 100000 = 20'h = Bypass (Default) 11 = 101010 = 2A'h 00 = 110000 = 30'h F0 = 110010 = 32'h 10 = 111001 = 39'h F1 = 110101 = 35'h 01 = 110111 = 37'h 0F = 111011 = 3B'h 1F = 111101 = 3D'h
0x25	CH3 - CHB3 VOD Control	7	Reserved	R/W	0x03	Set bit to 0.
		6:0	CH3 OB3 VOD			OB3 VOD Control 03'h = 600 mV (Default) 07'h = 800 mV 0F'h = 1000 mV 1F'h = 1200 mV 3F'h = 1400 mV
0x26	CH3 - CHB3 DE Control	7:0	CH3 OB3 DEM	R/W	0x03	OB3 DEM Control [7]: DEM TYPE (Compatibility = 0 / Enhanced = 1) [6:0]: DEM Level Control Pin [DEM1 DEM0] = Register [TYPE] [Level Control] = Hex Value 00 = 0000001 = 01'h = 0.0 dB 01 = 0000011 = 03'h = -3.5 dB 10 = 0000101 = 05'h = -6.0 dB 0F = 10001000 = 88'h = -6.0 dB 01 = 10010000 = 90'h = -9.0 dB 1F = 10100000 = A0'h = -12.0 dB F0 = 10010000 = 90'h = -9.0 dB F1 = 10100000 = A0'h = -12.0 dB FF = 11000000 = C0'h = Reserved
0x27	CH3 - CHB3 IDLE Threshold	7:4	Reserved	R/W	0x00	Set bits to 0.
		3:0	IDLE threshold			De-assert = [3:2], assert = [1:0] 00 = 110 mV, 70 mV (Default) 01 = 150 mV, 110 mV 10 = 170 mV, 130 mV 11 = 190 mV, 150 mV

0x2B	CH4 - CHA0 IDLE RATE Select	7:6	Reserved	R/W	0x00	Set bits to 0.
		5	IDLE auto			0: Allow IDLE_sel control in Bit 4 1: Automatic IDLE detect
		4	IDLE select			0: Output is muted (electrical idle) 1: Output is ON (SD is disabled)
		3:2	Reserved			Set bits to 0.
		1	RATE auto			0: Allow RATE_sel control in Bit 0 1: Automatic RATE detect
		0	RATE select			0: 2.5 Gbps 1: 5.0 Gbps
0x2C	CH4 - CHA0 EQ Control	7:6	Reserved	R/W	0x20	Set bits to 0.
		5:0	CH4 IA0 EQ			IA0 EQ Control - total of 24 levels (3 gain stages with 8 settings) [5]: Enable EQ [4:3]: Gain Stage Control [2:0]: Boost Level Control Pin [EQ1 EQ0] = Register [EN] [GST] [BST] = Hex Value FF = 100000 = 20'h = Bypass (Default) 11 = 101010 = 2A'h 00 = 110000 = 30'h F0 = 110010 = 32'h 10 = 111001 = 39'h F1 = 110101 = 35'h 01 = 110111 = 37'h 0F = 111011 = 3B'h 1F = 111101 = 3D'h
0x2D	CH4 - CHA0 VOD Control	7	Reserved	R/W	0x03	Set bit to 0.
		6:0	CH4 OA0 VOD			OA0 VOD Control 03'h = 600 mV (Default) 07'h = 800 mV 0F'h = 1000 mV 1F'h = 1200 mV 3F'h = 1400 mV
0x2E	CH4 - CHA0 DE Control	7:0	CH4 OA0 DEM	R/W	0x03	OA0 DEM Control [7]: DEM TYPE (Compatibility = 0 / Enhanced = 1) [6:0]: DEM Level Control Pin [DEM1 DEM0] = Register [TYPE] [Level Control] = Hex Value 00 = 00000001 = 01'h = 0.0 dB 01 = 00000011 = 03'h = -3.5 dB 10 = 00000101 = 05'h = -6.0 dB 0F = 10001000 = 88'h = -6.0 dB 01 = 10010000 = 90'h = -9.0 dB 1F = 10100000 = A0'h = -12.0 dB F0 = 10010000 = 90'h = -9.0 dB F1 = 10100000 = A0'h = -12.0 dB FF = 11000000 = C0'h = Reserved
0x2F	CH4 - CHA0 IDLE Threshold	7:4	Reserved	R/W	0x00	Set bits to 0.
		3:0	IDLE threshold			De-assert = [3:2], assert = [1:0] 00 = 110 mV, 70 mV (Default) 01 = 150 mV, 110 mV 10 = 170 mV, 130 mV 11 = 190 mV, 150 mV



0x32	CH5 - CHA1 IDLE RATE Select	7:6	Reserved	R/W	0x00	Set bits to 0.
		5	IDLE auto			0: Allow IDLE_sel control in Bit 4 1: Automatic IDLE detect
		4	IDLE select			0: Output is muted (electrical idle) 1: Output is ON (SD is disabled)
		3:2	Reserved			Set bits to 0.
		1	RATE auto			0: Allow RATE_sel control in Bit 0 1: Automatic RATE detect
		0	RATE select			0: 2.5 Gbps 1: 5.0 Gbps
0x33	CH5 - CHA1 EQ Control	7:6	Reserved	R/W	0x20	Set bits to 0.
		5:0	CH5 IA1 EQ			IA1 EQ Control - total of 24 levels (3 gain stages with 8 settings) [5]: Enable EQ [4:3]: Gain Stage Control [2:0]: Boost Level Control Pin [EQ0 EQ1] = Register [EN] [GST] [BST] = Hex Value FF = 100000 = 20'h = Bypass (Default) 11 = 101010 = 2A'h 00 = 110000 = 30'h F0 = 110010 = 32'h 10 = 111001 = 39'h F1 = 110101 = 35'h 01 = 110111 = 37'h 0F = 111011 = 3B'h 1F = 111101 = 3D'h
0x34	CH5 - CHA1 VOD Control	7	Reserved	R/W	0x03	Set bit to 0.
		6:0	CH5 OA1 VOD			OA1 VOD Control 03'h = 600 mV (Default) 07'h = 800 mV 0F'h = 1000 mV 1F'h = 1200 mV 3F'h = 1400 mV
0x35	CH5 - CHA1 DE Control	7:0	CH5 OA1 DEM	R/W	0x03	OA1 DEM Control [7]: DEM TYPE (Compatibility = 0 / Enhanced = 1) [6:0]: DEM Level Control Pin [DEM1 DEM0] = Register [TYPE] [Level Control] = Hex Value 00 = 0000001 = 01'h = 0.0 dB 01 = 0000011 = 03'h = -3.5 dB 10 = 0000101 = 05'h = -6.0 dB 0F = 10001000 = 88'h = -6.0 dB 01 = 10010000 = 90'h = -9.0 dB 1F = 10100000 = A0'h = -12.0 dB F0 = 10010000 = 90'h = -9.0 dB F1 = 10100000 = A0'h = -12.0 dB FF = 11000000 = C0'h = Reserved
0x36	CH5 - CHA1 IDLE Threshold	7:4	Reserved	R/W	0x00	Set bits to 0.
		3:0	IDLE threshold			De-assert = [3:2], assert = [1:0] 00 = 110 mV, 70 mV (Default) 01 = 150 mV, 110 mV 10 = 170 mV, 130 mV 11 = 190 mV, 150 mV

0x39	CH6 - CHA2 IDLE RATE Select	7:6	Reserved	R/W	0x00	Set bits to 0.
		5	IDLE auto			0: Allow IDLE_sel control in Bit 4 1: Automatic IDLE detect
		4	IDLE select			0: Output is muted (electrical idle) 1: Output is ON (SD is disabled)
		3:2	Reserved			Set bits to 0.
		1	RATE auto			0: Allow RATE_sel control in Bit 0 1: Automatic RATE detect
		0	RATE select			0: 2.5 Gbps 1: 5.0 Gbps
0x3A	CH6 - CHA2 EQ Control	7:6	Reserved	R/W	0x20	Set bits to 0.
		5:0	CH6 IA2 EQ			IA2 EQ Control - total of 24 levels (3 gain stages with 8 settings) [5]: Enable EQ [4:3]: Gain Stage Control [2:0]: Boost Level Control Pin [EQ1 EQ0] = Register [EN] [GST] [BST] = Hex Value FF = 100000 = 20'h = Bypass (Default) 11 = 101010 = 2A'h 00 = 110000 = 30'h F0 = 110010 = 32'h 10 = 111001 = 39'h F1 = 110101 = 35'h 01 = 110111 = 37'h 0F = 111011 = 3B'h 1F = 111101 = 3D'h
0x3B	CH6 - CHA2 VOD Control	7	Reserved	R/W	0x03	Set bit to 0.
		6:0	CH6 OA2 VOD			OA2 VOD Control 03'h = 600 mV (Default) 07'h = 800 mV 0F'h = 1000 mV 1F'h = 1200 mV 3F'h = 1400 mV
0x3C	CH6 - CHA2 DE Control	7:0	CH6 OA2 DEM	R/W	0x03	OA2 DEM Control [7]: DEM TYPE (Compatibility = 0 / Enhanced = 1) [6:0]: DEM Level Control Pin [DEM1 DEM0] = Register [TYPE] [Level Control] = Hex Value 00 = 00000001 = 01'h = 0.0 dB 01 = 00000011 = 03'h = -3.5 dB 10 = 00000101 = 05'h = -6.0 dB 0F = 10001000 = 88'h = -6.0 dB 01 = 10010000 = 90'h = -9.0 dB 1F = 10100000 = A0'h = -12.0 dB F0 = 10010000 = 90'h = -9.0 dB F1 = 10100000 = A0'h = -12.0 dB FF = 11000000 = C0'h = Reserved
0x3D	CH6 - CHA2 IDLE Threshold	7:4	Reserved	R/W	0x00	Set bits to 0.
		3:0	IDLE threshold			De-assert = [3:2], assert = [1:0] 00 = 110 mV, 70 mV (Default) 01 = 150 mV, 110 mV 10 = 170 mV, 130 mV 11 = 190 mV, 150 mV

0x40	CH7 - CHA3 IDLE RATE Select	7:6	Reserved	R/W	0x00	Set bits to 0.
		5	IDLE auto			0: Allow IDLE_sel control in Bit 4 1: Automatic IDLE detect
		4	IDLE select			0: Output is muted (electrical idle) 1: Output is ON (SD is disabled)
		3:2	Reserved			Set bits to 0.
		1	RATE auto			0: Allow RATE_sel control in Bit 0 1: Automatic RATE detect
		0	RATE select			0: 2.5 Gbps 1: Gbps
0x41	CH7 - CHA3 EQ Control	7:6	Reserved	R/W	0x20	Set bits to 0.
		5:0	CH7 IA3 EQ			IA3 EQ Control - total of 24 levels (3 gain stages with 8 settings) [5]: Enable EQ [4:3]: Gain Stage Control [2:0]: Boost Level Control Pin [EQ0 EQ1] = Register [EN] [GST] [BST] = Hex Value FF = 100000 = 20'h = Bypass (Default) 11 = 101010 = 2A'h 00 = 110000 = 30'h F0 = 110010 = 32'h 10 = 111001 = 39'h F1 = 110101 = 35'h 01 = 110111 = 37'h 0F = 111011 = 3B'h 1F = 111101 = 3D'h
0x42	CH7 - CHA3 VOD Control	7	Reserved	R/W	0x03	Set bit to 0.
		6:0	CH7 OA3 VOD			OA3 VOD Control 03'h = 600 mV (Default) 07'h = 800 mV 0F'h = 1000 mV 1F'h = 1200 mV 3F'h = 1400 mV
0x43	CH7 - CHA3 DE Control	7:0	CH7 OA3 DEM	R/W	0x03	OA3 DEM Control [7]: DEM TYPE (Compatibility = 0 / Enhanced = 1) [6:0]: DEM Level Control Pin [DEM1 DEM0] = Register [TYPE] [Level Control] = Hex Value 00 = 0000001 = 01'h = 0.0 dB 01 = 0000011 = 03'h = -3.5 dB 10 = 0000101 = 05'h = -6.0 dB 0F = 10001000 = 88'h = -6.0 dB 01 = 10010000 = 90'h = -9.0 dB 1F = 10100000 = A0'h = -12.0 dB F0 = 10010000 = 90'h = -9.0 dB F1 = 10100000 = A0'h = -12.0 dB FF = 11000000 = C0'h = Reserved
0x44	CH7 - CHA3 IDLE Threshold	7:4	Reserved	R/W	0x00	Set bits to 0.
		3:0	IDLE threshold			De-assert = [3:2], assert = [1:0] 00 = 110 mV, 70 mV (Default) 01 = 150 mV, 110 mV 10 = 170 mV, 130 mV 11 = 190 mV, 150 mV

## Applications Information

### GENERAL RECOMMENDATIONS

The DS50PCI401 is a high performance circuit capable of delivering excellent performance. Careful attention must be paid to the details associated with high-speed design as well as providing a clean power supply. Refer to the information below and the latest version of the LVDS Owner's Manual for more detailed information on high speed design tips to address signal integrity design issues.

### PCB LAYOUT CONSIDERATIONS FOR DIFFERENTIAL PAIRS

The CML inputs and LPDS outputs have been optimized to work with interconnects using a controlled differential

impedance of  $100\Omega$ . It is preferable to route differential lines exclusively on one layer of the board, particularly for the input traces. The use of vias should be avoided if possible. If vias must be used, they should be used sparingly and must be placed symmetrically for each side of a given differential pair. Whenever differential vias are used the layout must also provide for a low inductance path for the return currents as well. Route the differential signals away from other signals and noise sources on the printed circuit board. See AN-1187 for additional information on LLP packages.

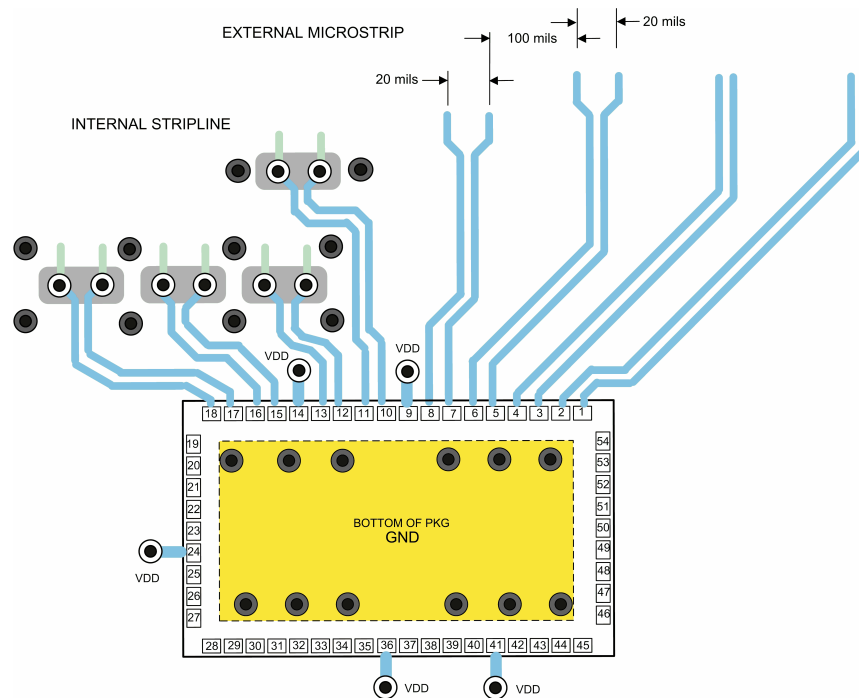

30060410

FIGURE 8. Typical Routing Options

The graphic shown above depicts different transmission line topologies which can be used in various combinations to achieve the optimal system performance. Impedance discontinuities at the differential via can be minimized or eliminated by increasing the swell around each hole and providing for a low inductance return current path. When the via structure is associated with thick backplane PCB, further optimization such as back drilling is often used to reduce the detrimental high frequency effects of stubs on the signal path.

### POWER SUPPLY BYPASSING

Two approaches are recommended to ensure that the DS50PCI401 is provided with an adequate power supply. First, the supply (VDD) and ground (GND) pins should be

connected to power planes routed on adjacent layers of the printed circuit board. The layer thickness of the dielectric should be minimized so that the  $V_{DD}$  and GND planes create a low inductance supply with distributed capacitance. Second, careful attention to supply bypassing through the proper use of bypass capacitors is required. A  $0.01\ \mu\text{F}$  bypass capacitor should be connected to each  $V_{DD}$  pin such that the capacitor is placed as close as possible to the DS50PCI401. Smaller body size capacitors can help facilitate proper component placement. Additionally, three capacitors with capacitance in the range of  $2.2\ \mu\text{F}$  to  $10\ \mu\text{F}$  should be incorporated in the power supply bypassing design as well. These capacitors can be either tantalum or an ultra-low ESR ceramic.

# Typical Performance Eye Diagrams and Curves

www.DataSheet4U.com

## DS50PCI401 Return Loss

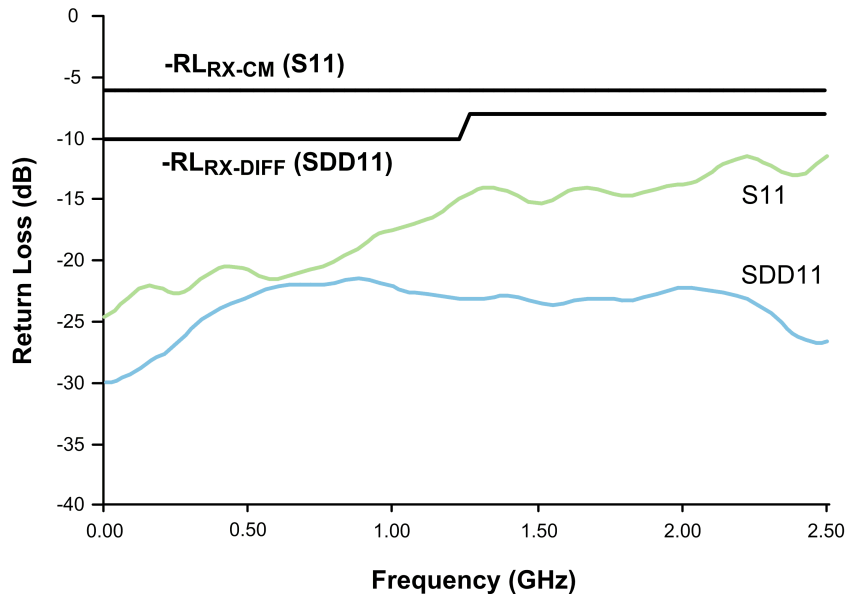

30060450

FIGURE 9. Receiver Return Loss Mask for 5.0 Gbps

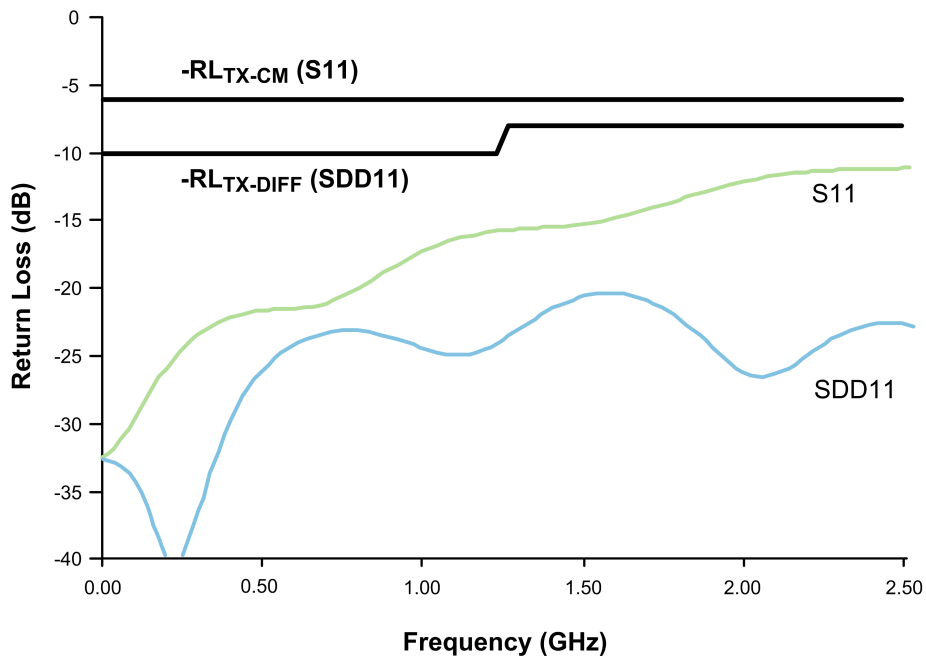

30060451

FIGURE 10. Transmitter Return Loss Mask for 5.0 Gbps

# Physical Dimensions inches (millimeters) unless otherwise noted

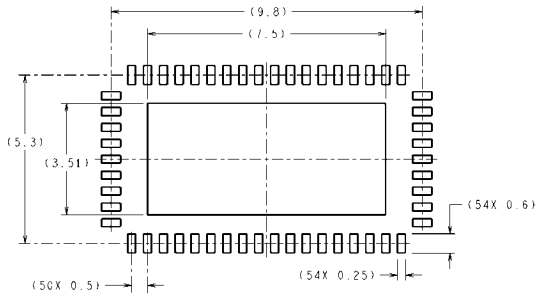

RECOMMENDED LAND PATTERN

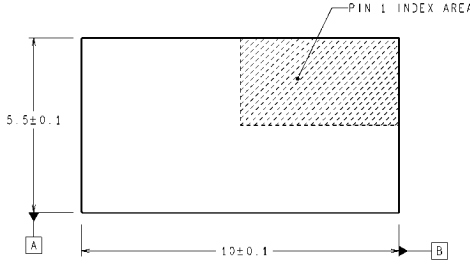

DIMENSIONS ARE IN MILLIMETERS  
DIMENSIONS IN ( ) FOR REFERENCE ONLY

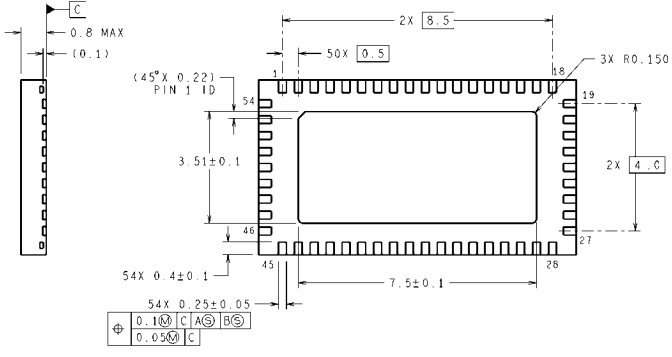
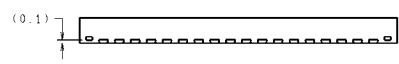

Φ	0.1	C	A	B
	0.05	C		

SQA54A (Rev B)

**Order Number DS50PCI401SQ (Tape and Reel 2000 units)**  
**Order Number DS50PCI401SQE (Tape and Reel 250 units)**  
**NS Package Number SQA54A**  
**(See AN-1187 for PCB Design and Assembly Recommendations)**

# Notes

## Notes

For more National Semiconductor product information and proven design tools, visit the following Web sites at:

Products		Design Support	
Amplifiers	<a href="http://www.national.com/amplifiers">www.national.com/amplifiers</a>	WEBENCH® Tools	<a href="http://www.national.com/webench">www.national.com/webench</a>
Audio	<a href="http://www.national.com/audio">www.national.com/audio</a>	App Notes	<a href="http://www.national.com/appnotes">www.national.com/appnotes</a>
Clock and Timing	<a href="http://www.national.com/timing">www.national.com/timing</a>	Reference Designs	<a href="http://www.national.com/refdesigns">www.national.com/refdesigns</a>
Data Converters	<a href="http://www.national.com/adc">www.national.com/adc</a>	Samples	<a href="http://www.national.com/samples">www.national.com/samples</a>
Interface	<a href="http://www.national.com/interface">www.national.com/interface</a>	Eval Boards	<a href="http://www.national.com/evalboards">www.national.com/evalboards</a>
LVDS	<a href="http://www.national.com/lvds">www.national.com/lvds</a>	Packaging	<a href="http://www.national.com/packaging">www.national.com/packaging</a>
Power Management	<a href="http://www.national.com/power">www.national.com/power</a>	Green Compliance	<a href="http://www.national.com/quality/green">www.national.com/quality/green</a>
Switching Regulators	<a href="http://www.national.com/switchers">www.national.com/switchers</a>	Distributors	<a href="http://www.national.com/contacts">www.national.com/contacts</a>
LDOs	<a href="http://www.national.com/ldo">www.national.com/ldo</a>	Quality and Reliability	<a href="http://www.national.com/quality">www.national.com/quality</a>
LED Lighting	<a href="http://www.national.com/led">www.national.com/led</a>	Feedback/Support	<a href="http://www.national.com/feedback">www.national.com/feedback</a>
Voltage Reference	<a href="http://www.national.com/vref">www.national.com/vref</a>	Design Made Easy	<a href="http://www.national.com/easy">www.national.com/easy</a>
PowerWise® Solutions	<a href="http://www.national.com/powerwise">www.national.com/powerwise</a>	Solutions	<a href="http://www.national.com/solutions">www.national.com/solutions</a>
Serial Digital Interface (SDI)	<a href="http://www.national.com/sdi">www.national.com/sdi</a>	Mil/Aero	<a href="http://www.national.com/milaero">www.national.com/milaero</a>
Temperature Sensors	<a href="http://www.national.com/tempensors">www.national.com/tempensors</a>	SolarMagic™	<a href="http://www.national.com/solarmagic">www.national.com/solarmagic</a>
Wireless (PLL/VCO)	<a href="http://www.national.com/wireless">www.national.com/wireless</a>	PowerWise® Design University	<a href="http://www.national.com/training">www.national.com/training</a>

THE CONTENTS OF THIS DOCUMENT ARE PROVIDED IN CONNECTION WITH NATIONAL SEMICONDUCTOR CORPORATION ("NATIONAL") PRODUCTS. NATIONAL MAKES NO REPRESENTATIONS OR WARRANTIES WITH RESPECT TO THE ACCURACY OR COMPLETENESS OF THE CONTENTS OF THIS PUBLICATION AND RESERVES THE RIGHT TO MAKE CHANGES TO SPECIFICATIONS AND PRODUCT DESCRIPTIONS AT ANY TIME WITHOUT NOTICE. NO LICENSE, WHETHER EXPRESS, IMPLIED, ARISING BY ESTOPPEL OR OTHERWISE, TO ANY INTELLECTUAL PROPERTY RIGHTS IS GRANTED BY THIS DOCUMENT.

TESTING AND OTHER QUALITY CONTROLS ARE USED TO THE EXTENT NATIONAL DEEMS NECESSARY TO SUPPORT NATIONAL'S PRODUCT WARRANTY. EXCEPT WHERE MANDATED BY GOVERNMENT REQUIREMENTS, TESTING OF ALL PARAMETERS OF EACH PRODUCT IS NOT NECESSARILY PERFORMED. NATIONAL ASSUMES NO LIABILITY FOR APPLICATIONS ASSISTANCE OR BUYER PRODUCT DESIGN. BUYERS ARE RESPONSIBLE FOR THEIR PRODUCTS AND APPLICATIONS USING NATIONAL COMPONENTS. PRIOR TO USING OR DISTRIBUTING ANY PRODUCTS THAT INCLUDE NATIONAL COMPONENTS, BUYERS SHOULD PROVIDE ADEQUATE DESIGN, TESTING AND OPERATING SAFEGUARDS.

EXCEPT AS PROVIDED IN NATIONAL'S TERMS AND CONDITIONS OF SALE FOR SUCH PRODUCTS, NATIONAL ASSUMES NO LIABILITY WHATSOEVER, AND NATIONAL DISCLAIMS ANY EXPRESS OR IMPLIED WARRANTY RELATING TO THE SALE AND/OR USE OF NATIONAL PRODUCTS INCLUDING LIABILITY OR WARRANTIES RELATING TO FITNESS FOR A PARTICULAR PURPOSE, MERCHANTABILITY, OR INFRINGEMENT OF ANY PATENT, COPYRIGHT OR OTHER INTELLECTUAL PROPERTY RIGHT.

#### LIFE SUPPORT POLICY

**NATIONAL'S PRODUCTS ARE NOT AUTHORIZED FOR USE AS CRITICAL COMPONENTS IN LIFE SUPPORT DEVICES OR SYSTEMS WITHOUT THE EXPRESS PRIOR WRITTEN APPROVAL OF THE CHIEF EXECUTIVE OFFICER AND GENERAL COUNSEL OF NATIONAL SEMICONDUCTOR CORPORATION.** As used herein:

Life support devices or systems are devices which (a) are intended for surgical implant into the body, or (b) support or sustain life and whose failure to perform when properly used in accordance with instructions for use provided in the labeling can be reasonably expected to result in a significant injury to the user. A critical component is any component in a life support device or system whose failure to perform can be reasonably expected to cause the failure of the life support device or system or to affect its safety or effectiveness.

National Semiconductor and the National Semiconductor logo are registered trademarks of National Semiconductor Corporation. All other brand or product names may be trademarks or registered trademarks of their respective holders.

Copyright© 2009 National Semiconductor Corporation

For the most current product information visit us at [www.national.com](http://www.national.com)



**National Semiconductor Americas Technical Support Center**  
Email: [support@nsc.com](mailto:support@nsc.com)  
Tel: 1-800-272-9959

**National Semiconductor Europe Technical Support Center**  
Email: [europe.support@nsc.com](mailto:europe.support@nsc.com)

**National Semiconductor Asia Pacific Technical Support Center**  
Email: [ap.support@nsc.com](mailto:ap.support@nsc.com)

**National Semiconductor Japan Technical Support Center**  
Email: [jpn.feedback@nsc.com](mailto:jpn.feedback@nsc.com)