

30V, 400mA Low Dropout Voltage Linear Regulator

General Description

The DS8301A series are a group of low-dropout (LDO) voltage regulators offering the benefits of wide input voltage range, low dropout voltage, low power consumption, and miniaturized packaging.

Quiescent current of only 2.2 μ A makes these devices ideal for powering the battery-powered, always-on systems that require very little idle-state power dissipation to a longer service life. There is a shutdown mode by pulling the EN pin low. The shutdown current in this mode goes down to only 10nA (typical).

The DS8301A series of linear regulators are stable with the ceramic output capacitor over its wide input range from 2V to 30V and the entire range of output load current (0mA to 400mA).

Applications

- Portable, Battery Powered Equipment
- Low Power Microcontrollers
- Laptop, Palmtops and PDAs
- Wireless Communication Equipment
- Audio/Video Equipment
- Car Navigation Systems
- Industrial Controls
- Weighting Scales
- Meters
- Home Automation

Features

- 2.2 μ A Ground Current at no Load
- \pm 2% Output Accuracy
- 400mA Output Current
- 10nA Disable Current
- Wide Operating Input Voltage Range: 2V to 30V
- Dropout Voltage: 0.15V at 100mA / V_{OUT} 5V
- Support Fixed Output Voltage 1.2V, 1.8V, 3.3V, 5V, 9V, 12V
- Adjustable Output Voltage Available by Specific Application
- Stable with Ceramic or Tantalum Capacitor
- Current Limit Protection
- Over-Temperature Protection
- SOT-23-5 Package Available

Pin Configurations

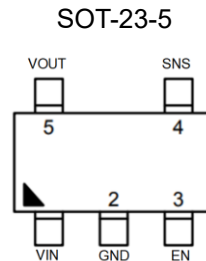

Ordering InformationDS8301A-**AA****BB**

Designator	Description	Symbol	Description
AA	Output Voltage	12	$V_{OUT} = 1.2V$
	
	
		99	$V_{OUT} = 9.9V$
		A1	$V_{OUT} = 12V$
BB	Package type	S5	SOT-23-5

Special Request: Any Voltage between 1.2V and 12V under specific business agreement

Description of Functional Pins

Pin No	Pin Name	Pin Function
1	VIN	Input of Supply Voltage.
2	GND	Ground
3	EN	Enable Control Input.
4	SNS	Sense of Output Voltage.
5	VOUT	Output of the Regulator

Typical Application Circuits

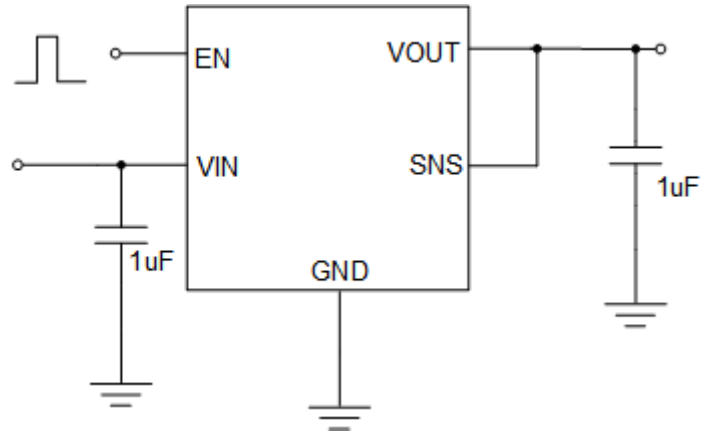

Figure 1: Application circuit of Fixed V_{OUT} LDO with enable and sense functions

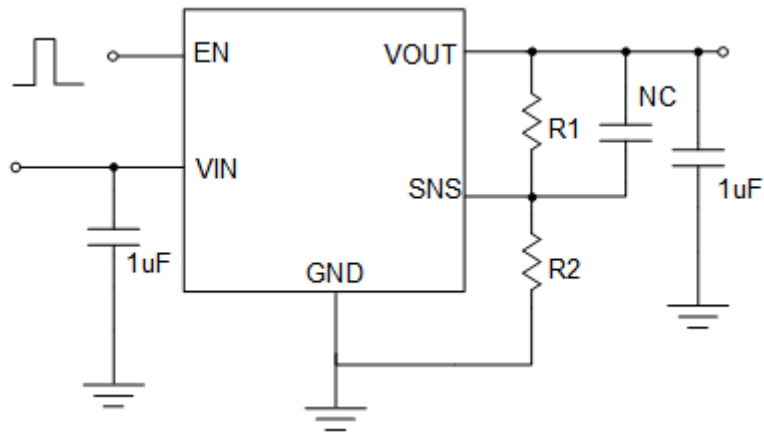
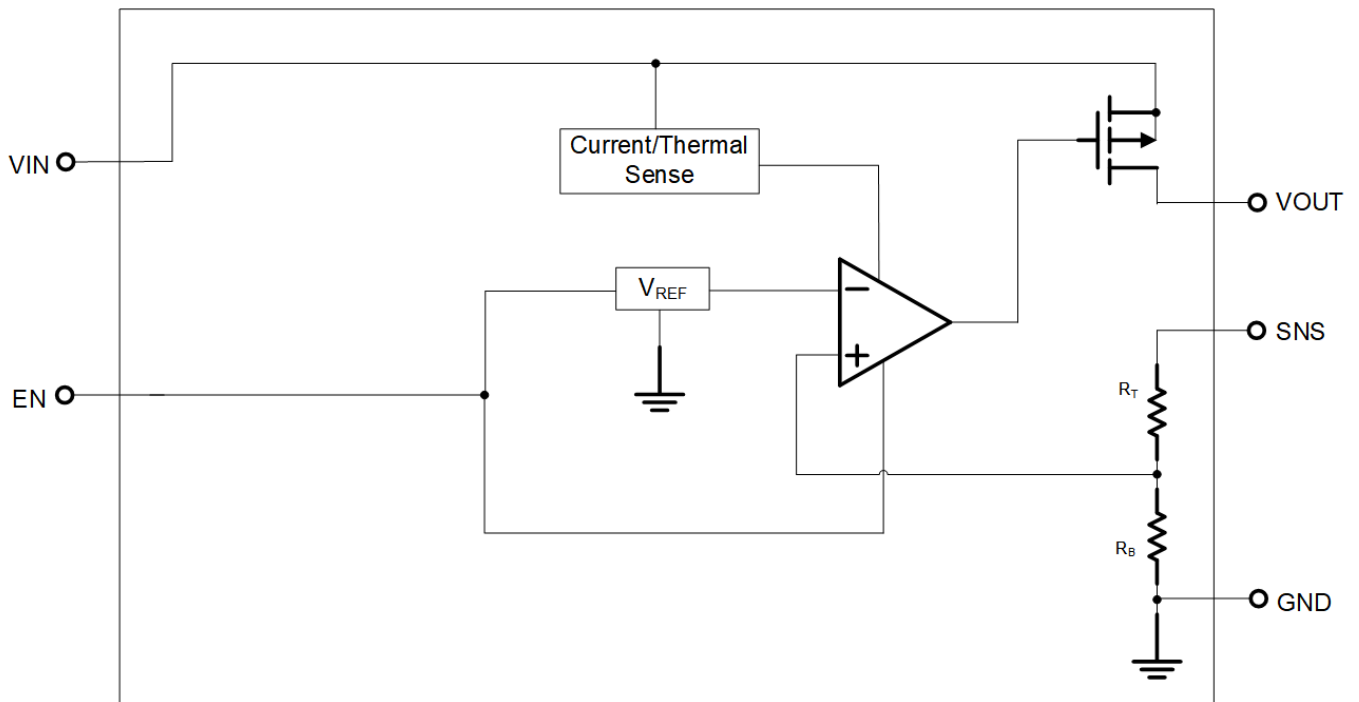

Figure 2: Adjustable output voltage LDO application circuit by DS8301A

Function Block Diagram



Absolute Maximum Ratings (Note 1)

VIN, EN to GND	-0.3V to 36V
SNS to GND	-0.3V to 6V
VOUT to GND	
DS8301A-A1, DS8301A-90	-0.3V to 14V
DS8301A-12, DS8301A-18, DS8301A-33, DS8301A-50	-0.3V to 6V
VOUT to VIN	-36V to 0.3V
Package Thermal Resistance (Note 2)	
SOT-23-5, θ_{JA}	200 °C /W
Lead Temperature (Soldering, 10 sec.)	260 °C
Junction Temperature	150 °C
Storage Temperature Range	-60 °C to 150 °C
ESD Susceptibility	
HBM	2KV
MM	200V

Recommended Operating Conditions

Input Voltage VIN	2.0V to 30V
Junction Temperature Range	-40 °C to 125 °C
Ambient Temperature Range	-40 °C to 85 °C

Electrical Characteristics

($V_{IN} = 15V$, $V_{EN} = 5V$, $T_A = 25^\circ C$ unless otherwise specified)

Parameter	Symbol	Test Conditions	Min	Typ	Max	Unit
Supply Voltage	V_{IN}		2	--	30	V
DC Output Voltage Accuracy		$I_{LOAD} = 0.1mA$	-2		2	%
Dropout Voltage ($I_{LOAD} = 100mA$)	V_{DROP}	$V_{OUT} \geq 5V$	--	0.15		V
	$V_{DROP_3.3V}$	$V_{OUT} = 3.3V$		0.15		
	$V_{DROP_1.8V}$	$V_{OUT} = 1.8V$		0.25		
Dropout Voltage ($V_{OUT} = 1.8V$)	$V_{DROP_1.8V}$	$I_{LOAD} = 200mA$	--	0.47		V
		$I_{LOAD} = 300mA$		0.69		
		$I_{LOAD} = 400mA$		0.93		
Ground Current ($I_{LOAD} = 0mA$)	I_Q	$V_{OUT} \leq 5V$		2.2		μA
	I_{QH}	$5V < V_{OUT} \leq 12V$		4.2		
Shutdown Ground Current	I_{SD}	$V_{EN} = 0V$, $V_{OUT} = 0V$		0.01	0.5	μA
V_{OUT} Shutdown Leakage Current	I_{LEAK}			0.01	0.5	μA
SNS Input Current	I_{SNS}	$SNS = V_{OUT}$ $V_{OUT} \leq 5V$		0.9		μA
Enable Threshold Voltage	V_{IH}	EN Rising			2	V
	V_{IL}	EN Falling	0.6			
EN Input Current	I_{EN}	$V_{EN} = 30V$		10	100	nA
Line Regulation	Δ_{LINE}	$I_{LOAD} = 1mA$, $5 \leq V_{IN} \leq 30V$	--	0.3		%
Load Regulation	Δ_{LOAD}	$1mA \leq I_{LOAD} \leq 0.2A$		0.1		%
Output Current Limit	I_{LIM}	$V_{OUT} = 0$	401	600		mA
Power Supply Rejection Ratio	PSRR	$V_{OUT} = 5V$, $I_{LOAD} = 1mA$, $V_{IN} = 12V$, $f = 100Hz$		70		dB
Thermal Shutdown Temperature	T_{SD}	$I_{LOAD} = 10mA$	--	160	--	$^\circ C$
Thermal Shutdown Hysteresis	ΔT_{SD}				15	

Note 1. Stresses beyond those listed “Absolute Maximum Ratings” may cause permanent damage to the device. These are stress ratings only, and functional operation of the device at these or any other conditions beyond those indicated in the operational sections of the specifications is not implied. Exposure to absolute maximum rating conditions may affect device reliability.

Note 2. θ_{JA} is measured at $T_A = 25^\circ C$ on a DS-Tech EVB board.

Typical Characteristics

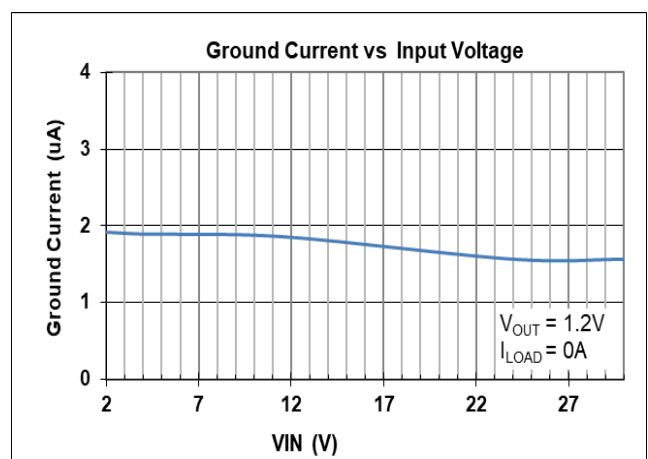
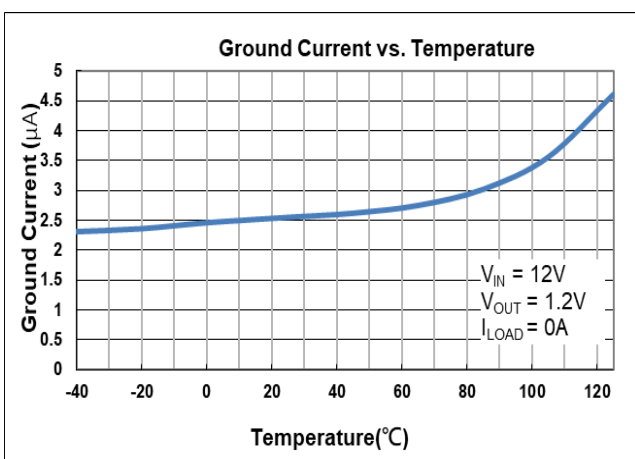
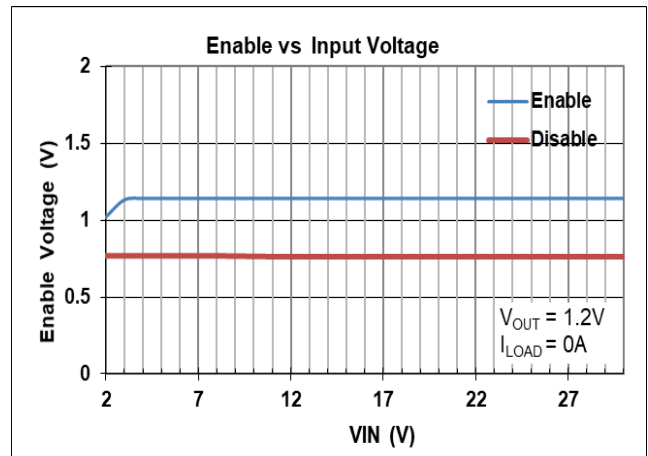
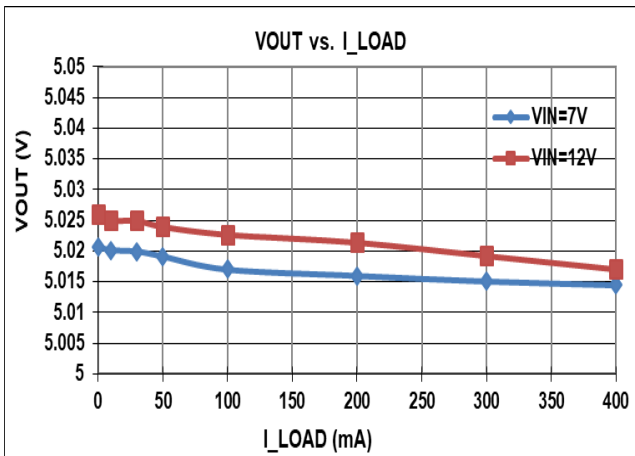
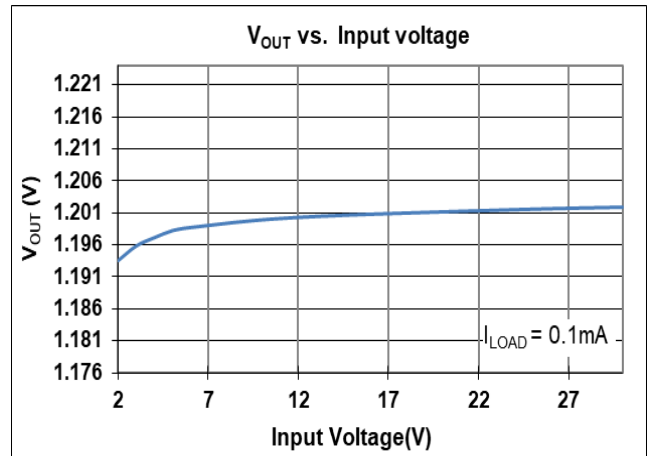
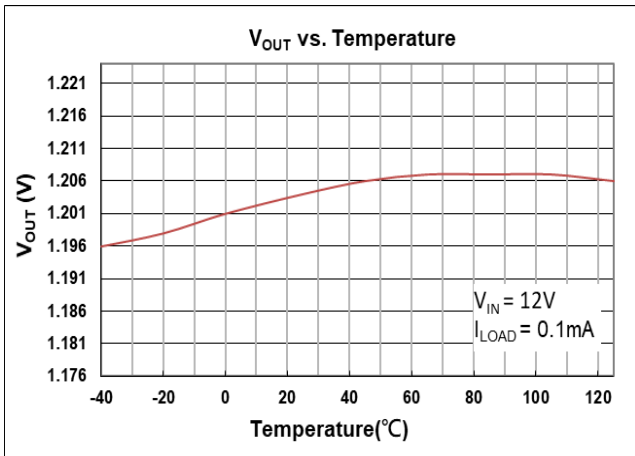

Load Transient Response

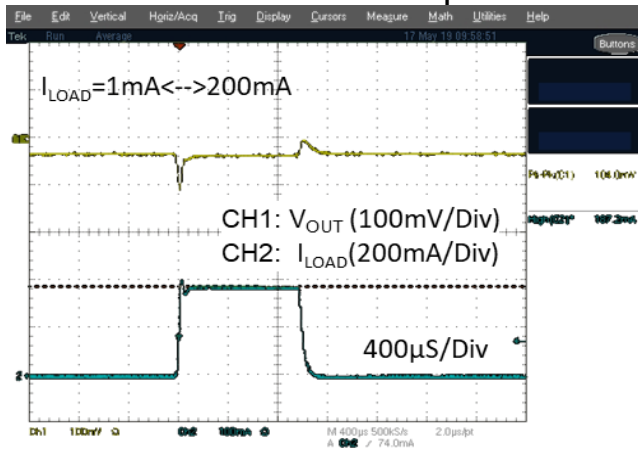

Line Transient Response

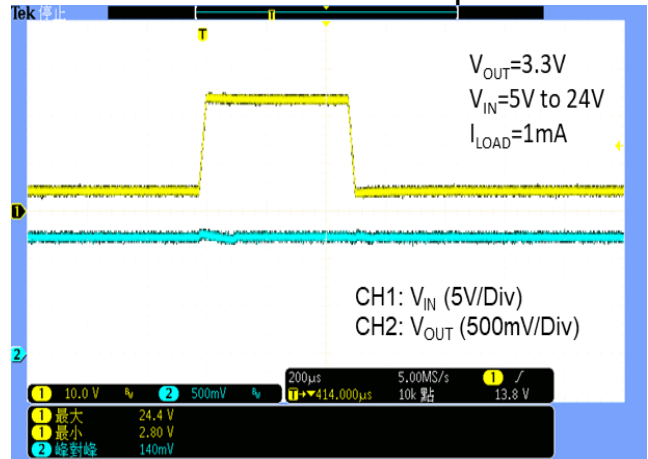

V_{OUT} Turn on by V_{IN} Quick Power Up

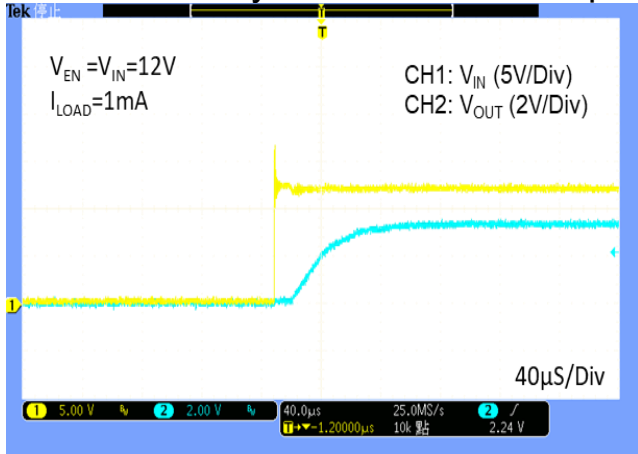

V_{OUT} Turn Off by EN

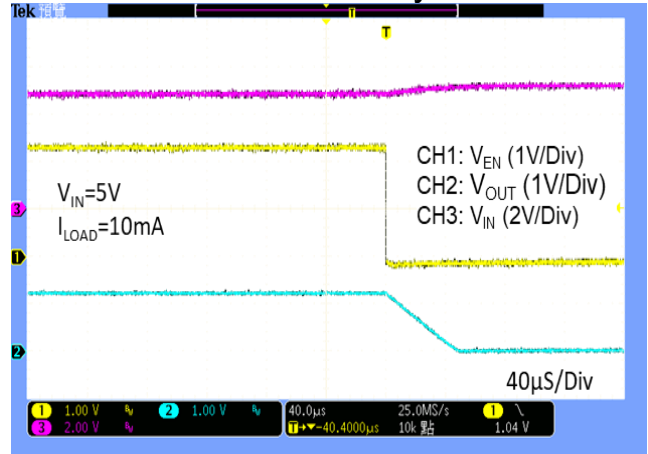

V_{OUT} Turn On by EN

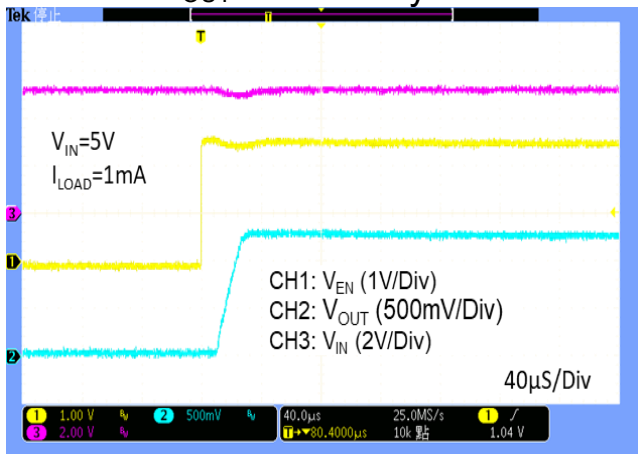

Input and Output Capacitor Requirements

The external input and output capacitors of DS8301A series must be properly selected for stability and performance. Use a 1μF or larger input capacitor and place it close to the IC's VIN and GND pins. Any output capacitor meeting the minimum 1mΩ ESR (Equivalent Series Resistance) and effective capacitance between 1μF and 22μF requirement may be used. Place the output capacitor close to the IC's VOUT and GND pins. Increasing capacitance and decreasing ESR can improve the circuit's PSRR and line transient response.

Current Limit

The DS8301A series contain the current limiter of output power transistor, which monitors and controls the transistor, limiting the output current to 300mA (typical). The output can be shorted to ground indefinitely without damaging the part.

Dropout Voltage

The DS8301A series use a PMOS pass transistor to achieve low dropout. When (VIN – VOUT) is less than the dropout voltage (V_{DROP}), the PMOS pass device is in the linear region of operation and the input-to-output resistance is the R_{DS(ON)} of the PMOS pass element. V_{DROP} scales approximately with the output current because the PMOS device behaves as a resistor in dropout condition.

As any linear regulator, PSRR and transient response are degraded as (VIN – VOUT) approaches dropout condition.

Adjustable Output Voltage Application

The DS8301A with SNS pin also can work as an adjustable output voltage LDO. Figure 2 gives the connections for the adjustable output voltage application. The resistor divider from VOUT to SNS sets the output voltage when in regulation.

The voltage on the SNS pin sets the output voltage and is determined by the values of R1 and R2. In order to keep a good temperature coefficient of output voltage, the values of R1 and R2 should be selected carefully to ignore the temperature effect of input current at the SNS pin. A current greater than 50μA in the resistor divider is recommended to meet the above requirement. The adjustable output voltage can be calculated using the formula given in equation 1:

$$V_{OUT} = \frac{R1+R2}{R2} \times V_{SNS} \quad (1)$$

where V_{SNS} is determined by the output voltage selections in the ordering information of DS8301A-XX. The maximum adjustable output voltage is 12V. Generally, to maximize the available adjustable output voltage range, DS8301A-18S5 is recommended (V_{SNS} is 1.8V in formula 1 now).

The minimum recommended 50μA in the resistor divider makes the application no longer a 2.2μA low quiescent LDO.

OTP (Over Temperature Protection)

The over temperature protection function of DS8301A series will turn off the P-MOSFET when the junction temperature exceeds 160°C (typ.). Once the junction temperature cools down by approximately 15°C, the regulator will automatically resume operation.

Thermal Application

For continuous operation, do not exceed the absolute maximum junction temperature. The maximum power dissipation depends on the thermal resistance of the IC package, PCB layout, rate of surrounding airflow, and difference between junction and ambient temperature. The maximum power dissipation can be calculated as

below:

$T_A=25^{\circ}\text{C}$, DS-Tech PCB,

The max PD (Max)= $(125^{\circ}\text{C} - 25^{\circ}\text{C}) / (200^{\circ}\text{C/W}) = 0.5\text{W}$
for SOT-23-5 packages.

Power dissipation (PD) is equal to the product of the output current and the voltage drop across the output pass element, as shown in the equation below:

$$\text{PD} = (\text{VIN} - \text{VOUT}) \times \text{IOUT}$$

Layout Consideration

By placing input and output capacitors on the same side of the PCB as the LDO, and placing them as close as is practical to the package can achieve the best performance. The ground connections for input and output capacitors must be back to the DS8301A ground pin using as wide and as short of a copper trace as is practical.

Connections using long trace lengths, narrow trace widths, and/or connections through via must be avoided. These add parasitic inductances and resistance that results in worse performance especially during transient conditions.

Package Information:

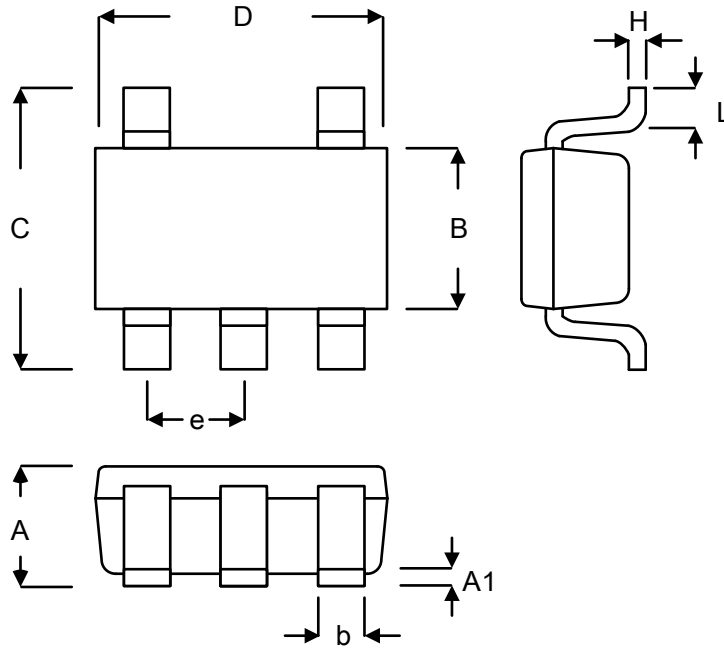

Symbol	Millimeters		Inches	
	Min.	Max.	Min.	Max.
A	0.889	1.295	0.035	0.051
A1	0.000	0.152	0.000	0.006
B	1.397	1.803	0.055	0.071
b	0.250	0.560	0.010	0.022
C	2.591	2.997	0.102	0.118
D	2.692	3.099	0.106	0.122
e	0.838	1.041	0.033	0.041
H	0.080	0.254	0.003	0.010
L	0.300	0.610	0.012	0.024

SOT-23-5L