

APPROVAL SHEET

(承認仕様書)

CUSTOMER	
I T E M	NTC THERMISTOR
M O D E L	DSC-20D-22 MSSB
APPLICATION	
REMARK	© type

D S C ELECTRONICS CO., LTD.

9-2, Suyoung- Ri, Bongdam-Eup, Hwasung- City, KOREA

TEL : (031) 296-7093

FAX : (031) 296-7096

SPECIFICATION FOR NTC THERMISTOR

IN-RUSH CURRENT LIMITER : 22 PIE

1. APPLICATIONS

- 1) INRUSH CURRENT LIMITING IN PERIPHERAL COMMUNICATION EQUIPMENT, MONITORS, PCs, SMPS.
- 2) SOFT-START MOTORS, e.g. IN VACUUM CLEANERS
- 3) CIRCUIT APPLICATIONS REQUIRING HIGH CONTINUOUS CURRENTS
- 4) USEABLE IN SERIES CONNECTION UP TO 250 Vrms

2. FEATURES

- 1) HIGH RELIABILITY AND MINIMIZED AGE DRIFT, LOW-COST AND WIDE APPLICATIONS
- 2) BLACK SILICONE OR EPOXY COATED THERMISTOR DISK
- 3) STRAIGHT OR IN/OUT KINKED OR CUTTED LEADS OF TINNED, NICKEL PLATED COPPER WIRE
- 4) USEABLE IN SERIES CONNECTIONS UP TO MAX. 260Vrms (STEADY STATE 240Vrms)
- 5) AVAILABLE ON TAPE
- 6) RESISTANCE TOLERANCE $< \pm 20\%$ AVAILABLE UPON REQUEST

3 DIMENSION

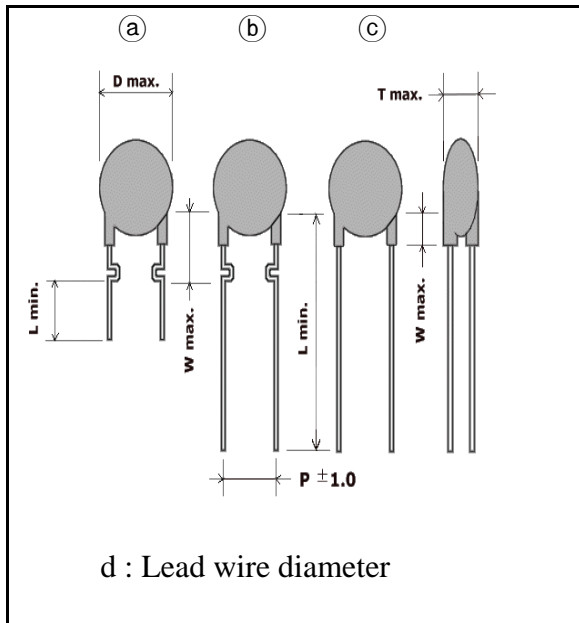

(UNIT : mm)

	(a)	(b)	(c)
D (MAX.)	23.0	23.0	23.0
T (MAX.)	6	6	6
P	10.0	10.0	10.0
W (MAX.)	8	8	6
L (MIN.)	6 ± 1.0	25	25
d	$\phi 1.0$	$\phi 1.0$	$\phi 1.0$
WIRE FORM	F/C	F	S

4. ELECTRICAL CHARACTERISTICS

- 1) ZERO POWER RESISTANCE AT 25°C (Ohms) :
- 2) MAX STEADY STATE CURRENT (Amps) :
- 3) THERMAL DISSIPATION CONSTANT (mW/°C) : REFERENCE No. 5
- 4) THERMAL TIME CONSTANT (sec) :
- 5) OPERATING TEMPERATURE (°C) :
- 6) B VALUE (25/85°C) :

SPECIFICATION FOR NTC THERMISTOR

5. SPECIFICATIONS OF SIMILAR SIZE

TYPE No.	NORMAL RESISTANCE AT 25℃ (ohms/Ω)	MAX. STEADY STATE CURRENT (amps/A)	THERMAL DISSIPATION CONSTANT (mW/℃)	THERMAL TIME CONSTANT (sec)	NORMAL B CONSTANT (25/85℃,K)
DSC - 0.5D - 22	0.5	10.0	23	100	2950±5%
DSC - 1D - 22	1	10.0	23	100	2950
DSC - 2.5D - 22	2.5	9.0	24	100	3000
DSC - 3D - 22	3	9.0	24	100	3100
DSC - 5D - 22	5	8.0	25	95	3150
DSC - 6D - 22	6	7.5	25	95	3150
DSC - 8D - 22	8	7.0	25	95	3150
DSC - 10D - 22	10	6.5	29	95	3150
DSC - 16D - 22	16	6.0	28	100	3200
DSC - 20D - 22	20	5.0	28	105	3200
DSC - 30D - 22	30	5.0	28	115	3300

※ Resistance tolerance : ±10, 15, 20%

※ Operating temperature : - 40 ~ +180℃

6. MATERIAL LIST

ITEM	MATERIAL	DESCRIPTION	POSITION	REMARK
RAW MATERIAL	Mn3O4	99.9%	≒44.00	
	Co3O4	99.9%	≒30.00	
	NiO	99.9%	≒15.00	
	CuO	99.9%	≒11.00	
ADDITION	P.V.A LUBRICANT	PVA-205C LU-6418		
SUB MATERIAL	POWDER Ag PASTE LEAD WIRE G-PAPER TAPE SOLDER BAR COAT. EPOXY COAT. MARKING	A-21 CON COAT. 0.8 pie 500M 6×400M Sn×Ag AF490 CP-903BK U.V. INK		VARIABLE
PACKAGE	POLY BAG. INNER BOX PACKING	175×260 140×180×40t 445×305×215H		BULK : 200/500EA TAPING : 1,000EA

7.TERMINOLGY AND GENERAL SPECIFICATIONS

TECHNICAL TERMS	DESCRIPTIONS	SPEC.
OPERATING TEMP.	OPERATING TEMPERATURE RANGE WITHOUT DERATING	-40 TO 180°C
STORAGE TEMP	STORAGE TEMPERATURE RANGE WITHOUT CURRENT APPLIED.	-30 TO 80°C
ZERO POWER RESISTANCE	THE ZERO POWER RESISTANCE IS THE RESISTANCE OF A THERMISTOR AT 25°C AMBIENT TEMPERATURE.	SEE RATING TABLE
B VALUE	<p>B VALUE CAN BE DERIVED BY MEASURING THE RESISTANCE AT 25°C (R1) AND 85°C (R2) AND CALCULATING BY FOLLOWING FORMULA.</p> $B = \frac{\ln(R2/R1)}{1/(273.15+T2) - 1/(273.15+T1)}$	SEE RATING TABLE
MAX. STEADY STATE CURRENT	THE MAX STEADY STATE CURRENT IS THE MAXIMUM ALLOWABLE CURRENT AT LOADING TO MAX OPERATING TEMPERATURE IN 25°C AMBIENT.	SEE RATING TABLE
THERMAL DISSIPATION CONSTANT	THE DISSIPATION CONSTANT MEANS THE AMOUNT OF POWER REQUIRED TO RAISE THE APPLIED TEMPERATURE TO THE THERMISTOR IN STATIONARY STATE FOR 1°C.	SEE RATING TABLE
THERMAL TIME CONSTANT	<p>THE TIME CONSTANT IS DEFINED AS RELATIONSHIP BETWEEN THE THERMAL CAPACITY AND DISSIPATION CONSTANT. IT IS MEASURED AS TIME IN SECONDS WHICH IS NEEDED FOR THERMISTOR TEMPERATURE CHANGE OF 63.2% DIFFERENCE BETWEEN INITIAL AND FINAL THERMISTOR TEMPERATURE.</p>	SEE RATING TABLE

D S C

TECHNICAL TERMS	DESCRIPTIONS	SPEC.
LOAD LIFE	THERMISTOR SHALL BE STORED FOR 1,000± 12HOURS AT 25 °C ± 2 °C WITH THE MAXIMUM RATED APPLICABLE STEADY STATE CURRENT APPLIED. AFTER THE STORAGE PERIOD. TO AND STABILIZED AT ROOM TEMP.	MAXIMUM RESISTANCE CHANGE : ± 15% OF INITIAL
TEMPERATURE CYCLE	THERMISTOR SHALL BE SUBJECTED TO THE FOLLOWING 10 CYCLES : AT -40±3 °C FOR 30 MINUTES AND AT +150±2 °C FOR 30 MINUTES. AFTER THE CYCLES. THE THERMISTOR SHALL BE RETURNED TO AND STABILIZED AT ROOM AMBIENT TEMP.	MAXIMUM RESISTANCE CHANGE : ± 15% OF INITIAL, AND THERE SHALL BE NO EVIDENCE OF HARMFUL CORROSION, MECHANICAL
MOISTURE RESISTANCE	THERMISTOR SHALL BE STORED FOR 1,000 ±12 HOURS AT 40±2 °C, 90-95% RH WITH NO CURRENT APPLIED. AFTER THE STORAGE PERIOD THE THERMISTOR SHALL BE RETURNED TO AND STABILIZED AT ROOM TEMP.	MAXIMUM RESISTANCE CHANGE : ± 15% OF INITIAL.
LEAD FULL STRENGTH	AFTER GRADUALLY APPLYING THE 1Kg LOAD AND KEEPING THE UNIT FIXED FOR 10 SECONDS IN THE AXIAL DIRECTION. THE LEAD SHALL BE VISUALLY EXAMINED FOR ANY DAMAGE	NO OUTSTANDING DAMAGE.
SOLDERING HEAT RESISTANCE	THE LEAD WIRE OF THE THERMISTOR SHALL BE DIPPED WITH 4±1mm SPACE OF 300± 5 °C FOR 3 SEC, RETURNED TO AND STABILIZED AT ROOM TEMP.	MAXIMUM RESISTANCE CHANGE : ± 15% OF INITIAL.

D S C

TECHNICAL TERMS	DESCRIPTIONS	SPEC.
SOLDERABILITY	<p>WHEN THE LEAD WIRE OF THERMISTOR WAS DIPPED INTO SOLDER (Sn98:Ag2) BATH of $330 \pm 5^\circ\text{C}$ FOR 3 SECONDS AFTER IMMERSION IN 25% RESIN FLUX. THE SOLDERABILITY RATIO OF LEAD WIRE SURFACE SHOULD BE MORE THAN 95%</p>	<p>MORE THAN 95% SOLDERABILITY</p>
SURGE CURRENT LIFE	<p>THERMISTOR SHALL BE SUBJECTED THE FOLLOWING 2,000 CYCLES.</p> <p>- SURGE CURRENT : MAX STEADY STATE CURRENT.</p> <p>- INTERVAL : 15 SECONDS</p> <p>AFTER THE CYCLES, THE THERMISTOR SHALL BE RETURNED TO.</p>	<p>MAXIMUM RESISTANCE CHANGE : $\pm 15\%$</p>
INSULATION RESISTANCE	<p>THE THERMISTOR SHOULD BE NO CHANGED.</p> <p>AFTER APPLIED THE VOLTAGE OF 1,500 Vac FOR ONE MINUTE BETWEEN THE LEAD WIRE AND THE INSULATION COATED PORTION.</p>	<p>WITHIN $\pm 15\%$ RESISTANCE CHANGE AND NO DAMAGE.</p>
INSULATION RESISTANCE	<p>THE INSULATION RESISTANCE SHOULD BE OVER 500M OHMS WITH 1,000Vdc BETWEEN THE LEAD WIRE AND THE INSULATION COATED PORTION.</p>	<p>WITHIN $\pm 15\%$ RESISTANCE CHANGE AND NO DAMAGE.</p>

MODEL NUMBERING

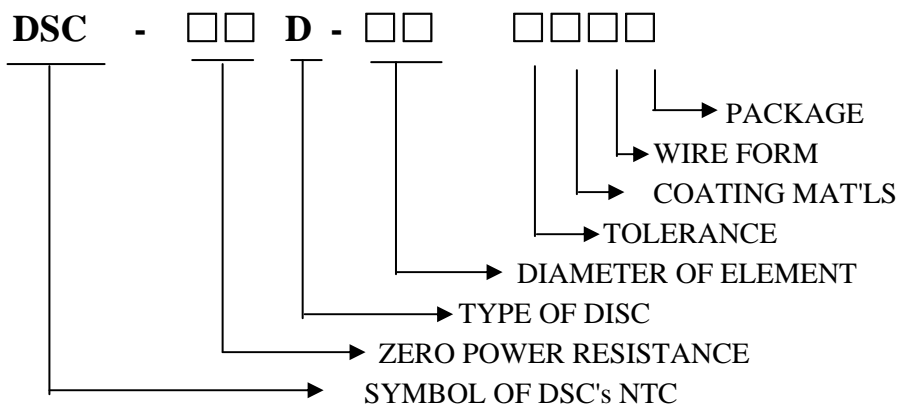

* TOLERANCE K : $\pm 10\%$
 L : $\pm 15\%$
 M : $\pm 20\%$

* COATING MAT'L/WIRE FORM
 E/S : EPOXY/STRAIGHT
 S/S : SILICONE/STRAIGHT
 S/F : SILICONE/FORMING

* PACKAGE T : TAPING
 B : BULK
 C : CUTTING

TYPICAL R-T CURVE FOR DSC SERIES (NTC)

MODEL NO. DSC - 200 - 22
B VALUE 3,200 K

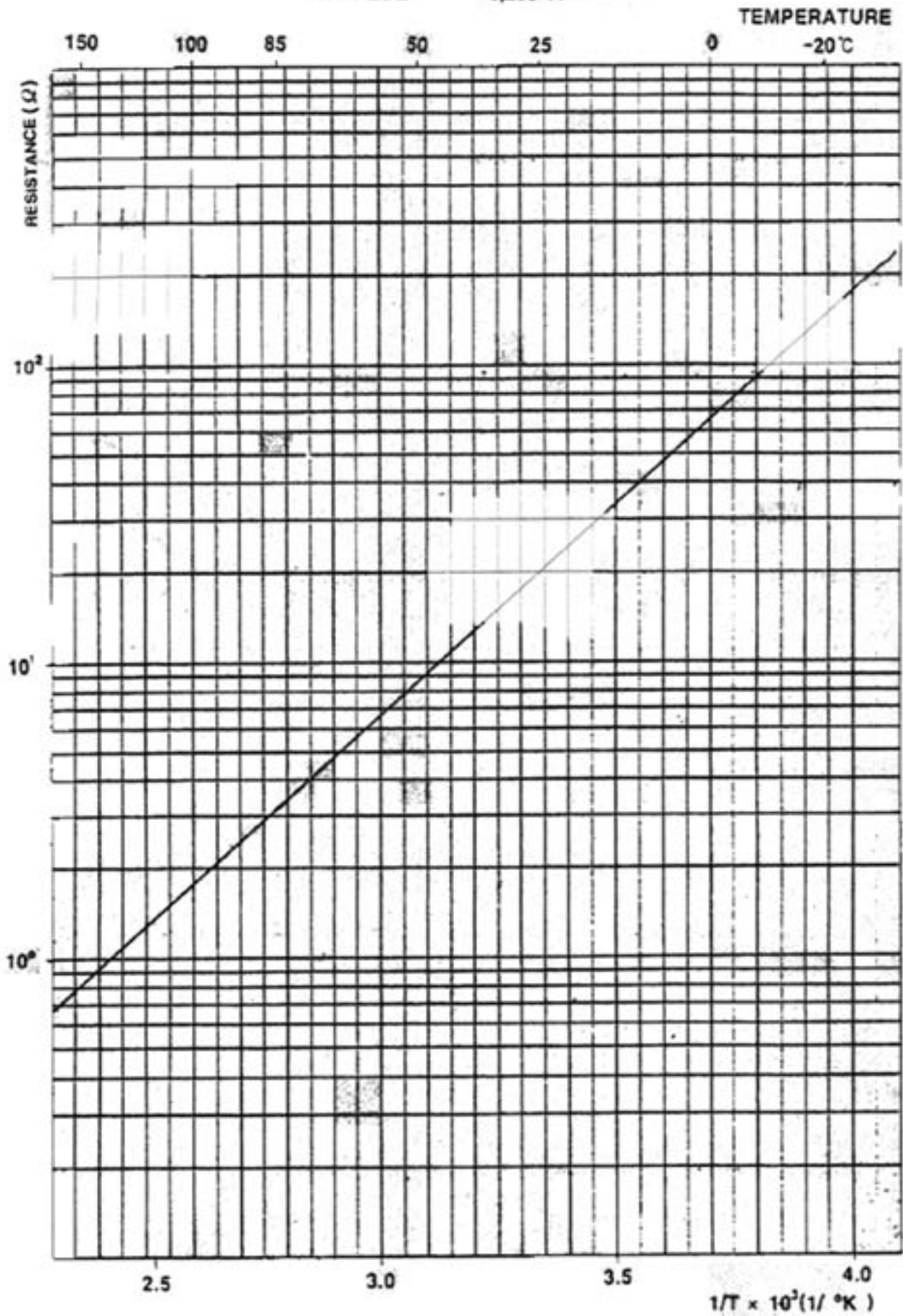

TYPICAL V-I CURVE FOR DSC SERIES

MODEL NO. : DSC - 20D - 22

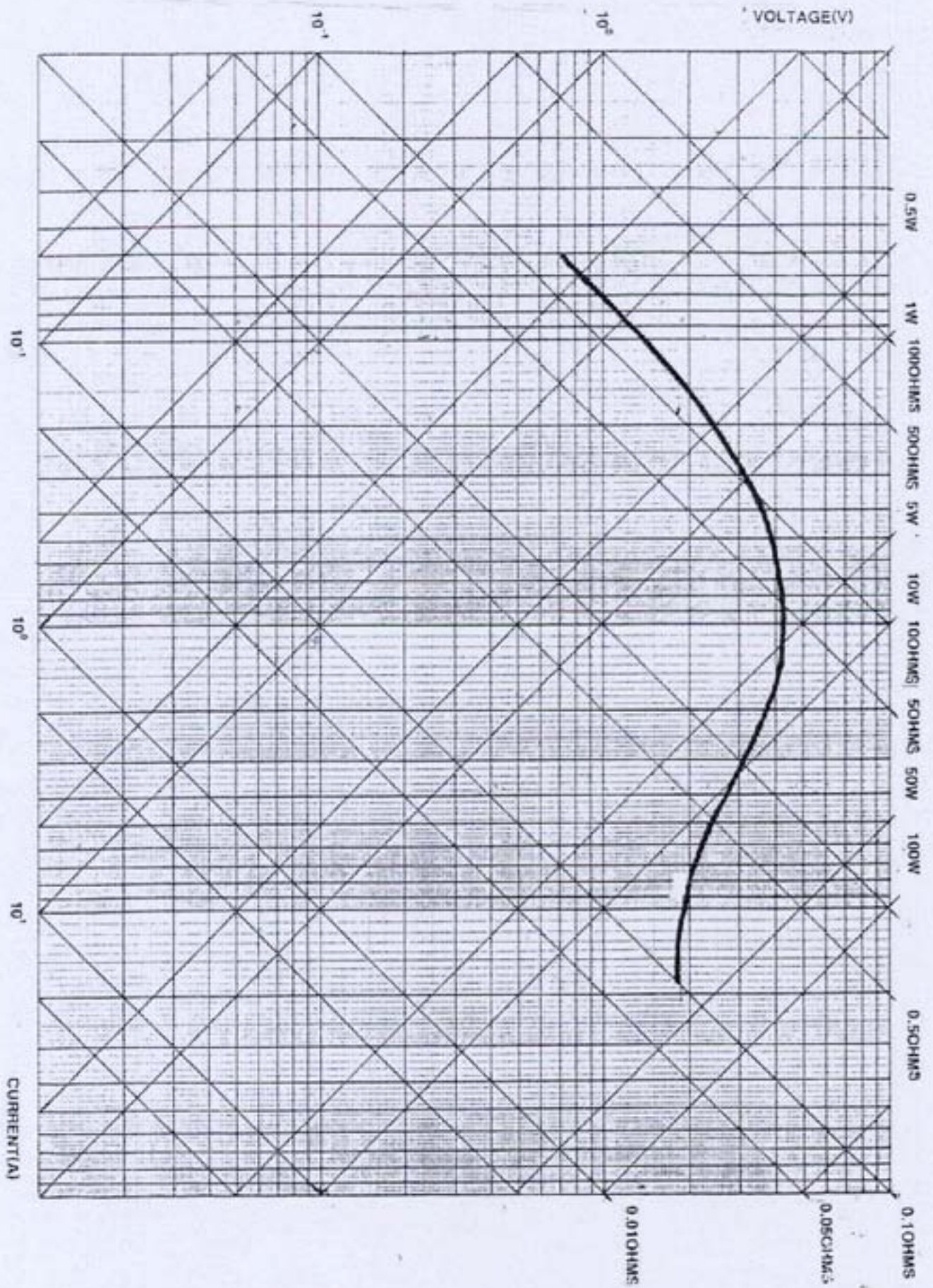

PACKING SHAPE

(Unit : mm)

1. INNER PACKING BOX

22/30 ϕ : 200pcs/vinyl pack \times 5pack = 1,000pcs/ inner box

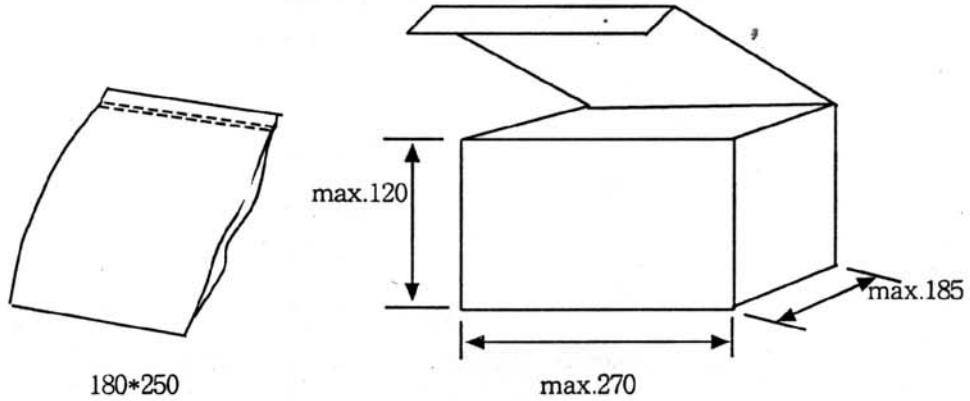

2. OUT PACKING BOX (INNER BOX 2 & 4EA)

* - 1,000pcs * 2ea = 2,000pcs

4ea = 4,000pcs

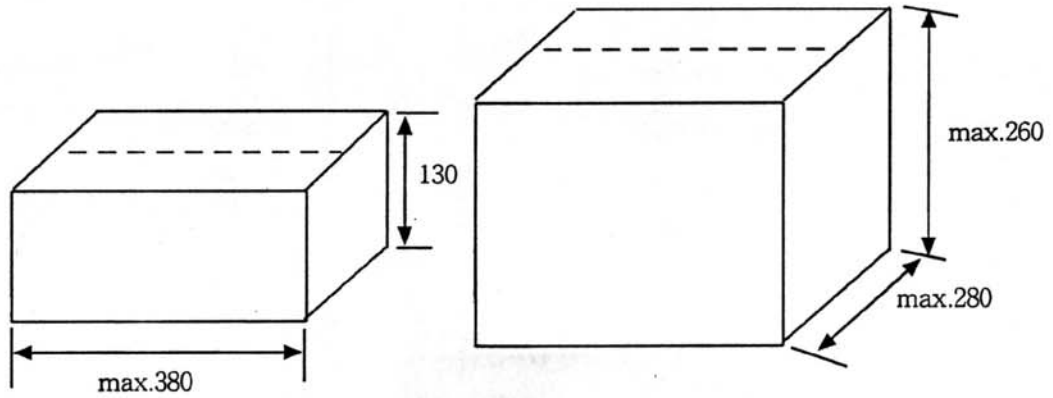

in case of 5,000/10,000pcs out box

in case of 10,000/20,000pcs out box