

**DSP201**  
**DSP202**

## DSP-Compatible Single/Dual DIGITAL-TO-ANALOG CONVERTERS

### FEATURES

- **ZERO-CHIP INTERFACE TO DSP ICs:**  
AD, AT&T, MOTOROLA, TI
- **SINGLE CHANNEL: DSP201**
- **DUAL CHANNEL: DSP202**  
Two Serial Inputs or Cascade from Single 32-Bit Word
- **UPDATE RATE TO 500kHz**
- **DYNAMIC SPECIFICATIONS:**  
Signal/(Noise + Distortion) = 90dB;  
THD = -92dB
- **USER SELECTABLE 16-BIT OR 18-BIT DATA WORDS**

### DESCRIPTION

The DSP201 and DSP202 are high performance digital-to-analog converters designed for simplicity of use with modern digital signal processing ICs. Both are complete with all interface logic for use directly with DSP ICs, and provide analog output voltages updated at up to 500kHz.

The DSP201 offers a single complete voltage output channel, accepting either 16 bits or 18 bits of input data, and can be driven by 16-bit, 24-bit, or 32-bit serial ports. The DSP202 offers two complete voltage output channels, with either two separate input ports, or a mode to drive both output channels from a single 32-bit word.

Both the DSP201 and DSP202 are packaged in standard, low-cost 28-pin plastic DIP packages. Each is offered in two performance grades to match application requirements.

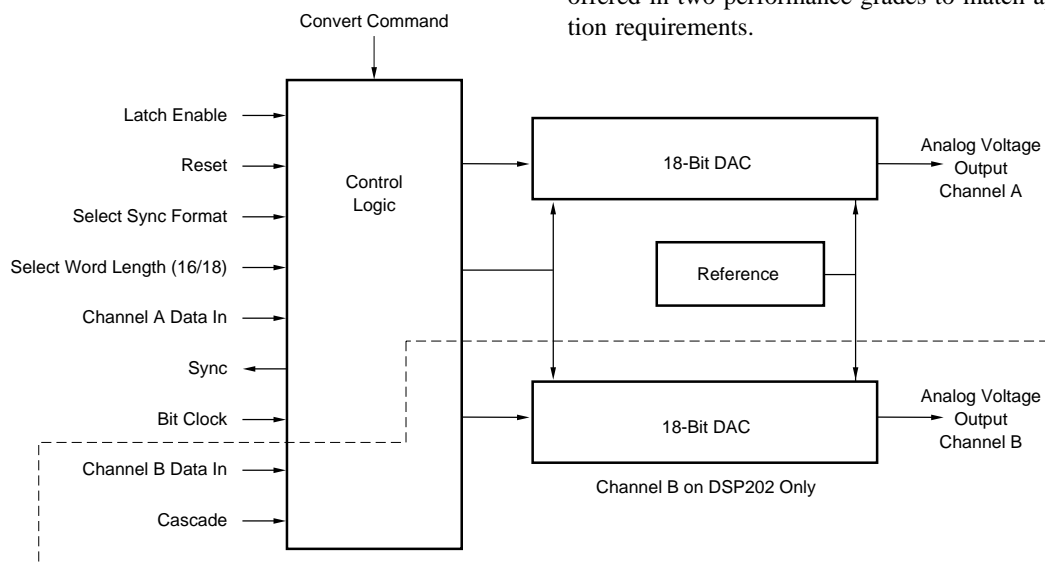

International Airport Industrial Park • Mailing Address: PO Box 11400 • Tucson, AZ 85734 • Street Address: 6730 S. Tucson Blvd. • Tucson, AZ 85706  
Tel: (520) 746-1111 • Twx: 910-952-1111 • Cable: BBRCORP • Telex: 066-6491 • FAX: (520) 889-1510 • Immediate Product Info: (800) 548-6132

# SPECIFICATIONS

## ELECTRICAL

T<sub>A</sub> = 0°C to 70°C, Output Update Frequency, f<sub>S</sub>, = 400kHz, V<sub>A+</sub> = V<sub>D+</sub> = +5V, V<sub>A-</sub> = V<sub>D-</sub> = -5V, unless otherwise specified.

PARAMETER	CONDITIONS	DSP201JP DSP202JP			DSP201KP DSP202KP			UNITS
		MIN	TYP	MAX	MIN	TYP	MAX	
<b>RESOLUTION</b>				18			*	Bits
<b>DYNAMIC RANGE</b>			108			*		dB
<b>ANALOG OUTPUT</b>								
Voltage Range	R <sub>L</sub> = 375Ω		±3		*			V
Impedance			0.1			*		Ω
Current	R <sub>L</sub> = 375Ω		±8			*		mA
Slew Rate	R <sub>L</sub> = 1.5kΩ, C <sub>L</sub> = 100pF		15			*		V/μs
Settling Time to 0.006% for Full-Scale Step	R <sub>L</sub> = 1.5kΩ, C <sub>L</sub> = 100pF		2.5			*		μs
<b>THROUGHPUT SPEED (1)</b>								
Update Rate	CASC = LOW on DSP202	500			*			kHz
DSP202 in Cascade Mode	CASC = HIGH	300						kHz
<b>AC ACCURACY (2, 3)</b>								
Signal to (Noise + Distortion) Ratio	f <sub>OUT</sub> = 1kHz	82	86		88	90		dB(4)
	f <sub>OUT</sub> = 1kHz (-60dB)		30			32		dB
	f <sub>OUT</sub> = 10kHz	80	86		86	90		dB
Total Harmonic Distortion	f <sub>OUT</sub> = 1kHz		-90	-85		-92		dB
Channel Separation on DSP202	f <sub>OUT</sub> = 1kHz to 100kHz		105			*		dB
<b>DC ACCURACY</b>								
Integral Nonlinearity Error			±0.006			±0.004		%
Differential Nonlinearity Error			±0.006			±0.004		%
Bipolar Zero Error (5)			±10			*		mV
Bipolar Zero Error Drift			20			*		ppm FSR/°C
Bipolar Zero Mismatch (5)	DSP202 Channels		5			*		mV
Gain Error			1	3		*	*	%
Gain Error Drift			100			*		ppm/°C
Gain Error Mismatch	DSP202 Channels		1	3		*	*	%
Digital Feedthrough	ENABLE = HIGH		-105			*		dB
Power Supply Sensitivity	-5.1 < V <sub>A-</sub> , V <sub>D-</sub> < -4.9 +4.9 < V <sub>A+</sub> , V <sub>D+</sub> < +5.1		-60			*		dB
			-60			*		dB
<b>DIGITAL INPUTS</b>								
Format					Serial; MSB first; 16/18-bit and Cascaded			
Coding					Binary Twos Complement			
Logic Levels								
V <sub>IL</sub>	I <sub>IL</sub> = ±10μA	0		+0.8	*		*	V
V <sub>IH</sub>	I <sub>IH</sub> = ±10μA	+2.4		+5	*		*	V
Data Transfer Clock								
Frequency				12	*		*	MHz
Duty Cycle		40	50	60	*	*	*	%
<b>DIGITAL OUTPUTS</b>								
V <sub>OL</sub>	I <sub>OL</sub> = 4mA	0		+0.4	*		*	V
V <sub>OH</sub>	I <sub>OH</sub> = 4mA	+2.4		+5	*		*	V
<b>POWER SUPPLIES</b>								
Rated Voltage								
V <sub>A+</sub>		+4.75	+5	+5.25	*	*	*	V
V <sub>A-</sub>		-5.25	-5	-4.75	*	*	*	V
V <sub>D+</sub>		+4.75	+5	+5.25	*	*	*	V
V <sub>D-</sub>		-5.25	-5	-4.75	*	*	*	V
Current								
I <sub>A+</sub>			18			*		mA
I <sub>A-</sub>			17			*		mA
I <sub>D+</sub>			13			*		mA
I <sub>D-</sub>			25			*		mA
Power Consumption			365	450		*	*	mW
<b>TEMPERATURE RANGE</b>								
Specification		0		+70	*		*	°C
Storage		-40		+125	*		*	°C

NOTES: (1) The data transfer clock must be at least 24 times the update rate for the standard mode, and 40 times the update rate in the DSP202 Cascade Mode. (2) All dynamic specifications are based on 2048-point FFTs. (3) Data for the 1kHz test is bandlimited to 0 to 20kHz. Data for the 10kHz test is bandlimited to 0 to 40kHz. (4) All specifications in dB are referred to a full-scale output, ±3Vp-p. (5) Adjustable to zero with external potentiometer.

# TYPICAL PERFORMANCE CURVES

$T_A = +25^\circ\text{C}$ ; Update Frequency,  $f_S = 400\text{kHz}$ ;  $V_{A+} = V_{D+} = +5\text{V}$ ;  $V_{A-} = V_{D-} = 5\text{V}$ ; SWL = HIGH; CASC = LOW; Output Bandwidth Limited to 20kHz; unless otherwise noted.

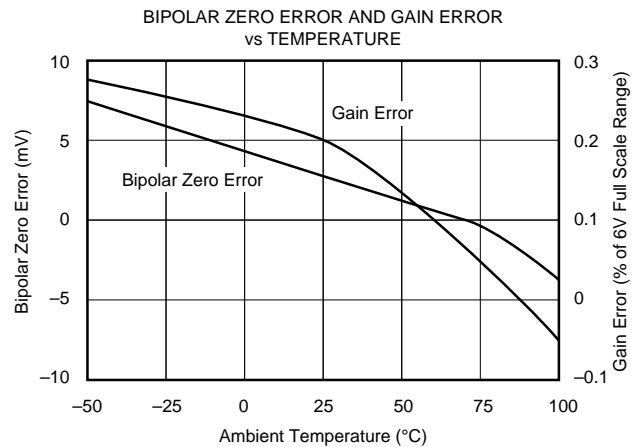
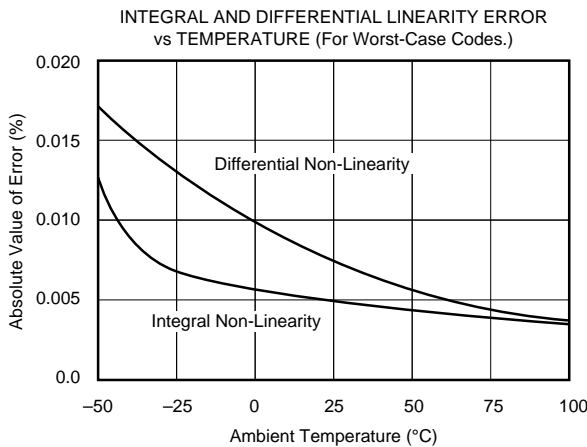
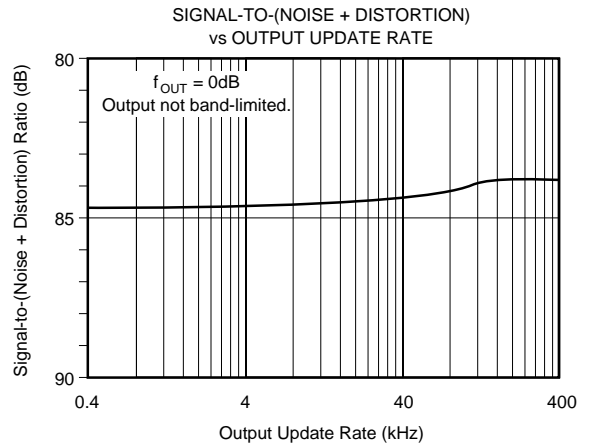
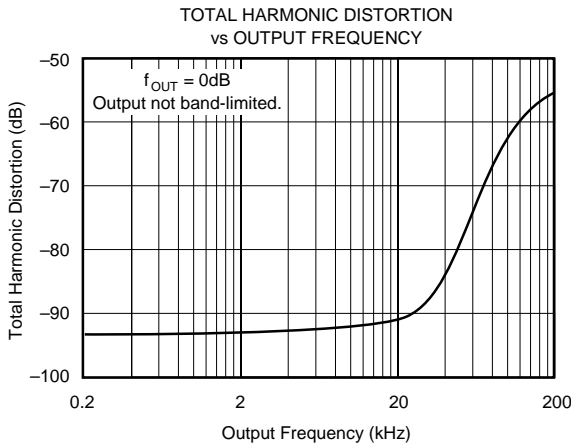
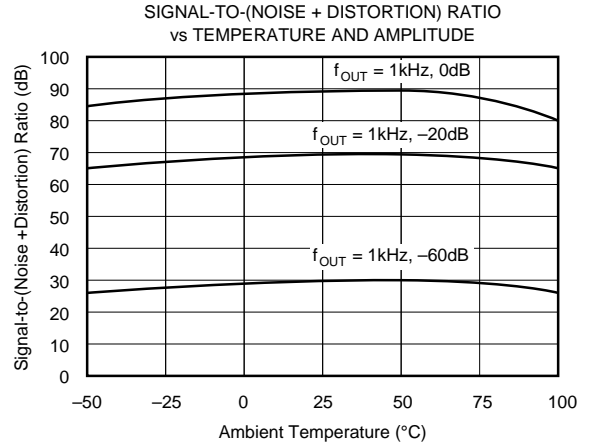
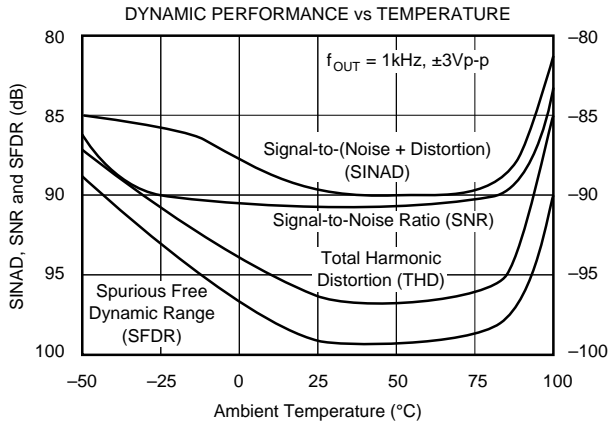

The information provided herein is believed to be reliable; however, BURR-BROWN assumes no responsibility for inaccuracies or omissions. BURR-BROWN assumes no responsibility for the use of this information, and all use of such information shall be entirely at the user's own risk. Prices and specifications are subject to change without notice. No patent rights or licenses to any of the circuits described herein are implied or granted to any third party. BURR-BROWN does not authorize or warrant any BURR-BROWN product for use in life support devices and/or systems.

# TYPICAL PERFORMANCE CURVES (CONT)

$T_A = +25^\circ\text{C}$ ; Update Frequency,  $f_s = 400\text{kHz}$ ;  $V_{A+} = V_{D+} = +5\text{V}$ ;  $V_{A-} = V_{D-} = 5\text{V}$ ; SWL = HIGH; CASC = LOW; Output Bandwidth Limited to 20kHz; unless otherwise noted.

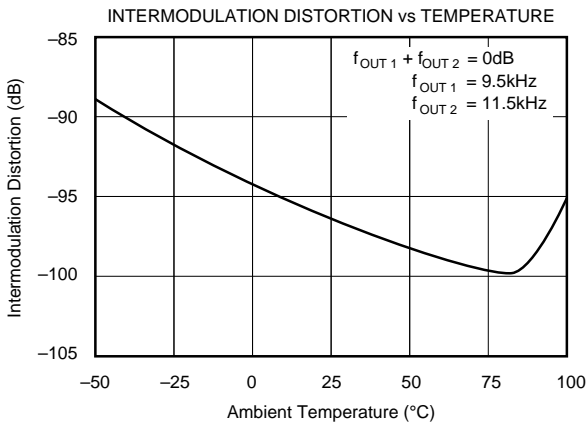
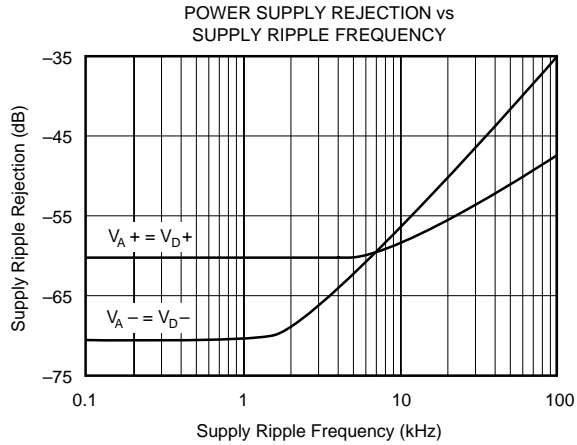
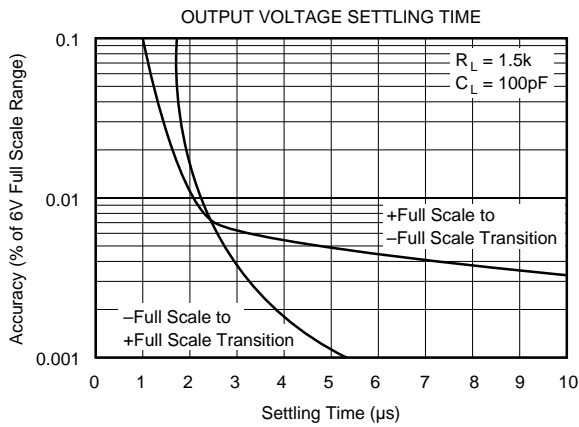

## ELECTROSTATIC DISCHARGE SENSITIVITY

The DSP201 and DSP202 are ESD (electrostatic discharge) sensitive devices, and normal standard precautions should be taken. Permanent damage may occur on unconnected devices subject to high energy electrostatic fields. When not in use, devices must be stored in conductive foam or shunts. The protective foam should be discharged to the destination socket before devices are removed.

### PACKAGE INFORMATION

MODEL	PACKAGE	PACKAGE DRAWING NUMBER <sup>(1)</sup>
DSP201JP	28-Pin Plastic DIP	215
DSP201KP	28-Pin Plastic DIP	215
DSP202JP	28-Pin Plastic DIP	215
DSP202KP	28-Pin Plastic DIP	215

NOTE: (1) For detailed drawing and dimension table, please see end of data sheet, or Appendix D of Burr-Brown IC Data Book.

### ABSOLUTE MAXIMUM RATINGS

$V_{A+}$ to Analog Common .....	+7V
$V_{A-}$ to Analog Common .....	-7V
$V_{D+}$ to Digital Common .....	+7V
$V_{D-}$ to Digital Common .....	-7V
Analog Common to Digital Common .....	$\pm 1\text{V}$
Control Inputs to Digital Common .....	-0.5 to $V_D + 0.5\text{V}$
Maximum Junction Temperature .....	150°C
Internal Power Dissipation .....	825mW
Lead Temperature (soldering, 10s) .....	+300°C
Thermal Resistance, $\theta_{JA}$ : Plastic DIP .....	50°C/W

### ORDERING INFORMATION

MODEL	NUMBER OF CHANNELS	SIGNAL-TO-(NOISE + DIST.) RATIO, dB min
DSP201JP	1	82
DSP201KP	1	88
DSP202JP	2	82
DSP202KP	2	88

## DSP201 PIN CONFIGURATION

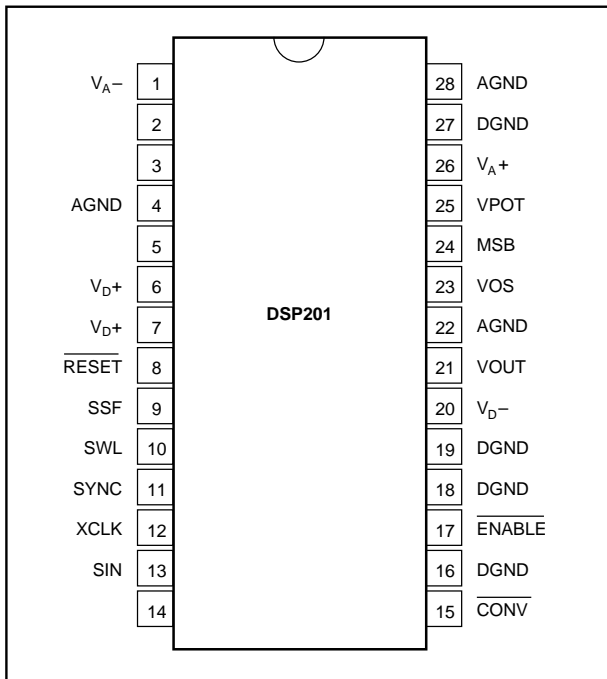

## DSP201 PIN ASSIGNMENTS

PIN #	NAME	DESCRIPTION
1	V <sub>A-</sub>	-5V Analog Power.
2		No Internal Connection.
3		No Internal Connection.
4	AGND	Analog Ground.
5		No Internal Connection.
6	V <sub>D+</sub>	+5V Digital Power.
7	V <sub>D+</sub>	+5V Digital Power.
8	RESET	Reset. If LOW, DAC output will be 0V after two convert commands, and will remain there as long as the Reset input is LOW. If HIGH, normal operation proceeds. Two convert commands are required after Reset goes from LOW to HIGH before the output will relate to the input word.
9	SSF	Select Sync Format In. Tie HIGH for use with Motorola and TI DSP ICs. Tie LOW for use with AT&T DSP ICs.
10	SWL	Select Word Length In. If HIGH, DSP201 accepts first 16 bits of data. If LOW, DSP201 accepts first 18 bits of data.
11	SYNC	Data Synchronization Output. Active HIGH when SSF is HIGH, active LOW when SSF is LOW.
12	XCLK	Data Transfer Clock Input.
13	SIN	Serial Data In. MSB first, Binary Two's Complement format.
14		No Internal Connection.
15	CONV	Convert Command In. DAC is updated on falling edge, and initiates clocking new data in.
16	DGND	Digital Ground.
17	ENABLE	Latch Enable In. If LOW, DAC output will be latched with new data word on falling edge of Convert Command. If HIGH, Convert Commands will be ignored.
18	DGND	Digital Ground.
19	DGND	Digital Ground.
20	V <sub>D-</sub>	-5V Digital Power.
21	VOUT	Voltage Out.
22	AGND	Analog Ground.
23	VOS	VOS Adjust In.
24	MSB	MSB Adjust In.
25	VPOT	Trim Reference Out for MSB adjustment.
26	V <sub>A+</sub>	+5V Analog Power.
27	DGND	Digital Ground.
28	AGND	Analog Ground.

## DSP202 PIN CONFIGURATION

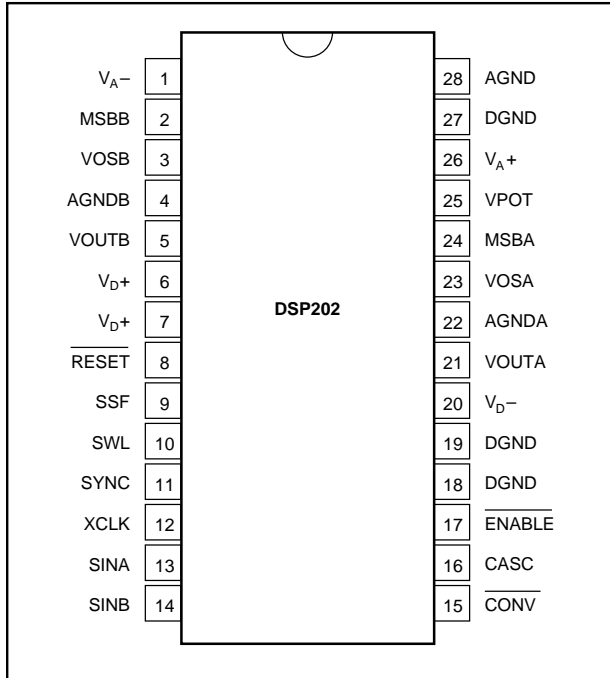

## DSP202 PIN ASSIGNMENTS

PIN #	NAME	DESCRIPTION
1	VA-	-5V Analog Power.
2	MSBB	Channel B MSB Adjust In.
3	VOSB	Channel B VOS Adjust In.
4	AGNDB	Channel B Analog Ground.
5	VOUTB	Channel B Voltage Out.
6	VD+	+5V Digital Power.
7	VD+	+5V Digital Power.
8	RESET	Reset. If LOW, DAC output will be 0V after two Convert Commands, and will remain there as long as the Reset input is LOW. If HIGH, normal operation proceeds. Two Convert Commands are required after Reset goes from LOW to HIGH before the output will relate to the input word.
9	SSF	Select Sync Format In. Tie HIGH for use with Motorola and TI DSP ICs. Tie LOW for use with AT&T DSP ICs.
10	SWL	Select Word Length In. If HIGH, DSP202 accepts first 16 bits of data. If LOW, DSP202 accepts first 18 bits of data. Must be HIGH if CASC is HIGH.
11	SYNC	Data Synchronization Output. Active HIGH when SSF is HIGH, active LOW when SSF is LOW.
12	XCLK	Data Transfer Clock Input.
13	SINA	Channel A Serial Data In. MSB first, Binary Two's Complement format. In Cascade Mode, connect to SINB and to DSP IC output.
14	SINB	Channel B Serial Data In. MSB first, Binary Two's Complement format. In Cascade Mode, connect to SINA and to DSP IC output.
15	CONV	Convert Command In. DAC is updated on falling edge, and initiates clocking new data in.
16	CASC	Select Cascade Mode In. If HIGH, DSP202 accepts a 32-bit word, and uses the first 16 bits to update channel A, and the second 16 bits to update channel B. In Cascade Mode, SINA and SINB are connected together. If CASC is LOW, data is strobed into both channels on each clock cycle.
17	ENABLE	Latch Enable In. If LOW, DAC output will be latched with new data word on falling edge of Convert Command. If HIGH, Convert Commands will be ignored.
18	DGND	Digital Ground.
19	DGND	Digital Ground.
20	VD-	-5V Digital Power.
21	VOUTA	Channel A Voltage Out.
22	AGNDA	Channel A Analog Ground.
23	VOSA	Channel A VOS Adjust In.
24	MSBA	Channel A MSB Adjust In.
25	VPOT	Trim Reference Out for MSB adjustments.
26	VA+	+5V Analog Power.
27	DGND	Digital Ground.
28	AGND	Analog Ground.

## THEORY OF OPERATION

The DSP201 and DSP202 are basic voltage output digital-to-analog converters with complete logic interface circuitry for ease of use with standard digital signal processing ICs. Data words are transmitted from the DSP IC on its serial port, leaving the DSP IC parallel ports free for digital communication.

The DSP201 and DSP202 are pipelined internally. When the user gives a convert command at time  $t$ , two actions are initiated. First, the data stored in the internal shift registers following the previous convert command (at  $t - 1$ ) is used to update the output D/A converters immediately. Second, the DSP201 or DSP202 transmits a synchronization pulse to the DSP IC and starts clocking new data into the shift register using the system Bit Clock. This data is then used to update the D/As when the  $t + 1$  convert command is received.

Both the DSP201 and DSP202 are 18-bit D/As internally. On-chip logic can be programmed to use 18-bits of data to update the D/A outputs, or can be programmed to update the D/A based on 16-bit data words. Additionally, the logic in the DSP202 can accept a 32-bit data word (the Cascade Mode), and update both D/A channels simultaneously with 16 bits each. All of these modes can be hard-wired or logic-controlled externally, so that no extra overhead on the part of the DSP IC is required.

In the 16-bit modes, the DSP201 and DSP202 will append zeros to the 16-bits transferred to each of the internal D/As, which are full 18-bit converters. The 18-bit word-length mode can be used with DSP ICs programmed for either 24-bit or 32-bit output words, in which case the DSP201 or DSP202 will clock in the first 18-bits of data after the synchronization pulse, and ignore additional information on the serial line. When programmed to accept 16-bit words, the DSP201 and DSP202 can be used with DSP ICs programmed to output 16-, 24-, or 32-bit words, and will ignore additional information after the first 16 bits on the serial line.

The DSP201 and DSP202 are complete voltage output D/A converters, with on-chip references and output amplifiers to drive  $\pm 3V$  into  $375\Omega$  loads. State-of-the-art bipolar technologies are used in the D/A section to maximize the output update rate, to maximize dynamic performance, and to eliminate glitch problems. Advanced plastic packaging methods makes this performance attainable economically.

## BASIC OPERATION

### DATA FORMAT AND OUTPUT LEVELS

The DSP201 and DSP202 accept serial data, MSB first, in standard Binary Two's Complement format. The length of the data words can be selected as shown below, and the D/A output level generated by a specific input code is shown in Table I.

As with all standard D/As, the output ranges from negative full scale ( $-3V$ ) to 1 LSB below positive full scale ( $+3V - 1\text{LSB}$ ). The bipolar output amplifiers are designed to drive  $375\Omega$  loads at full speed and accuracy.

### UPDATING THE OUTPUT

With  $\overline{\text{ENABLE}}$  (pin 17) LOW, the falling edge of a Convert Command arriving on CONV (pin 15) will immediately update the D/A outputs with the data stored in the internal shift registers following the previous Convert Command. The Convert Command can be asynchronous to any other signals or clocks without reducing accuracy, although system accuracy is often enhanced by synchronizing digital signals.

For a full-scale change in the input code, the output will typically settle to within  $\pm 0.006\%$  of its final level within  $2.5\mu\text{s}$ . The slew rate of the output amplifier is typically  $15V/\mu\text{s}$ , for a full power bandwidth close to  $800\text{kHz}$ . All of the specifications and typical performance curves are achieved with a full  $400\text{kHz}$  update rate, unless otherwise specified. The DSP201 and DSP202 are guaranteed operational to a full  $500\text{kHz}$  update rate, which exceeds the maximum Bit Clock rate for most standard DSP ICs.

### DATA TRANSFER

Data is transmitted serially to the DSP201 or DSP202, and is clocked into the internal shift registers on the rising edge of the external Data Transfer Clock or Bit Clock (XCLK input on pin 12.) This clock can be as fast as  $12\text{MHz}$ . The Data Transfer Clock can tolerate duty cycles from 40% to 60%.

As indicated in the timing diagrams in Figure 1, either 16- or 18-bits of data will be clocked into the DSP201 or DSP202, or 32-bits will be clocked into the DSP202 in the

INPUT CODE			OUTPUT VOLTAGE	
BINARY	16-BIT MODE AND DSP202 CASCADE MODE	HEX 18-BIT MODE	16-BIT MODE AND DSP202 CASCADE MODE	18-BIT MODE
0111...1111	7FFF	1FFFF	+2.999908V	2.999977V
0000...0000	0000	00000	0V	0V
1111...1111	FFFF	3FFFF	-92 $\mu\text{V}$	-23 $\mu\text{V}$
1000...0000	8000	20000	-3.000000V	-3.000000V
Theoretical LSB Size			91.6 $\mu\text{V}$	22.9 $\mu\text{V}$

TABLE I. Output Voltage vs Input Code.

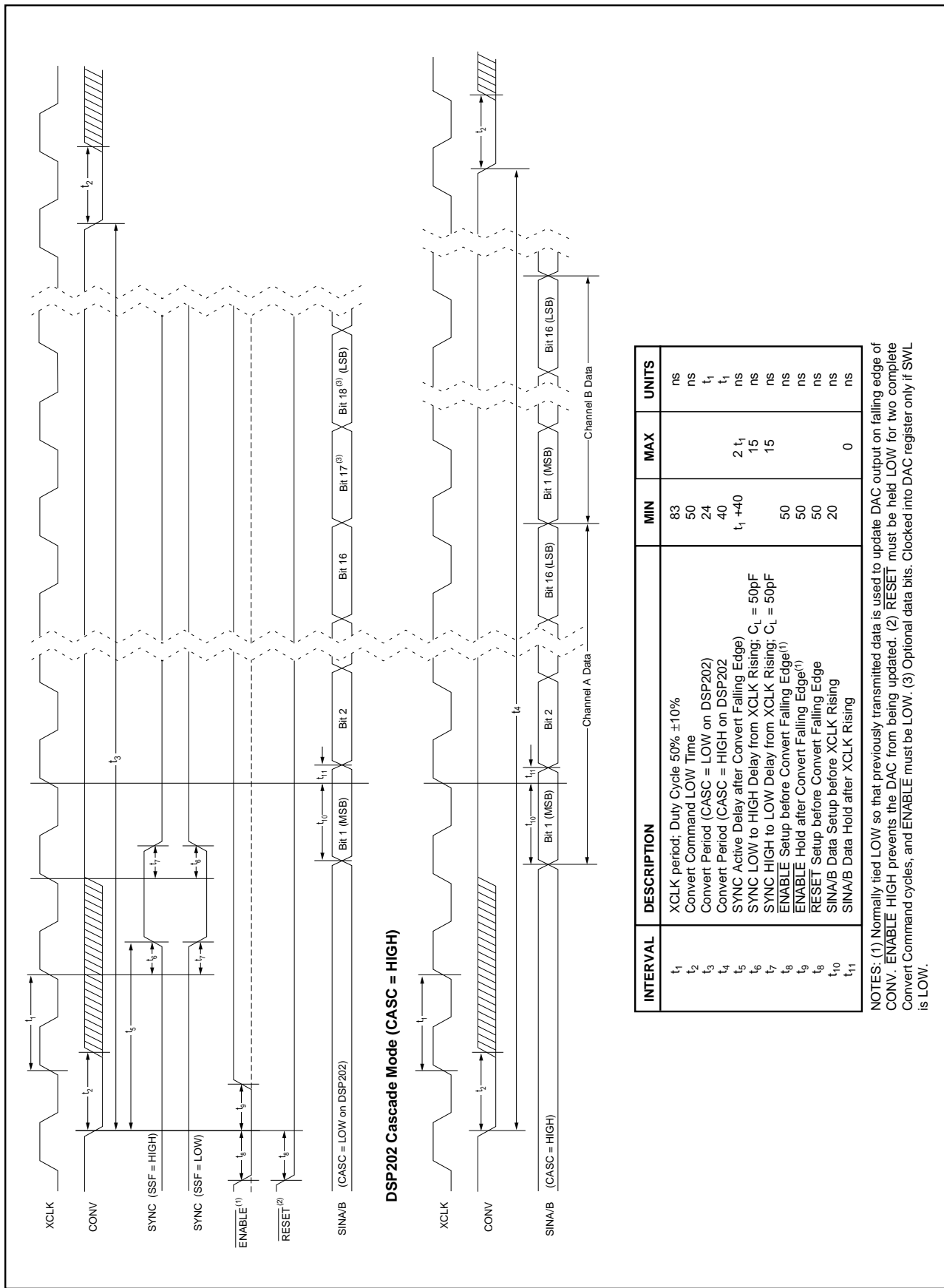

INTERVAL	DESCRIPTION	MIN	MAX	UNITS
$t_1$	XCLK period; Duty Cycle 50% $\pm 10\%$	83		ns
$t_2$	Convert Command LOW Time	50		ns
$t_3$	Convert Period (CASC = LOW on DSP202)	24		$t_1$
$t_4$	Convert Period (CASC = HIGH on DSP202)	40		$t_1$
$t_5$	SYNC Active Delay after Convert Falling Edge	$t_1 + 40$	$2 t_1$	ns
$t_6$	SYNC LOW to HIGH Delay from XCLK Rising; $C_1 = 50\text{pF}$		15	ns
$t_7$	SYNC HIGH to LOW Delay from XCLK Rising; $C_1 = 50\text{pF}$		15	ns
$t_8$	ENABLE Setup before Convert Falling Edge <sup>(1)</sup>	50		ns
$t_9$	ENABLE Hold after Convert Falling Edge <sup>(1)</sup>	50		ns
$t_{10}$	RESET Setup before Convert Falling Edge	50		ns
$t_{11}$	SINAB Data Setup before XCLK Rising	20		ns
	SINAB Data Hold after XCLK Rising		0	ns

NOTES: (1) Normally tied LOW so that previously transmitted data is used to update DAC output on falling edge of CONV. ENABLE HIGH prevents the DAC from being updated. (2) RESET must be held LOW for two complete Convert Command cycles, and ENABLE must be LOW. (3) Optional data bits. Clocked into DAC register only if SWL is LOW.

FIGURE 1. DSP201 and DSP202 Timing.



Cascade Mode, but internal digital overhead requires additional Data Transfer Clock cycles before a new Convert Command can be sent. The minimum time between Convert Commands is 24 times the Data Transfer Clock period for either the DSP201 or the DSP202 in standard modes, and 40 times the Data Transfer clock period for the DSP202 in the Cascade Mode. There is no maximum time between Convert Commands.

These additional clock cycles are used to set up the internal shift registers and logic, and are included in the specifications for maximum update rate. This means a 12MHz Bit Clock can achieve the maximum specified update rate of 500kHz.

### DATA SYNCHRONIZATION

The DSP201 and DSP202 have internal logic to generate a synchronization pulse (SYNC on pin 11) to signal the host processor to transmit data. The synchronization pulse is sent when a Convert Command is received, and the SYNC output changes on the rising edge of XCLK. Timing is shown in Figure 1.

The synchronization pulse can be programmed to be either active High or active Low, depending on the logic level input on SSF (Select Sync Format on pin 9.) If SSF is LOW, SYNC will be normally HIGH, and will transmit a LOW pulse after a Convert Command is received. If SSF is HIGH, SYNC will be normally LOW, and will transmit a HIGH pulse after a Convert Command is received. The SYNC pulse will be as wide as one clock cycle on the Data Transfer Clock input on XCLK (pin 12.)

### SELECTING WORD LENGTH

If the Select Word Length input (SWL, pin 10) is HIGH, the DSP201 or DSP202 will accept 16 bits of data after a Convert Command, with the timing shown in Figure 1. After these 16 bits, additional data on SIN (DSP201 pin 13) or SINA and SINB (DSP202 pins 13 and 14) will be ignored. Transparent to the user, the internal shift register will append two zeroes to the 16-bit data words before updating the D/As on the next Convert Command.

If SWL is LOW, the DSP201 or DSP202 will clock 18 bits of data into the internal shift register after a Convert Command, with the timing shown in Figure 1. Subsequent data on SIN (DSP201 pin 13) or SINA and SINB (DSP202 pins 13 and 14) will be ignored.

In the 16-bit mode, an increment of 1 LSB will change the D/A output by approximately 91.6 $\mu$ V (the 6V full scale range divided by 2<sup>16</sup>), while an LSB in the 18-bit mode will change the output approximately 22.9 $\mu$ V (6V/2<sup>18</sup>).

The DSP201 and DSP202 analog performance is tested in production using the 16-bit mode (with SWL HIGH), and the typical performance curves were generated using the 16-bit mode. Verification is made during final test that the 18-bit mode functions, but the extra resolution of these last two bits is not used when testing the analog performance.

### DSP202 CASCADE MODE

If CASC on the DSP202 (pin 16) is HIGH, the Cascade Mode is implemented. In this mode, SINA (pin 13) and SINB (pin 14) are strapped together and connected to the serial output port of an appropriate DSP IC or other data word source. A Convert Command initiates the transfer of a 32-bit word to the DSP202.

In the Cascade Mode, care must be taken to make sure SWL (pin 10) is HIGH.

### LATCH ENABLE

If  $\overline{\text{ENABLE}}$  (pin 17) is LOW, the D/A outputs will be latched with new data on the falling edge of the Convert Command. Taking  $\overline{\text{ENABLE}}$  HIGH causes the DSP201 or DSP202 to ignore Convert Commands. With  $\overline{\text{ENABLE}}$  HIGH when a Convert Command arrives at time t, data latched in the internal shift register after the Convert Command at t - 1 is not latched to the D/As, but a new synchronization pulse is still generated and the data in the shift register is overwritten. This feature allows multiple DSP201s or DSP202s to share a single DSP IC and still be independently updated.

### RESET

Taking  $\overline{\text{RESET}}$  (pin 8) LOW will cause the D/As to output 0V after two Convert Commands are received. The two Convert Commands clear out the internal shift registers, and data input on the serial input lines will be ignored while  $\overline{\text{RESET}}$  is low. This facilitates designing an analog output system that goes into a known, benign state either at power-up, after fault conditions or during a calibration cycle.  $\overline{\text{ENABLE}}$  (pin 17) must be LOW when resetting the DSP201 or DSP202 outputs to 0V.

After  $\overline{\text{RESET}}$  is taken HIGH, two Convert Commands are required before the output will relate to the input data. Also,  $\overline{\text{ENABLE}}$  must be LOW for the data to be latched to the D/As. The first Convert Command again latches the outputs at 0V, and the second Convert Command drives the output to the level determined by the data clocked in after the first Convert Command.

A  $\overline{\text{RESET}}$  command after power up is not required for proper operation of the DSP201 or DSP202.

### LAYOUT CONSIDERATIONS

Because of the high resolution, linearity and speed of the DSP201 and DSP202, system design problems such as ground path resistance, contact resistance and power supply quality become very important.

### GROUNDING

To achieve the maximum performance from the DSP201 or DSP202, care should be taken to minimize the effect of current flows in the system grounds that may corrupt the output voltages generated by the D/As. Pin 22 on the DSP201 and pins 4 and 22 on the DSP202 are the most

critical internal grounds, and care should be taken especially at these points to make them as close as possible to the same potential as the system analog ground. The design of the DSP201 and DSP202 insures that these pins will have minimal current flowing through them.

Internally, power currents are directed to the digital grounds (pins 18, 19, and 27) for internal digital currents, which are primarily switching currents, and to the analog grounds (pin 28, plus pin 4 on the DSP201) for analog currents, which are primarily from the internal current switches and the output amplifier. Pin 16 on the DSP201 is used internally as a logic level, and injects essentially no current into the ground.

Wherever possible, it is strongly recommended that separate analog and digital ground planes be used. With an LSB level of 92 $\mu$ V in 16-bit modes, and one quarter of that in 18-bit modes, the currents switched in a typical DSP system (processor, memory, etc.) can easily corrupt the output accuracy of the D/A's unless great care is taken to analyze and design for current flows.

## POWER SUPPLY DECOUPLING

All of the supplies should be decoupled to the appropriate grounds using tantalum capacitors in parallel with ceramic capacitors, as shown in Figures 2 and 3. For optimum performance of any high resolution D/A, all of the supplies need to be as clean as possible. If separate digital and analog supplies are available in a system, care should be taken to insure that the difference between the analog and the digital supplies is not more than 0.5V for more than a few hundred milliseconds, as may occur at power-on.

Separate -5V analog and digital supplies are not needed. These pins are kept separate internally to minimize coupling. Drive pin 20 from the -5V analog supply, and make sure that the decoupling shown in Figure 2 or 3 are placed as close as possible to the D/As.

## CALIBRATION AND ADJUSTMENT OPTIONAL EXTERNAL OFFSET AND MSB TRIMS

All of the specifications for the DSP201 and DSP202, plus the typical performance curves, are based on the performance of these D/As without external trims. In most applications, external trims are not required.

If external trims are not used, pins 23, 24, and 25 on the DSP201 should be left open, as should pins 2, 3, 23, 24 and 25 on the DSP202. These pins should not be decoupled with capacitors or tied to any specific potential, or the noise on the D/A outputs may increase.

## ADJUSTING OFFSET

Where required by specific applications, offsets can be trimmed using the circuits in Figure 2 (DSP201) or Figure 3 (DSP202.) As with all standard D/As, offset on the DSP201 and DSP202 means the difference of the output from the ideal negative full scale value. The DSP201 and DSP202 use

a current switching D/A architecture, and the current from this is internally amplified to produce a  $\pm 3$ V output range. Negative full scale output thus results from having all of the internal current switches turned off. Offset on the DSP201 and DSP202 should not be confused with the delta from 0V with an input code of 0000...0000 (0000 hex for 16-bit Modes, 00000 hex for 18-bit Modes). This is often described as bipolar zero error, and includes the effects of both offset and gain error.

To trim the offsets, first latch the D/As with 1000...0000 (8000 hex or 20000 hex). Then adjust the offset adjustment pots to produce an output of -3.000000V.

## ADJUSTING THE MSB WEIGHT

The MSB adjustment circuitry shown in Figure 2 for the DSP201 and in Figure 4 for the DSP202 basically change the weight of the MSB by adding to or subtracting from the current controlled by the internal MSB switch.

Depending on the application, the MSB adjustments can be made in one of three different ways to optimize the system performance using the DSP201 or DSP202. For dynamic performance, the MSB can be adjusted to minimize distortion of either a full-scale or low level sine-wave output. For applications stressing differential linearity, the 0000...0000 (0000 hex or 00000 hex) to 1000...0000 (FFFF hex or 3FFFF hex) transition can be trimmed to change the output of the D/As precisely 1 LSB (92 $\mu$ V in the 16-bit Mode or 23 $\mu$ V in the 18-bit Mode.)

To adjust for minimum distortion of full-scale sinewaves, strobe the inputs to the DSP201 or DSP202 with codes representing ideal full scale sine waves, then trim the MSB adjustment circuit to minimize distortion, as measured by either a distortion analyzer or by digitizing the output with an appropriate A/D and running FFT analyses.

In many audio applications, it is more appropriate to adjust for minimum distortion with low level sinewave outputs. This minimizes zero-crossover error, which can be a concern in high-end audio systems. To do this, strobe the inputs to the DSP201 or DSP202 with codes representing ideal low-level sine waves (-60dB from full scale works well), and then trim the MSB adjustment circuit to minimize distortion, again using a distortion analyzer or FFT analyses to check the results of the trims.

The MSB adjustment circuits can also be used to trim the D/A outputs directly for the transition from 0000...0000 (0000 hex or 00000 hex) to 1111...1111 (FFFF hex or 3FFFF hex), eliminating differential linearity error at the major carry. Ideally, this transition of the digital input code should cause the D/A outputs to change 92 $\mu$ V in the 16-bit Mode or 23 $\mu$ V in the 18-bit Mode. A simple way to make this adjustment is to continually load alternately the codes 1111...1111 (FFFF hex or 3FFFF hex) and 0000...0000 (0000 hex or 00000 hex) into the DSP201 or DSP202. An amplifier with sufficient gain can then drive an oscilloscope input, and the transition output step can be adjusted.

An alternative for calibrating on a bench is to tie SIN (DSP201 pin 13) or SINA and SINB (DSP202 pins 13 and 14) HIGH, and provide a Bit Clock and periodic Convert Commands. This loads 1111...1111 (FFFF<sub>HEX</sub> or 3FFF<sub>HEX</sub>), driving the output to 1LSB below 0V. Then periodically bring RESET (pin 8) LOW for at least two Convert Commands, which is the equivalent of loading all 0s, so the output is 0V. Now the output can be adjusted for an ideal transition step.

### ADJUSTING BIPOLAR ZERO ERROR

If it is important in a specific application to adjust bipolar zero error, the user should first adjust the MSB trim circuits, and then use the offset adjust circuits to adjust the outputs to 0V with input codes of all 0s (0000...0000; 0000 hex or 00000 hex.) In this case, it is not possible to also trim offset at -Full Scale, as described above.

### GAIN ERROR

Gain error on the DSP201 or DSP202 cannot be directly adjusted. If required in a specific application, gain can be trimmed out at the system level by adjusting the gain used in an output amplifier stage, such as would be used in any active output filter. In this case, the bipolar zero error should be adjusted first as discussed above. Then, the gain on the output amplifier should be adjusted to minimize the deviation from ideal for -Full Scale (1000...000; 8000 hex or 20000 hex) and +Full Scale (0111...1111; 7FFF hex or 1FFFF hex.)

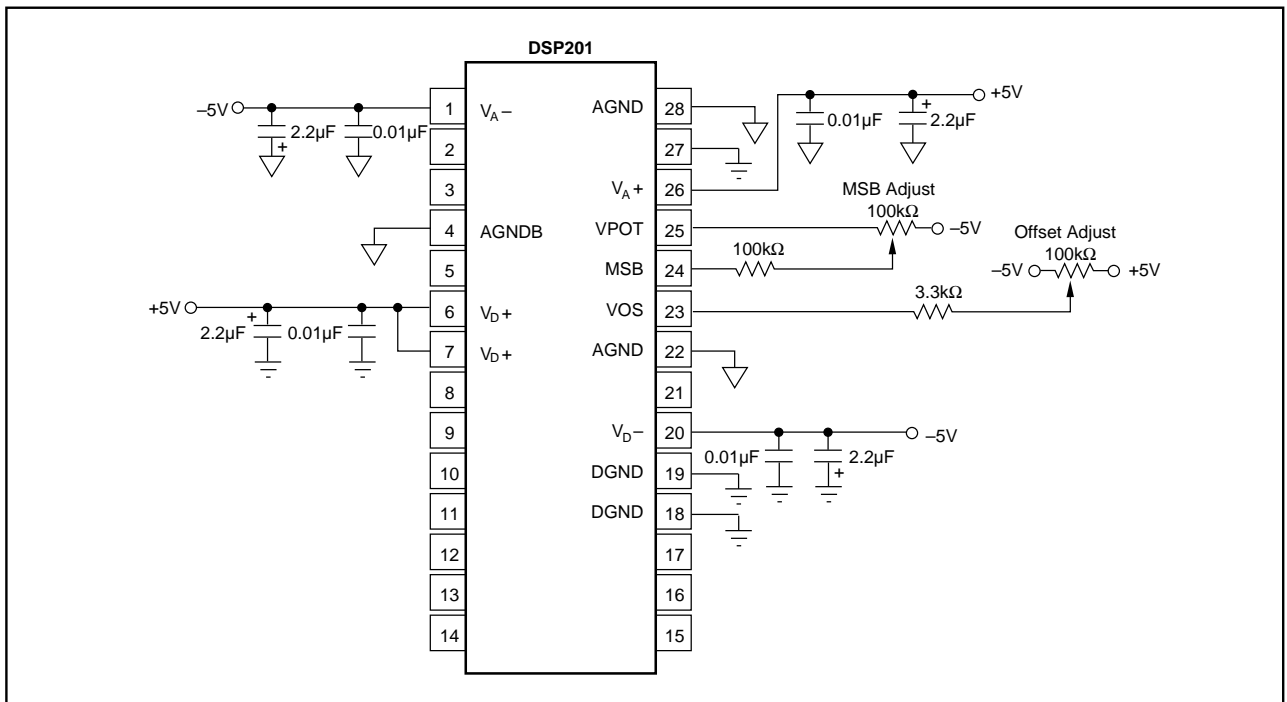

FIGURE 2. DSP201 Power Supply Connections and Optional Adjust Circuits.

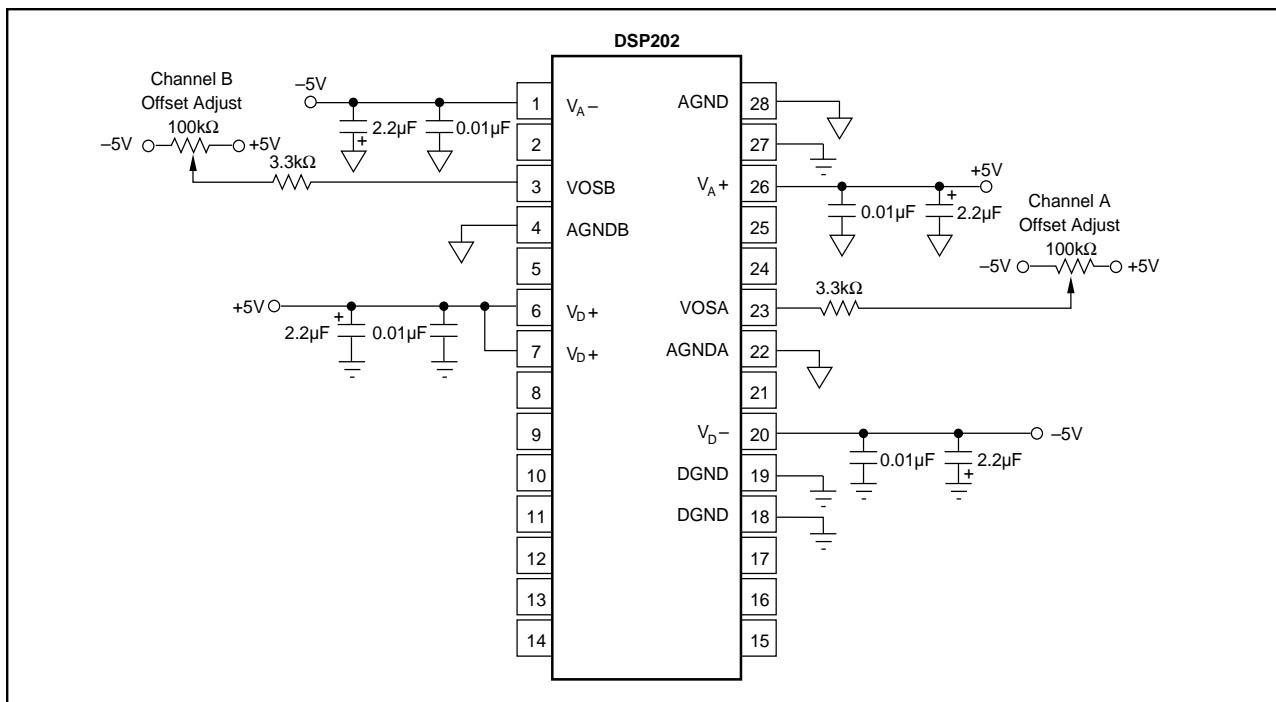

FIGURE 3. DSP202 Power Supply Connections and Optional Offset Voltage Adjustment.

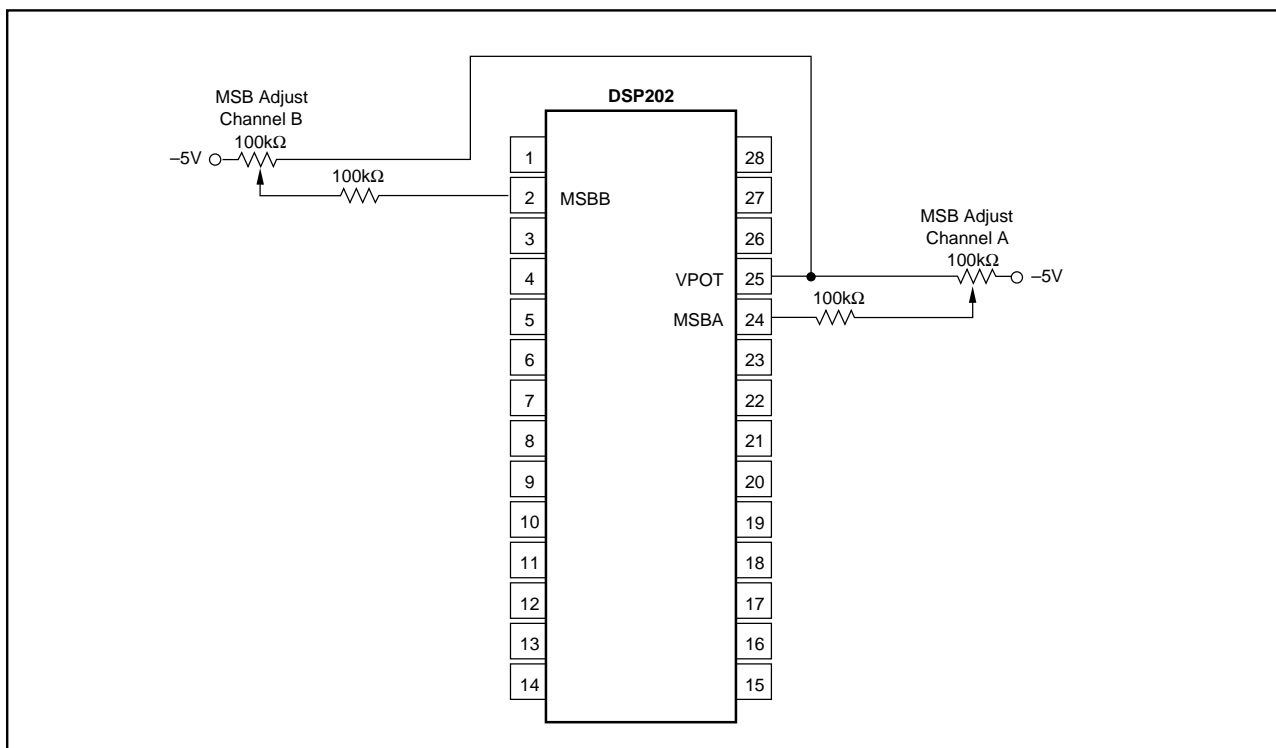

FIGURE 4. DSP202 Optional MSB Adjust Circuit.

# APPLICATIONS

## USING PARALLEL PORTS WITH THE DSP201 OR DSP202

Figure 5 shows a circuit for converting parallel outputs into the serial data stream required by the DSP201, and meets the requirements for timing signals. Doubling this circuit allows the DSP202 to be driven from a 32-bit parallel port. In most applications, this circuit can be easily incorporated into gate arrays or other programmed logic circuits already used in the system, since the extra gate count is not high.

## DEGLITCHING

Particularly in high resolution D/A converters, changing input codes may cause glitching on the output that excessively corrupts the dynamic purity of an output signal. The DSP201 and DSP202 are designed to minimize output glitching, and all of the performance specifications and typical performance curves are based on tests with no extra deglitching circuitry. In particular, the guaranteed Signal-to-(Noise + Distortion) performance would be impossible to attain with any significant glitching.

## COMPLETE ANALOG INPUT/OUTPUT SYSTEM

The DSP201 or DSP202 can be paired with the Burr-Brown DSP101 or DSP102 analog-to-digital converter to provide both analog input and analog output for a complete digital signal processing system. The DSP101 and DSP102 are respectively single and dual channel 200kHz sampling A/Ds with easy to use interfacing logic that complement the DSP201 and DSP202. Figure 6 shows a single channel analog input and output system based on a DSP201 and a DSP101, and the minimal connections required to interface to a DSP IC. A pair of channels can be implemented using a single DSP202 and a single DSP102, either with two separate DSP ICs, with a single DSP IC with dual serial input and output channels, or a single DSP IC capable of 32-bit words in the Cascade Mode.

For maximum flexibility in system design, the DSP201 or DSP202 D/As can be updated at a different rate than the conversion rate used on the DSP101 or DSP102 A/Ds, and either or both of these rates can be asynchronous to the clocks used with the DSP IC.

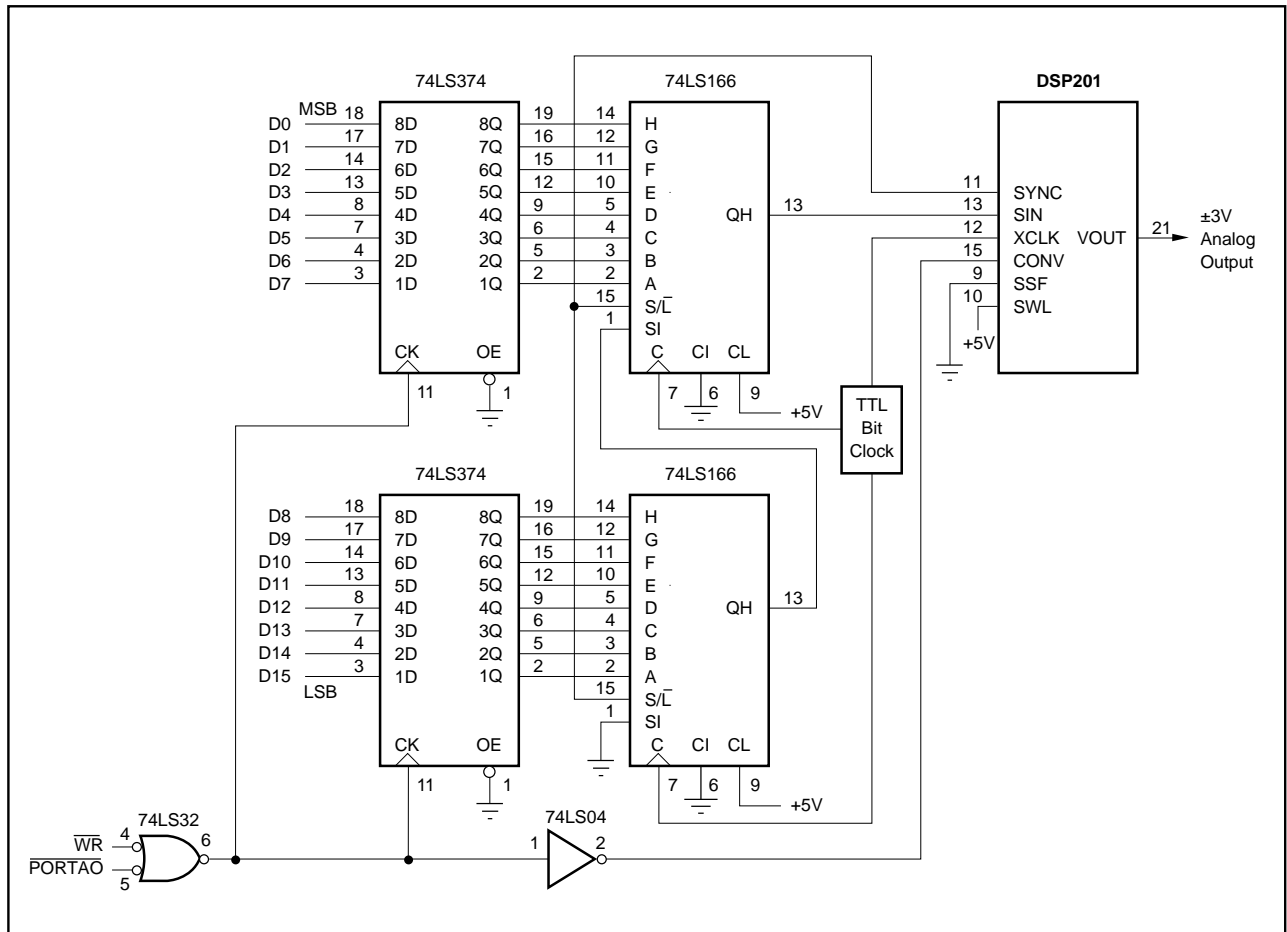

FIGURE 5. Driving the DSP201 from a 16-Bit Parallel Port.

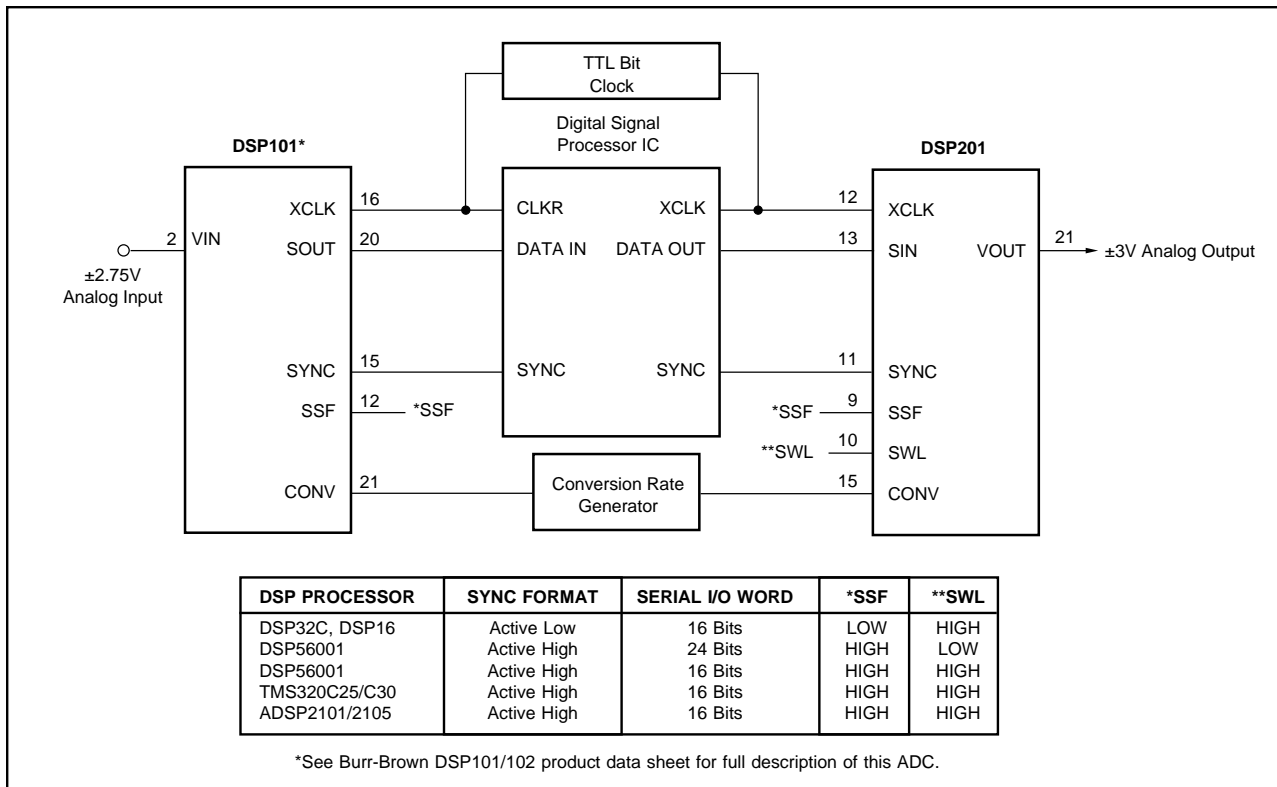

FIGURE 6. Analog Input and Analog Output System.

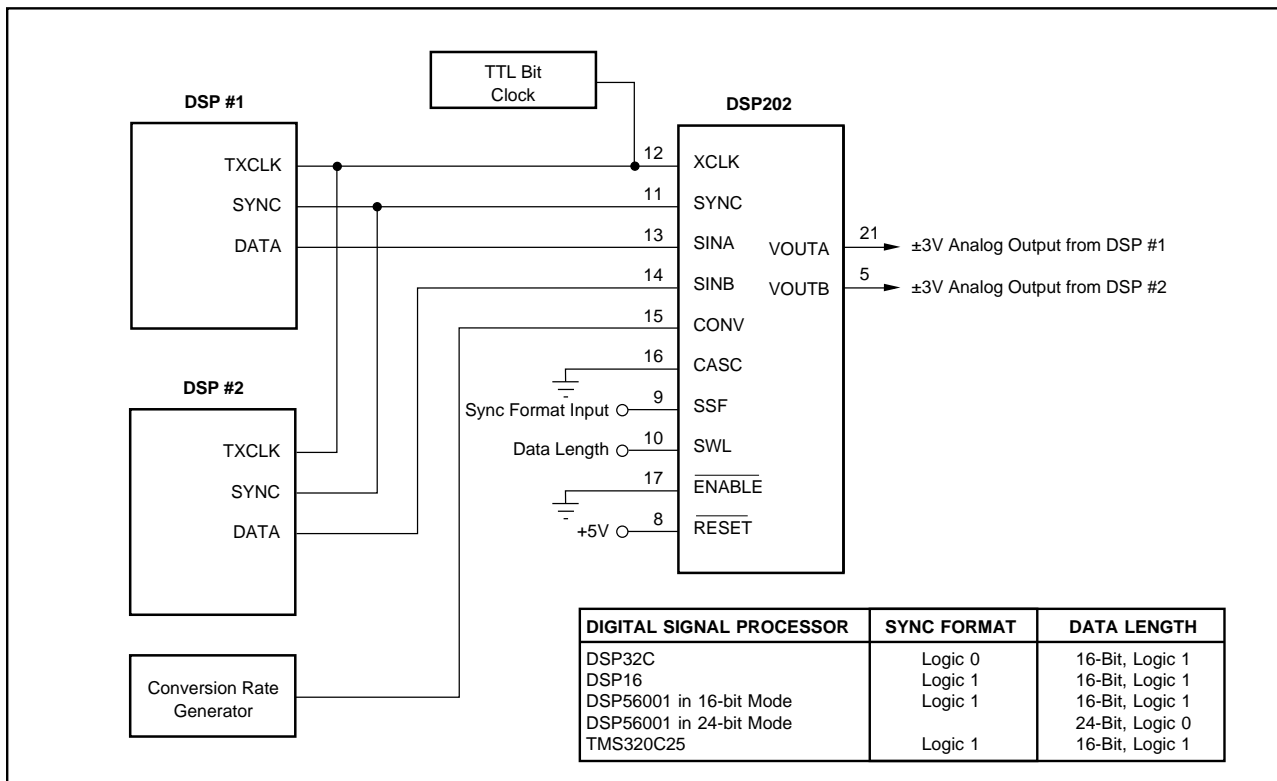

FIGURE 7. DSP202 with Dual DSP ICs.

## USING DSP201 AND DSP202 WITH TEXAS INSTRUMENTS DSP ICS

Figures 6 thru 12 show various ways to use the DSP201 and DSP202 with DSP ICs from the Texas Instruments TMS320Cxx series. For simplicity, all of these circuits are based on using the TMS320Cxx in the mode where SSF (Select Synch Format, pin 9) is tied HIGH, so that there is an active High synchronization pulse generated by the DSP201 or DSP202 after receiving a Convert Command. The synchronization pulse can be changed to active Low simply by making SSF LOW, where appropriate, without changing basic operation of the D/As. The timing for either synchronization mode is shown in Figure 1.

In all cases, the DSP201 and DSP202 expect to receive the data with the MSB first, and the TMS320Cxx needs to be programmed for this.

Figure 6 shows a circuit for using the TMS320C25 to generate a complete analog input and analog output system using the DSP201 plus the Burr-Brown DSP101 A/D.

Figure 7 shows how to use two TMS320C25 chips to drive the two channels of the DSP202.

The TMS320C30 has dual serial I/O ports, which can be used to drive the dual inputs on the DSP202, as shown in Figure 8. This circuit can maximize the update rate for the channels. Since the TMS320C30 can also output 32-bit words, both channels of the DSP202 can be updated from a single serial output port on the TMS320C30, using the cascade mode as shown in Figure 9.

Figures 10 and 11 show complete two-channel analog input and analog output systems consisting of three basic chips, the TMS320C30 plus a DSP202 dual D/A and a Burr-Brown DSP102 dual A/D. Figure 10 makes use of the dual serial I/O ports on the TMS320C30, and is shown with the DSP202 in the 16-bit Mode, which maximizes the possible

throughput rate on the system. Figure 11 makes use of the 32-bit word length mode in the TMS320C30 and the Cascade Mode on both the DSP202 and the DSP102 to provide two full analog I/O channels over a single serial I/O port on the TMS320C30. Thus, up to four complete, separate analog I/O channels could be operated using a single TMS320C30, by making use of the second serial port.

Figure 12 shows how to use a TMS320C25 to update the analog output of the DSP201.

## USING DSP201 AND DSP202 WITH MOTOROLA DSP ICS

Figure 13 shows how to use the DSP201 with a Motorola DSP56001. Using the DSP202 requires using two DSP56001s, as indicated in Figure 7.

The DSP56001 needs to be programmed for transmission of the MSB bit first with SYNC in the Bit Mode. If the DSP56001 is programmed for 16-bit data words, SWL (pin 10) on the DSP201 or DSP202 needs to be tied HIGH to select the 16-bit Mode. In the DSP56001 24-bit mode, the DSP201 or DSP202 can be programmed to accept data lengths of 16-bits (with SWL HIGH) or 18-bits (with SWL LOW), and will ignore the trailing bits on the serial line.

For use with the Motorola DSP56001, SSF (pin 9) on the DSP201 or DSP202 needs to be tied HIGH. This will cause the DSP201 or DSP202 to transmit an appropriate active High synchronization pulse on SYNC (pin 11) after a Convert Command is received by the DSP201 or DSP202. Timing is shown in Figure 1.

Even though the DSP201 or DSP202 require a minimum of 24 Bit Clock pulses between convert commands, the maximum update rate for the D/As using a 5MHz Bit Clock will still be over 200kHz ( $5\text{MHz} / 24 = 208.3\text{kHz}$ .)

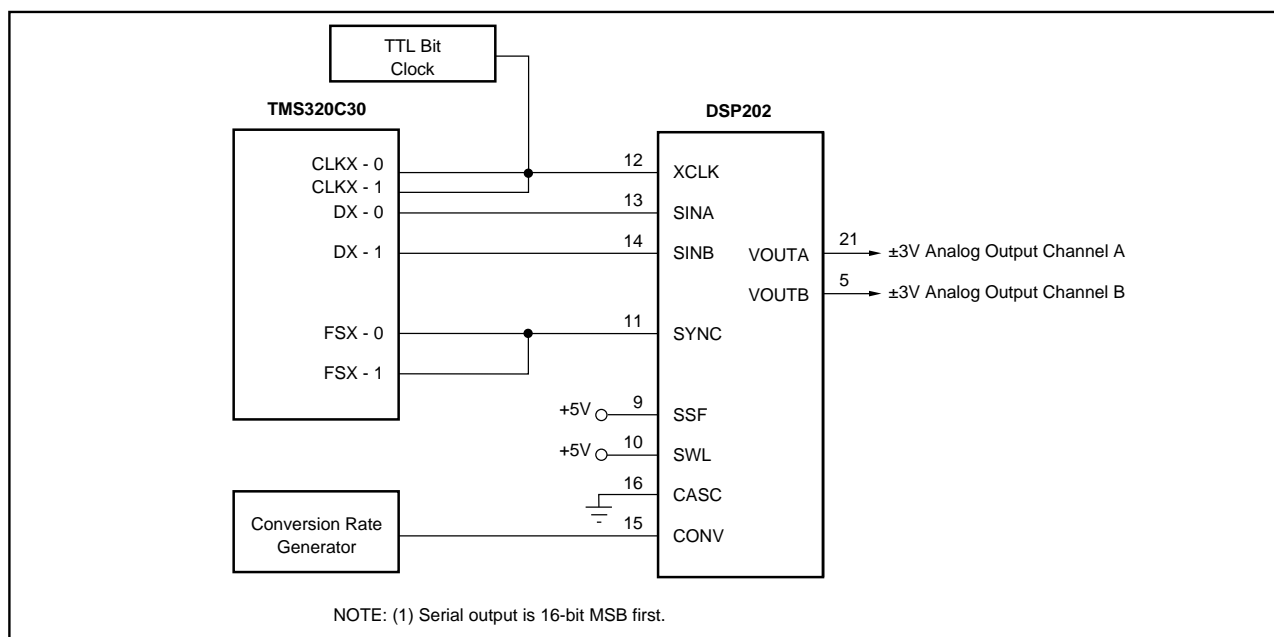

FIGURE 8. Using DSP202 with TMS320C30's Dual SIO.

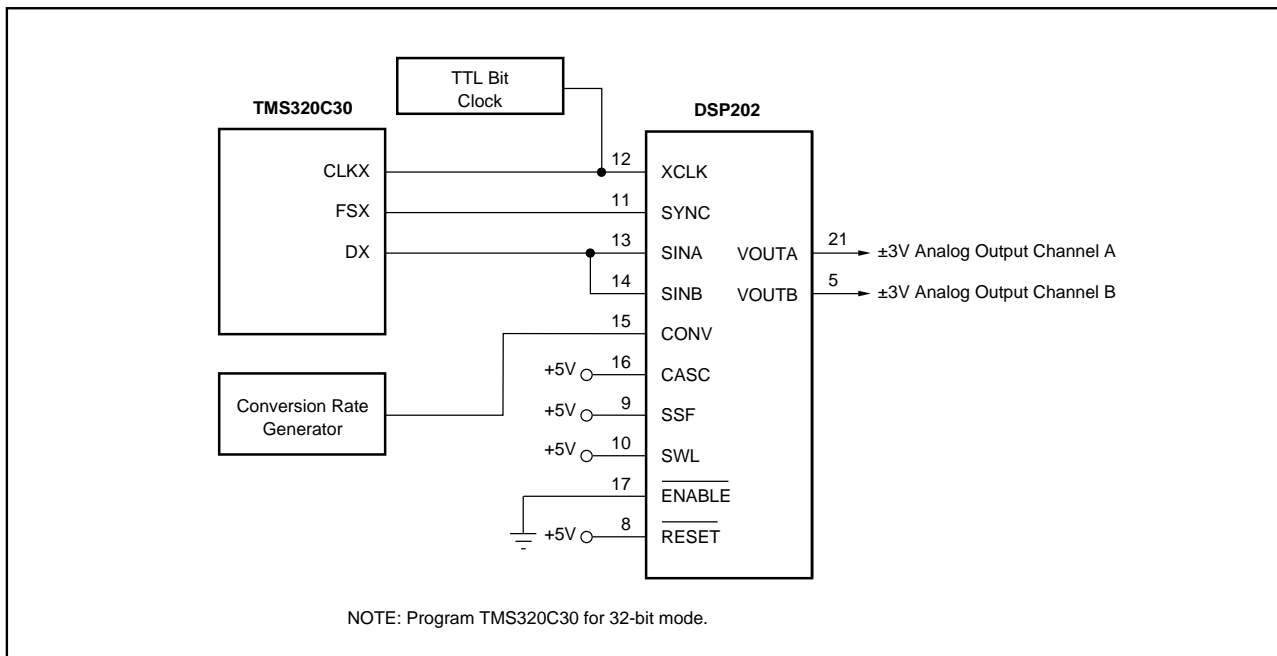

FIGURE 9. Using DSP202 with TMS320C30 in Cascade Mode.

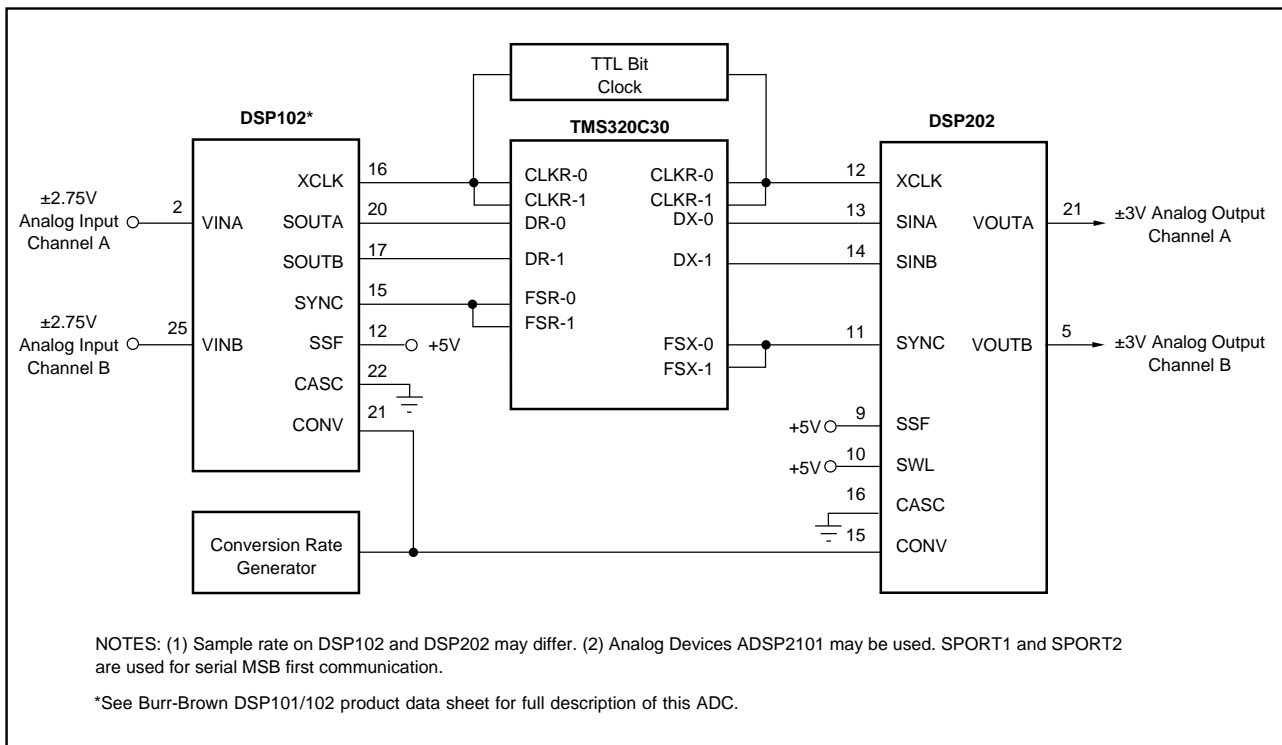

FIGURE 10. Two-Channel Analog Input and Output System with TMS320C30.



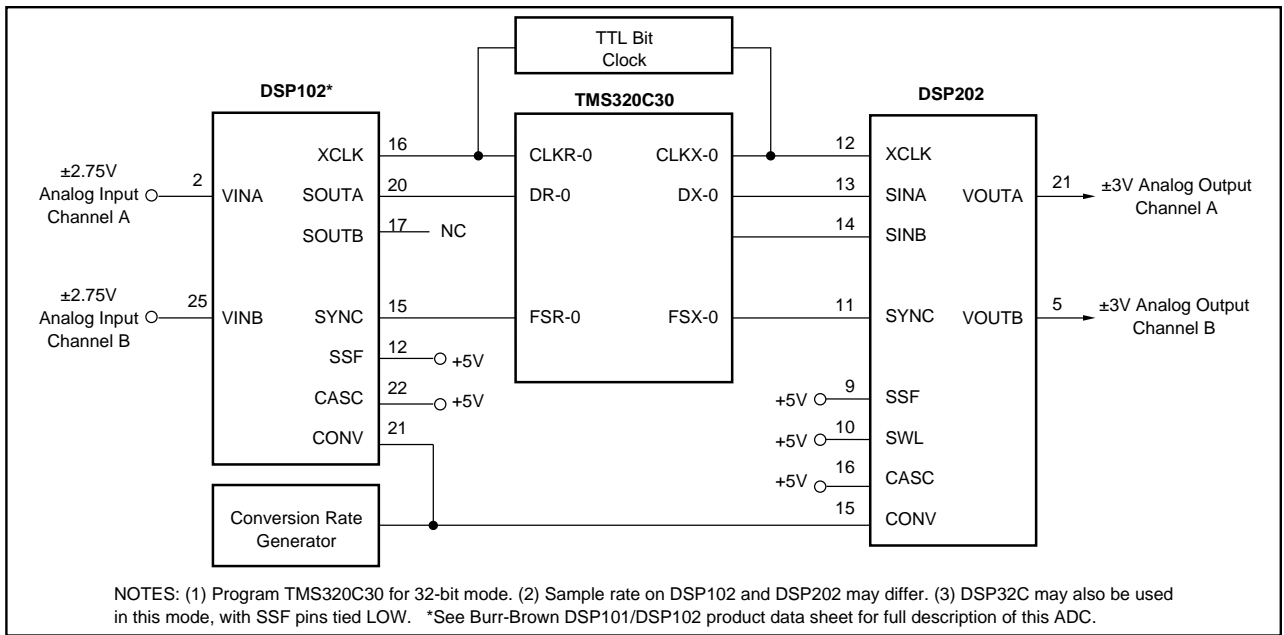

FIGURE 11. Two-Channel Analog Input and Output System with TMS320C30 in Cascade Mode.

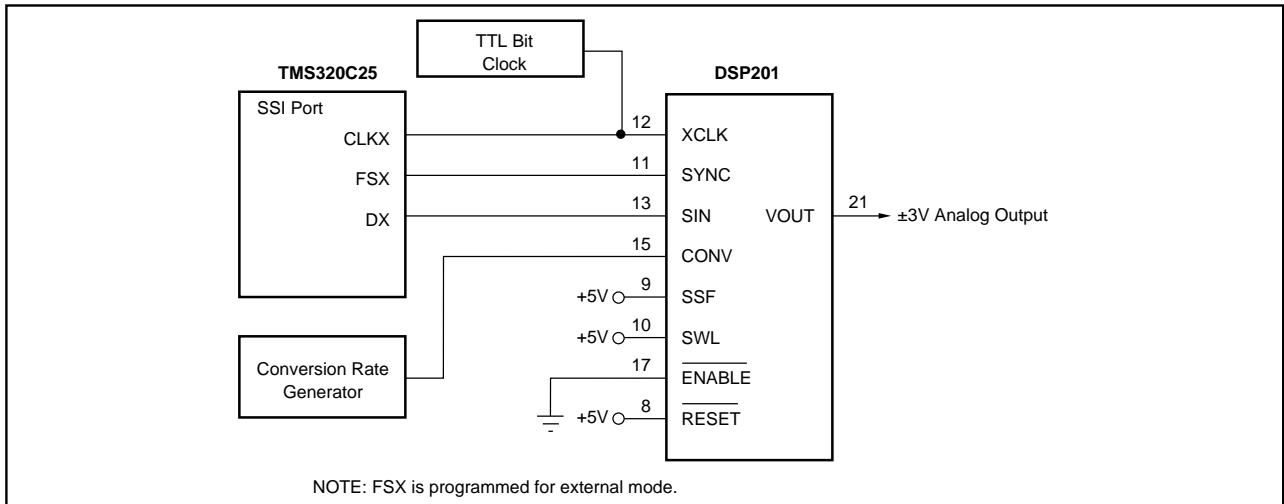

FIGURE 12. Using DSP201 with TMS320C25.

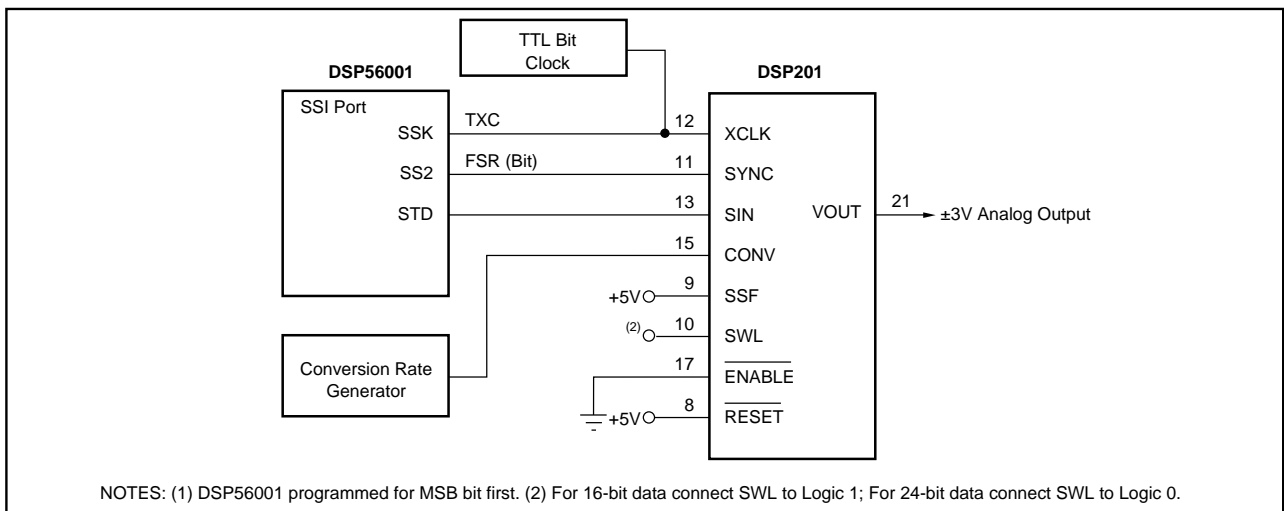

FIGURE 13. Using DSP201 with DSP56001.

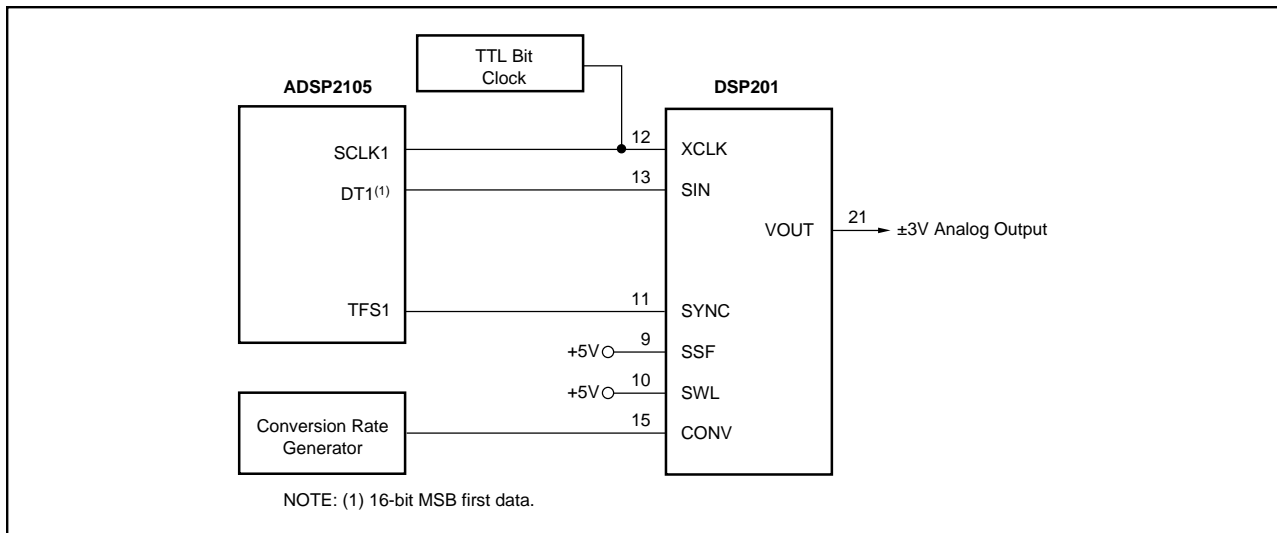

FIGURE 14. Using DSP201 with ADSP-2105.

### USING DSP201 AND DSP202 WITH ADI DSP ICS

When using the DSP201 or DSP202 with the ADSP2101 or ADSP2105, the processors need to be programmed to transmit the data with the MSB first.

Figure 14 shows the connections required to generate an analog output channel using an ADSP2105 with the DSP201. The same basic circuit can also be used to connect a DSP201 to the ADSP2101.

Figure 6 indicates how to build a complete analog input and analog output system using either the ADSP2101 or ADSP2105 with a DSP201 and a Burr-Brown DSP101 A/D.

The two serial ports on the ADSP2101 can also be used with the DSP202 to make two complete analog output channels as noted in footnote 2 of Figure 10.

### USING DSP201 AND DSP202 WITH AT&T DSP ICS

Figures 15, 16 and 17 show how to use the DSP201 and DSP202 with the DSP16 and DSP32C in different modes. The DSP IC needs to be programmed to transmit data with the MSB first, and the DSP201 or DSP202 needs to have SSF (Select Sync Format on pin 9) tied LOW so that the

D/As will output an appropriate active Low synchronization pulse after a Convert Command is received.

Figures 15 and 17 show the DSP32C and DSP16 respectively used with the DSP201 in the 16-bit Mode to generate a single analog output channel. With a 12MHz Bit Clock and the 24 Bit Clock cycles required by the DSP201 and DSP202 between Convert Commands, the output of Figure 15 can be updated at a full 500kHz (12MHz/24 = 500kHz.)

Figure 16 shows how to drive two analog output channels from a single 32-bit serial port on the DSP32C, using the Cascade Mode on the DSP202. With a 12MHz Bit Clock and the 40 Bit Clock cycles required between Convert Commands by the DSP for internal logic overhead, this circuit can update two separate analog outputs at 300kHz each from a single serial port (12MHz/40 = 300kHz.)

Figure 6 indicates how to build a complete analog input and analog output system using a DSP32C or DSP16 with a DSP201 and a Burr-Brown DSP101 A/D.

Figure 7 shows a two channel analog output system using a single DSP202 with two DSP32Cs or two DSP16s.

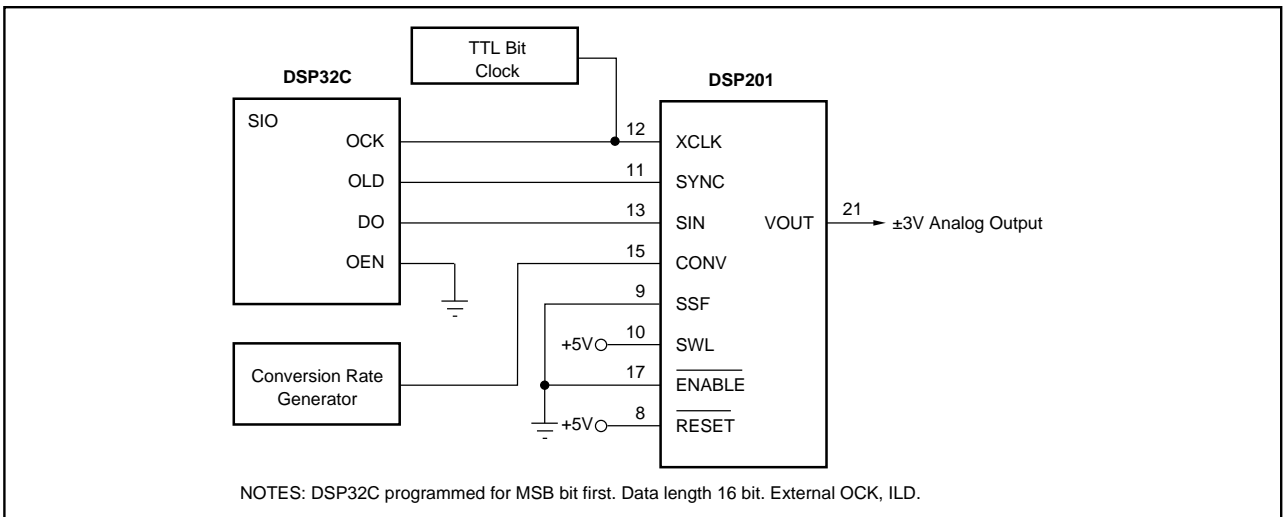

FIGURE 15. Using DSP201 with DSP32C with 16-Bit Data Words.

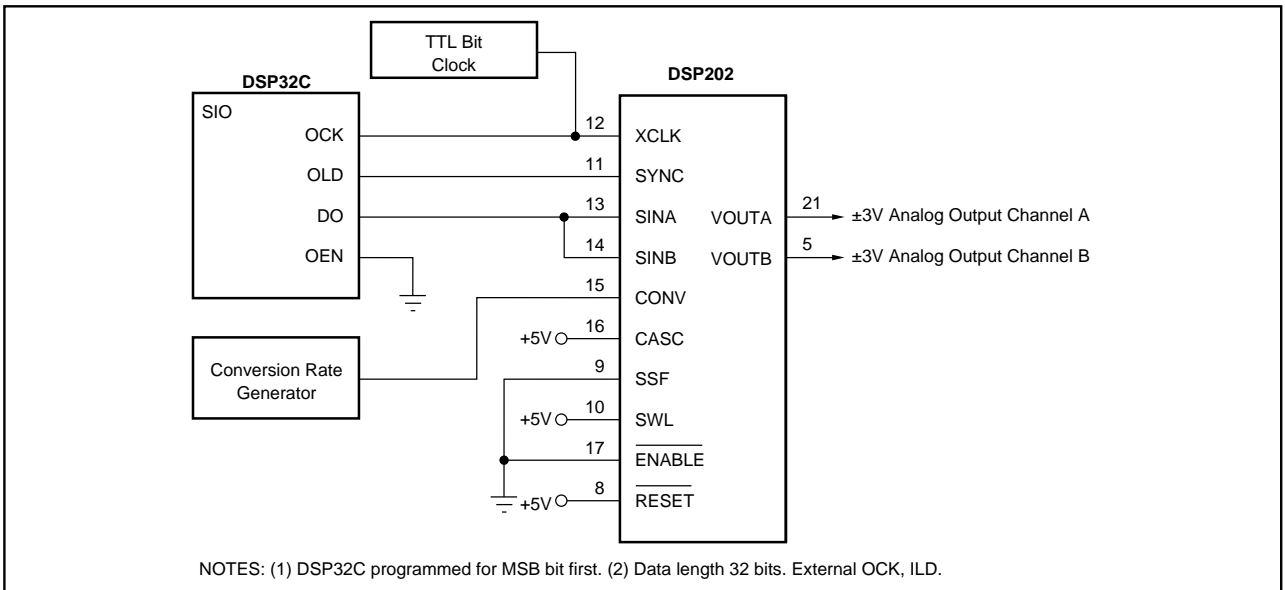

FIGURE 16. Using DSP202 with DSP32C in Cascade Mode.

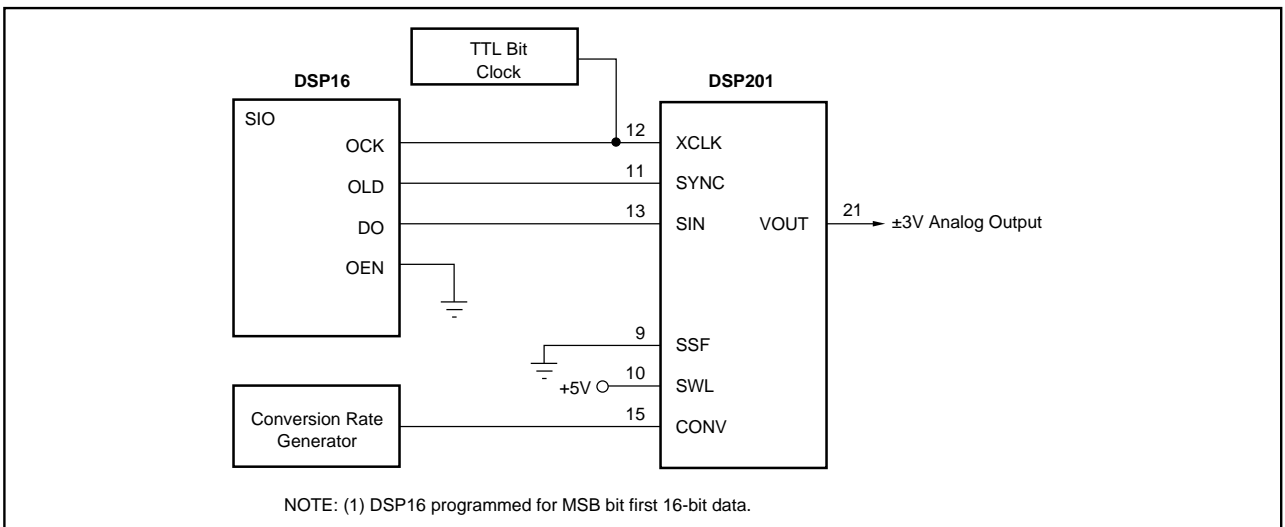

FIGURE 17. Using DSP201 with DSP16.