

**MODEL NUMBER
DSW21998**

GaAs SP2T

FEATURES

- 0.5 - 100 MHz
- High Intercept Points
- 0.6 dB Insertion Loss
- 5 mA, ±15 VDC
- Non Reflective
- TTL Control
- 14 Pin DIP

SP2T

www.DataSheet4U.com

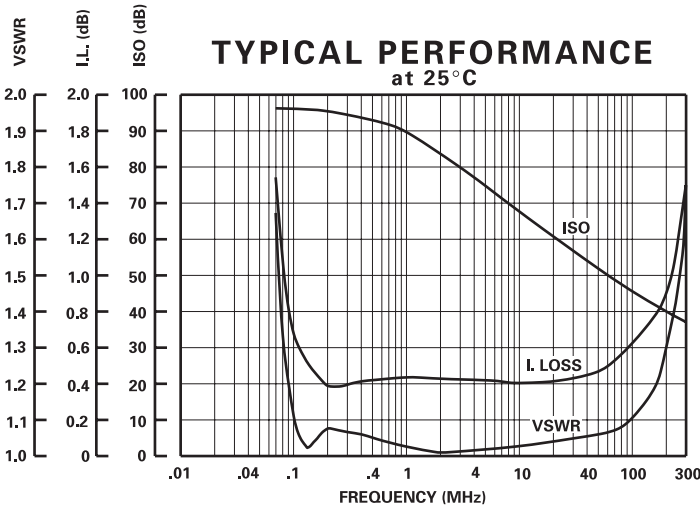
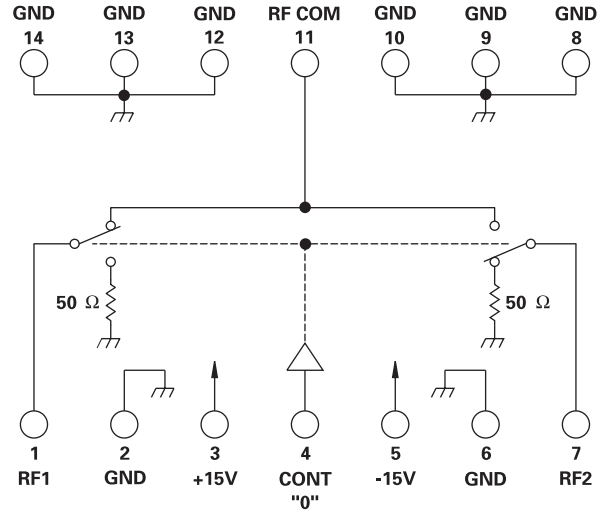
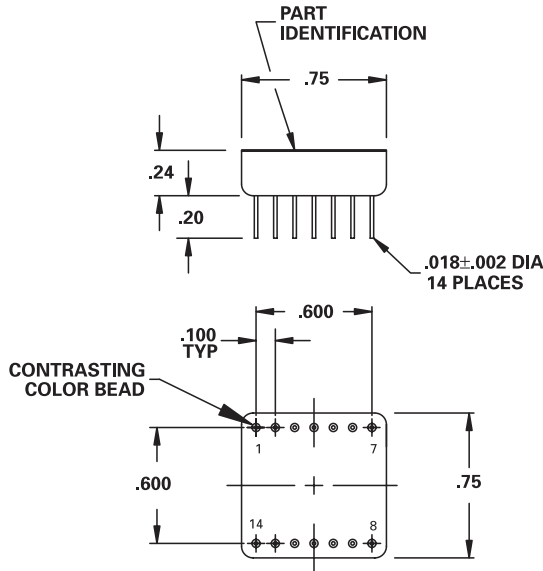

GUARANTEED PERFORMANCE

Parameter	Min	Typ	Max	Units	Conditions	
Operating Frequency	0.5		100	MHz		
DC Current		5	10	mA	At +15 VDC Supply	
		4	5	mA	At -15 VDC Supply	
Control Type		TTL			1 Line Logic "0" = RF COM to RF1 Logic "1" = RF COM to RF2	
Isolation	64	68		dB	10 MHz	
	53	57		dB	30 MHz	
	42	46		dB	100 MHz	
Insertion Loss		0.6	.9	dB		
VSWR		1.1/1	1.25/1			
			1.1/1	1.25/1		
Impedance		50		OHMS		
Switching Speed		5	10	μSEC	50% TTL to 90% / 10% RF	
Transition (Rise/Fall) Time		3.5	5	μSEC	10% / 90% or 90% / 10% RF	
Switching (Video) Transients		10	20	mV	Peak Value	
Intercept Points	2nd	+85	+96	dBm		
	3rd	+50	+58	dBm		
RF Power	Operate		+26	+19	dBm	0.1 dB Compression
	Common Port		+31	+24	dBm	1 dB Compression
Operating Temperature	-55	+25	+125	°C	TA	