

**MODEL NUMBER
DSW22201**

Switch SP2T

- FEATURES**
- 30-400 MHz
 - 0.4 dB Insertion Loss
 - 9 mV Switching Transients
 - TO- Package

SP2T

www.DataSheet4U.com

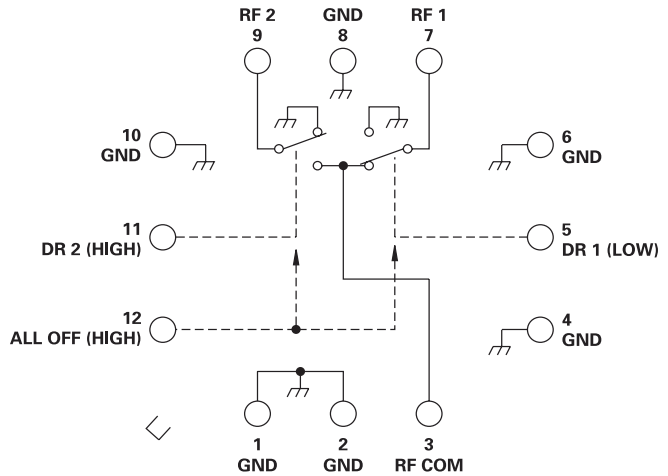
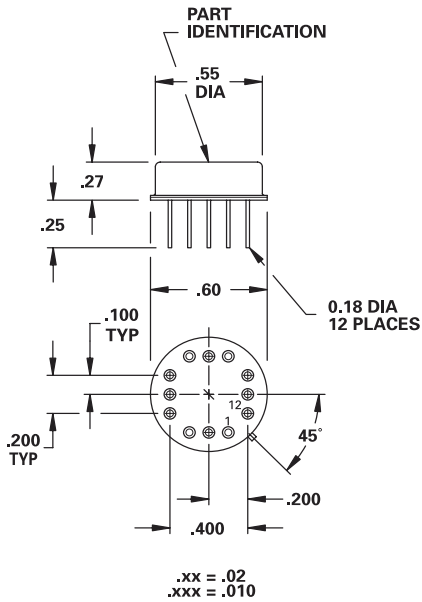

		Voltage	Source Z	Current
Drive (N)	High	+15V	700 Ω	Source ≈ 7.2 mA
	Low	0V	700 Ω	Sink ≈ 7.2 mA
All Off Drive	High	+15V	370 Ω	0 mA
	Low	0V	370 Ω	Sink ≈ 14.4 mA

Selection	Drive 1	All Off	Drive 2
RF 1 (On)	Low	High	High
All Off	High	Low	High
RF 2 (On)	High	High	Low

GUARANTEED PERFORMANCE

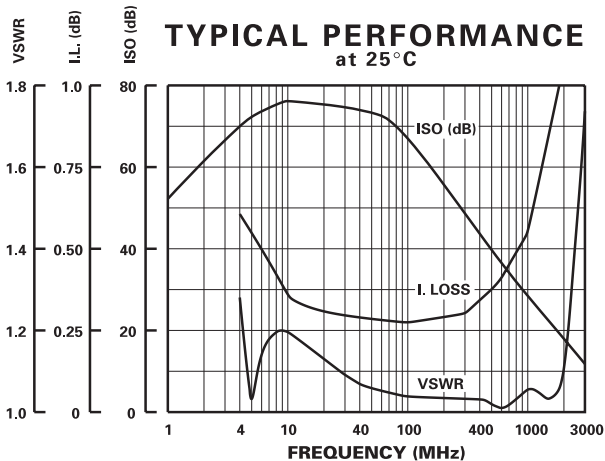

Parameter	Min	Typ	Max	Units	Conditions
Operating Frequency	30		400	MHz	
DC Current				mA	See Table
Control Type		TTL			2 Line, See Table
Control Current				mA	VIH = +15 V VIL = 0 V
		High	7.7		
		Low	0		
		All Off	15.9		
Insertion Loss		0.40	0.46	dB	
Isolation	40	43		dB	
VSWR		1.05/1	1.16/1		
Impedance		50		OHMS	
Switching Speed		78		µSec	50% TTL - 90% / 10% RF
Transition (Rise/Fall) Time		57		µSec	10% / 90% - 90% / 10% RF
Switching (Video) Transients		9		mV	Peak Value
Intercept Points				dBm	52.5 MHz / 27.5 MHz
	2nd	+72			
	3rd	+38			26.25 MHz / 27.5 MHz
RF Power				dBm	.1 dB Compression
	Operate	+21			No Damage
	Maximum	+30			
Operating Temperature	-55	+25	+85	°C	