

Displaytech Ltd.

Website: www.displaytech.com.hk

LCD Module Product Specification

Product: 5.7" TFT Display Module (640RGBx480DOTS)

Contents in this document are subject to change without notice. No part of this document may be reproduced or transmitted in any form or by any means, electronic or mechanical, for any purpose, without the express written permission of Displaytech Ltd.

14 May 2010.

1. REVISION RECORD

VERSION	CHANGES	DATE
1.0	Initial revision	14 May 2010

Table of Content

1. REVISION RECORD..... 1

2. Introduction 3

3. General Specifications 3

4. Mechanical Drawing..... 4

5. Interface Description..... 6

6. Absolute Maximum Ratings..... 7

7. Electrical Characteristics 7

8. Display Controller /Power Supply Timing 7

9. Operational EMC Requirements..... 8

10. Optical Characteristics 8

11. Backlight specification 10

12. Safety Precaution..... 10

2. Introduction

DT057TFT or *DT057TFT-TS* is a display module that contains a TFT display with a 480 * 640 RGB resolution. The drivers used for this project are the Himax **HX8678 and HX8250 or compatible** and can display 16M colors. The drivers are mounted on the glass and the interconnection via FPC including components to drive the display module.

3. General Specifications

Item	Specification	Unit
LCD mode	Transmissive	---
Resolution	640(RGB)	Line
	480	Line
Viewing area	116.8	mm
	88.0	mm
Active area	115.2	mm
	86.4	mm
Driver IC	HX8678 and HX8250	---
Interface type	RGB / Parallel interface	---
Colours	16M	---
Operation temperature (w/o touch screen)	-20~70	°C
Storage temperature (w/o touch screen)	-30~80	°C
Operation temperature (w touch screen)	-10~60	°C
Storage temperature (w touch screen)	-20~70	°C

Remarks:

- (1) Serial interface is available, but not recommendable, as the speed of it is very slow.
- (2) Recommended mating connector: Hirose FH19SC-45S-0.5SH, FH12S-45S-0.5SH; or Molex 0512964593, 0512964594; or equivalent

Component Life Cycle

- 1) Storage Life: min. 1 Year
- 2) Operation Life (*1): min. 43 x 10³ h (24h per day x 7 days per week x 52 weeks / year x 5 years)
(Not include backlight)
- 3) Storage and Operation Life Times are defined for a temperature of +25°C

Notes:

*1. Operation life ends when one of the listed faults occurs:

- The on/off response-times reach 1.5 times of the max. value specified for a new display
- The contrast is reduced to 0.5 of the original contrast value
- Loss of function
- The number of cosmetic defects exceeds the maximum defined

4. Mechanical Drawing

4.1. DT057TFT

REV.	DESCRIPTIONS	DWN.	APPD.	DATE
------	--------------	------	-------	------

PIN ASSIGNMENT

NO.	Pin name	NO.	Pin name
1	GND	24	B05
2	NPC(OUTPUT)	25	B06
3	R00	26	B07
4	R01	27	CLK
5	R02	28	VS
6	R03	29	HS
7	R04	30	DEN
8	R05	31	SPENA
9	R06	32	SPCK
10	R07	33	SPDA
11	G00	34	RESETB
12	G01	35	UD
13	G02	36	LR
14	G03	37	VDD
15	G04	38	VDD
16	G05	39	GND
17	G06	40	NC
18	G07	41	NC
19	B00	42	NC
20	B01	43	NC
21	B02	44	LEDA
22	B03	45	LEDK
23	B04		

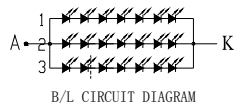
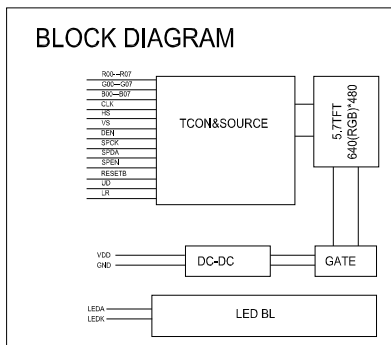
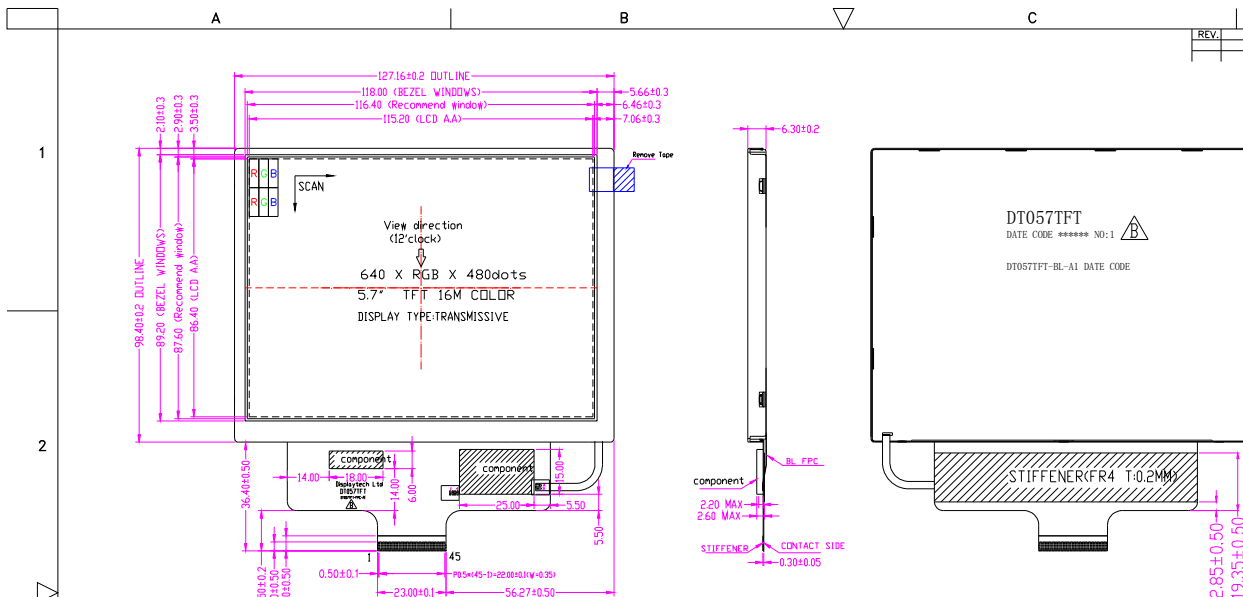

- NOTES:
1. OPERATING TEMP: -20° C TO 70° C
 2. STORAGE TEMP : -30° C TO 80° C
 3. Backlight: WHITE PATENT LED
 4. VDD=3.3V
 5. IC: 1*(HX8678-B)+2*(HX8250-A)
 6. ROHS COMPLIANCE
 7. GENERAL TOLERANCE: ±0.2

PROJECTION

Displaytech Ltd

SCALE	DRAWN BY	DATE	18MAR10
SHT#	APP. BY	DATE	
DWG. DT057TFT ASSEMBLY			
PROJ#	DWG#	REV.	B
MODEL#	REV.	B	DATE
RELEASE TO:			

ALL ARE PRODUCT DIMENSIONS, UNLESS OTHERWISE SPECIFIED. ALL DIMENSIONS ARE IN mm (INCHES) AND TOLERANCES

.xxx .xx ANGULAR
± 0.20 ±

DO NOT SCALE DRAWING

4.2. DT057TFT-TS

REV.	DESCRIPTIONS	DWN.	APPD.	DATE

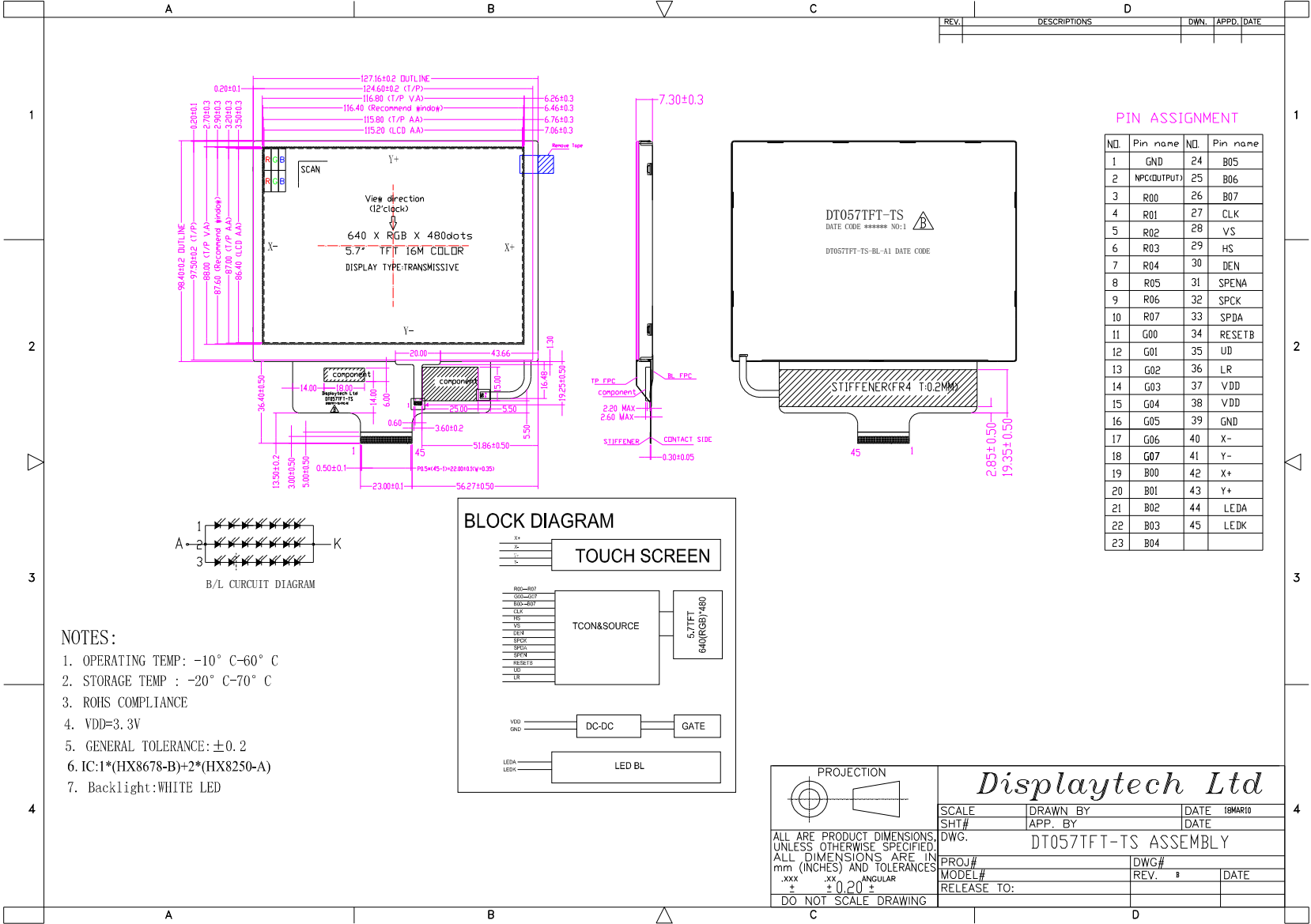

PIN ASSIGNMENT

NO.	Pin name	NO.	Pin name
1	GND	24	B05
2	NPCC(OUTPUT)	25	B06
3	R00	26	B07
4	R01	27	CLK
5	R02	28	VS
6	R03	29	HS
7	R04	30	DEN
8	R05	31	SPENA
9	R06	32	SPCK
10	R07	33	SPDA
11	G00	34	RESETB
12	G01	35	UD
13	G02	36	LR
14	G03	37	VDD
15	G04	38	VDD
16	G05	39	GND
17	G06	40	X-
18	G07	41	Y-
19	B00	42	X+
20	B01	43	Y+
21	B02	44	LEDA
22	B03	45	LEDK
23	B04		

NOTES:

1. OPERATING TEMP: -10° C-60° C
2. STORAGE TEMP : -20° C-70° C
3. ROHS COMPLIANCE
4. VDD=3.3V
5. GENERAL TOLERANCE: ±0.2
6. IC:1*(HX8678-B)+2*(HX8250-A)
7. Backlight:WHITE LED

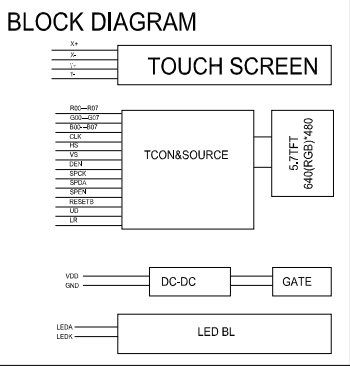

PROJECTION

ALL ARE PRODUCT DIMENSIONS, UNLESS OTHERWISE SPECIFIED. ALL DIMENSIONS ARE IN mm (INCHES) AND TOLERANCES

.xxx	.xx	ANGULAR
+	±	0.20 ±

DO NOT SCALE DRAWING

Displaytech Ltd

SCALE	DRAWN BY	DATE	DMARIO
SHT#	APP. BY	DATE	
DWG. DT057TFT-TS ASSEMBLY			
PROJ#	DWG#	REV.	DATE
MODEL#			
RELEASE TO:			

5

5. Interface Description

Pin no	Symbol	Level	Description
1	GND	0V	Ground
2	NPC (output)	H/L	NTSC or PAL mode auto detection result. When NPC=H, NTSC mode is selected. When NPC=L, PAL mode is selected, in above case is output. (advice this pin should not connection)
3~10	R00 ~ R07	H/L	Digital data input.
11~18	G00 ~ G07	H/L	Digital data input.
19~26	B00 ~ B07	H/L	Digital data input.
27	CLK	H/L	Clock signal. Latching data at the rising edge.
28	VS	H/L	Vertical sync input in digital RGB and CCIR601 mode. (Short to GND if not used)
29	HS	H/L	Horizontal sync input in digital RGB and CCIR601 mode. (Short to GND if not used)
30	DEN	H/L	Input data enable control. When DE mode, active High to enable data input. Normally pull low.
31	SPENA	H/L	Serial port Data Enable Signal. Normally pull high.
32	SPCK	H/L	Serial port Clock. Normally pull high.
33	SPDA	H/L	Serial port Data input/output. Normally pull high.
34	RESETB	H/L	Hardware global reset. Low active. Normally pull high.
35	UD	H/L	Up/down scan setting. When UD=H, reverse scan. When UD=L, normal scan.
36	LR	H/L	The shift direction of device internal shift register is controlled by this pin as shown below: LR=H:STH"SO1"..."SO960"STHO LR=L:STH"SO960"..."SO1"STHO
37~38	VDD	2.7~3.6V	Power supply.
39	GND	0V	Ground
40	X-	---	Touch screen pin (only for DT057TFT-TS)
41	Y-	---	Touch screen pin (only for DT057TFT-TS)
42	X+	---	Touch screen pin (only for DT057TFT-TS)
43	Y+	---	Touch screen pin (only for DT057TFT-TS)
44	LEDA	---	LED Backlight anode
45	LEDK	---	LED Backlight cathode

6. Absolute Maximum Ratings

Item	Symbol	Rating	Unit
Supply voltage range	V _{DD}	-0.3 to +7.0	V
Input voltage range	V _{in}	-0.3 to V _{DD} + 0.3	V
Operating Ambient Temperature (DT057TFT)	T _{OP}	-20 ~ +70	°C
Operating Ambient Temperature (DT057TFT-TS)	T _{OP}	-10 ~ +60	°C
Operating Ambient Humidity	H _{OP}	10 ~ 90 (Max 60°C)	% RH
Storage Temperature (DT057TFT)	T _{STG}	-30 ~ +80	°C
Storage Temperature (DT057TFT-TS)	T _{STG}	-20 ~ +70	°C
Storage Humidity	H _{STG}	10 ~ 90 (Max 60°C)	% RH

7. Electrical Characteristics

DC Characteristics

Item	Symbol	Rating	Unit
Power supply	V _{DD}	2.7 min; 3.3 typ; 3.6 max	V
Input current	I _{DD}	145 typ; 290 max	mA
Input voltage "H"	V _{IH}	0.7 V _{DD} to V _{DD}	V
Input voltage "L"	V _{IL}	0 to 0.3 V _{DD}	V
Output voltage "H"	V _{OH}	0.7 V _{DD} to V _{DD}	V
Output voltage "L"	V _{OL}	0 to 0.2 V _{DD}	V

8. Display Controller /Power Supply Timing

See Display Controller Specification: **Himax HX8678 and HX8250**

9. Operational EMC Requirements

The operational EMC immunity requirements and emission limits for DISPLAYTECH modules are provided in table 1: EMC specification for operational modules.

Table 1. EMC specification for operational modules

EMC phenomena	REFERENCE standard	Frequency range	Level/ Limit	Test specification	Performance criteria
Electromagnetic field	IEC 61000-4-3	30MHz-1000MHz	3 V/m	1kHz sine, 80% AM	C
EFT/Burst	IEC 61000-4-4	n.a.	10 V	-8us/50us -10ns/100ns	C C
Electrostatic Discharge*	IEC61000-4-2	n.a.	4 kV/ 8 kV	Contact/ Air	C
Conducted RF signals	IEC 61000-4-6	150kHz-30MHz	1 V	1kHz sine, 80% AM	C
Radiated emission	IEC 61000-6-4	30 MHz-1000MHz	47 dBuV	d = 10 m	n.a.

After a charge of 4kV, the display module is allowed to go down for 2 seconds and need to comeback again. With 8kV the display module is allowed to go down and has to comeback after a reset.

10. Optical Characteristics

Item	Symbol	Condition	Min	Typ	Max	Unit	Remark	Note
Response Time	Tr + Tf	θ=0° Ø=0° Ta=25°C	---	45.7	68.6	ms	Fig 2	4
Contrast ratio	Cr		300	656	---	---		1
Luminance Uniformity	δ White		80	89	---	%		3
Surface Luminance	Lv		232	290	---	cd/m ²		2
Viewing Angle range	θ	Ø=90°	70	80	---	deg	Fig 1	6
		Ø=270°	66	76	---			
		Ø=0°	69	79	---			
		Ø=180°	57	67	---			
NTSC ratio	---	---	44	50	---	%		
CIE (x,y) Chromaticity	Red	x	0.5513	0.6013	0.6513			5
		y	0.3156	0.3656	0.4156			
	Green	x	0.3037	0.3537	0.4037			
		y	0.5027	0.5707	0.6207			
	Blue	x	0.0955	0.1455	0.1955			
		y	0.0526	0.1026	0.1526			
	White	x	0.2618	0.3218	0.3818			
		y	0.2883	0.3483	0.4083			

Note 1: Contrast Ratio = $\frac{\text{Average Surface Luminance with all white pixels (P}_1, P_2, P_3, P_4, P_5)}{\text{Average Surface Luminance with all black pixels (P}_1, P_2, P_3, P_4, P_5)}$

Note 2: Surface luminance is the LCD surface from the surface with all pixels displaying white.
 $L_v = \text{Average Surface Luminance with all white pixels (P}_1, P_2, P_3, P_4, P_5)$

Note 3: The uniformity in surface luminance, δ WHITE is determined by measuring luminance at each test position 1 through 5, and then dividing the maximum luminance of 5 points luminance by minimum luminance of 5 points luminance.
 $\delta \text{ WHITE} = \frac{\text{Minimum Surface Luminance with all white pixels (P}_1, P_2, P_3, P_4, P_5)}{\text{Maximum Surface Luminance with all white pixels (P}_1, P_2, P_3, P_4, P_5)}$

Note 4: Response time is the time required for the display to transition from White to black (Rise Time, T_r) and from black to white (Decay Time, T_f). For additional information see FIG 2.

Note 5: CIE (x, y) chromaticity: The x,y value is determined by measuring luminance at each test position 1 through 5, and then taking average value

Note 6: Viewing angle is the angle at which the contrast ratio is greater than 2. For TFT module the contrast ratio is greater than 10. The angles are determined for the horizontal or x axis and the vertical or y axis with respect to the z axis which is normal to the LCD surface. For additional information see Fig 1.

Fig.1 (Definition of Viewing Angle)

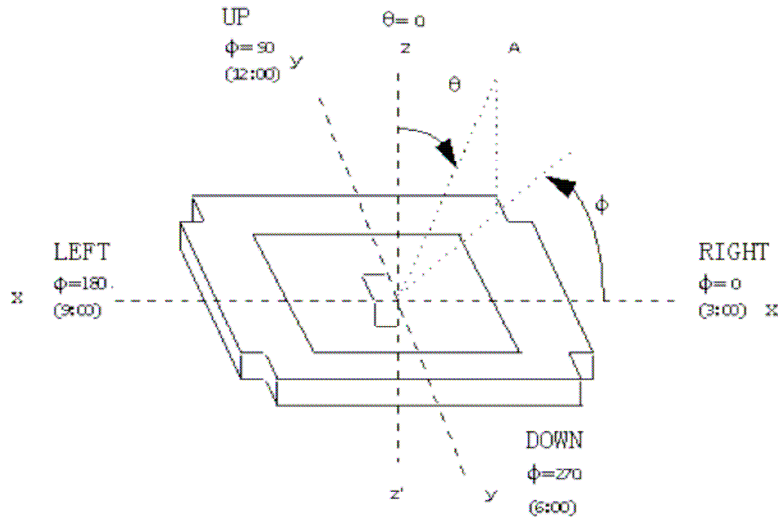
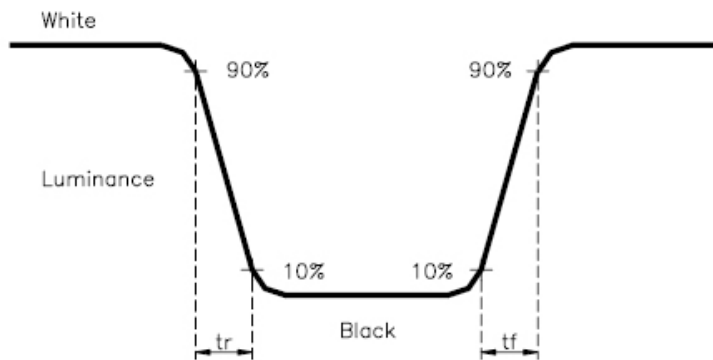

Fig. 2 (The response time is defined as the time interval between the 10% and 90% amplitudes. Refer to figure below.)



11.Backlight specification

ITEM	PARAMETER	UNIT
COLOR	WHITE	
AVERAGE LUMINOUS INTENSITY (LV)	4800 to 6600 (IF 60mA)	cd/m ²
NO.OF LED SMT	7x3	---
FORWARD VOLTAGE (VF)	22.2 (IF 60mA)	V

12.Safety Precaution

Handling precautions:

- This device is susceptible to Electro-Static Discharge (ESD) damage. Observe Anti-Static precautions.

Power supply precautions:

- Identify and, at all times, observe absolute maximum ratings for both logic and LC drivers. Note that there is some variance between models.
- Prevent the application of reverse polarity to VCC and GND, however briefly.
- Use a clean power source free from transients. Power up conditions are occasionally “jolting” and may exceed the maximum ratings of the modules.
- The VCC power of the module should also supply the power to all devices that may access the display. Don’t allow the data bus to be driven when the logic supply to the module is turned off.

Operating precautions:

- DO NOT plug or unplug the module when the system is powered up.
- Minimize the cable length between the module and host MPU.
- Operate the module within the limits of the modules temperature specifications.

Mechanical/Environmental precautions:

- Improper soldering is the major cause of module difficulty. Use of flux cleaner is not recommended as they may seep under the elastomeric connection and cause display failure.
- Mount the module so that it is free from torque and mechanical stress.
- Surface of the LCD panel should not be touched or scratched. The display front surface is an easily scratched, plastic polarizer. Avoid contact and clean only when necessary with soft, absorbent cotton dampened with petroleum benzene.
- Always employ anti-static procedure while handling the module.
- Prevent moisture build-up upon the module and observe the environmental constraints for storage temperature and humidity.
- Do not store in direct sunlight
- If leakage of the liquid crystal material should occur, avoid contact with this material, particularly ingestion. If the body or clothing becomes contaminated by the liquid crystal material, wash thoroughly with water and soap