

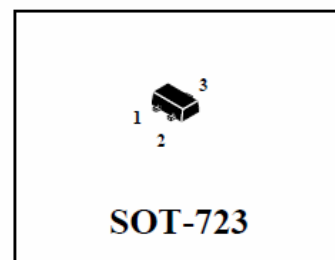

**Bias Resistor Transistor PNP Silicon**

**(Pb)** Lead(Pb)-Free

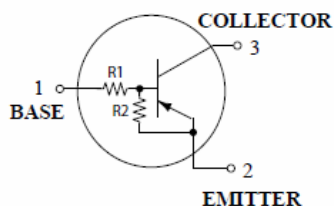

**Maximum Ratings** (TA=25°C unless otherwise noted)

Rating	Symbol	Value	Unit
Collector-Base Voltage	V <sub>CB0</sub>	50	V
Collector-Emitter Voltage	V <sub>CEO</sub>	50	V
Collector Current-Continuous	I <sub>C</sub>	100	mA

**Thermal Characteristics**

Characteristics	Symbol	Max	Unit
Total Device Dissipation FR-5 Board FR-4 Board <sup>(1)</sup> T <sub>A</sub> =25°C Derate above 25°C	P <sub>D</sub>	260 2.0	mW mW/°C
Thermal Resistance, Junction to Ambient <sup>(1)</sup>	R <sub>θJA</sub>	480	°C/W
Total Device Dissipation FR-5 Board FR-4 Board <sup>(2)</sup> T <sub>A</sub> =25°C Derate above 25°C	P <sub>D</sub>	600 4.8	mW mW/°C
Thermal Resistance, Junction to Ambient <sup>(2)</sup>	R <sub>θJA</sub>	205	°C/W
Junction Temperature Range	T <sub>J</sub>	-55 to +150	°C
Storage Temperature Range	T <sub>stg</sub>	-55 to +150	°C

- 1. FR-4 @ Minimum pad
- 2. FR-4 @1.0 x 1.0 Inch pad

**Device Marking and Resistor Values**

Device	Marking	R1(K)	R2(K)
DTA114EM	6A	10	10
DTA124EM	6B	22	22
DTA144EM	6C	47	47
DTA114YM	6D	10	47
DTA114TM	6E	10	∞
DTA143TM	6F	4.7	∞
DTA123EM	6H	2.2	2.2

Device	Marking	R1(K)	R2(K)
DTA143EM	6J	4.7	4.7
DTA143ZM	6K	4.7	47
DTA124XM	6L	22	47
DTA123JM	6M	2.2	47
DTA115EM	6N	100	100
DTA144WM	6P	47	22



**Electrical Characteristics** ( $T_A = 25^\circ\text{C}$  unless otherwise noted) (Continued)

Characteristic	Symbol	Min	Typ	Max	Unit
Input Resistor	DTA114EM	7.0	10	13	k $\Omega$
	DTA124EM	15.4	22	28.6	
	DTA144EM	32.9	47	61.1	
	DTA114YM	7.0	10	13	
	DTA114TM	7.0	10	13	
	DTA143TM	3.3	4.7	6.1	
	DTA123EM	1.5	2.2	2.9	
	DTA143EM	3.3	4.7	6.1	
	DTA143ZM	3.3	4.7	6.1	
	DTA124XM	15.4	22	28.6	
	DTA123JM	1.54	2.2	2.86	
	DTA115EM	70	100	130	
	DTA144WM	32.9	47	61.1	
Resistor Ratio	$R_1/R_2$	DTA114EM/DTA124EM/DTA144EM	0.8	1.0	1.2
		DTA115EM	0.17	0.21	0.25
		DTA114YM	-	-	-
		DTA114TM/DTA143TM/DTA143EM	0.8	1.0	1.2
		DTA123EM	0.055	0.1	0.185
		DTA143ZM	0.38	0.47	0.56
		DTA124XM	0.038	0.047	0.056
		DTA123JM	1.7	2.1	2.6
		DTA144WM			

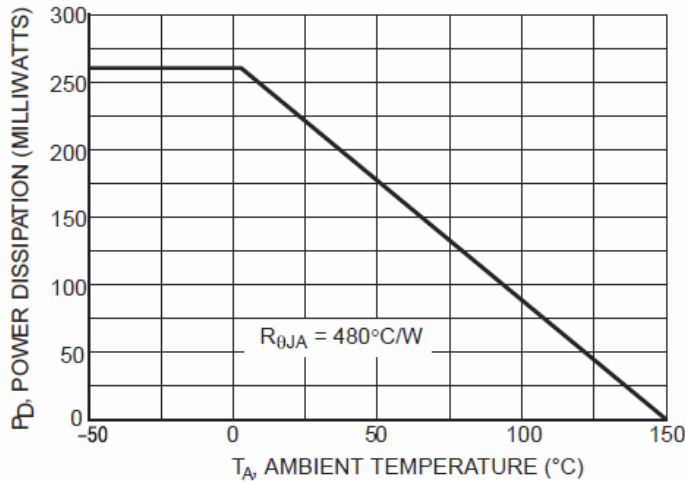

Figure 1. Derating Curve

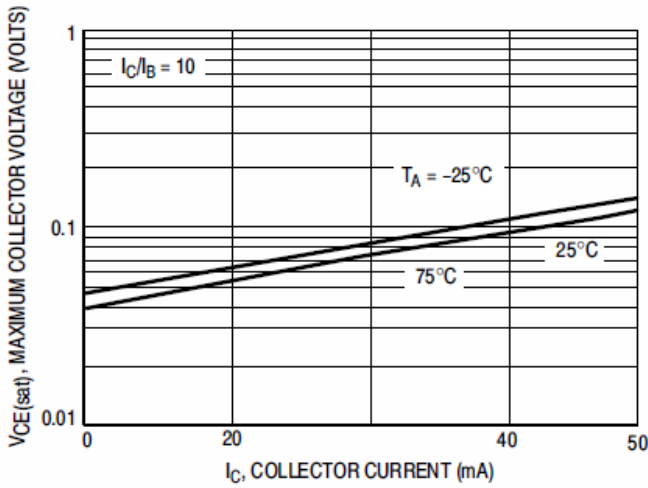

Figure 2.  $V_{CE(sat)}$  versus  $I_C$

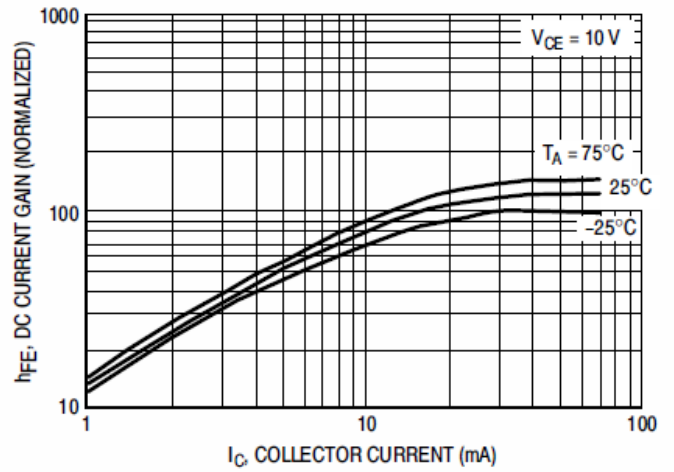

Figure 3. DC Current Gain

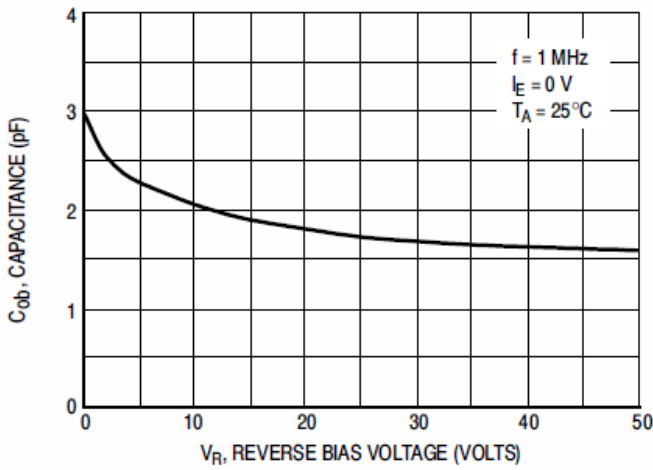

Figure 4. Output Capacitance

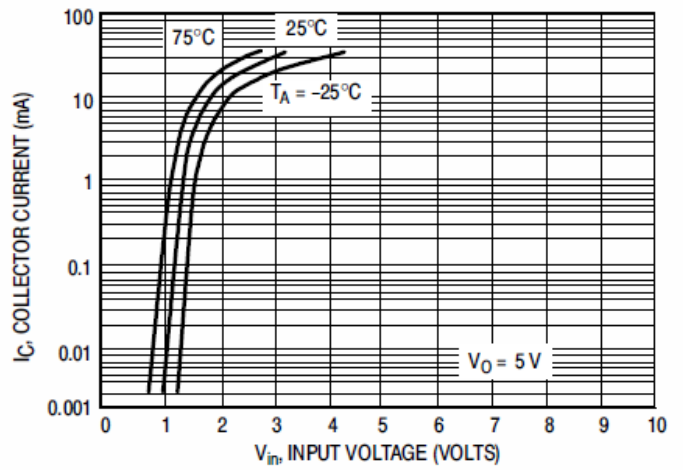

Figure 5. Output Current versus Input Voltage

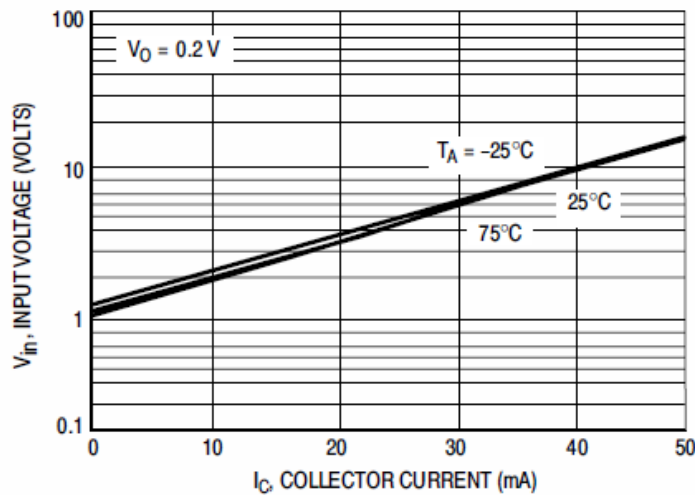

Figure 6. Input Voltage versus Output Current

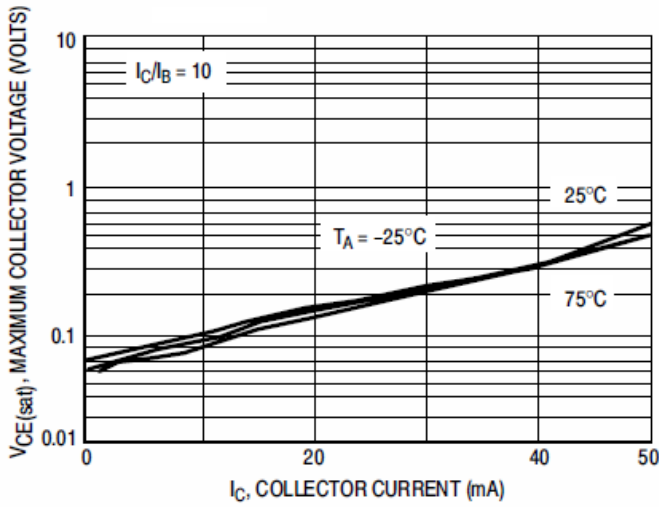

Figure 7.  $V_{CE(sat)}$  versus  $I_C$

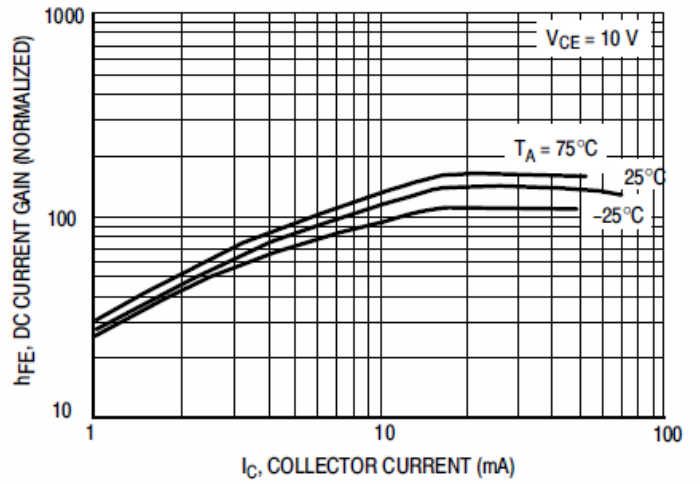

Figure 8. DC Current Gain

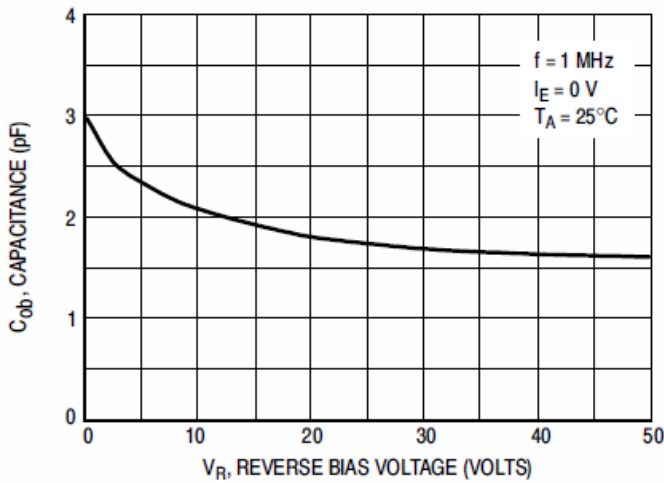

Figure 9. Output Capacitance

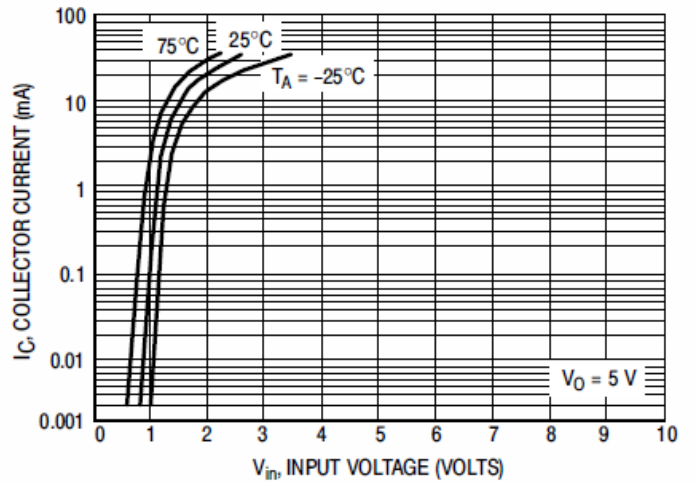

Figure 10. Output Current versus Input Voltage

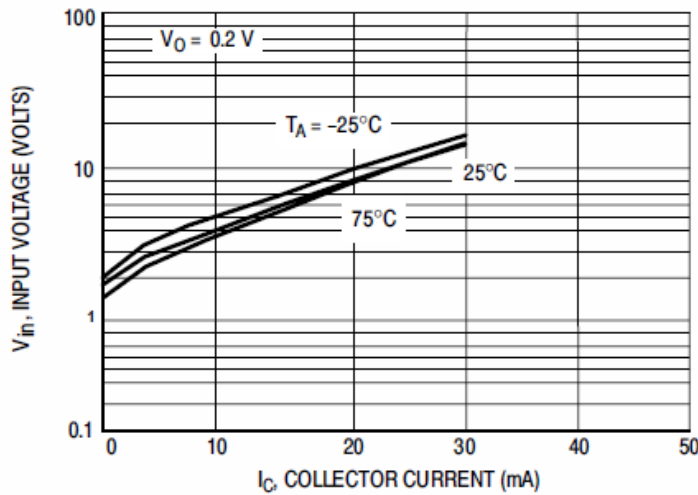

Figure 11. Input Voltage versus Output Current

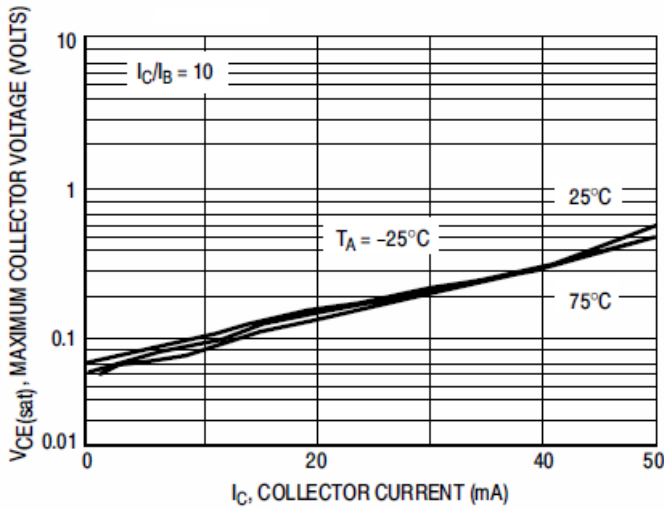

Figure 7.  $V_{CE(sat)}$  versus  $I_C$

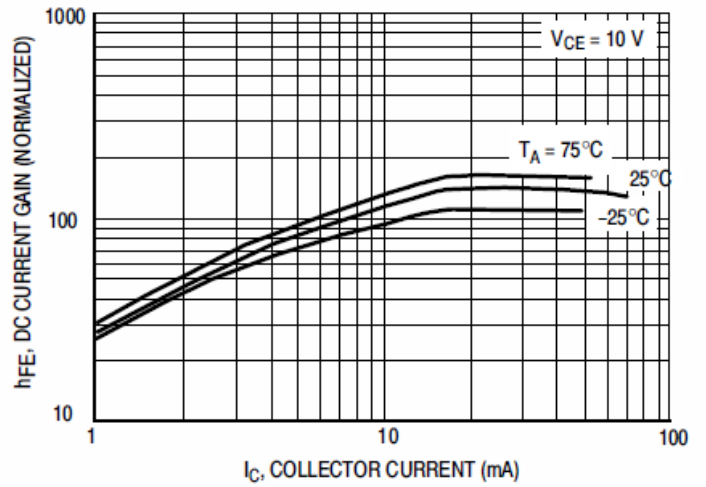

Figure 8. DC Current Gain

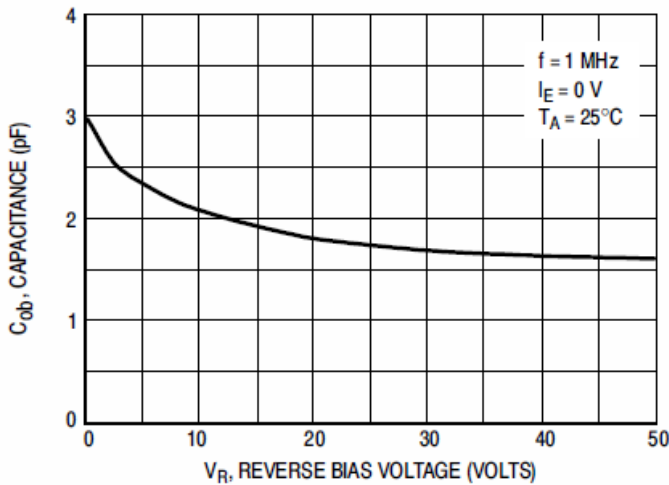

Figure 9. Output Capacitance

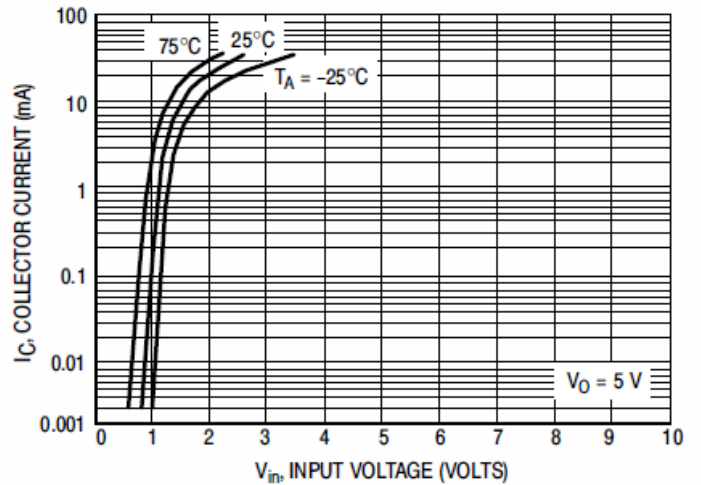

Figure 10. Output Current versus Input Voltage

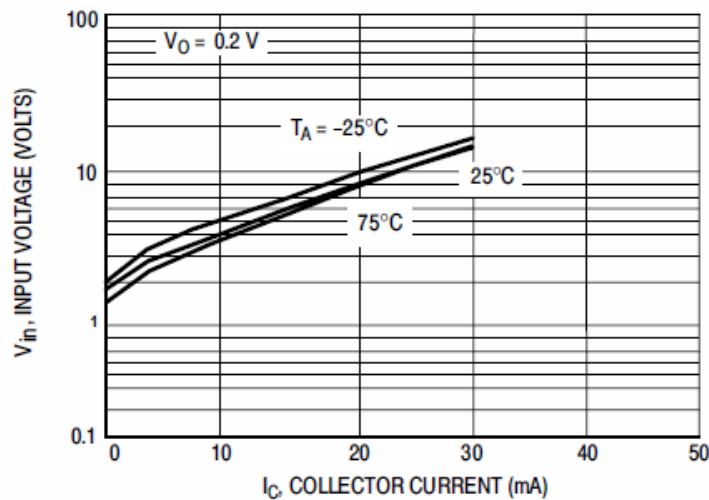

Figure 11. Input Voltage versus Output Current

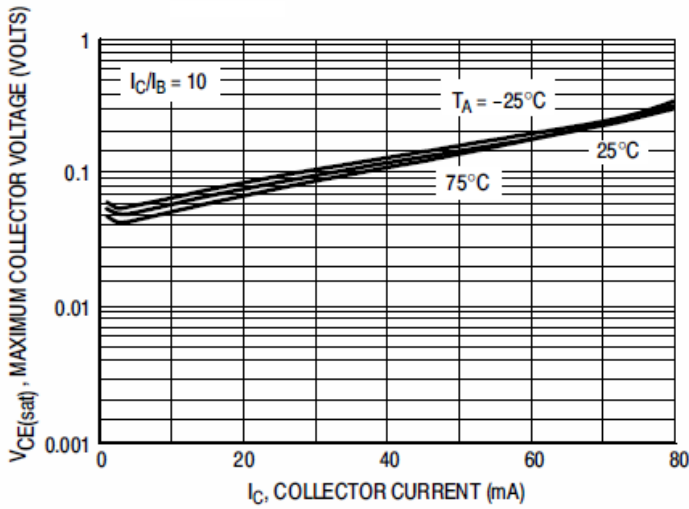

Figure 17.  $V_{CE(sat)}$  versus  $I_C$

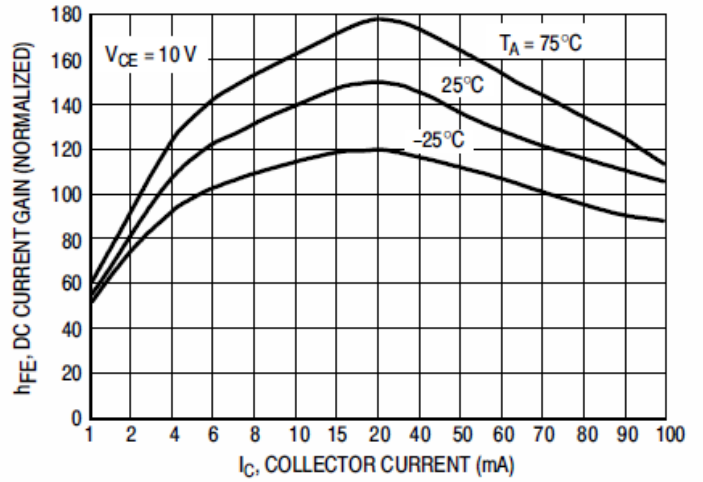

Figure 18. DC Current Gain

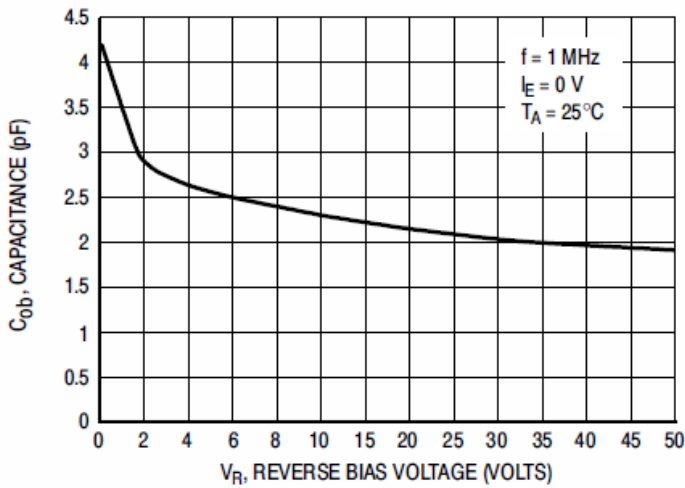

Figure 19. Output Capacitance

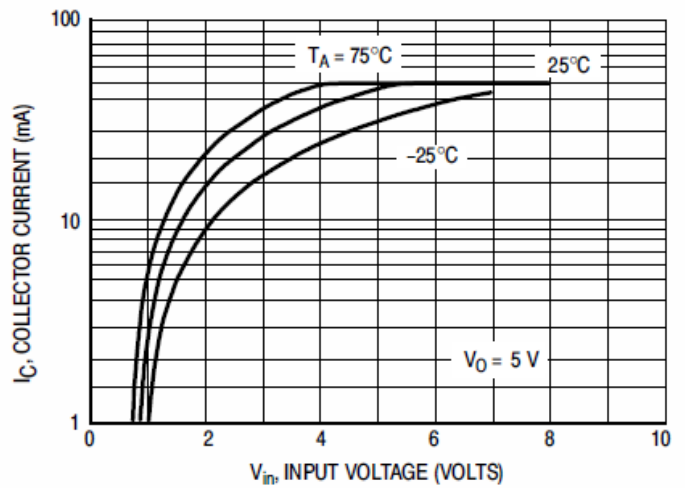

Figure 20. Output Current versus Input Voltage

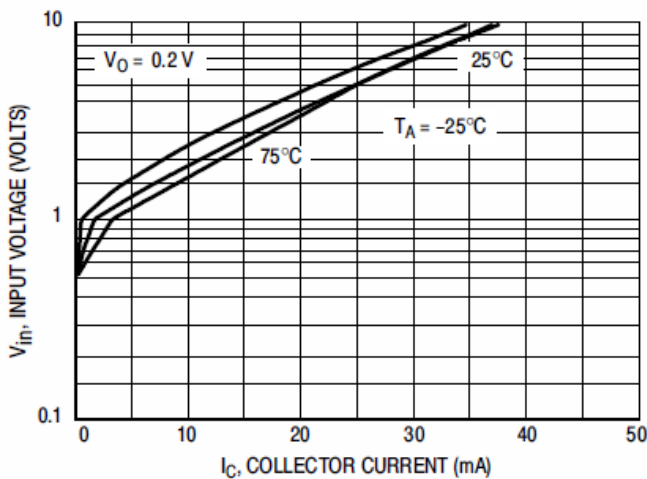

Figure 21. Input Voltage versus Output Current

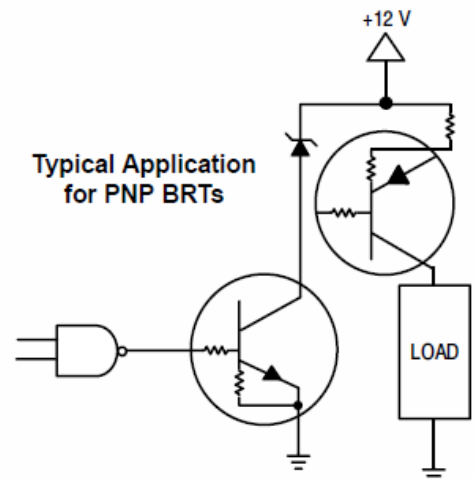

Figure 22. Inexpensive, Unregulated Current Source



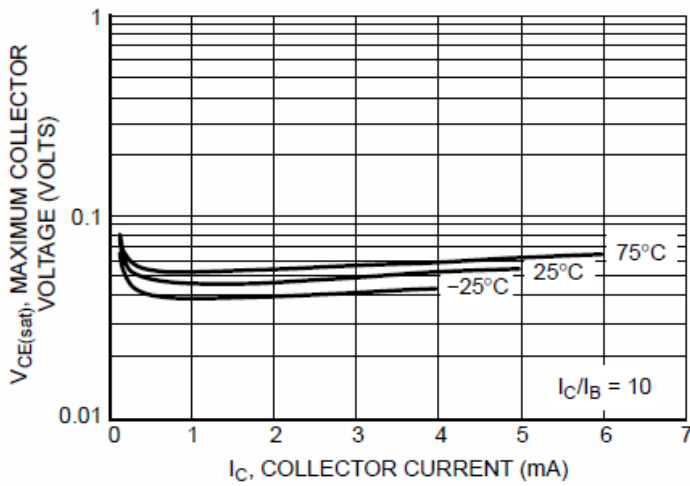

Figure 23. Maximum Collector Voltage versus Collector Current

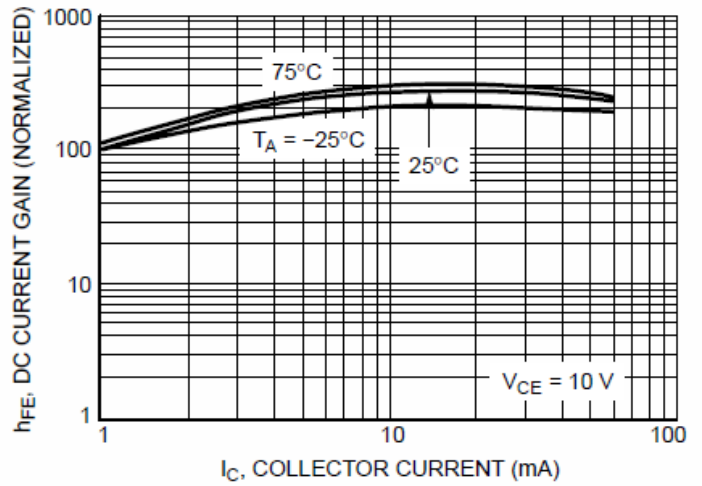

Figure 24. DC Current Gain

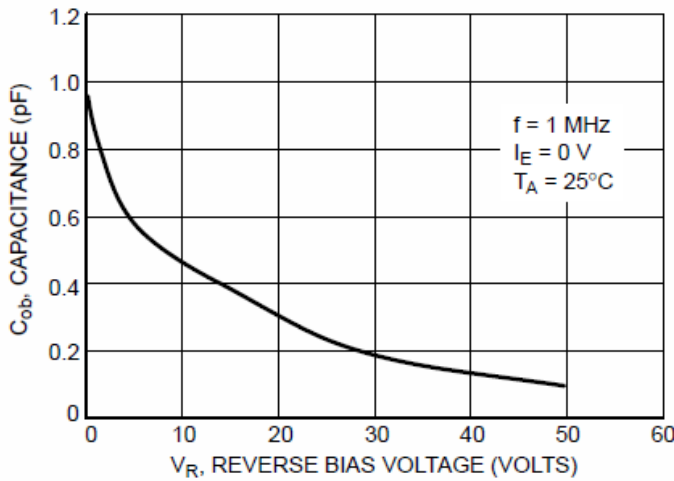

Figure 25. Output Capacitance

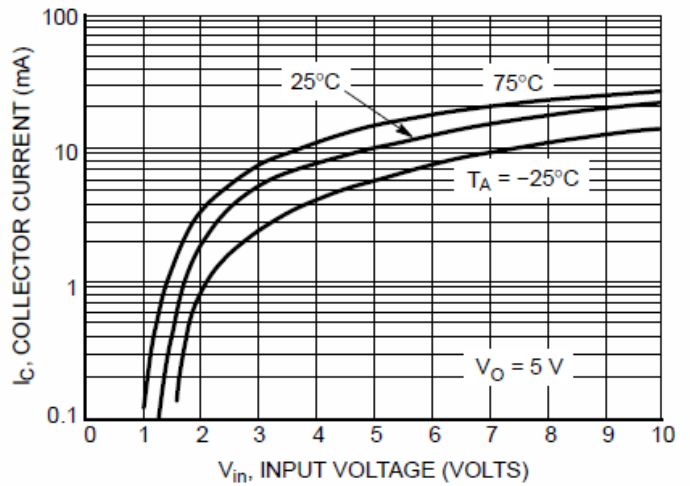

Figure 26. Output Current versus Input Voltage

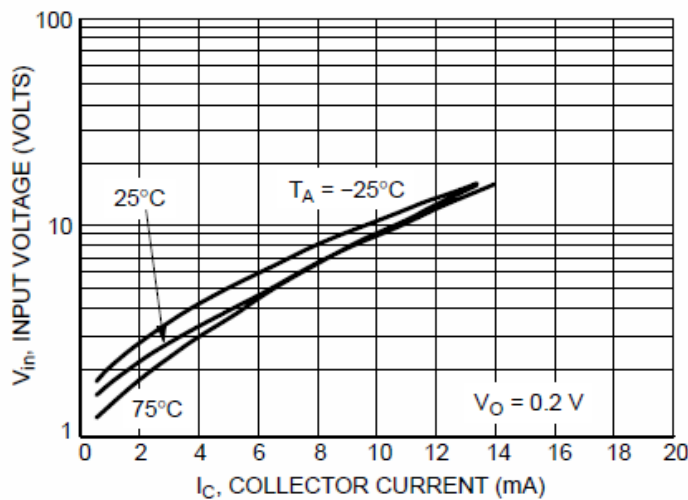

Figure 27. Input Voltage versus Output Current



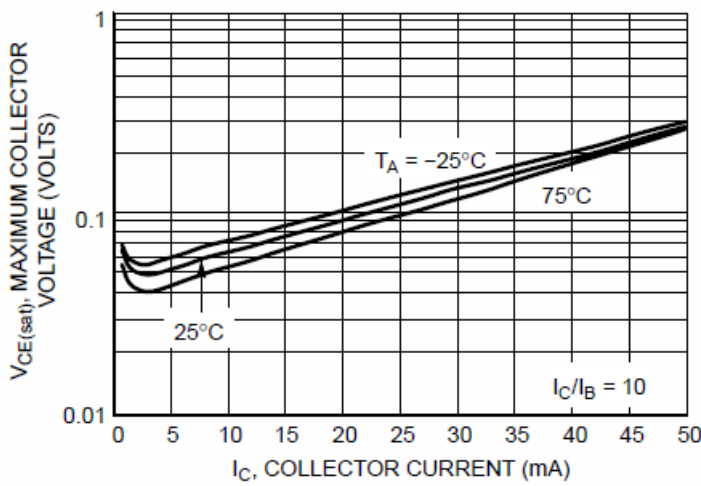

Figure 28. Maximum Collector Voltage versus Collector Current

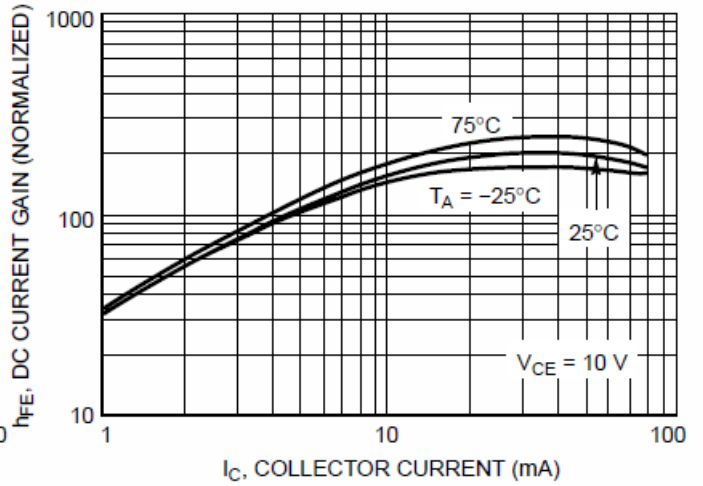

Figure 29. DC Current Gain

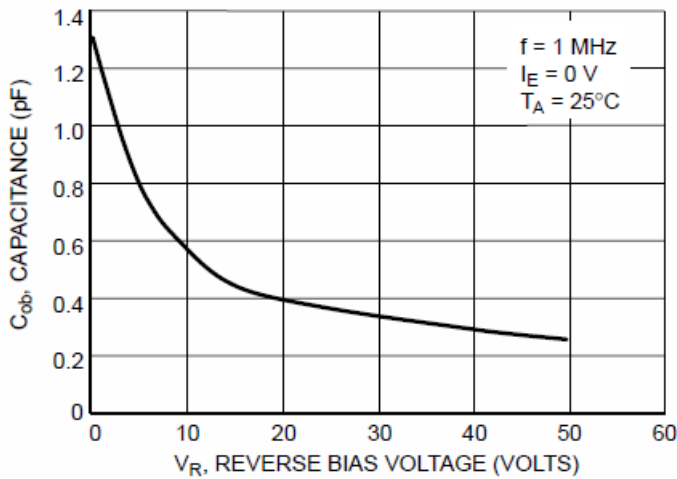

Figure 30. Output Capacitance

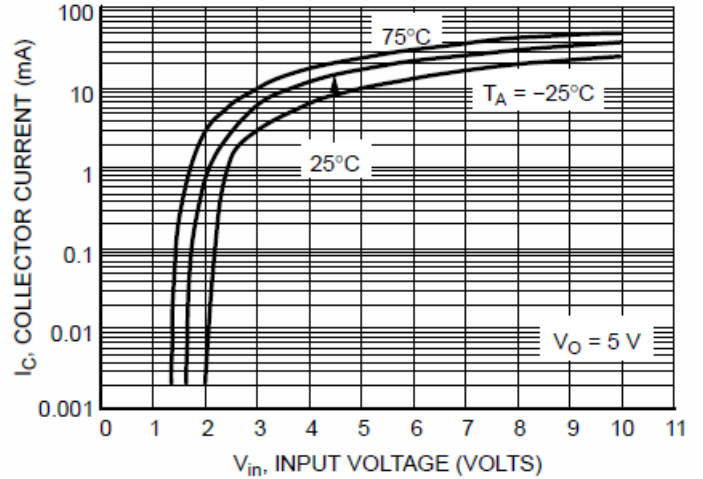

Figure 31. Output Current versus Input Voltage

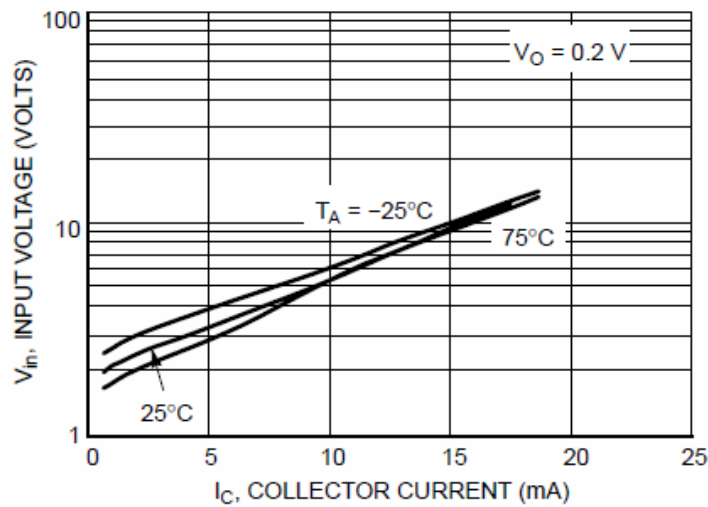
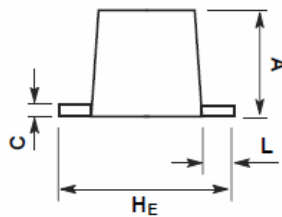
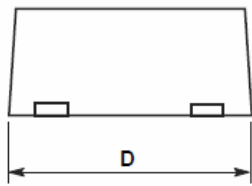
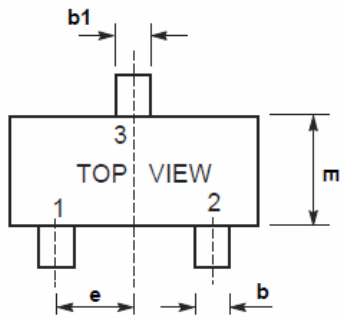

Figure 32. Input Voltage versus Output Current



### SOT-723 Outline Demensions

Unit:mm



SOT-723			
Dim	Min	Nom	Max
A	0.45	0.50	0.55
b	0.15	0.20	0.27
b1	0.25	0.3	0.35
C	0.07	0.12	0.17
D	1.15	1.20	1.25
E	0.75	0.80	0.85
e	0.40 BSC		
HE	1.15	1.20	1.25
L	0.15	0.20	0.25

### SOLDERING FOOTPRINT

Unit:mm

