



DTA115T

PNP SILICON TRANSISTOR

DIGITAL TRANSISTORS (BUILT-IN BIAS RESISTORS)

■ FEATURES

- * Built-in bias resistors that implies easy ON/OFF applications.
- * The bias resistors are thin-film resistors with complete isolation to allow positive input.

■ EQUIVALENT CIRCUIT

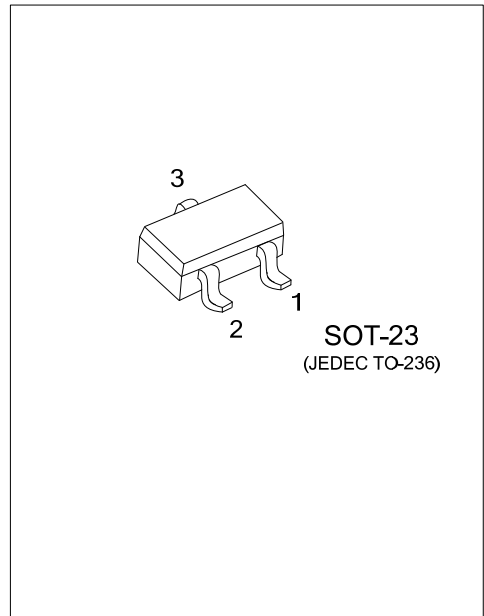
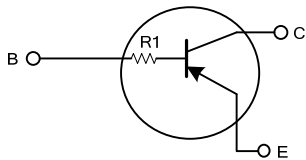

■ ORDERING INFORMATION

Ordering Number	Package	Pin Assignment			Packing
		1	2	3	
DTA115TG-AE3-R	SOT-23	E	B	C	Tape Reel

Note: Pin Assignment: E: Emitter B: Base C: Collector

<p>DTA115TG-AE3-R</p> <p>(1)Packing Type (2)Package Type (3)Green Package</p>	<p>(1) R: Tape Reel (2) AE3: SOT-23 (3) G: Halogen Free and Lead Free</p>
---	---

■ MARKING

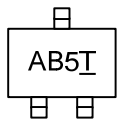

■ ABSOLUTE MAXIMUM RATINGS ($T_A=25^\circ\text{C}$, unless otherwise specified)

PARAMETER	SYMBOL	RATING	UNIT
Collector-Base Voltage	V_{CBO}	-50	V
Collector-Emitter Voltage	V_{CEO}	-50	V
Emitter-Base Voltage	V_{EBO}	-5	V
Collector Current	I_C	-100	mA
Collector Power Dissipation	P_C	200	mW
Junction Temperature	T_J	+150	$^\circ\text{C}$
Storage Temperature	T_{STG}	-55~+150	$^\circ\text{C}$

Note Absolute maximum ratings are those values beyond which the device could be permanently damaged. Absolute maximum ratings are stress ratings only and functional device operation is not implied.

■ ELECTRICAL SPECIFICATIONS ($T_A=25^\circ\text{C}$, unless otherwise specified)

PARAMETER	SYMBOL	TEST CONDITIONS	MIN	TYP	MAX	UNIT
Collector-Base Breakdown Voltage	BV_{CBO}	$I_C=-50\mu\text{A}$	-50			V
Collector-Emitter Breakdown Voltage	BV_{CEO}	$I_C=-1\text{mA}$	-50			V
Emitter-Base Breakdown Voltage	BV_{EBO}	$I_E=-50\mu\text{A}$	-5			V
Collector-Emitter Saturation Voltage	$V_{CE(SAT)}$	$I_C=-1\text{mA}$, $I_B=-0.1\text{mA}$			-0.3	V
Collector Cutoff Current	I_{CBO}	$V_{CB}=-50\text{V}$			-0.5	μA
Emitter Cutoff Current	I_{EBO}	$V_{EB}=-4\text{V}$			-0.5	μA
DC Current Gain	h_{FE}	$V_{CE}=-5\text{V}$, $I_C=-1\text{mA}$	100	250	600	
Input Resistance	R_1		70	100	130	k Ω
Transition Frequency	f_T	$V_{CE}=-10\text{V}$, $I_E=5\text{mA}$, $f=100\text{MHz}$ (Note)		250		MHz

Note: Transition frequency of the device

UTC assumes no responsibility for equipment failures that result from using products at values that exceed, even momentarily, rated values (such as maximum ratings, operating condition ranges, or other parameters) listed in products specifications of any and all UTC products described or contained herein. UTC products are not designed for use in life support appliances, devices or systems where malfunction of these products can be reasonably expected to result in personal injury. Reproduction in whole or in part is prohibited without the prior written consent of the copyright owner. The information presented in this document does not form part of any quotation or contract, is believed to be accurate and reliable and may be changed without notice.