

PROJECTED CAPACITIVE TOUCH PANEL

Product Specification

CUSTOMER		
PRODUCT NUMBER	DTC101-200-00	
CUSTOMER APPROVAL		Date

INTERNAL APPROVALS		
Product Mgr	Doc. Control	Design. Eng
Bruno Recaldini	Luo Luo	Sunny Chen
Date: 19-Mar-15	Date: 19-Mar-15	Date: 19-Mar-15

- Approval for Specification only
- Approval for Specification and Sample

TABLE OF CONTENTS

- 1 MAIN FEATURES.....4**
- 2 MECHANICAL SPECIFICATION5**
 - 2.1 MECHANICAL CHARACTERISTICS 5
 - 2.2 MECHANICAL DRAWING 6
- 3 ELECTRICAL SPECIFICATION7**
 - 3.1 ABSOLUTE MAXIMUM RATINGS 7
 - 3.2 ELECTRICAL CHARACTERISTICS 7
 - 3.3 INTERFACE PIN ASSIGNMENT..... 8
 - 3.4 TIMING CHARACTERISTICS 9
- 4 QUALITY ASSURANCE SPECIFICATION..... 10**
 - 4.1 CONFORMITY 10
 - 4.2 DELIVERY ASSURANCE..... 10
 - 4.3 DEALING WITH CUSTOMER COMPLAINTS..... 12
- 5 RELIABILITY SPECIFICATION..... 13**
 - 5.1 RELIABILITY TESTS 13
 - 5.2 DURABILITY 14
- 6 HANDLING PRECAUTIONS 15**

Product No.	DTC101-200-00	REV. 1.0
-------------	---------------	----------

Page	2 / 15
------	--------

REVISION RECORD

Rev.	Date	Page	Chapt.	Comment	ECR no.
1.0	20-Mar-15			First Release	

Product No.	DTC101-200-00	REV. 1.0
-------------	---------------	----------

Page	3 / 15
------	--------

1 MAIN FEATURES

ITEM	CONTENTS
Touch Type	Projected Capacitive
Simultaneous Touch Points	10
Screen Size	10.1"
Overall Dimensions (without FPC)	241.96(W) x 175.0(H) x 1.1(D) mm
Sensor Active Area	218.36 (W)x 137.0(H) mm
Structure	OGS (One-Layer Glass Solution)
Transparency	>88%
Haze	<2.0%
Hardness	>6H
Interface	I2C
IC controller	ILI2303
Operating temperature	-20 ~ 70°C
Storage temperature	-30 ~ 80°C

Product No.	DTC101-200-00	REV. 1.0
-------------	---------------	----------

Page	4 / 15
------	--------

2 MECHANICAL SPECIFICATION

2.1 MECHANICAL CHARACTERISTICS

ITEM	CHARACTERISTIC	UNIT
Screen Size	10.1"	
Overall Dimensions (without FPC)	241.96(W) x 175.0(H) x 1.1(D)	mm
Sensor Active Area	218.36 (W)x 137.0(H)	mm
Structure	OGS (One Layer Glass Solution)	

Product No.	DTC101-200-00	REV. 1.0
-------------	---------------	----------

Page	5 / 15
------	--------

2.2 MECHANICAL DRAWING

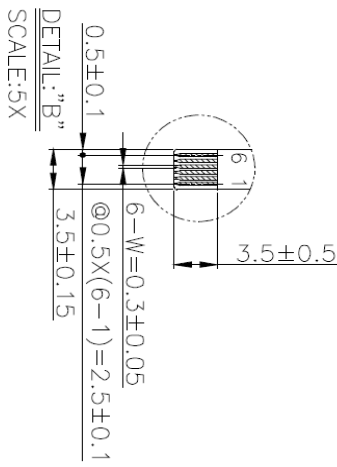
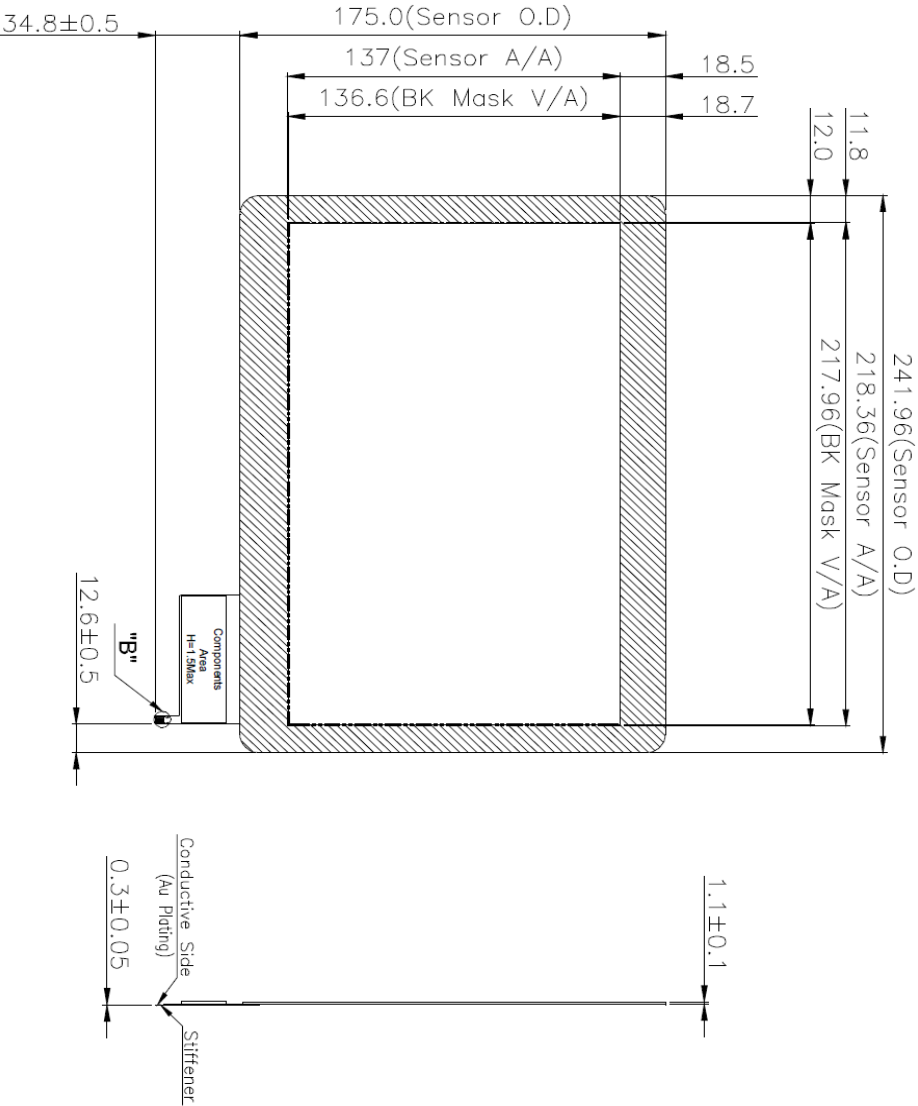

Product No.	DTC101-200-00	REV. 1.0
-------------	---------------	----------

Page	6 / 15
------	--------

3 ELECTRICAL SPECIFICATION

3.1 ABSOLUTE MAXIMUM RATINGS

VSS = 0 V, Ta = 25 °C

Item	Symbol	Min	Max	Unit	Note
Power Supply Voltage	V _{DD}	3.0	3.6	V	
Operating Temperature	Top	-20	70	°C	
Storage Temperature	Tst	-30	80	°C	
Static Electricity	Be sure that you are grounded when handling touch panels.				

3.2 ELECTRICAL CHARACTERISTICS

VSS = 0 V, Ta = 25 °C

Item	Symbol	Condition	Min	Typ	Max	Unit
Power Supply for Logic	V _{DD}	Ta = 25 °C	3.0	3.3	3.6	V
Current Consumption	I _{DD}		-	TBD	-	mA
Insulation Resistance	-	DC 25V	-	≥20		MΩ
Linearity	-	-	-	≤3		%
Chattering	-	-	-	≤15		ms

Product No.	DTC101-200-00	REV. 1.0
-------------	---------------	----------

Page	7 / 15
------	--------

3.3 INTERFACE PIN ASSIGNMENT

Recommended Connector: Elco 04 6240 006 026 846+ bottom contact or equivalent

No.	Symbol	I/O/P	Function
1	VDD	P	Power supply voltage for digital circuit
2	RST	I	Reset
3	INT	I	Interrupt
4	SCL	I	I2C Series Clock
5	SDA	I	I2C Series Data
6	GND	P	Power Voltage for digital circuit

Product No.	DTC101-200-00	REV. 1.0
-------------	---------------	----------

Page	8 / 15
------	--------

3.4 TIMING CHARACTERISTICS

I²C interface

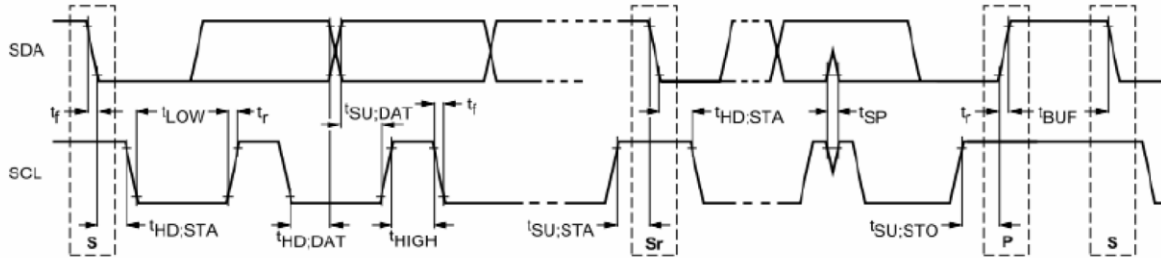

Symbol	Parameter	100KHz			400KHz		
		Min	Max	Unit	Min	Max	Unit
f_{SCL}	SCL clock frequency	0	100	kHz	0	400	kHz
$t_{HD,STA}$	Hold time (repeated) START condition. After this period, the first clock pulse is generated	4.0	–	μ s	0.6	–	μ s
t_{LOW}	LOW period of the SCL clock	4.7	–	μ s	1.3	–	μ s
t_{HIGH}	HIGH period of the SCL clock	4.0	–	μ s	0.6	–	μ s
$t_{SU,STA}$	Set-up time for a repeated START condition	4.7	–	μ s	0.6	–	μ s
$t_{HD,DAT}$	Data hold time	5.0	–	μ s	0	0.9	μ s
$t_{SU,DAT}$	Data set-up time	250	–	ns	100	–	ns
t_r	Rise time of both SDA and SCL signals	–	1000	ns	–	300	ns
t_f	Fall time of both SDA and SCL signals	–	300	ns	–	300	ns
$t_{SU,STO}$	Set-up time for STOP condition	4.0	–	μ s	0.6	–	μ s
t_{BUF}	Bus free time between a STOP and START condition	4.7	–	μ s	1.3	–	μ s

4 QUALITY ASSURANCE SPECIFICATION

4.1 CONFORMITY

The performance, function and reliability of the shipped products conform to the Product Specification.

4.2 DELIVERY ASSURANCE

4.2.1 Delivery inspection standards

- ISO 2859-1 General Inspection Level II, single sampling level

The quality assurance levels are shown below:

Class	AQL (%)
Major defect	0.65%
Minor defect	2.5%
TOTAL	2.5%

4.2.2 Zone definition

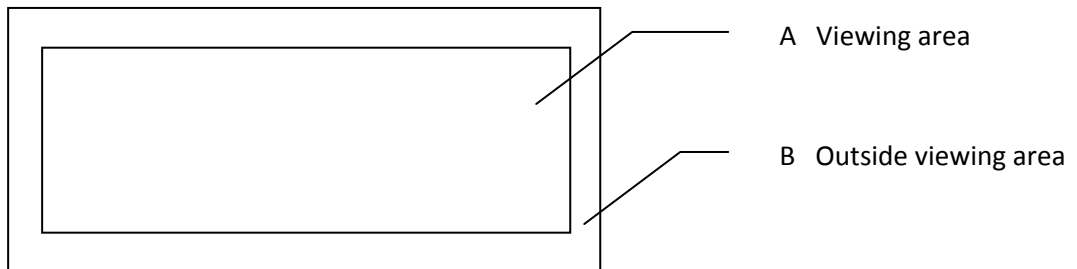

4.2.3 Visual inspection

- Inspect under 2x20W or 40W fluorescent lamp (approximately 3000 lux) leaving 30 ±5 cm between the product and the lamp and 30 cm between the product and the eye (measuring position).
- Inspect the product at 30° off vertical line.

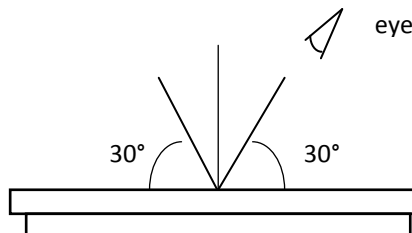

Product No.	DTC101-200-00	REV. 1.0
-------------	---------------	----------

Page	10 / 15
------	---------

4.2.3.1 Standard of appearance inspection

Units: mm

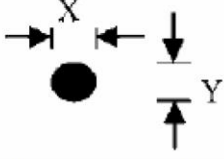
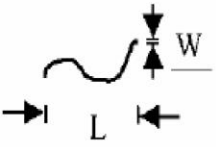
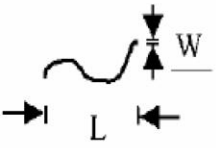
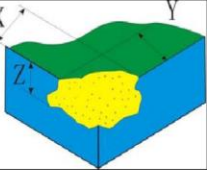
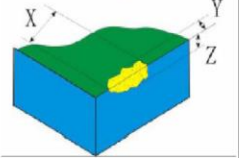
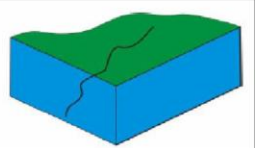
Item	Specification	Unit : mm	AQL															
Electrical Testing	1.1 Open 1.2 Short 1.3 T/P failure		0.65															
Circular Defects (Dirty / White point / Black point / Particle)	$D = (X+Y) / 2$  <table border="1" data-bbox="874 515 1260 728"> <thead> <tr> <th>Size(mm)</th> <th>Acceptable Q'ty</th> </tr> </thead> <tbody> <tr> <td>$D \leq 0.1$</td> <td>Ignored</td> </tr> <tr> <td>$0.1 < D \leq 0.2$</td> <td>Max 3 defect</td> </tr> <tr> <td>$0.2 < D \leq 0.3$</td> <td>Max 2 defect</td> </tr> <tr> <td>$D > 0.3$</td> <td>Reject</td> </tr> </tbody> </table> <p>*The particle will be ignored when it is removable by cleaning. * The distance between two defects should more than 10mm.</p>	Size(mm)	Acceptable Q'ty	$D \leq 0.1$	Ignored	$0.1 < D \leq 0.2$	Max 3 defect	$0.2 < D \leq 0.3$	Max 2 defect	$D > 0.3$	Reject		2.5					
Size(mm)	Acceptable Q'ty																	
$D \leq 0.1$	Ignored																	
$0.1 < D \leq 0.2$	Max 3 defect																	
$0.2 < D \leq 0.3$	Max 2 defect																	
$D > 0.3$	Reject																	
Linear Object (Dirty / White point / Black point / Particle)	 <table border="1" data-bbox="678 817 1332 1041"> <thead> <tr> <th>Length(mm)</th> <th>Width(mm)</th> <th>Acceptable Q'ty</th> </tr> </thead> <tbody> <tr> <td>-----</td> <td>$W \leq 0.02\text{mm}$</td> <td>Ignored</td> </tr> <tr> <td>$L \leq 3.0\text{mm}$</td> <td>$0.02\text{mm} < W \leq 0.05\text{mm}$</td> <td>Max 3 defect</td> </tr> <tr> <td>$L \leq 2.0\text{mm}$</td> <td>$0.05\text{mm} < W \leq 0.08\text{mm}$</td> <td>Max 2 defect</td> </tr> <tr> <td>-----</td> <td>$W > 0.08\text{mm}$</td> <td>Reject</td> </tr> </tbody> </table> <p>* The particle will be ignored when it is removable by cleaning. * The distance between two defects should more than 10mm.</p>	Length(mm)	Width(mm)	Acceptable Q'ty	-----	$W \leq 0.02\text{mm}$	Ignored	$L \leq 3.0\text{mm}$	$0.02\text{mm} < W \leq 0.05\text{mm}$	Max 3 defect	$L \leq 2.0\text{mm}$	$0.05\text{mm} < W \leq 0.08\text{mm}$	Max 2 defect	-----	$W > 0.08\text{mm}$	Reject		2.5
Length(mm)	Width(mm)	Acceptable Q'ty																
-----	$W \leq 0.02\text{mm}$	Ignored																
$L \leq 3.0\text{mm}$	$0.02\text{mm} < W \leq 0.05\text{mm}$	Max 3 defect																
$L \leq 2.0\text{mm}$	$0.05\text{mm} < W \leq 0.08\text{mm}$	Max 2 defect																
-----	$W > 0.08\text{mm}$	Reject																
Scratch	 <table border="1" data-bbox="678 1131 1332 1355"> <thead> <tr> <th>Length(mm)</th> <th>Width(mm)</th> <th>Acceptable Q'ty</th> </tr> </thead> <tbody> <tr> <td>-----</td> <td>$W \leq 0.02\text{mm}$</td> <td>Ignored</td> </tr> <tr> <td>$L \leq 3.0\text{mm}$</td> <td>$0.02\text{mm} < W \leq 0.05\text{mm}$</td> <td>Max 3 defect</td> </tr> <tr> <td>$L \leq 2.0\text{mm}$</td> <td>$0.05\text{mm} < W \leq 0.08\text{mm}$</td> <td>Max 2 defect</td> </tr> <tr> <td>-----</td> <td>$W > 0.08\text{mm}$</td> <td>Reject</td> </tr> </tbody> </table> <p>* The distance between two defects should more than 10mm.</p>	Length(mm)	Width(mm)	Acceptable Q'ty	-----	$W \leq 0.02\text{mm}$	Ignored	$L \leq 3.0\text{mm}$	$0.02\text{mm} < W \leq 0.05\text{mm}$	Max 3 defect	$L \leq 2.0\text{mm}$	$0.05\text{mm} < W \leq 0.08\text{mm}$	Max 2 defect	-----	$W > 0.08\text{mm}$	Reject		2.5
Length(mm)	Width(mm)	Acceptable Q'ty																
-----	$W \leq 0.02\text{mm}$	Ignored																
$L \leq 3.0\text{mm}$	$0.02\text{mm} < W \leq 0.05\text{mm}$	Max 3 defect																
$L \leq 2.0\text{mm}$	$0.05\text{mm} < W \leq 0.08\text{mm}$	Max 2 defect																
-----	$W > 0.08\text{mm}$	Reject																
Chip And Crack	Corner chip: $X < 2\text{mm}$ and $Y < 2\text{mm}$ and $Z < 1/2\text{GT}$ ignored 1 Corner chip in the golden finger that seriously affects the product function.		2.5															
	Side chip: $X < 2\text{mm}$ and $Y < 2\text{mm}$ and $Z < 1/2\text{GT}$ ignored 1 Side chip in the golden finger that seriously affects the product function.		2.5															
	No Crack is allowed.		2.5															

4.3 DEALING WITH CUSTOMER COMPLAINTS

4.3.1 Non-conforming analysis

Purchaser should supply Densitron with detailed data of non-conforming sample.
After accepting it, Densitron should complete the analysis in two weeks from receiving the sample.
If the analysis cannot be completed on time, Densitron must inform the purchaser.

4.3.2 Handling of non-conforming products

If any non-conforming products are found during customer acceptance inspection which Densitron is clearly responsible for, return them to Densitron.
Both Densitron and customer should analyse the reason and discuss the handling of non-conforming products when the reason is not clear.
Equally, both sides should discuss and come to agreement for issues pertaining to modification of Densitron quality assurance standard.

Product No.	DTC101-200-00	REV. 1.0
-------------	---------------	----------

Page	12 / 15
------	---------

5 RELIABILITY SPECIFICATION

5.1 RELIABILITY TESTS

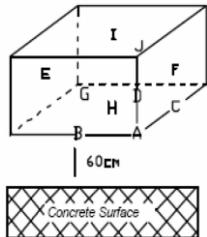
Test Item	Test Condition	Evaluation and assessment
High Temperature Storage	80°C, 120 hr	No abnormalities in function* and appearance
Low Temperature Storage	-30°C, 120 hr	No abnormalities in function* and appearance
High Temperature Operating	70°C, 120 hr	No abnormalities in function* and appearance
Low Temperature Operating	-20°C, 120 hr	No abnormalities in function* and appearance
High Temperature & High Humidity Storage	60°C, 90%RH, 120 hr	No abnormalities in function* and appearance
Thermal Shock Storage	-30°C → 20 °C → 80°C → 20 °C (30min → 5min → 30min → 5min), 10 cycles	No abnormalities in function* and appearance
Packaging vibration	Frequency range: 10Hz ~ 55Hz Vibration Amplitude: 1.5mm Sweeping time: 12 min 2 hours in each X, Y, Z direction	No abnormalities in function* and appearance
Packaging drop test	<p>To be measured after dropping the package from 60cm height on concrete surface</p>  <p>Corner dropping: - A corner: once Edge dropping: - B, C, D edge: once Face dropping: - E, F, G, H, I, J face: once</p>	

Samples must be stored at room temperature for 24 hours after the tests, before final inspection is carried out.

* Current consumption < 2 times initial value

Product No.	DTC101-200-00	REV. 1.0
-------------	---------------	----------

Page	13 / 15
------	---------

5.2 DURABILITY

Items	Conditions	Spec.
Ball Drop test	1. steel ball weight: 64g / Ø25.4mm 2. drop from 40cm height 3. impact area: AA center(no second impact)	1. Before and after test, Product function is OK. 2. Before and after test, Product can't breaking.
TP point hitting life	>1,000,000	Before and after test, Product function is OK.
Pen sliding durability	>100,000	Before and after test, Product function is OK.

Note. All the tests and determines are under the office Temperature and Humidity ambient.

Product No.	DTC101-200-00	REV. 1.0
-------------	---------------	----------

Page	14 / 15
------	---------

6 HANDLING PRECAUTIONS

Storage

Store the products at the temperature and humidity range presented in the specification.

Store the products in the state of package.

Do not expose the product to a direct ray of the sun.

Unpacking

Do not hold FPC/Copper tail to take out touch panels in the package.

Use gloves and finger coat to prevent stains on the touch panel and injury by the sharp edge of the touch panel.

Do not take hold of FPC /Copper tail when handing the touch panel.

Do not pile up touch panels.

Handling

Do not put anything on the touch panel.

Do not fold the FPC /Copper tail.

Clean off the touch panel with alcohol and soft clothes when necessary

Prevent alcohol from penetrating into the touch panel.

Do not use organic solvents except for alcohol.

Assembly

Avoid excessive force on the touch panel.

Do not give unnecessary strain to the FPC /Copper tail while assembling.

Operation

Do not operate touch panel by applying excessive force.

Do not use a sharp thing for input.

We recommend calibration after long time use.

Product No.	DTC101-200-00	REV. 1.0
-------------	---------------	----------

Page	15 / 15
------	---------