

**TITLE : DV240FBM-NB0****Product Specification****Rev. 0**

SPLCD.com  
Supply & Purchase Cloud Platform

**BEIJING BOE OPTOELECTRONICS TECHNOLOGY**SPEC. NUMBER  
S8-64-5A-058PRODUCT GROUP  
TFT-LCD

Rev.0

ISSUE DATE  
2016.10.11PAGE  
1 OF 30



## Contents

No.	Item	Page
1.0	General Description	4
2.0	Absolute Maximum Ratings	6
3.0	Electrical Specifications	7
4.0	Optical Specifications	9
5.0	Interface Connection	12
6.0	Signal Timing Specifications	15
7.0	Signal Timing Waveforms of Interface Signal	17
8.0	Input Signals, Display Colors & Gray Scale of Colors	19
9.0	Power Sequence	20
10.0	Mechanical Characteristics	21
11.0	Reliability Test	22
12.0	Handling & Cautions	23
13.0	Product Serial Number	24
14.0	Packing	25
15.0	Appendix	27

## 1.0 GENERAL DESCRIPTION

### 1.1 Introduction

24" FHD(1920\*360) is a color active matrix TFT LCD module using amorphous silicon TFT's (Thin Film Transistors) as an active switching devices. This module has a 24 inch diagonally measured active area with WXGA resolutions (1920horizontal by 360 vertical pixel array). Each pixel is divided into RED, GREEN, BLUE dots which are arranged in vertical stripe and this module can display 16.7M colors. The TFT-LCD panel used for this module is adapted for a low reflection and higher color type.

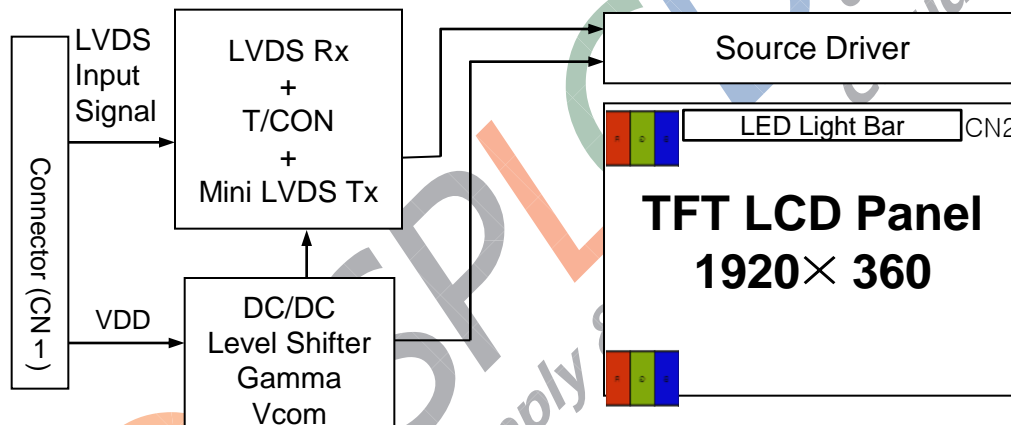

### 1.2 Features

- LVDS Interface with 2 pixel / clock
- Low power consumption
- 6-bit (Hi-FRC) color depth, display 16.7M colors
- Incorporated edge type back-light (One Light Bar)
- High luminance and contrast ratio, low reflection and normal viewing angle
- DE (Data Enable) only
- RoHS
- ES 6.0 compliant
- Gamma correction

### 1.3 Application

- Desktop Type of PC & Workstation Use
- Slim-Size Display for Stand-alone Monitor
- Display Terminals for Control System
- Monitors for Process Controller

### 1.4 General Specification

The followings are general specifications at the model.

<Table 1. General Specifications>

Parameter	Specification	Unit	Remarks
Active area	597.888(H) × 112.104(V)	mm	
Number of pixels	1920(H) × 360(V)	pixels	
Pixel pitch	0.3114(H) × 0.3114(V)	mm	
Pixel arrangement	RGB Vertical stripe		
Display colors	16.7M	colors	
Display mode	Normally Black		
Dimensional outline	612.7(H) × 132.1(V) × 8.4(B)	mm	Detail refer to drawing
Weight	1210(typ.)	g	
Bezel width (L/R/U/D)	6/6/11/6	mm	
Surface Treatment	Haze 25%		
Back-light	Up edge side, 1- LED Light bar		

## 2.0 ABSOLUTE MAXIMUM RATINGS

The followings are maximum values which, if exceed, may cause faulty operation or damage to the unit. The operational and non-operational maximum voltage and current values are listed in Table 2.

< Table 2. Absolute Maximum Ratings >

[VSS=GND=0V]

Parameter	Symbol	Min.	Max.	Unit	Remarks
Power Supply Voltage	$V_{DD}$	-0.3	7	V	Ta = 25 °C
Logic Supply Voltage	$V_{IN}$	VSS-0.3	$V_{DD}+0.3$	V	
LED Channel Current	$I_{BL}$	-	85	mA	
Operating Temperature	$T_{OP}$	0	+50	°C	1)
Storage Temperature	$T_{ST}$	-20	+60	°C	1)

Note : 1) Temperature and relative humidity range are shown in the figure below.  
Wet bulb temperature should be 39 °C max. and no condensation of water.

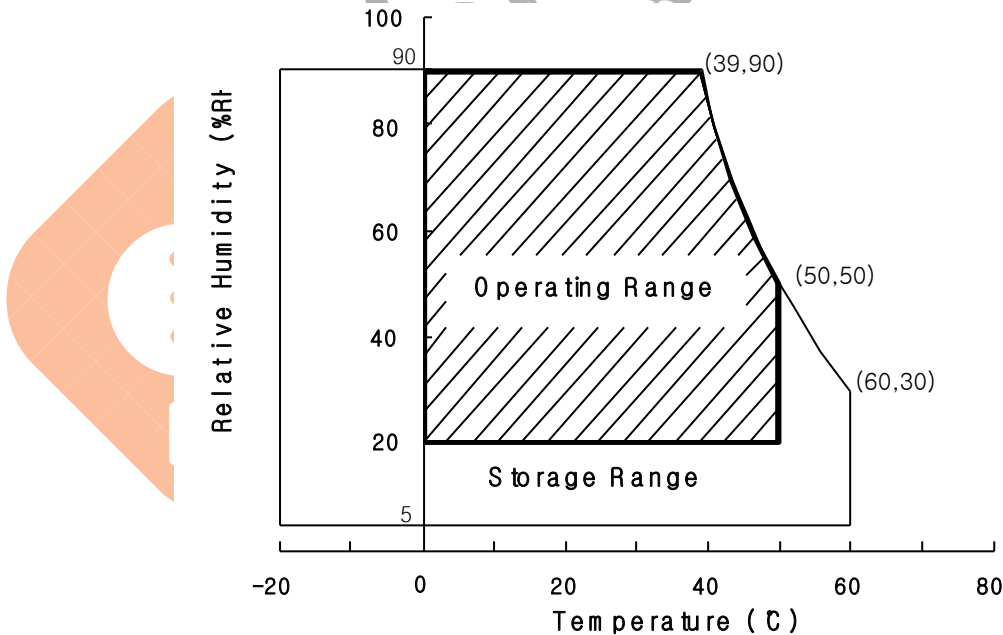

## 3.0 ELECTRICAL SPECIFICATIONS

### 3.1 Electrical Specifications

< Table 3. Electrical specifications >

[Ta =25 ± 2 °C]

Parameter		Min.	Typ.	Max.	Unit	Remarks
Power Supply Voltage	V <sub>DD</sub>	4.5	5.0	5.5	V	Note1
Power Supply Current	I <sub>DD</sub>	-	600	800	mA	
In-Rush Current	I <sub>RUSH</sub>	-	2	3	A	Note 2
Permissible Input Ripple Voltage	V <sub>RF</sub>	-	-	300	mV	Note1,3
High Level Differential Input Threshold Voltage	V <sub>IH</sub>	-	-	+100	mV	
Low Level Differential Input Threshold Voltage	V <sub>IL</sub>	-100	-	-	mV	
Differential input voltage	V <sub>ID</sub>	200	-	600	mV	
Differential input common mode voltage	V <sub>cm</sub>	1.0	1.2	1.5		V <sub>IH</sub> =100mV, V <sub>IL</sub> =-100mV
LED Channel Voltage	V <sub>L</sub>	50.4	54	55.8	V	
LED Channel Current	I <sub>L</sub>	-	30	40	mA	
LED Lifetime		30,000	-	-	Hrs	
Power Consumption	P <sub>D</sub>	-	3.0	4.0	W	@60Hz
	P <sub>BL</sub>	-	8.1	11.2	W	
	P <sub>total</sub>	-	11.1	15.2	W	

Notes : 1. The supply voltage is measured and specified at the interface connector of LCM.

The current draw and power consumption specified is for VDD=5.0V, Frame rate=60Hz and Clock frequency = 75.4MHz. Test Pattern of power supply current

a) Typ: Color Test

b) Max: Skip Sub Pixel

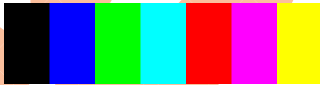

a)



b)

2. Duration of rush current is about 2 ms and rising time of VDD is 520 μs ± 20 %

3. Ripple Voltage should be covered by Input voltage Spec.

4. Calculated value for reference (V<sub>L</sub> × I<sub>L</sub>) × 5(channel) excluding driver loss. (LED Light bar: 18S5P)

### 3.2 Backlight Unit

< Table 4. LED Backlight Unit >

Parameter		Min.	Typ.	Max.	Unit	Remarks
LED Light Bar Input Voltage Per Input Pin	VPIN	50.4	54	55.8	V	Duty 100%
LED Light Bar Input Current Per Input Pin	IPIN	-	30	40	mA	Note1,2,
LED Power Consumption	P <sub>BL</sub>	-	8.1	11.2	W	Note 3
LED Life-Time	-	30,000	-	-	Hrs	Note 4

LED bar consists of 90LED packages,5strings(parallel)\*18packages(serial)

Note1: There are one light bar ,and the specified current is input LED chip 100% duty current

Note2: The sense current of each input pin is 30mA

Note3: PBL=5 Input pins\*VPIN × IPIN

Note4: The lifetime is determined as the time at which luminance of LED become 50% of the initial brightness or not normal lighting at IPIN=30mA on condition of continuous operating at 25 ± 2 °C



## 4.0 OPTICAL SPECIFICATION

### 4.1 Overview

The test of Optical specifications shall be measured in a dark room (ambient luminance  $\leq 1$  lux and temperature =  $25 \pm 2^\circ\text{C}$ ) with the equipment of Luminance meter system (Goniometer system and TOPCONE PR730) and test unit shall be located at an approximate distance 50cm from the LCD surface at a viewing angle of  $\theta$  and  $\Phi$  equal to  $0^\circ$ . We refer to  $\theta_{\phi=0}$  ( $=\theta_3$ ) as the 3 o'clock direction (the "right"),  $\theta_{\phi=90}$  ( $=\theta_{12}$ ) as the 12 o'clock direction ("upward"),  $\theta_{\phi=180}$  ( $=\theta_9$ ) as the 9 o'clock direction ("left") and  $\theta_{\phi=270}$  ( $=\theta_6$ ) as the 6 o'clock direction ("bottom"). While scanning  $\theta$  and/or  $\phi$ , the center of the measuring spot on the Display surface shall stay fixed. The measurement shall be executed after 30 minutes warm-up period. VDD shall be 5.0V  $\pm$ 10% at  $25^\circ\text{C}$ . Optimum viewing angle direction is 6 o'clock.

### 4.2 Optical Specifications

[VDD = 5.0V, Frame rate = 60Hz, Clock = 75.4MHz,  $I_{BL} = 150$  mA,  $T_a = 25 \pm 2^\circ\text{C}$ ]

< Table 5. Module Optical >

Parameter		Symbol	Condition	Min.	Typ.	Max.	Unit	Remark				
Viewing Angle range	Horizontal	$\Theta_3$	CR > 10	85	89	-	Deg.	Note 1				
		$\Theta_9$		85	89	-	Deg.					
	Vertical	$\Theta_{12}$		85	89	-	Deg.					
		$\Theta_6$		85	89	-	Deg.					
Luminance Contrast ratio		CR		900	1200	-		Note 2				
Luminance of White		$Y_w$		250	300	-	cd/m <sup>2</sup>	Note 3				
White luminance uniformity		$\Delta Y$		75	80	-	%	Note 4				
Reproduction of color	White	$W_x$	$\Theta = 0^\circ$ (Center) Normal Viewing Angle	0.282	0.312	0.342	-	Note 5				
		$W_y$		0.297	0.327	0.357						
	Red	$R_x$		0.626	0.656	0.686						
		$R_y$		0.299	0.329	0.359						
	Green	$G_x$		0.273	0.303	0.333						
		$G_y$		0.580	0.610	0.640						
	Blue	$B_x$		0.109	0.139	0.169						
		$B_y$		0.059	0.089	0.119						
	Color Gamut					-			72	-	%	
	Response Time	TR		Tr+Tf		-			30	35	ms	Note 6

**Note :**

1. Viewing angle is the angle at which the contrast ratio is greater than 10. The viewing are determined for the horizontal or 3, 9 o'clock direction and the vertical or 6, 12 o'clock direction with respect to the optical axis which is normal to the LCD surface.
2. Contrast measurements shall be made at viewing angle of  $\theta = 0^\circ$  and at the center of the LCD surface. Luminance shall be measured with all pixels in the view field set first to white, then to the dark (black) state. (See FIGURE 1 shown in Appendix) Luminance Contrast Ratio (CR) is defined mathematically.

$$CR = \frac{\text{Luminance when displaying a white raster}}{\text{Luminance when displaying a black raster}}$$

3. Center Luminance of white is defined as the LCD surface. Luminance shall be measured with all pixels in the view field set first to white. This measurement shall be taken at the locations shown in FIGURE 2 for a total of the measurements per display.
4. The White luminance uniformity on LCD surface is then expressed as :  
 $\Delta Y = ( \text{Minimum Luminance of 9points} / \text{Maximum Luminance of 9points} ) * 100$   
 (See FIGURE 2 shown in Appendix).
5. The color chromaticity coordinates specified in Table 5. shall be calculated from the spectral data measured with all pixels first in red, green, blue and white. Measurements shall be made at the center of the panel. 基于B1开发CA2000测试结果.
6. The electro-optical response time measurements shall be made by switching the "data" input signal ON and OFF. The times needed for the luminance to change from 10% to 90% is  $T_r$ , and 90% to 10% is  $T_f$ .

## 5.0 INTERFACE CONNECTION.

### 5.1 Electrical Interface Connection

#### 5.1.1 LED Light Bar

-LED connector : [CI1407M1VL0-NH](#) manufactured by Entry

< Table 6. LED Light Bar >

Pin No	Symbol	Description
1	IRLED1	LED current sense for string1
2	IRLED2	LED current sense for string2
3	VLED	LED power supply
4	VLED	LED power supply
5	IRLED3	LED current sense for string3
6	IRLED4	LED current sense for string4
7	IRLED5	LED current sense for string5



## 5.0 INTERFACE CONNECTION.

### 5.1 Electrical Interface Connection

- CN1      Module Side Connector : UJU IS100-300-C23 or Equivalent  
User Side Connector : JAE FI-X30H or Equivalent

Pin No	Symbol	Function	Remark
1	RX00-	Negative Transmission data of Pixel 0 (ODD)	
2	RX00+	Positive Transmission data of Pixel 0 (ODD)	
3	RX01-	Negative Transmission data of Pixel 1 (ODD)	
4	RX01+	Positive Transmission data of Pixel 1 (ODD)	
5	RX02-	Negative Transmission data of Pixel 2 (ODD)	
6	RX02+	Positive Transmission data of Pixel 2 (ODD)	
7	GND	Power Ground	
8	RXOC-	Negative Transmission Clock (ODD)	
9	RXOC+	Positive Transmission Clock (ODD)	
10	RX03-	Negative Transmission data of Pixel 3 (ODD)	
11	RX03+	Positive Transmission data of Pixel 3 (ODD)	
12	RXE0-	Negative Transmission data of Pixel 0 (EVEN)	
13	RXE0+	Positive Transmission data of Pixel 0 (EVEN)	
14	GND	Power Ground	
15	RXE1-	Negative Transmission data of Pixel 1 (EVEN)	
16	RXE1+	Positive Transmission data of Pixel 1 (EVEN)	
17	GND	Power Ground	
18	RXE2-	Negative Transmission data of Pixel 2 (EVEN)	
19	RXE2+	Positive Transmission data of Pixel 2 (EVEN)	
20	RXEC-	Negative Transmission Clock (EVEN)	
21	RXEC+	Positive Transmission Clock (EVEN)	
22	RXE3-	Negative Transmission data of Pixel 3 (EVEN)	
23	RXE3+	Positive Transmission data of Pixel 3 (EVEN)	
24	GND	Power Ground	
25	CTL	CTL_DVR for LCD manufacturer	
26	CE	CE_DVR for LCD manufacturer	
27	NC	Not connection	
28	VDD1	Power Supply:+5V	
29	VDD2		
30	VDD3		

### 5.2 LVDS Interface ( Tx; THC63LVDF83A or Equivalent )

#### 5.2.1 LVDS Interface

	Input Signal	Transmitter		Interface		(CN11)	Remark
		Pin No.	Pin No.	System (Tx)	TFT-LCD (Rx)	Pin No.	
O D D  L V D S	OR0	51	48 47	OUT0- OUT0+	RX00- RX00+	1 2	
	OR1	52					
	OR2	54					
	OR3	55					
	OR4	56					
	OR5	3					
	OG0	4	46 45	OUT1- OUT1+	RX01- RX01+	3 4	
	OG1	6					
	OG2	7					
	OG3	11					
	OG4	12					
	OG5	14					
	OB0	15	42 41	OUT2- OUT2+	RX02- RX02+	5 6	
	OB1	19					
	OB2	20					
	OB3	22					
	OB4	23					
	OB5	24					
	Hsync	27	40 39	CLK OUT- CLK OUT+	RXO CLK- RXO CLK+	8 9	
	Vsync	28					
	DE	30					
	MCLK	31					
	OR6	50					
	OR7	2					
	OG6	8	38 37	OUT3- OUT3+	RX03- RX03+	10 11	
OG7	10						
OB6	16						
OB7	18						
RSVD	25						

## 5.2 LVDS Interface ( Tx; THC63LVDF83A or Equivalent )

### 5.2.1 LVDS Interface

	Input Signal	Transmitter		Interface		(CN11)	Remark
		Pin No.	Pin No.	System (Tx)	TFT-LCD (Rx)	Pin No.	
E V E N  L V D S	ER0	51	48 47	OUT0- OUT0+	RXE0- RXE0+	12 13	
	ER1	52					
	ER2	54					
	ER3	55					
	ER4	56					
	ER5	3					
	EG0	4	46 45	OUT1- OUT1+	RXE1- RXE1+	15 16	
	EG1	6					
	EG2	7					
	EG3	11					
	EG4	12					
	EG5	14					
	EB0	15	42 41	OUT2- OUT2+	RXE2- RXE2+	18 19	
	EB1	19					
	EB2	20					
	EB3	22					
	EB4	23					
	EB5	24					
	Hsync	27	40 39	CLK OUT- CLK OUT+	RXE CLK- RXE CLK+	20 21	
	Vsync	28					
	DE	30					
	MCLK	31	38 37	OUT3- OUT3+	RXE3- RXE3+	22 23	
	ER6	50					
	ER7	2					
	EG6	8					
EG7	10						
EB6	16						
EB7	18						
RSVD	25						

## 6.0 SIGNAL TIMING SPECIFICATION

6.1 24inch FHD MDL is operated by the DE only.

Item		Symbols	Min	Typ	Max	Unit
Clock	Frequency	1/Tc	61.93	74.32	92.90	MHz
	High Time	Tch	-	4/7 Tc	-	
	Low Time	Tcl	-	3/7 Tc	-	
Frame Period		Tv	1091	1125	1149	lines
			50	60	75	Hz
			20	16.67	13.33	ms
Vertical Display Period		Tvd	-	1080	-	lines
One line Scanning Period		Th	1060	1100	1200	clocks
Horizontal Display Period		Thd	-	960	-	clocks
Modulating frequency of input clock during SSC		FLV <sub>MOD</sub> ( F=85MH z, V <sub>IC</sub> =1. 2V, V <sub>ID</sub> = ±200m V)	10	-	300	KHz
Maximum deviation of input clock during SSC		FLV <sub>DEV</sub> (F =85MHz , V <sub>IC</sub> =1.2 V, V <sub>ID</sub> =± 200mV)	-3	-	+3	%

### 6.2 LVDS Rx Interface Timing Parameter

The specification of the LVDS Rx interface timing parameter is shown in Table 7.

<Table 7. LVDS Rx Interface Timing Specification>

Item	Symbol	Min	Typ	Max	Unit	Remark
CLKIN Period	tRCIP	10.60	13.25	20.00	nsec	
Input Data 0	tRIP1	-0.4	0.0	+0.4	nsec	
Input Data 1	tRIP0	tRCIP/7-0.4	tRCIP/7	tRCIP/7+0.4	nsec	
Input Data 2	tRIP6	2 × tRCIP/7-0.4	2 × tRCIP/7	2 × tRCIP/7+0.4	nsec	
Input Data 3	tRIP5	3 × tRCIP/7-0.4	3 × tRCIP/7	3 × tRCIP/7+0.4	nsec	
Input Data 4	tRIP4	4 × tRCIP/7-0.4	4 × tRCIP/7	4 × tRCIP/7+0.4	nsec	
Input Data 5	tRIP3	5 × tRCIP/7-0.4	5 × tRCIP/7	5 × tRCIP/7+0.4	nsec	
Input Data 6	tRIP2	6 × tRCIP/7-0.4	6 × tRCIP/7	6 × tRCIP/7+0.4	nsec	

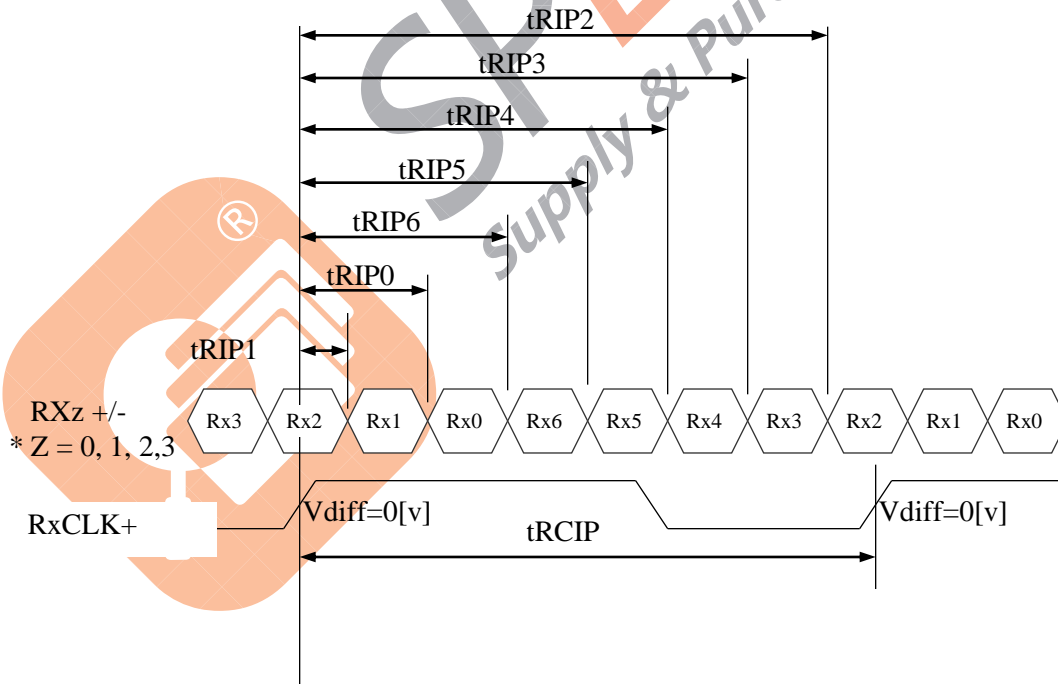

\* Vdiff = (RXz+)-(RXz-),.... ,(RXCLK+)-(RXCLK-)



## 7.0 SIGNAL TIMING WAVEFORMS OF INTERFACE SIGNAL

### 7.1 Sync Timing Waveforms

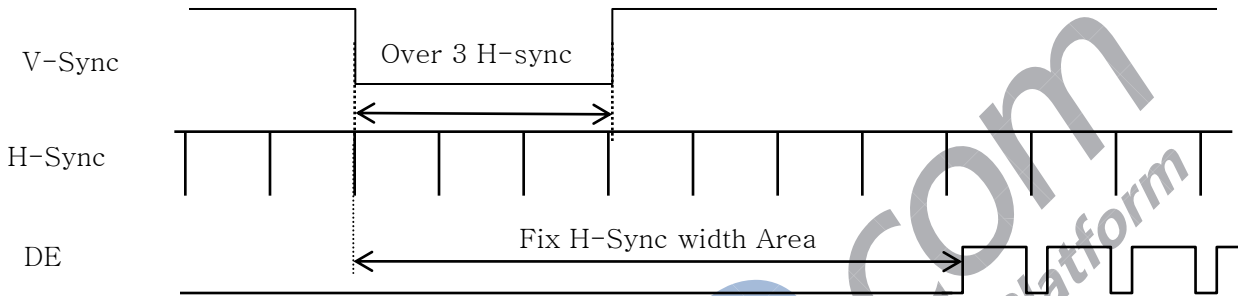

- 1) Need over 3 H-sync during V-Sync Low
- 2) Fix H-Sync width from V-Sync falling edge to first rising edge

### 7.2 Vertical Timing Waveforms

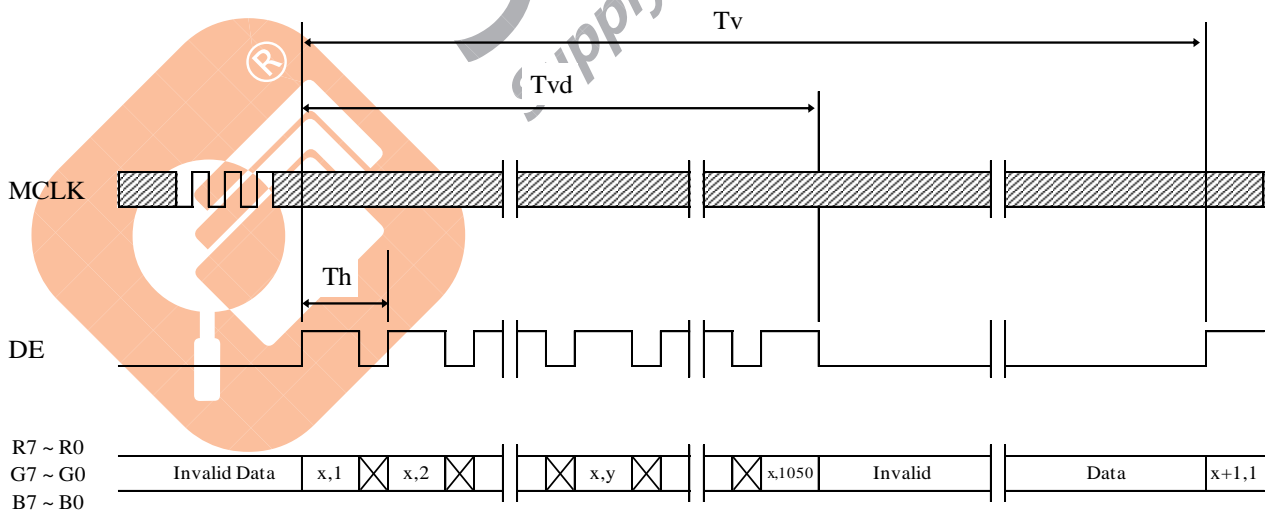

### 7.3 Horizontal Timing Waveforms

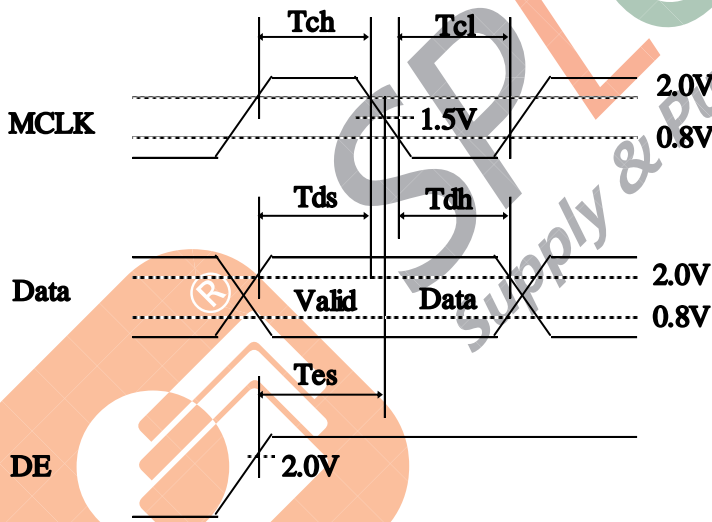
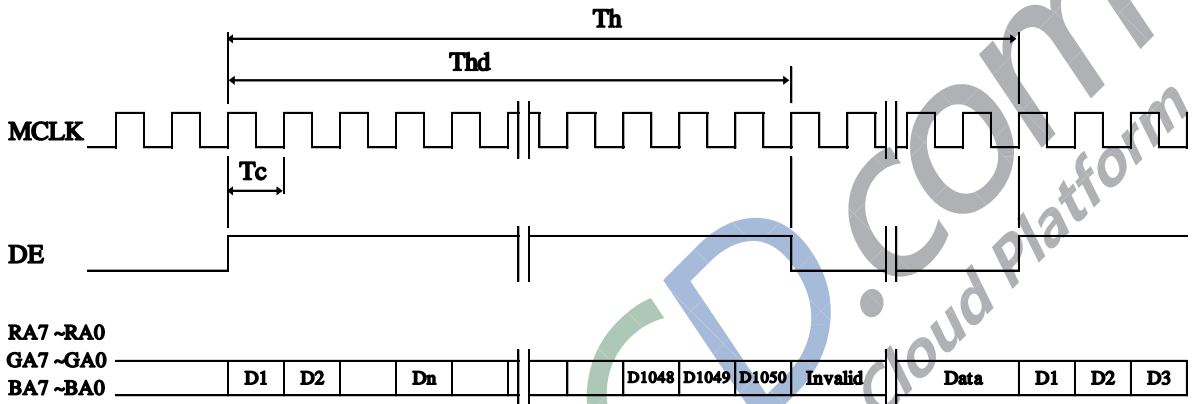

## 8.0 INPUT SIGNALS, BASIC DISPLAY COLORS & GRAY SCALE OF COLORS

Color & Gray Scale		RED DATA								GREEN DATA								BLUE DATA							
		R7	R6	R5	R4	R3	R2	R1	R0	G7	G6	G5	G4	G3	G2	G1	G0	B7	B6	B5	B4	B3	B2	B1	B0
Basic Colors	Black	0	0	0	0	0	0	0	0	0	0	0	0	0	0	0	0	0	0	0	0	0	0	0	0
	Blue	0	0	0	0	0	0	0	0	0	0	0	0	0	0	0	0	1	1	1	1	1	1	1	1
	Green	0	0	0	0	0	0	0	0	1	1	1	1	1	1	1	1	0	0	0	0	0	0	0	0
	Cyan	0	0	0	0	0	0	0	0	1	1	1	1	1	1	1	1	1	1	1	1	1	1	1	1
	Red	1	1	1	1	1	1	1	1	0	0	0	0	0	0	0	0	0	0	0	0	0	0	0	0
	Magenta	1	1	1	1	1	1	1	1	0	0	0	0	0	0	0	0	1	1	1	1	1	1	1	1
	Yellow	1	1	1	1	1	1	1	1	1	1	1	1	1	1	1	1	0	0	0	0	0	0	0	0
	White	1	1	1	1	1	1	1	1	1	1	1	1	1	1	1	1	1	1	1	1	1	1	1	1
Gray Scale of RED	Black	0	0	0	0	0	0	0	0	0	0	0	0	0	0	0	0	0	0	0	0	0	0	0	0
	△	0	0	0	0	0	0	1	0	0	0	0	0	0	0	0	0	0	0	0	0	0	0	0	0
	Darker	0	0	0	0	0	0	1	0	0	0	0	0	0	0	0	0	0	0	0	0	0	0	0	0
	△	↑								↑															
	▽	↓								↓															
	Brighter	1	1	1	1	1	1	0	1	0	0	0	0	0	0	0	0	0	0	0	0	0	0	0	0
	▽	1	1	1	1	1	1	0	0	0	0	0	0	0	0	0	0	0	0	0	0	0	0	0	0
	Red	1	1	1	1	1	1	1	1	0	0	0	0	0	0	0	0	0	0	0	0	0	0	0	0
Gray Scale of GREEN	Black	0	0	0	0	0	0	0	0	0	0	0	0	0	0	0	0	0	0	0	0	0	0	0	0
	△	0	0	0	0	0	0	0	0	0	0	0	0	0	0	0	1	0	0	0	0	0	0	0	0
	Darker	0	0	0	0	0	0	0	0	0	0	0	0	0	0	1	0	0	0	0	0	0	0	0	0
	△	↑								↑															
	▽	↓								↓															
	Brighter	0	0	0	0	0	0	0	0	1	1	1	1	1	1	0	1	0	0	0	0	0	0	0	0
	▽	0	0	0	0	0	0	0	0	1	1	1	1	1	1	1	0	0	0	0	0	0	0	0	0
	Green	0	0	0	0	0	0	0	0	1	1	1	1	1	1	1	1	0	0	0	0	0	0	0	0
Gray Scale of BLUE	Black	0	0	0	0	0	0	0	0	0	0	0	0	0	0	0	0	0	0	0	0	0	0	0	0
	△	0	0	0	0	0	0	0	0	0	0	0	0	0	0	0	0	0	0	0	0	0	0	0	1
	Darker	0	0	0	0	0	0	0	0	0	0	0	0	0	0	0	0	0	0	0	0	0	0	1	0
	△	↑								↑															
	▽	↓								↓															
	Brighter	0	0	0	0	0	0	0	0	0	0	0	0	0	0	0	0	1	1	1	1	1	1	0	1
	▽	0	0	0	0	0	0	0	0	0	0	0	0	0	0	0	0	1	1	1	1	1	1	1	0
	Blue	0	0	0	0	0	0	0	0	0	0	0	0	0	0	0	0	1	1	1	1	1	1	1	1
Gray Scale of WHITE	Black	0	0	0	0	0	0	0	0	0	0	0	0	0	0	0	0	0	0	0	0	0	0	0	0
	△	0	0	0	0	0	0	1	0	0	0	0	0	0	0	0	1	0	0	0	0	0	0	0	1
	Darker	0	0	0	0	0	0	1	0	0	0	0	0	0	0	1	0	0	0	0	0	0	0	1	0
	△	↑								↑															
	▽	↓								↓															
	Brighter	1	1	1	1	1	1	0	1	1	1	1	1	1	1	0	1	1	1	1	1	1	1	0	1
	▽	1	1	1	1	1	1	0	1	1	1	1	1	1	1	1	0	1	1	1	1	1	1	1	0
	White	1	1	1	1	1	1	1	1	1	1	1	1	1	1	1	1	1	1	1	1	1	1	1	1

## 9.0 POWER SEQUENCE

To prevent a latch-up or DC operation of the LCD module, the power on/off sequence shall be as shown in below

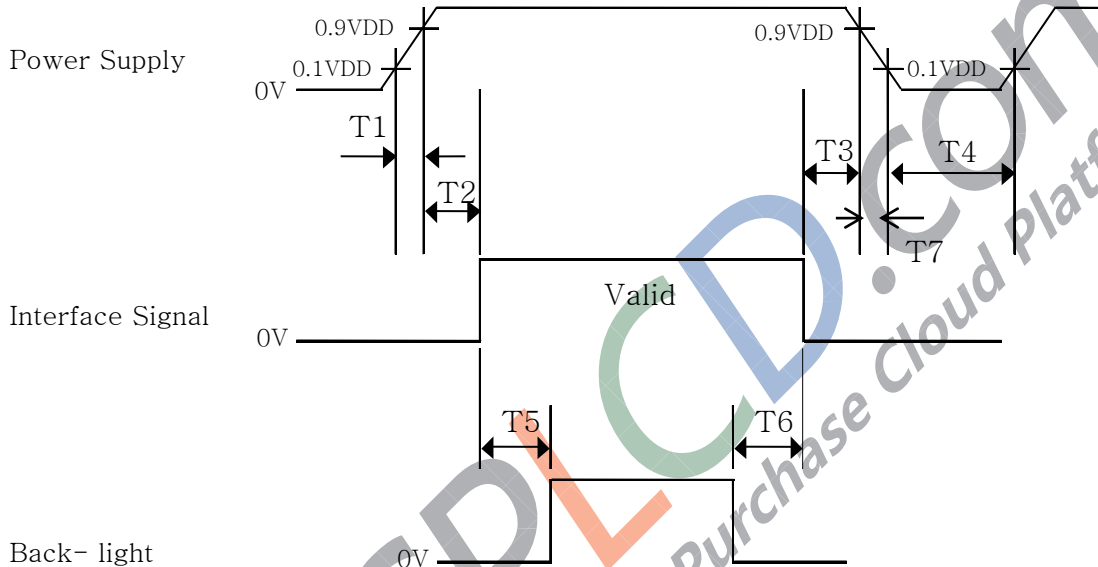

- $0.5 \text{ ms} \leq T1 \leq 10 \text{ ms}$
- $0 \leq T2 \leq 50 \text{ ms}$
- $0 \leq T3 \leq 50 \text{ ms}$
- $1 \text{ sec} \leq T4$
- $200 \text{ ms} \leq T5$
- $200 \text{ ms} \leq T6$

### Notes:

1. When the power supply VDD is 0V, keep the level of input signals on the low or keep high impedance.
2. Do not keep the interface signal high impedance when power is on.
3. Back Light must be turn on after power for logic and interface signal are valid.
4. T7 decreases smoothly, there is none re-bouncing voltage.

## 10.0 MECHANICAL CHARACTERISTICS

### 10.1 Dimensional Requirements

FIGURE 6 (located in Appendix) shows mechanical outlines for the model MV185WHM-N10. Other parameters are shown in Table 8.

<Table 8. Dimensional Parameters>

Parameter	Specification	Unit
Dimensional outline	612.7(H) × 132.1(V) × 8.4(B)	mm
Weight	1210(typ.)	gram
Active area	597.888(H) × 112.104(V)	mm
Pixel pitch	0.3114(H) × 0.3114(V)	mm
Number of pixels	1920(H) × 360(V) (1 pixel = R + G + B dots)	pixels
Back-light	Up edge side 1-LED Light bar Type	

### 10.2 Mounting

See FIGURE 5. (shown in Appendix)

### 10.3 Anti-Glare and Polarizer Hardness.

The surface of the LCD has an anti-glare coating to minimize reflection and a coating to reduce scratching.

### 10.4 Light Leakage

There shall not be visible light from the back-lighting system around the edges of the screen as seen from a distance 50cm from the screen with an overhead light level of 350lux.

**11.0 RELIABILITY TEST**

The Reliability test items and its conditions are shown in below.

<Table 9. Reliability Test Parameters >

No	Test Items	Conditions	
1	High temperature storage test	Ta = 60 °C, 240 hrs	
2	Low temperature storage test	Ta = -20 °C, 240 hrs	
3	High temperature & high humidity operation test	Ta = 50 °C, 80%RH, 240hrs	
4	High temperature operation test	Ta = 50 °C, 240hrs	
5	Low temperature operation test	Ta = 0 °C, 240hrs	
6	Thermal shock	Ta = -20 °C ↔ 60 °C (0.5 hr), 100 cycle	
7	Vibration test (non-operating)	Frequency	10 ~ 300 Hz, Sweep rate 30 min
		Gravity / AMP	1.5 G
		Period	X, Y, Z 30 min
8	Shock test (non-operating)	Gravity	50G
		Pulse width	11msec, half sine wave
		Direction	± X, ± Y, ± Z Once for each
9	Electro-static discharge test (non-operating)	Air : 150 pF, 330Ω, 15 KV	Contact : 150 pF, 330Ω, 8 KV
10	Altitude test	Operating: 0 to 15000ft , 0 to 40°	
		Non Operating: 0 to 40000ft, -10 to 25°	

## 12.0 HANDLING & CAUTIONS

- (1) Cautions when taking out the module
  - Pick the pouch only, when taking out module from a shipping package.
- (2) Cautions for handling the module
  - As the electrostatic discharges may break the LCD module, handle the LCD module with care. Peel a protection sheet off from the LCD panel surface as slowly as possible.
  - As the LCD panel and back - light element are made from fragile glass material, impulse and pressure to the LCD module should be avoided.
  - As the surface of the polarizer is very soft and easily scratched, use a soft dry cloth without chemicals for cleaning.
  - Do not pull the interface connector in or out while the LCD module is operating.
  - Put the module display side down on a flat horizontal plane.
  - Handle connectors and cables with care.
- (3) Cautions for the operation
  - When the module is operating, do not lose CLK, ENAB signals. If any one of these signals is lost, the LCD panel would be damaged.
  - Obey the supply voltage sequence. If wrong sequence is applied, the module would be damaged.
- (4) Cautions for the atmosphere
  - Dew drop atmosphere should be avoided.
  - Do not store and/or operate the LCD module in a high temperature and/or humidity atmosphere. Storage in an electro-conductive polymer packing pouch and under relatively low temperature atmosphere is recommended.
- (5) Cautions for the module characteristics
  - Do not apply fixed pattern data signal to the LCD module at product aging.
  - Applying fixed pattern for a long time may cause image sticking.
- (6) Other cautions
  - Do not disassemble and/or re-assemble LCD module.
  - Do not re-adjust variable resistor or switch etc.
  - When returning the module for repair or etc., Please pack the module not to be broken. We recommend to use the original shipping packages.

### 13.0 PRODUCT SERIAL NUMBER



产品标签空白，所有内容打印添加，规格40mm\*12mm

产品ID标签说明

- ① MODEL : FG-Code前11位
- ② Module ID条形码
- ③ Module ID 17位

1-2	3	4	5-6	7	8-11	12-17
产品 GBN	产品 Grade	Line	Year	Month	Revision Code	Serial Number
			Last Two Bits of Year	1-9 , ABC		0-9 , A-F

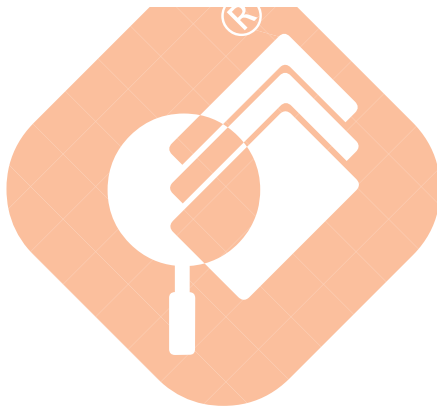



## 14.0 Packing

### 14.1 Packing Order

将MDL放入防尘袋内，并用防尘袋自带双面胶封口。**产品PCB侧朝下，封口胶带置于产品金属背板侧。**  
1 MDL/ Bag

将Bottom缓冲材放置于箱底，**放置方式详见Cushion Instructions。**

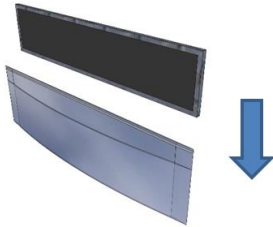

Step 1

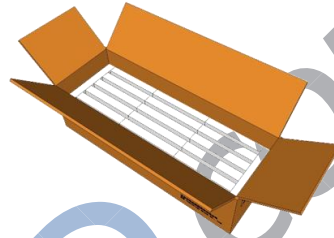

Step 2

降装好防尘袋的产品垂直插入缓冲Bottom内。**产品PCB侧朝上。**  
5 MDL/Inner Box

加盖缓冲Cover。

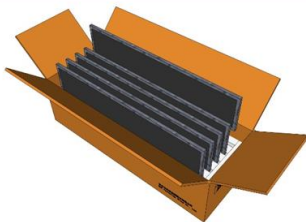

Step 3

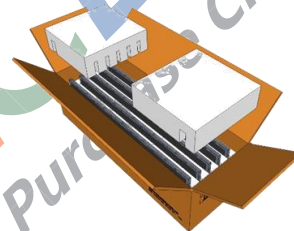

Step 4

采用“H”形封箱方式，对Box进行封箱，并在Box的Mark处粘贴相应标签。  
5 MDL/Inner Box

按如下图片所示对Inner Box进行码拍。  
16 Inner Box/Pallet

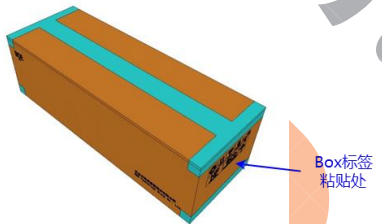

Step 5

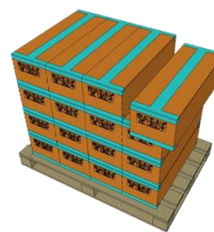

Step 6

套上Outer Box和Top Cover，用打包带打包，并粘贴相应标签。  
80 MDL/Pallet

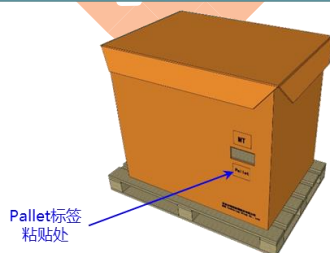

Step 7

### 14.2 Packing Note

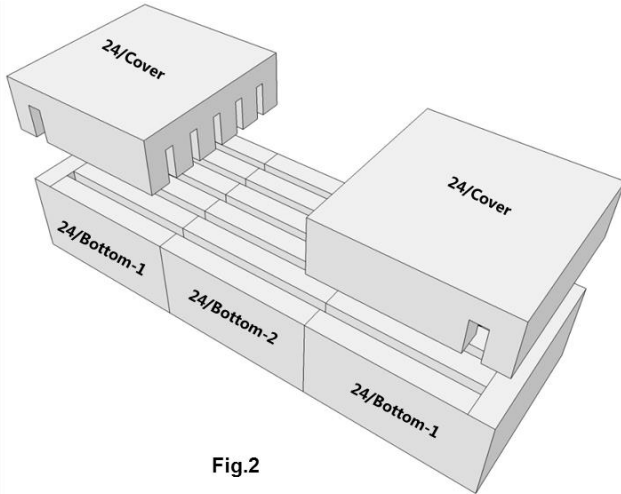

Fig.2

- 盛装24FHD MDL
- Bottom-1使用数量：2ea/Inner Box
- Bottom-2使用数量：1ea/Inner Box
- Cover使用数量：2ea/Inner Box
- 装配方式如图Fig.2

### 14.3 Box label

数量：1 Label/Box



Remark：标签粘贴时请按Box左侧Mark框的左上角为基准。

数量：1 Label/Pallet

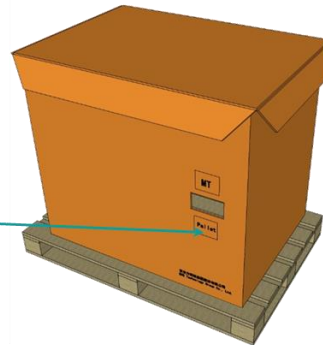
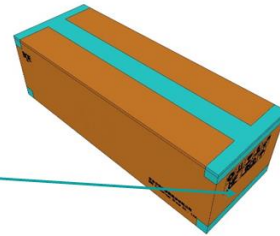

### 15.0 APPENDIX

**Figure 1. Measurement Set Up**

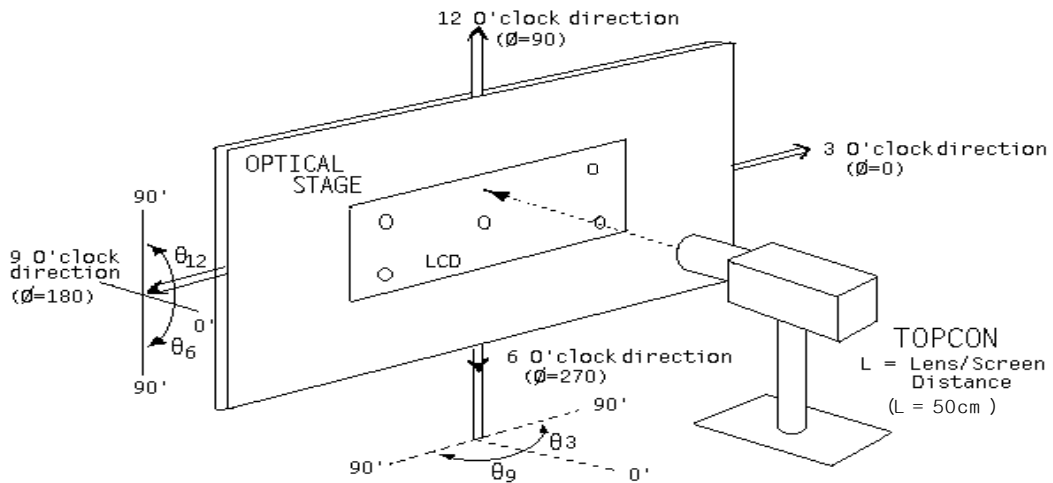

**Figure 2. White Luminance and Uniformity Measurement Locations (9 points)**

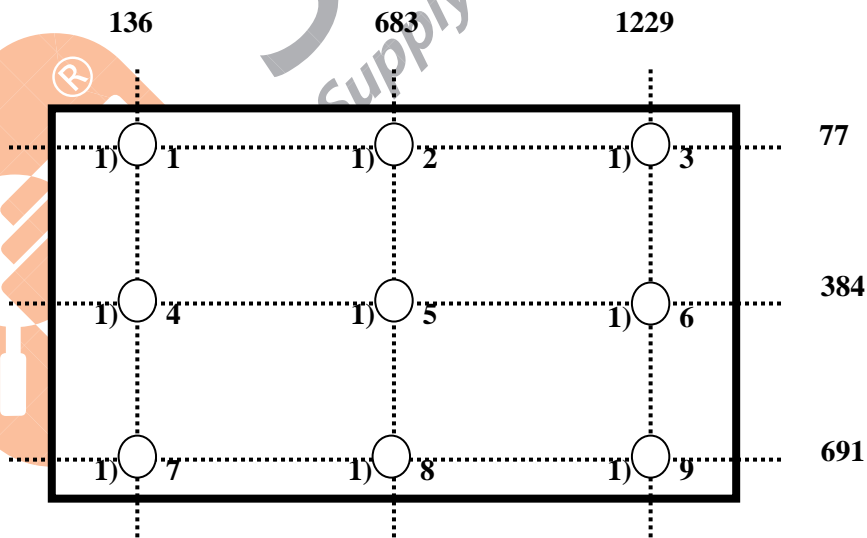

### Figure 3. Response Time Testing



### Figure 4. Cross Modulation Test Description

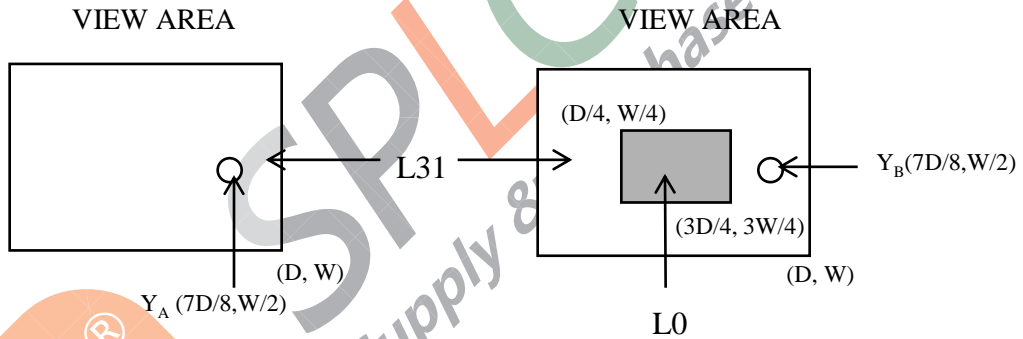

$$\text{Cross-Talk (\%)} = \left| \frac{Y_B - Y_A}{Y_A} \right| \times 100$$

Where:  $Y_A$  = Initial luminance of measured area (cd/m<sup>2</sup>)  
 $Y_B$  = Subsequent luminance of measured area (cd/m<sup>2</sup>)  
 The location measured will be exactly the same in both patterns

**Figure 5. TFT-LCD Module Outline Dimensions (Front view)**

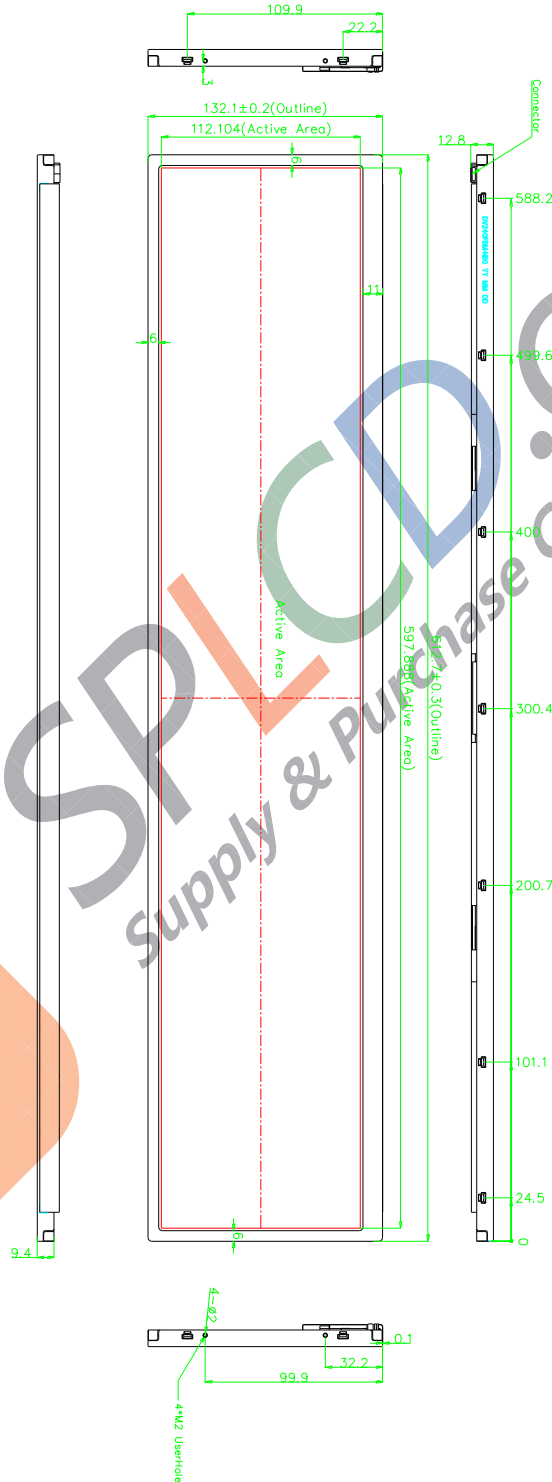

**Figure 6. TFT-LCD Module Outline Dimensions (Rear view)**

