

Technical Data

DV74ACT08 Available Q2, 1995

Quad 2-Input AND Gate

This device contains four independent 2-input AND gates.

- Advanced very high speed CMOS
- Outputs source/sink 24 mA
- Transmission line driving 50 ohms
- ACT has TTL compatible inputs
- AC device operation guaranteed from 2 to 6 volts
- DC & AC Parameters guaranteed over -40 to $+85^{\circ}\text{C}$

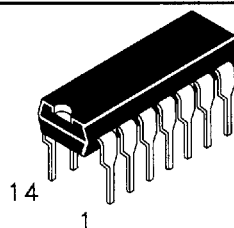
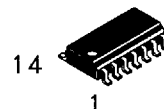
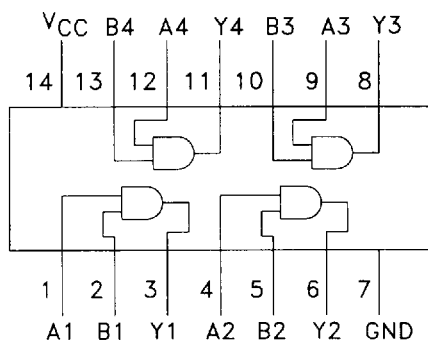
DV74AC08
DV74ACT08N Suffix
Plastic DIP
AVG-001 CaseD Suffix
Plastic SOP
AVG-002 Case**TRUTH TABLE**

Inputs		Outputs
A	B	Y
L	L	L
L	H	L
H	L	L
H	H	H

H=High Logic Level
L=Low Logic Level**ABSOLUTE MAXIMUM RATINGS**

Maximum ratings are those values beyond which damage to the device may occur.

Symbol	Parameter	AC08, ACT08	Unit
V _{CC}	DC Supply Voltage (Referenced to GND)	- 0.5 to +7.0	V
V _{IN}	DC Input Voltage (Referenced to GND)	- 0.5 to V _{CC} +0.5	V
V _{OUT}	DC Output Voltage (Referenced to GND)	- 0.5 to V _{CC} +0.5	V
I _{IN}	DC Input Current, per Pin	± 20	mA
I _{OUT}	DC Output Sink/Source Current, per Pin	± 50	mA
I _{CC}	DC V _{CC} or GND Current per Output Pin	± 50	mA
T _{stg}	Storage Temperature	- 65 to +150	°C

GUARANTEED OPERATING CONDITIONS

Symbol	Parameter	Min	Typ	Max	Unit	
V _{CC}	Supply Voltage	'AC	2.0	5.0	6.0	V
		'ACT	4.5	5.0	5.5	
V _{IN} , V _{OUT}	DC Input Voltage, Output Voltage, (Ref. to GND)	0		V _{CC}	V	
t _r , t _f	Input Rise and Fall Time (Note 1) 'AC Devices	V _{CC} @ 3.0 V		150	ns/V	
		V _{CC} @ 4.5 V		40	ns/V	
		V _{CC} @ 5.5 V		25	ns/V	
t _r , t _f	Input Rise and Fall Time (Note 2) 'ACT Devices	V _{CC} @ 4.5 V		10	ns/V	
		V _{CC} @ 5.5 V		8.0	ns/V	

GUARANTEED OPERATING CONDITIONS (continued)

Symbol	Parameter	Min	Typ	Max	Unit
T _A	Operating Ambient Temperature Range	-40		85	°C
C _{IN}	Input Capacitance V _{CC} = 5.0 V	V _{CC} = 5.0 V	4.5		pF
C _{PD}	Power Dissipation Capacitance	V _{CC} = 5.0 V	20		pF

1. V_{IN} from 30% to 70% V_{CC}2. V_{IN} from 0.8 to 2.0 V**AC — 08****DC ELECTRICAL CHARACTERISTICS**

Symbol	Parameter	Conditions	V _{CC} (V)	AC08			Unit
				T _A = +25°C		T _A = -40 to +85°C	
				Typ	Guaranteed Limits		
V _{IH}	Minimum High Level Input Voltage	V _{OUT} = 0.1V or V _{CC} - 0.1 V	3.0	1.5	2.1	2.1	V
			4.5	2.25	3.15	3.15	
			5.5	2.75	3.85	3.85	
V _{IL}	Maximum Low Level Input Voltage	V _{OUT} = 0.1V or V _{CC} - 0.1 V	3.0	1.5	0.9	0.9	V
			4.5	2.25	1.35	1.35	
			5.5	2.75	1.65	1.65	
V _{OH}	Minimum High Level Output Voltage	I _{OUT} = -50 μA	3.0	2.99	2.9	2.9	V
			4.5	4.49	4.4	4.4	
			5.5	5.49	5.4	5.4	
			V _{IN} = V _{IL} or V _{IH}				
		-12mA	3.0		2.56	2.46	V
	I _{OH}	-24mA	4.5		3.86	3.76	
		-24mA	5.5		4.86	4.76	
V _{OL}	Maximum Low Level Output Voltage	I _{OUT} = 50 μA	3.0	0.002	0.1	0.1	V
			4.5	0.001	0.1	0.1	
			5.5	0.001	0.1	0.1	
			V _{IN} = V _{IL} or V _{IH}				
		12mA	3.0		0.36	0.44	V
	I _{OL}	24mA	4.5		0.36	0.44	
		24mA	5.5		0.36	0.44	
I _{IN}	Maximum Input Leakage Current	V _{IN} = V _{CC} or GND	5.5		±0.1	±1.0	μA
I _{CC}	Maximum Quiescent Supply Current	V _{IN} = V _{CC} or GND	5.5		4.0	40	μA

AC CHARACTERISTICS over full operating conditions

Symbol	Parameter	V _{CC} ±10% (V)	AC08				Unit
			T _A = +25°C C _L = 50 pF		T _A = -40°C to +85°C C _L = 50 pF		
			Min	Max	Min	Max	
t _{PLH}	Propagation Delay	3.3	1.5	9.5	1.0	10.0	ns
		5.0	1.5	7.5	1.0	8.5	
t _{PHL}	Propagation Delay	3.3	1.5	8.5	1.0	9.0	ns
		5.0	1.5	7.0	1.0	7.5	

DC ELECTRICAL CHARACTERISTICS

Symbol	Parameter	Conditions	V _{CC} (V)	ACT08			Unit
				TA = +25°C		TA = -40 to +85°C	
				Typ	Guaranteed Limits		
V _{IH}	Minimum High Level Input Voltage	V _{OUT} = 0.1V or V _{CC} - 0.1 V	4.5	1.5	2.0	2.0	V
			5.5	1.5	2.0	2.0	
V _{IL}	Maximum Low Level Input Voltage	V _{OUT} = 0.1V or V _{CC} - 0.1 V	4.5	1.5	0.8	0.8	V
			5.5	1.5	0.8	0.8	
V _{OH}	Minimum High Level Output Voltage	I _{OUT} = -50 μA	4.5	4.49	4.4	4.4	V
			5.5	5.49	5.4	5.4	
			V _{IN} = V _{IL} or V _{IH} I _{OH} -24mA -24 mA	4.5		3.86	
5.5		4.86	4.76				
V _{OL}	Maximum Low Level Output Voltage	I _{OUT} = 50 μA	4.5	0.001	0.1	0.1	V
			5.5	0.001	0.1	0.1	
			V _{IN} = V _{IL} or V _{IH} I _{OL} 24mA 24 mA	4.5		0.36	
5.5		0.36	0.44				
I _{IN}	Maximum Input Leakage Current	V _{IN} = V _{CC} or GND	5.5		±0.1	±1.0	μA
ΔI _{CC}	Additional Max I _{CC} /Input	V _{IN} = V _{CC} - 2.1 V	5.5	0.6		1.5	mA
I _{CC}	Maximum Quiescent Supply Current	V _{IN} = V _{CC} or GND	5.5		4.0	40	μA

AC CHARACTERISTICS over full operating conditions

Symbol	Parameter	V _{CC} ±10% (V)	ACT08				Unit
			TA = +25°C C _L = 50 pF		TA = -40°C to +85°C C _L = 50 pF		
			Min	Max	Min	Max	
t _{PLH}	Propagation Delay	5.0	1.0	9.0	1.0	10.0	ns
t _{PHL}	Propagation Delay	5.0	1.0	9.0	1.0	10.0	ns

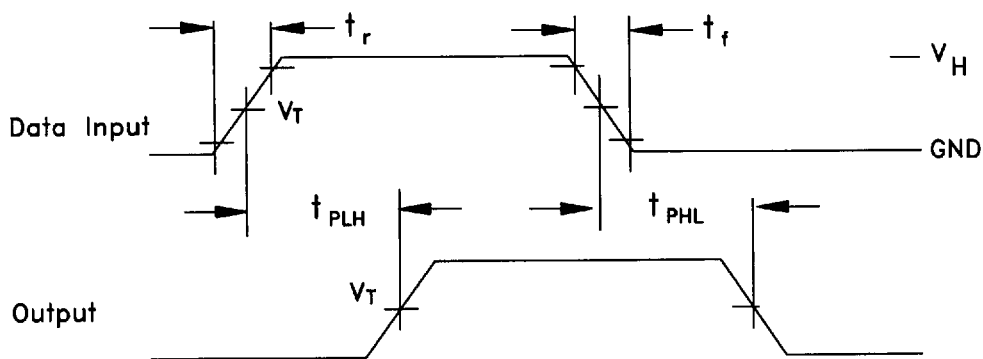
SWITCHING WAVEFORMS

Input and output threshold voltage:
 $V_T = 50\% V_{CC}$ for AC; 1.5V for ACT
 $V_H = V_{CC}$ for AC, 3V for ACT