

**Technical Data**

DV74ACT14 Available Q2, 1995

**Hex Inverter Schmitt Trigger**

This inverter is identical in pinout to the LS14, LS04, and HC04. The inputs are compatible with standard CMOS outputs. With pullup resistors, they are compatible with LSTTL outputs. This device is used in applications to "square up" slow input rise and fall times. Excellent in noisy environments due to the hysteresis voltage of the Schmitt trigger.

- **Advanced very high speed CMOS**
- **Outputs source/sink 24 mA**
- **Transmission line driving 50 ohms**
- **ACT has TTL compatible inputs**
- **AC device operation guaranteed from 2 to 6 volts**
- **DC & AC Parameters guaranteed over -40 to +85°C**

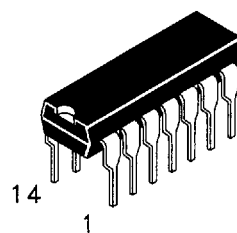
**DV74AC14  
DV74ACT14**

N Suffix  
Plastic DIP  
AVG-001 Case

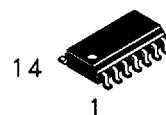

D Suffix  
Plastic SOP  
AVG-002 Case

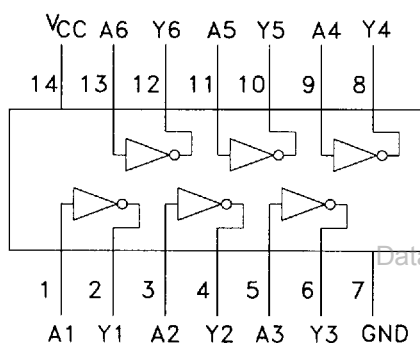
**TRUTH TABLE**

Input	Output
A	Y
L	H
H	L

H=High Logic Level  
L=Low Logic Level

**ABSOLUTE MAXIMUM RATINGS**

Maximum ratings are those values beyond which damage to the device may occur.

Symbol	Parameter	AC14, ACT14	Unit
V <sub>CC</sub>	DC Supply Voltage (Referenced to GND)	- 0.5 to +7.0	V
V <sub>IN</sub>	DC Input Voltage (Referenced to GND)	- 0.5 to V <sub>CC</sub> +0.5	V
V <sub>OUT</sub>	DC Output Voltage (Referenced to GND)	- 0.5 to V <sub>CC</sub> +0.5	V
I <sub>IN</sub>	DC Input Current, per Pin	± 20	mA
I <sub>OUT</sub>	DC Output Sink/Source Current, per Pin	± 50	mA
I <sub>CC</sub>	DC V <sub>CC</sub> or GND Current per Output Pin	± 50	mA
T <sub>stg</sub>	Storage Temperature	- 65 to +150	°C

**GUARANTEED OPERATING CONDITIONS**

Symbol	Parameter	Min	Typ	Max	Unit	
V <sub>CC</sub>	Supply Voltage	'AC	2.0	5.0	6.0	V
		'ACT	4.5	5.0	5.5	
V <sub>IN</sub> , V <sub>OUT</sub>	DC Input Voltage, Output Voltage, (Ref. to GND)	0		V <sub>CC</sub>	V	
T <sub>A</sub>	Operating Ambient Temperature Range	-40	25	85	°C	
C <sub>IN</sub>	Input Capacitance V <sub>CC</sub> = 5.0 V		4.5		pF	
C <sub>PD</sub>	Power Dissipation Capacitance V <sub>CC</sub> = 5.0 V		25		pF	

## DC ELECTRICAL CHARACTERISTICS

Symbol	Parameter	Conditions	V <sub>CC</sub> (V)	AC14			Unit		
				T <sub>A</sub> = +25°C		T <sub>A</sub> = -40 to +85°C			
				Typ	Guaranteed Limits				
V <sub>T+</sub>	Maximum Positive Threshold		3.0	2.2			V		
			4.5	3.2					
			5.5	3.9					
V <sub>T-</sub>	Minimum Negative Threshold		3.0	0.5			V		
			4.5	0.9					
			5.5	1.1					
V <sub>H</sub>	Minimum Input Hysteresis		3.0	0.3			V		
			4.5	0.4					
			5.5	0.5					
V <sub>OH</sub>	Minimum High Level Output Voltage	I <sub>OUT</sub> = -50 μA	3.0	2.99	2.9	2.9	V		
			4.5	4.49	4.4	4.4			
			5.5	5.49	5.4	5.4			
		V <sub>IN</sub> = V <sub>IL</sub> or V <sub>IH</sub>	I <sub>OH</sub>	-12mA	3.0		2.56	2.46	V
				-24mA	4.5		3.86	3.76	
				-24mA	5.5		4.86	4.76	
V <sub>OL</sub>	Maximum Low Level Output Voltage	I <sub>OUT</sub> = 50 μA	3.0	0.002	0.1	0.1	V		
			4.5	0.001	0.1	0.1			
			5.5	0.001	0.1	0.1			
		V <sub>IN</sub> = V <sub>IL</sub> or V <sub>IH</sub>	I <sub>OL</sub>	12mA	3.0		0.36	0.44	V
				24mA	4.5		0.36	0.44	
				24mA	5.5		0.36	0.44	
I <sub>IN</sub>	Maximum Input Leakage Current	V <sub>IN</sub> = V <sub>CC</sub> or GND	5.5		±0.1	±1.0	μA		
I <sub>CC</sub>	Maximum Quiescent Supply Current	V <sub>IN</sub> = V <sub>CC</sub> or GND	5.5		4.0	40	μA		

## AC CHARACTERISTICS over full operating conditions

Symbol	Parameter	V <sub>CC</sub> ±10% (V)	AC14				Unit
			T <sub>A</sub> = +25°C C <sub>L</sub> = 50 pF		T <sub>A</sub> = -40°C to +85°C C <sub>L</sub> = 50 pF		
			Min	Max	Min	Max	
t <sub>PLH</sub>	Propagation Delay	3.3	1.5	13.5	1.5	15.0	ns
		5.0	1.5	10.0	1.5	11.0	
t <sub>PHL</sub>	Propagation Delay	3.3	1.5	11.5	1.5	13.0	ns
		5.0	1.5	8.5	1.5	9.5	

## DC ELECTRICAL CHARACTERISTICS

Symbol	Parameter	Conditions	V <sub>CC</sub> (V)	ACT14			Unit
				T <sub>A</sub> = +25°C		T <sub>A</sub> = -40 to +85°C	
				Typ	Guaranteed Limits		
V <sub>T+</sub>	Maximum Positive Threshold		4.5	2.0			V
V <sub>T-</sub>	Minimum Negative Threshold		4.5	0.8			V
V <sub>H</sub>	Minimum Input hysteresis		4.5	0.4			V
V <sub>OH</sub>	Minimum High Level Output Voltage	I <sub>OUT</sub> = -50 μA	4.5	4.49	4.4	4.4	V
			5.5	5.49	5.4	5.4	
		V <sub>IN</sub> = V <sub>IL</sub> or V <sub>IH</sub> I <sub>OH</sub> = -24 mA	4.5		3.86	3.76	V
			5.5		4.86	4.76	
V <sub>OL</sub>	Maximum Low Level Output Voltage	I <sub>OUT</sub> = 50 μA	4.5	0.001	0.1	0.1	V
			5.5	0.001	0.1	0.1	
		V <sub>IN</sub> = V <sub>IL</sub> or V <sub>IH</sub> I <sub>OL</sub> = 24 mA	4.5		0.36	0.44	V
			5.5		0.36	0.44	
I <sub>IN</sub>	Maximum Input Leakage Current	V <sub>IN</sub> = V <sub>CC</sub> or GND	5.5		±0.1	±1.0	μA
ΔI <sub>CC</sub>	Additional Max I <sub>CC</sub> /Input	V <sub>IN</sub> = V <sub>CC</sub> - 2.1 V	5.5	0.6		1.5	mA
I <sub>CC</sub>	Maximum Quiescent Supply Current	V <sub>IN</sub> = V <sub>CC</sub> or GND	5.5		4.0	40	μA

DataSheet4U.com

## AC CHARACTERISTICS over full operating conditions

Symbol	Parameter	V <sub>CC</sub> ±10% (V)	ACT14				Unit
			T <sub>A</sub> = +25°C C <sub>L</sub> = 50 pF		T <sub>A</sub> = -40°C to +85°C C <sub>L</sub> = 50 pF		
			Min	Max	Min	Max	
t <sub>PLH</sub>	Propagation Delay	5.0	1.5	11.5	1.0	12.5	ns
t <sub>PHL</sub>	Propagation Delay	5.0	1.5	10.0	1.0	11.0	ns

## SWITCHING WAVEFORMS

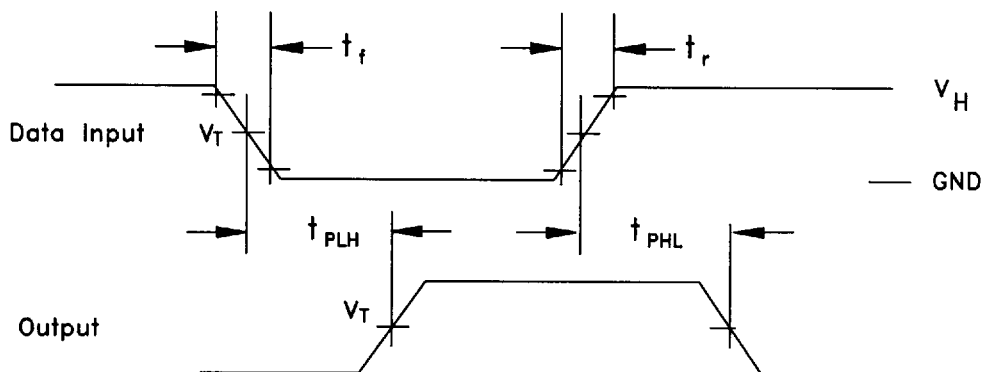

Input and output threshold voltage:  
V<sub>T</sub> = 50% V<sub>CC</sub> for AC; 1.5V for ACT  
V<sub>H</sub> = V<sub>CC</sub> for AC, 3V for ACT

www.DataSheet4U.com