

HIGH RELIABILITY HYBRID DC-DC CONVERTERS

DESCRIPTION

The DVHE series of high reliability DC-DC converters is operable over the full military (-55 °C to +125 °C) temperature range with no power derating. Operating at a fixed frequency, these regulated, isolated units utilize well controlled undervoltage lockout circuitry to eliminate slow start-up problems.

The DVHE is optimized for low voltage applications with high efficiency synchronous rectification and fast transient response.

These converters are designed and manufactured in a facility qualified to ISO9001 and certified to MIL-PRF-38534 and MIL-STD-883.

This product may incorporate one or more of the following U.S. patents:

5,784,266
5,790,389
5,963,438
5,999,433
6,005,780
6,084,792
6,118,673

FEATURES

- High Efficiency, Up to 90%
- Low Output Voltage Models
- Up to 50 Watts Output Power
- Up to 10 Amps Output Current
- High Reliability
- Very Low Output Noise
- Wide Input Voltage Range: 16 to 40 Volts
- Input Transient Voltage: 50 Volts for 1 sec
- Output Voltage Trim +/-10%
- NO Use of Optoisolators
- Undervoltage Lockout
- Short Circuit / Current Limit Protection
- High Power Density: > 50 W/in³
- Industry Standard Package
- Precision Seam Seal or Solder Seal Hermetic Package
- Flanged and Non-flanged Versions Available.
- Custom Versions Available
- Additional Environmental Screening Available
- Meets MIL-STD-461C and MIL-STD-461D EMC Requirements When Used With a DVMC28 EMI Filter
- MIL-PRF-38534 Element Evaluated Components

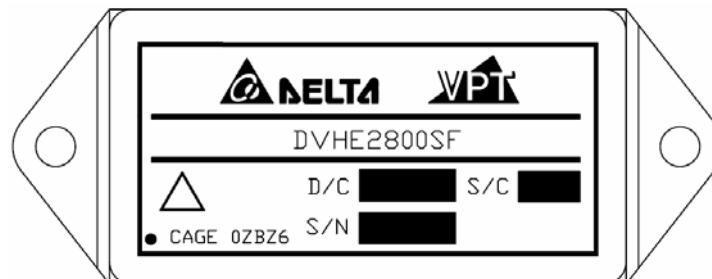

Figure 1 – DVHE2800S DC-DC Converter
(Not To Scale)

www.DataSheet4U.com

SPECIFICATIONS ($T_{CASE} = -55^{\circ}\text{C}$ to $+125^{\circ}\text{C}$, $V_{IN} = +28\text{V} \pm 5\%$, Full Load, Unless Otherwise Specified)

ABSOLUTE MAXIMUM RATINGS

Input Voltage (Continuous)	40 V_{DC}	Junction Temperature Rise to Case	+10°C
Input Voltage (Transient, 1 second)	50 Volts	Storage Temperature	-65°C to +150°C
Output Power ¹	50 Watts	Lead Solder Temperature (10 seconds)	270°C
Power Dissipation (Full Load, $T_{CASE} = +125^{\circ}\text{C}$)	9 Watts	Weight (Maximum) (Un-Flanged / Flanged)	(52 / 55) Grams

Parameter	Conditions	DVHE281R9S			DVHE282R5S			Units
		Min	Typ	Max	Min	Typ	Max	
STATIC								
INPUT Voltage ⁴	Continuous	16	28	40	16	28	40	V
	Transient, 1 sec	-	-	50	-	-	50	V
Current	Inhibited	-	-	6	-	-	6	mA
	No Load			90			90	mA
Ripple Current	Full Load, 20Hz to 10MHz			100			150	mA _{p-p}
Inhibit Pin Input ⁴		0	-	1.5	0	-	1.5	V
Inhibit Pin Open Circuit Voltage ⁴		7	9	11	7	9	11	V
UVLO Turn On		14	15	15.8	14	15	15.8	V
UVLO Turn Off ⁴		13	14	15	13	14	15	V
OUTPUT Voltage	V_{OUT} $T_{CASE} = 25^{\circ}\text{C}$	1.88	1.90	1.92	2.47	2.50	2.53	V
	V_{OUT} $T_{CASE} = -55^{\circ}\text{C}$ to $+125^{\circ}\text{C}$	1.84	1.9	1.96	2.44	2.50	2.56	V
Power ³		0		19	0		25	W
Current ³	V_{OUT}	0		10	0		10	A
Ripple Voltage	V_{OUT} Full Load, 20Hz to 10MHz			150			150	mV _{p-p}
Line Regulation	V_{OUT} $V_{IN} = 16\text{V}$ to 40V		1	10		1	10	mV
Load Regulation	V_{OUT} No Load to Full Load		15	30		15	30	mV
EFFICIENCY		80	84		83	87		%
LOAD FAULT POWER DISSIPATION	Overload ⁴			10			10	W
	Short Circuit			10			10	W
CAPACITIVE LOAD ⁴				5000			5000	μF
SWITCHING FREQUENCY		220	260	300	220	260	300	kHz
ISOLATION	500 V_{DC}	100	-	-	100	-	-	M Ω
MTBF (MIL-HDBK-217F)	AIF @ $T_C = 55^{\circ}\text{C}$	-	381	-	-	381	-	kHrs
Load Step Output Transient	V_{OUT} Half Load to Full Load	-	200	350	-	200	350	mV _{PK}
Load Step Recovery ²		-	200	300	-	200	300	μSec
Line Step Output Transient ⁴	V_{OUT} $V_{IN} = 16\text{V}$ to 40V	-	100	200	-	150	250	mV _{PK}
Line Step Recovery ^{2,4}		-	200	300	-	200	300	μSec
Turn On Delay	V_{OUT} $V_{IN} = 0\text{V}$ to 28V	-	-	30	-	-	30	mSec
Turn On Overshoot		-	-	15	-	-	15	mV _{PK}

Notes: 1. Dependant on output voltage. 2. Time for output voltage to settle within 1% of its nominal value.
3. Derate linearly to 0 at 135°C. 4. Verified by qualification testing.

SPECIFICATIONS ($T_{CASE} = -55^{\circ}\text{C}$ to $+125^{\circ}\text{C}$, $V_{IN} = +28\text{V} \pm 5\%$, Full Load, Unless Otherwise Specified)

ABSOLUTE MAXIMUM RATINGS

Input Voltage (Continuous)	40 V_{DC}	Junction Temperature Rise to Case	+10°C
Input Voltage (Transient, 1 second)	50 Volts	Storage Temperature	-65°C to +150°C
Output Power ¹	50 Watts	Lead Solder Temperature (10 seconds)	270°C
Power Dissipation (Full Load, $T_{CASE} = +125^{\circ}\text{C}$)	9 Watts	Weight (Maximum) (Un-Flanged / Flanged)	(49 / 52) Grams

Parameter	Conditions	DVHE283R3S			DVHE2805S			Units
		Min	Typ	Max	Min	Typ	Max	
STATIC								
INPUT Voltage ⁴	Continuous	16	28	40	16	28	40	V
	Transient, 1 sec	-	-	50	-	-	50	V
Current	Inhibited	-	-	6	-	-	6	mA
	No Load			110	-	-	140	mA
Ripple Current	Full Load, 20Hz to 10MHz			150	-	-	150	mA_{p-p}
Inhibit Pin Input ⁴		0	-	1.5	0	-	1.5	V
Inhibit Pin Open Circuit Voltage ⁴		7	9	11	7	9	11	V
UVLO Turn On		14	15	15.8	14	15	15.8	V
UVLO Turn Off ⁴		13	14	15	13	14	15	V
OUTPUT Voltage	V_{OUT} $T_{CASE} = 25^{\circ}\text{C}$	3.27	3.30	3.33	4.95	5.00	5.05	V
	V_{OUT} $T_{CASE} = -55^{\circ}\text{C}$ to $+125^{\circ}\text{C}$	3.22	3.30	3.38	4.87	5.00	5.13	V
Power ³		0		33	0	-	50	W
Current ³	V_{OUT}	0		10	0	-	10	A
Ripple Voltage	V_{OUT} Full Load, 20Hz to 10MHz		75	150	-	100	200	mV_{p-p}
Line Regulation	V_{OUT} $V_{IN} = 16\text{V}$ to 40V		1	10	-	1	10	mV
Load Regulation	V_{OUT} No Load to Full Load		15	30	-	15	30	mV
EFFICIENCY		85	88		86	90		%
LOAD FAULT POWER DISSIPATION	Overload ⁴			10	-	-	12	W
	Short Circuit			14	-	-	14	W
CAPACITIVE LOAD ⁴				5000	-	-	5000	μF
SWITCHING FREQUENCY		220	260	300	300	350	400	kHz
ISOLATION	500 V_{DC}	100	-	-	100	-	-	M Ω
MTBF (MIL-HDBK-217F)	AIF @ $T_C = 55^{\circ}\text{C}$	-	381	-	-	381	-	kHrs
DYNAMIC								
Load Step Output Transient	V_{OUT} Half Load to Full Load	-	200	350	-	250	400	mV_{PK}
Load Step Recovery ²			200	300	-	200	300	μSec
Line Step Output Transient ⁴	$V_{IN} = 16\text{V}$ to 40V	-	150	250	-	300	350	mV_{PK}
Line Step Recovery ^{2,4}				200	300	-	200	300
Turn On Delay	$V_{IN} = 0\text{V}$ to 28V	-	-	30	-	-	20	mSec
Turn On Overshoot				15	-	-	25	mV_{PK}

Notes: 1. Dependant on output voltage. 2. Time for output voltage to settle within 1% of its nominal value.
3. Derate linearly to 0 at 135°C. 4. Verified by qualification testing.

BLOCK DIAGRAM

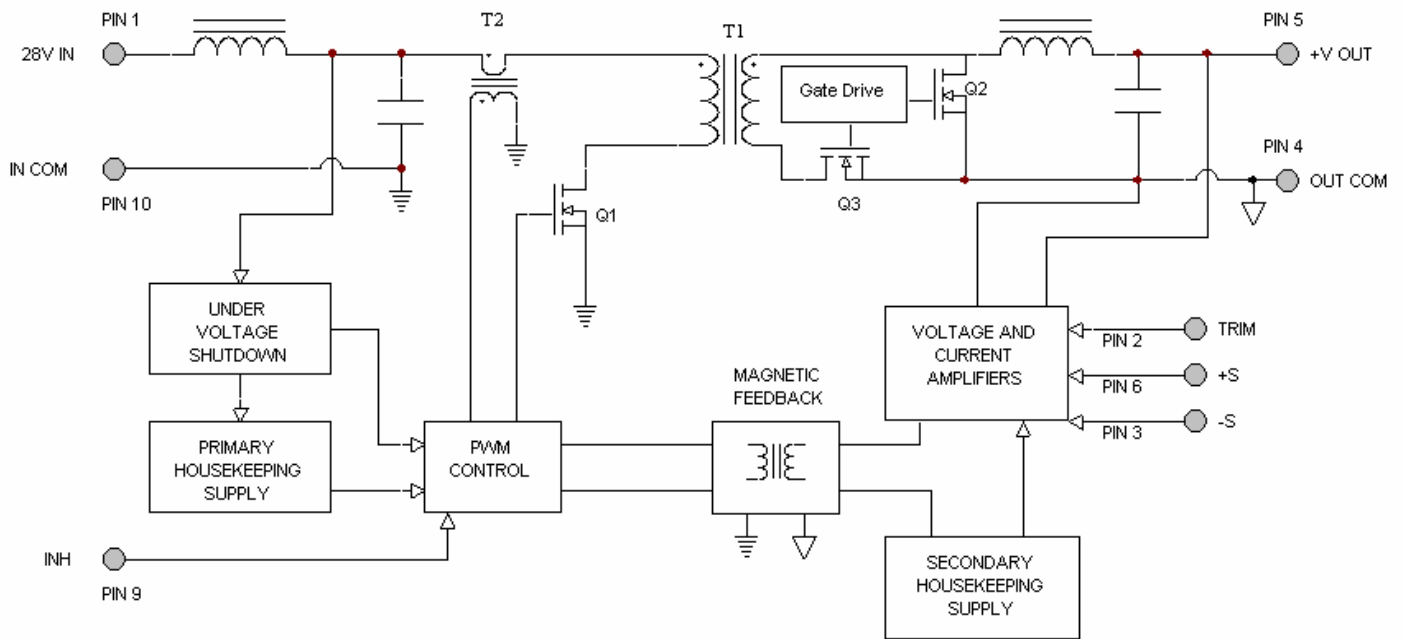

Figure 2

CONNECTION DIAGRAM

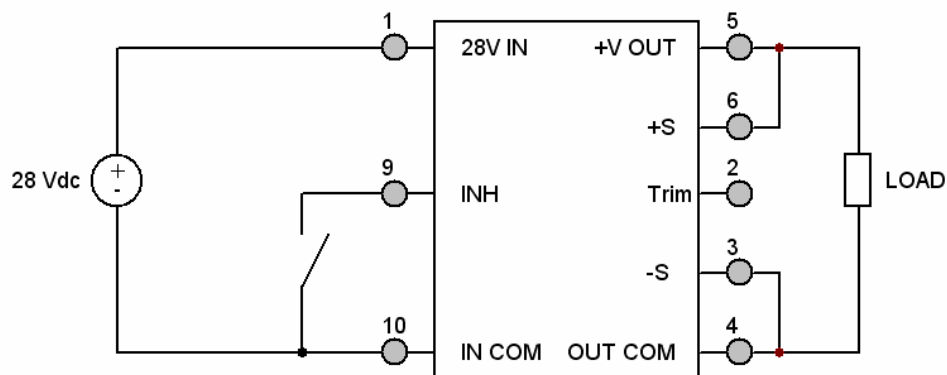

Figure 3

INHIBIT DRIVE CONNECTION DIAGRAMS

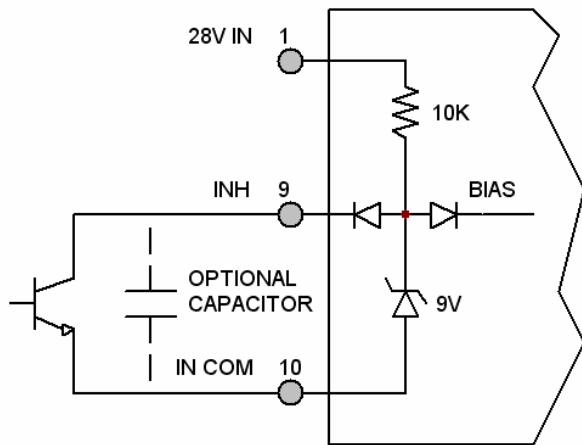

Figure 4 – Internal Inhibit Circuit and Recommended Drive
(Shown with optional capacitor for turn-on delay)

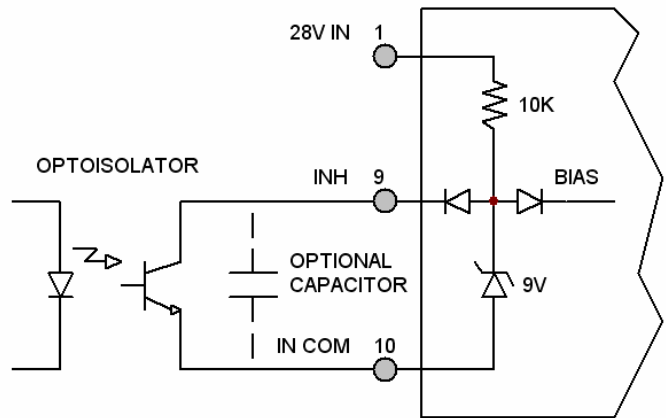

Figure 5 – Isolated Inhibit Drive
(Shown with optional capacitor for turn-on delay)

EMI FILTER HOOKUP DIAGRAM

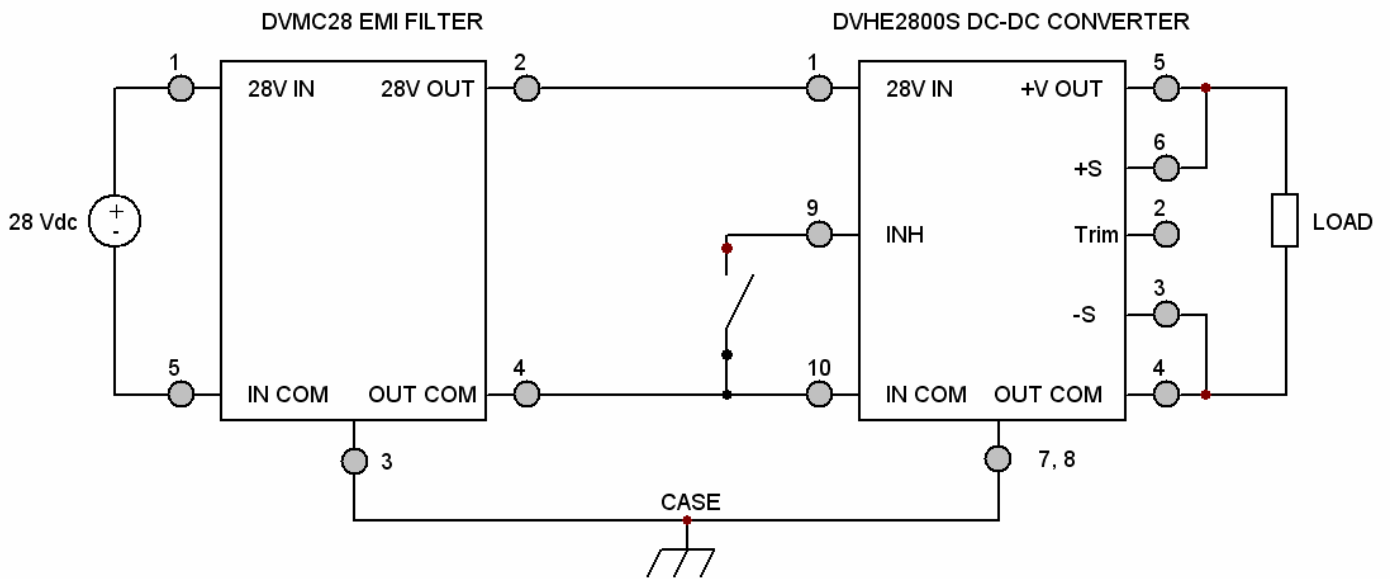
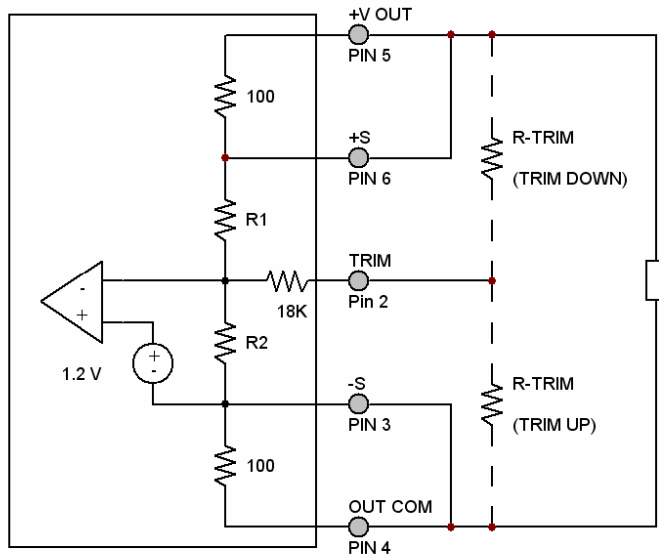

Figure 6 – Converter with EMI Filter

OUTPUT VOLTAGE TRIM



The output voltage can be trimmed down by connecting a resistor between the TRIM pin (PIN 2) and the +V OUT pin (PIN 5), or can be trimmed up by connecting a resistor between the TRIM pin (PIN 2) and the OUT COM pin (PIN 4). The maximum trim range is +10% up and -10% down. The appropriate resistor values versus the output voltage are given in the trim table below.

Figure 7 – Output Voltage Trim

DVHE281R9S		DVHE282R5S		DVHE283R3S		DVHE2805S	
+V _{OUT} (V)	R _{TRIM} (Ω)	+V _{OUT} (V)	R _{TRIM} (Ω)	+V _{OUT} (V)	R _{TRIM} (Ω)	+V _{OUT} (V)	R _{TRIM} (Ω)
1.71	11.8k	2.25	26.9k	2.97	34.8k	4.50	46.5k
1.72	14.1k	2.27	31.8k	3.00	41k	4.55	54.8k
1.74	19.6k	2.30	40.8k	3.04	51.7k	4.60	65.1k
1.76	26.7k	2.32	48.6k	3.07	62.1k	4.65	78.4k
1.78	36k	2.35	64k	3.10	75.6k	4.70	96.1k
1.80	49.2k	2.37	78.3k	3.13	93.8k	4.75	120.9k
1.82	69k	2.40	110k	3.17	131k	4.80	158k
1.84	102k	2.42	145k	3.20	179k	4.85	220k
1.86	168k	2.45	249k	3.23	268k	4.90	343.9k
1.88	365k	2.47	435k	3.27	662k	4.95	715.5k
1.90	-	2.50	-	3.30	-	5.00	-
1.92	707k	2.52	624k	3.33	392k	5.05	216.7k
1.94	345k	2.55	239k	3.36	187k	5.10	99.4k
1.96	224k	2.57	165k	3.40	105k	5.15	60.2k
1.99	143k	2.60	110k	3.43	76.7k	5.20	40.7k
2.00	127k	2.62	89k	3.46	58.9k	5.25	28.9k
2.01	114k	2.65	67.6k	3.50	43.5k	5.30	21.1k
2.03	93.6k	2.67	57.5k	3.53	35.5k	5.35	15.5k
2.05	78.7k	2.70	46.2k	3.56	29.3k	5.40	11.3k
2.07	67.4k	2.72	40.4k	3.60	23k	5.45	8k
2.10	54.5k	2.75	33.4k	3.63	19.3k	5.50	5.5k

www.DataSheet4U.com

EFFICIENCY PERFORMANCE CURVES ($T_{CASE} = 25^{\circ}C$, Full Load, Unless Otherwise Specified)

- - - - $V_{IN} = 16V$
— $V_{IN} = 28V$
- · - · - $V_{IN} = 40V$

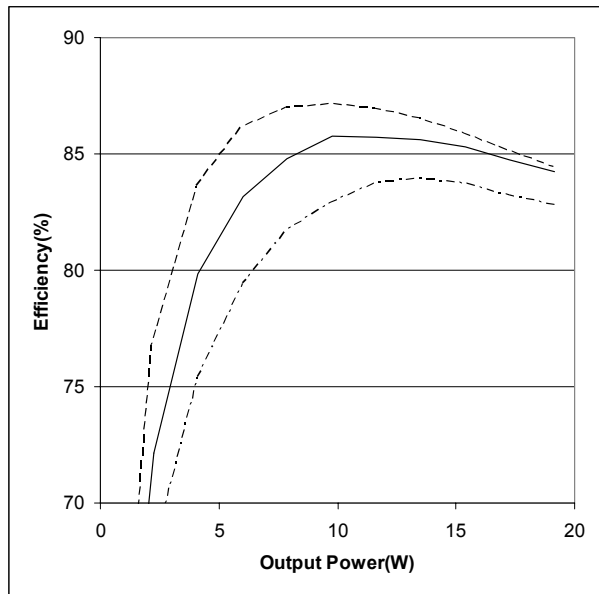

Figure 8 – DVHE281R9S
Efficiency (%) vs. Output Power (W)

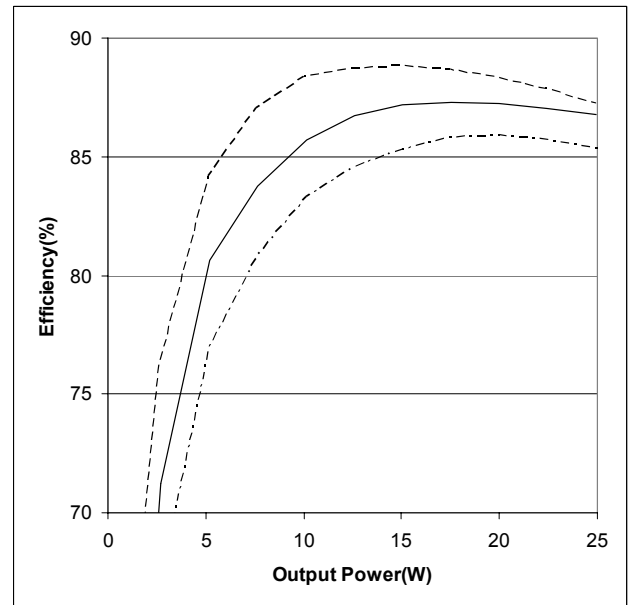

Figure 9 – DVHE282R5S
Efficiency (%) vs. Output Power (W)

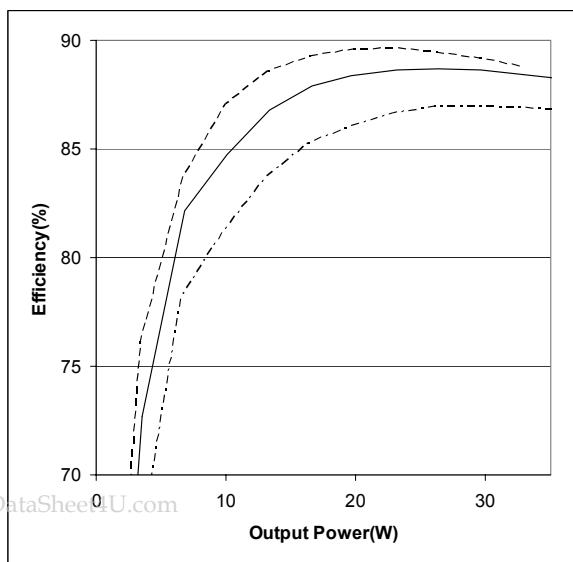

Figure 10 – DVHE283R3S
Efficiency (%) vs. Output Power (W)

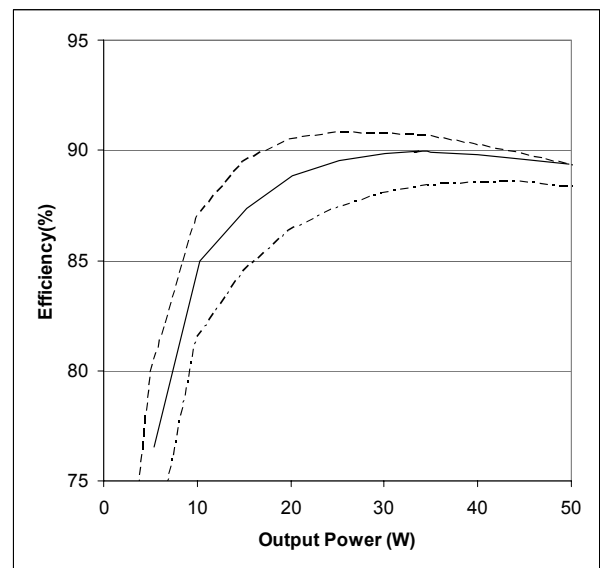

Figure 11 – DVHE2805S
Efficiency (%) vs. Output Power (W)

www.DataSheet4U.com

EMI PERFORMANCE CURVES

($T_{CASE} = 25^{\circ}C$, $V_{IN} = +28V \pm 5\%$, Full Load, Unless Otherwise Specified)

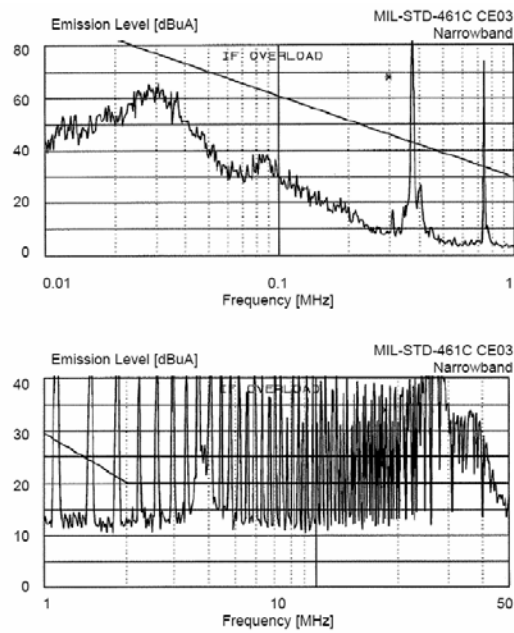

Figure 12 – DVHE2800S without EMI Filter

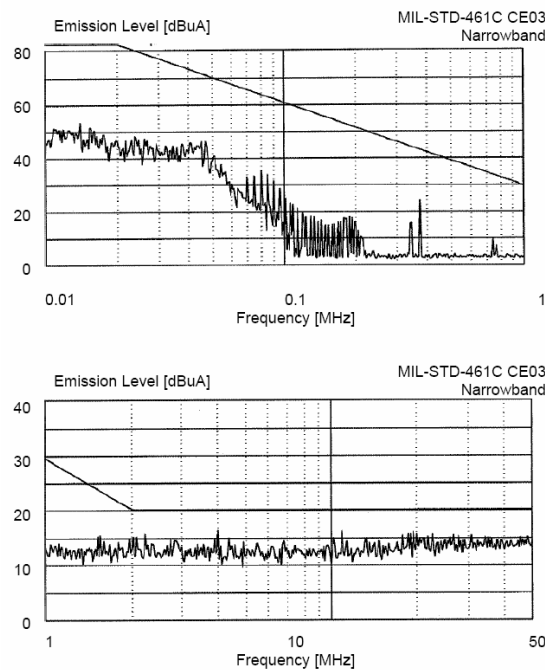
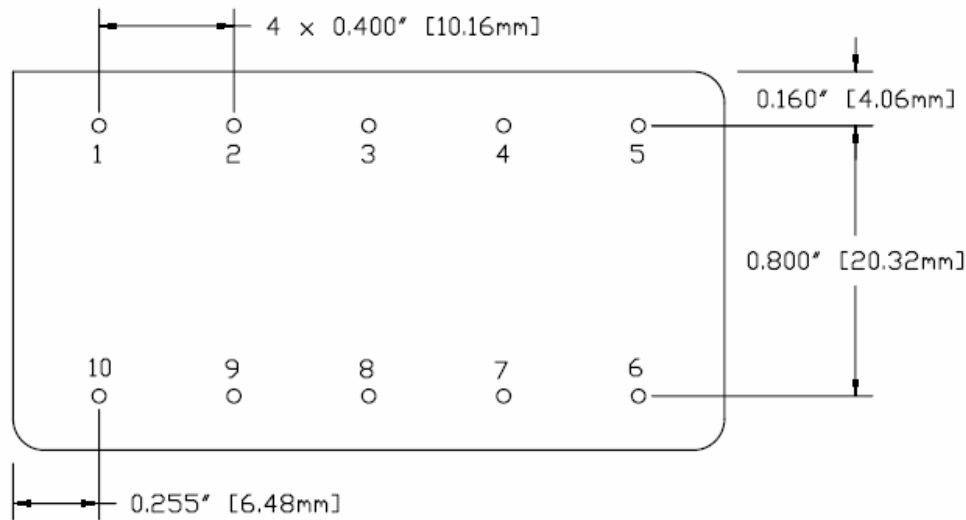
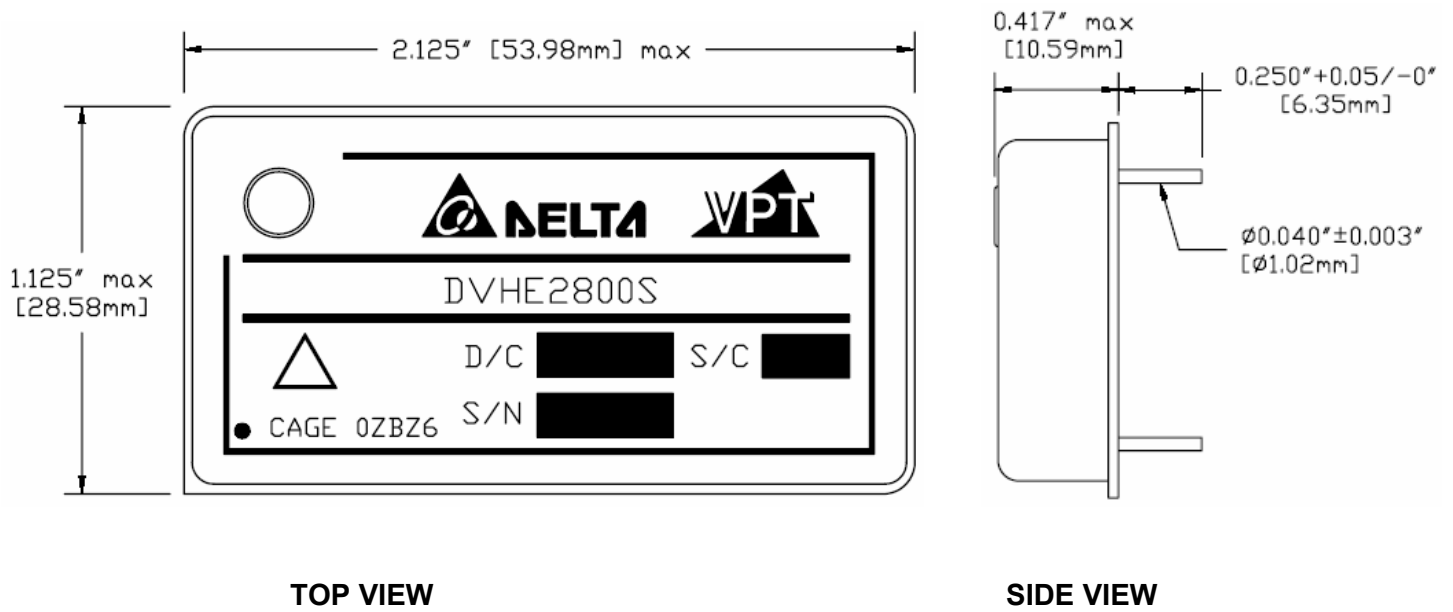

Figure 13 – DVHE2800S with DVMC28 EMI Filter

PACKAGE SPECIFICATIONS (NON-FLANGED, SOLDER SEAL)



PIN	FUNCTION
1	28V IN
2	TRIM
3	-S
4	OUT COM
5	+V OUT
6	+S
7	CASE
8	CASE
9	INHIBIT
10	IN COM

BOTTOM VIEW

www.DataSheet4U.com

Figure 14 – Non-Flanged, Solder Seal Tin Plated Package and Pinout (Not Used for /HB or Higher Screened Products)
(Dimensional Limits are ±0.005" Unless Otherwise Stated)

PACKAGE SPECIFICATIONS (NON-FLANGED, SEAM SEAL)

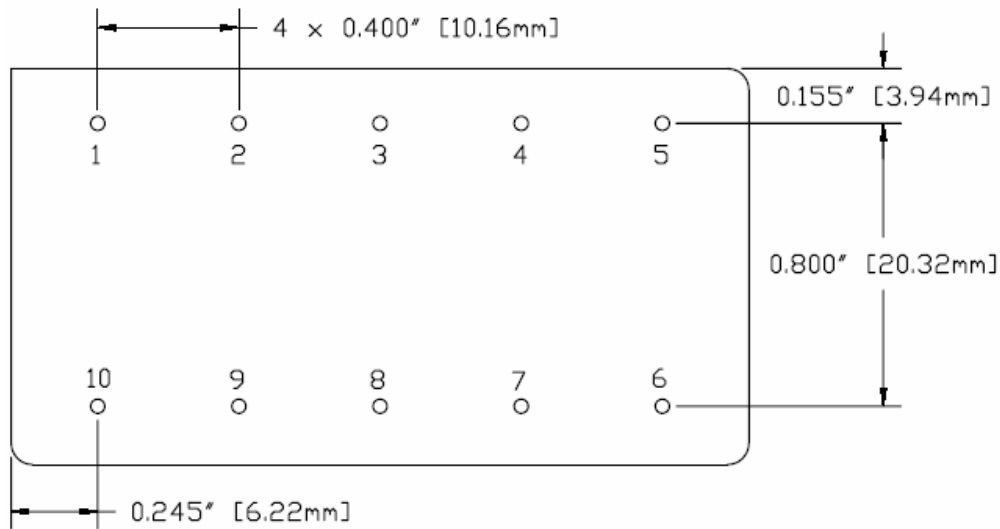
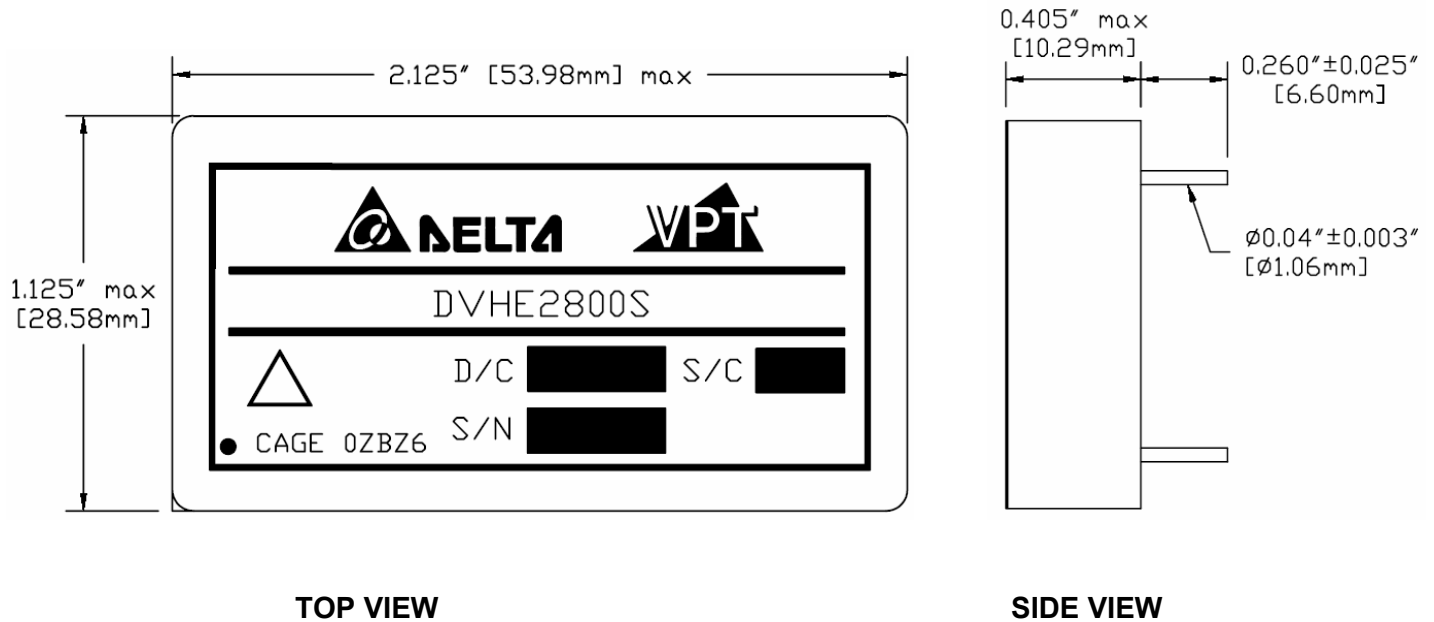

PIN	FUNCTION
1	28V IN
2	TRIM
3	-S
4	OUT COM
5	+V OUT
6	+S
7	CASE
8	CASE
9	INHIBIT
10	IN COM

BOTTOM VIEW

Figure 15 – Non-Flanged, Seam Seal Package and Pinout
(Dimensional Limits are ± 0.005 " Unless Otherwise Stated)

PACKAGE SPECIFICATIONS (FLANGED, SOLDER SEAL)

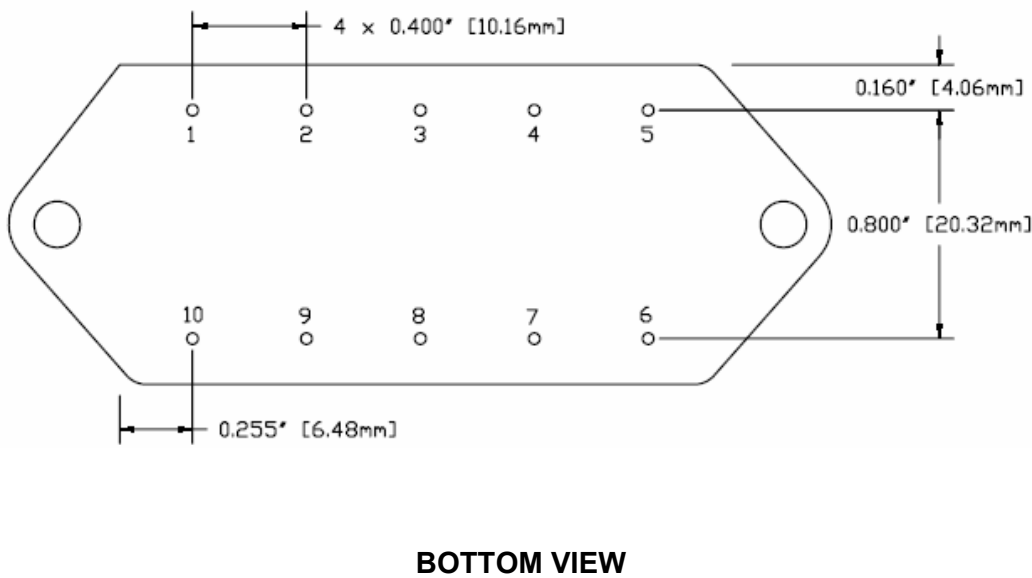
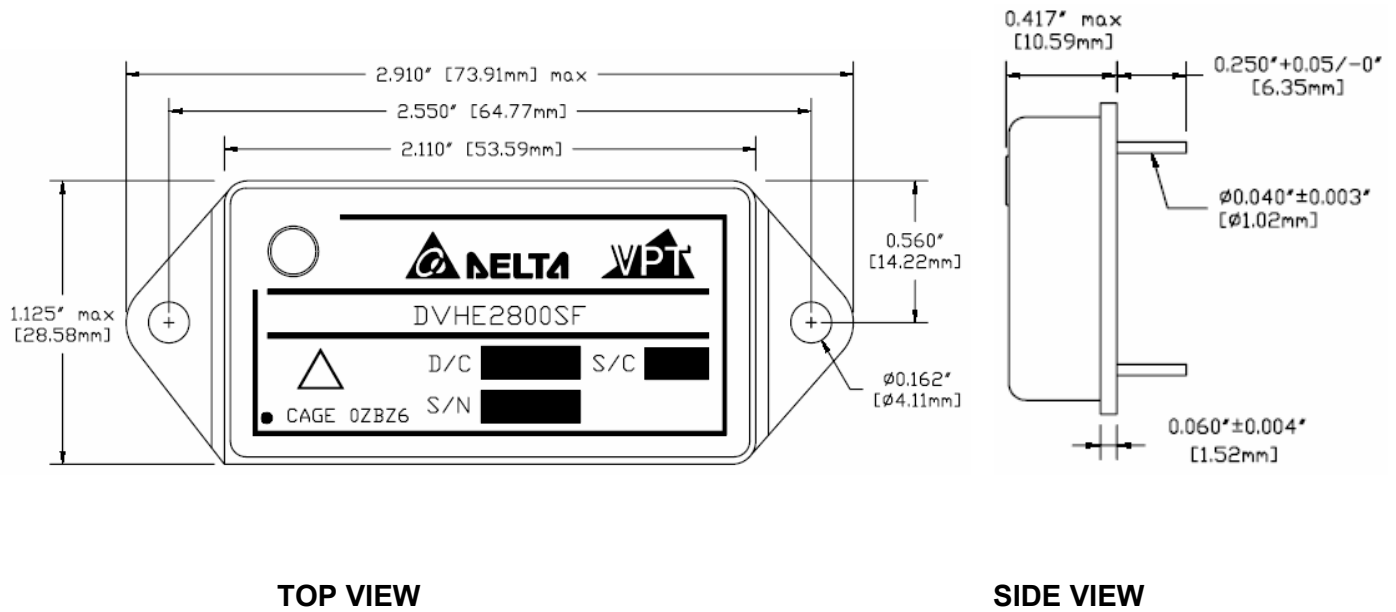

PIN	FUNCTION
1	28V IN
2	TRIM
3	-S
4	OUT COM
5	+V OUT
6	+S
7	CASE
8	CASE
9	INHIBIT
10	IN COM

www.DataSheet4U.com

Figure 16 – Flanged, Solder Seal Tin Plated Package and Pinout (Not Used for /HB or Higher Screened Products)
(Dimensional Limits are $\pm 0.005"$ Unless Otherwise Stated)

PACKAGE SPECIFICATIONS (FLANGED, SEAM SEAL)

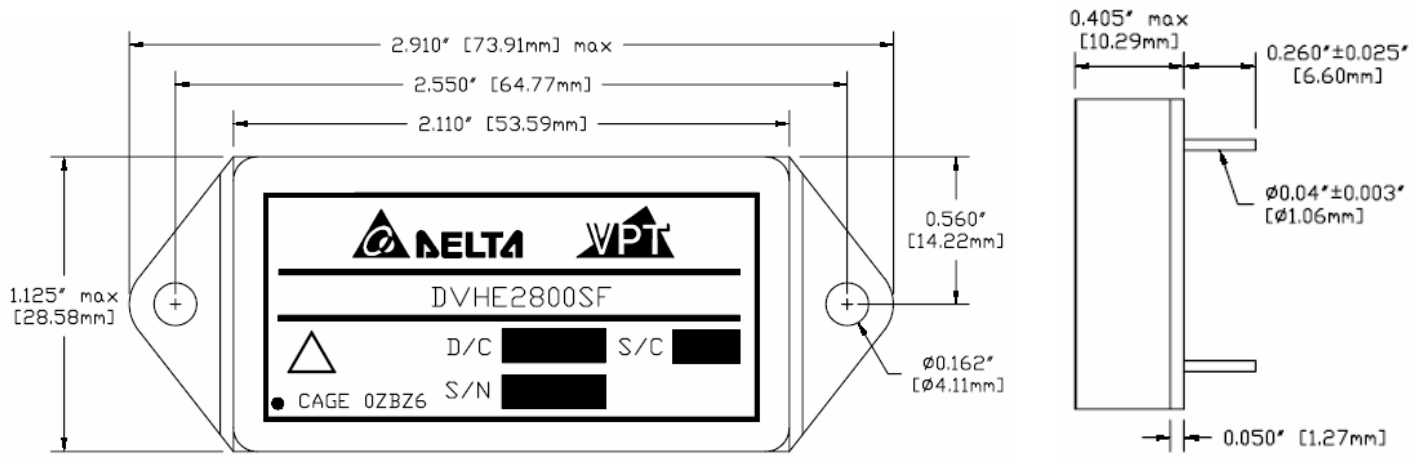

TOP VIEW

SIDE VIEW

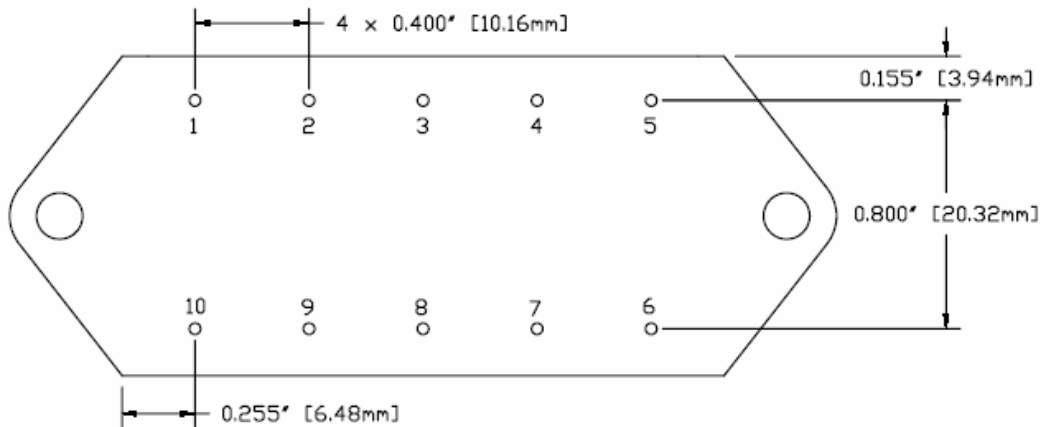

PIN	FUNCTION
1	28V IN
2	TRIM
3	-S
4	OUT COM
5	+V OUT
6	+S
7	CASE
8	CASE
9	INHIBIT
10	IN COM

Figure 17 – Flanged, Seam Seal Package and Pinout
(Dimensional Limits are $\pm 0.005"$ Unless Otherwise Stated)

PACKAGE PIN DESCRIPTION

Pin	Function	Description
1	28V IN	Positive Input Voltage Connection
2	TRIM	Trim the Output Voltage +/- 10%
3	-S	Return Sense
4	OUT COM	Output Common Connection
5	+V OUT	Positive Output Voltage Connection
6	+S	Positive Sense
7	CASE	Case Connection
8	CASE	Case Connection
9	INHIBIT	Logic Low = Disabled Output. Connecting the inhibit pin to input common causes converter shutdown. Logic High = Enabled Output. Unconnected or open collector TTL.
10	IN COM	Input Common Connection

ENVIRONMENTAL SCREENING (100% Tested Per MIL-STD-883 as referenced to MIL-PRF-38534)

Screening	MIL-STD-883	Standard (No Suffix)	Extended /ES	HB /HB	Class H /H	Class K /K
Non-Destructive Bond Pull	Method 2023	•	•	•	•	•
Internal Visual	Method 2017, 2032 Internal Procedure	•	•	•	•	•
Temperature Cycling	Method 1010, Condition C Method 1010, -55°C to 125°C		•	•	•	•
Constant Acceleration	Method 2001, 3000g, Y1 Direction Method 2001, 500g, Y1 Direction		•	•	•	•
PIND	Method 2020, Condition A ²					•
Pre Burn-In Electrical	100% at 25°C					•
Burn-In	Method 1015, 320 hours at +125°C Method 1015, 160 hours at +125°C 96 hours at +125°C 24 hours at +125°C	•	•	•	•	•
Final Electrical	MIL-PRF-38534, Group A ¹ 100% at 25°C	•	•	•	•	•
Hermeticity	Method 1014, Fine Leak, Condition A Method 1014, Gross Leak, Condition C Dip (1 x 10 ⁻³)	•	•	•	•	•
Radiography	Method 2012 ³					•
External Visual	Method 2009	•	•	•	•	•

- Notes:
1. 100% R&R testing at -55°C, +25°C, and +125°C with all test data included in product shipment.
 2. PIND test Certificate of Compliance included in product shipment.
 3. Radiographic test Certificate of Compliance and film(s) included in product shipment.

ORDERING INFORMATION

DVHE	28	05	S	F	/HB	-	XXX
1	2	3	4	5	6		7

(1)

(2)

(3)

(4)

Product Series	Nominal Input Voltage		Output Voltage		Number of Outputs	
DVHE	28	28 Volts	1R9 2R5 3R3 05	1.9 Volts 2.5 Volts 3.3 Volts 5 Volts	S	Single

(5)

(6)

(7)

Package Option		Screening Code ^{1,2}		Additional Screening Code
None F	Non-Flanged Flanged	None /ES /HB /H /K	Standard Extended HB Class H Class K	Contact Sales

- Notes:
1. Contact the VPT Inc. Sales Department for availability of Class H (/H) or Class K (/K) qualified products.
 2. VPT Inc. reserves the right to ship higher screened or SMD products to meet lower screened orders at our sole discretion unless specifically forbidden by customer contract.

Please contact your sales representative or the VPT Inc. Sales Department for more information concerning additional environmental screening and testing, different input voltage, output voltage, power requirement, source inspection, and/or special element evaluation for space or other higher quality applications.

SMD (STANDARD MICROCIRCUIT DRAWING) NUMBERS

Standard Microcircuit Drawing (SMD)	DVHE2800S Series Similar Part Number
*T.B.D.	DVHE281R9S/H DVHE281R9SF/H
*T.B.D.	DVHE282R5S/H DVHE282R5SF/H
*T.B.D.	DVHE283R3S/H DVHE283R3SF/H
*T.B.D.	DVHE2805S/H DVHE2805SF/H

Do not use the DVHE2800S Series similar part number for SMD product acquisition. It is listed for reference only. For exact specifications for the SMD product, refer to the SMD drawing. SMD's can be downloaded from the DSCC website at <http://www.dscclia.mil/programs/smcr/>. The SMD number listed above is for MIL-PRF-38534 Class H screening, standard gold plated lead finish, and no RHA (Radiation Hardness Assurance) level. Please reference the SMD for other screening levels, lead finishes, and radiation levels.

CONTACT INFORMATION

To request a quotation or place orders please contact your sales representative or the VPT Inc. Sales Department at:

Phone: (425) 353-3010
Fax: (425) 353-4030
E-mail: vptsales@vpt-inc.com

All information contained in this datasheet is believed to be accurate, however, no responsibility is assumed for possible errors or omissions. The products or specifications contained herein are subject to change without notice.