



# DVHF2800D Series

## HIGH RELIABILITY HYBRID DC-DC CONVERTERS

### DESCRIPTION

The DVHF series of high reliability DC-DC converters is operable over the full military (-55 °C to +125 °C) temperature range with no power derating. Unique to the DVHF series are robust and effective input and output filters which provide dramatically reduced input and output noise performance when compared to other manufacturers competing devices. Operating at a nominal fixed frequency of 450 kHz, these regulated, isolated units utilize a high speed magnetic feedback design and well controlled undervoltage lockout circuitry to eliminate slow start-up problems.

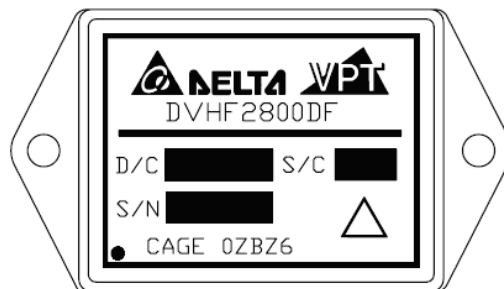
These converters are designed and manufactured in a facility qualified to ISO9001 and certified to MIL-PRF-38534 and MIL-STD-883.

This product may incorporate one or more of the following U.S. patents:

- 5,784,266
- 5,790,389
- 5,963,438
- 5,999,433
- 6,005,780
- 6,084,792
- 6,118,673

### FEATURES

- High Reliability
- Very Low Output Noise
- Wide Input Voltage Range: 15 to 50 Volts per MIL-STD-704
- Up to 20 Watts Output Power
- Fault Tolerant Magnetic Feedback Circuit
- NO Use of Optoisolators
- Undervoltage Lockout
- Indefinite Short Circuit Protection
- Current Limit Protection
- Industry Standard Pinout
- High Input Transient Voltage: 80 Volts for 1 sec per MIL-STD-704A
- Precision Projection Welded Hermetic Package
- High Power Density: > 37 W/in<sup>3</sup>
- Custom Versions Available
- Additional Environmental Screening Available
- Meets MIL-STD-461 Revisions C, D, E and F EMC Requirements When Used With VPT's EMI Filters
- Flanged and Non-flanged Versions Available.
- MIL-PRF-38534 Element Evaluated Components
- Space Applications should consider VPT's "S" Series of Radiation Tolerant Power Conversion Devices. Contact VPT for details.



**Figure 1** – DVHF2800D / DVHF2800DF DC-DC Converter  
(Exact marking may differ from that shown)

## SPECIFICATIONS (T<sub>CASE</sub> = -55°C to +125°C, V<sub>IN</sub> = +28V ± 5%, Full Load<sup>5</sup>, Unless Otherwise Specified)

### ABSOLUTE MAXIMUM RATINGS

Input Voltage (Continuous)	50 V <sub>DC</sub>	Junction Temperature Rise to Case	+12°C
Input Voltage (Transient, 1 second)	80 Volts	Storage Temperature	-65°C to +150°C
Output Power <sup>1</sup>	20 Watts	Lead Solder Temperature (10 seconds)	270°C
Power Dissipation (Full Load, T <sub>CASE</sub> = +125°C)	6 Watts	Weight (Maximum) (Un-Flanged / Flanged)	(24 / 28) Grams
ESD Rating per MIL-PRF-38534	2		

Parameter	Conditions	DVHF2805D			DVHF2812D			Units
		Min	Typ	Max	Min	Typ	Max	
<b>STATIC</b>								
INPUT Voltage <sup>4</sup>	Continuous	15	28	50	15	28	50	V
	Transient, 1 sec	-	-	80	-	-	80	V
Current	Inhibited	-	4	6	-	4	6	mA
	No Load	-	45	65	-	45	65	mA
Ripple Current	Full Load <sup>5</sup> , 20Hz to 10MHz	-	35	60	-	45	90	mA <sub>p-p</sub>
Inhibit Pin Input <sup>4</sup>		0	-	1.5	0	-	1.5	V
Inhibit Pin Open Circuit Voltage <sup>4</sup>		9.0	11.0	13.0	9.0	11.0	13.0	V
UVLO Turn On		12.0	-	14.8	12.0	-	14.8	V
UVLO Turn Off <sup>4</sup>		11.0	-	14.5	11.0	-	14.5	V
OUTPUT Voltage <sup>5</sup>	+V <sub>OUT</sub> T <sub>CASE</sub> = 25°C	4.95	5.0	5.05	11.88	12.0	12.12	V
	+V <sub>OUT</sub> T <sub>CASE</sub> = -55°C to +125°C	4.925	5.0	5.075	11.82	12.0	12.18	V
	-V <sub>OUT</sub> T <sub>CASE</sub> = 25°C	4.80	5.0	5.20	11.80	12.0	12.20	V
	-V <sub>OUT</sub> T <sub>CASE</sub> = -55°C to +125°C	4.75	5.0	5.25	11.52	12.0	12.48	V
Power <sup>3,6</sup>	Total	0	-	15	0	-	20	W
	±V <sub>OUT</sub> Either Output	0	-	10.5	0	-	14	W
Current <sup>3,6</sup>	±V <sub>OUT</sub> Either Output	0	-	2.1	0	-	1.17	A
Ripple Voltage	±V <sub>OUT</sub> Full Load <sup>5</sup> , 20Hz to 10MHz	-	35	60	-	30	50	mV <sub>p-p</sub>
Line Regulation	+V <sub>OUT</sub> V <sub>IN</sub> = 16V to 40V	-	2	20	-	2	20	mV
	-V <sub>OUT</sub> V <sub>IN</sub> = 16V to 40V	-	20	200	-	20	200	mV
Load Regulation	+V <sub>OUT</sub> No Load to Full Load <sup>5</sup>	-	5	50	-	5	50	mV
	-V <sub>OUT</sub> No Load to Full Load <sup>5,7</sup>	-	25	200	-	20	200	mV
Cross Regulation	-V <sub>OUT</sub> +V <sub>OUT</sub> = 70%, -V <sub>OUT</sub> = 30% +V <sub>OUT</sub> = 30%, -V <sub>OUT</sub> = 70%	-	370	500	-	400	500	mV
EFFICIENCY	Full Load <sup>5</sup>	73	78	-	78	84	-	%
LOAD FAULT POWER DISSIPATION	Overload <sup>4</sup>	-	-	8	-	-	8	W
	Short Circuit	-	-	8	-	-	8	W
CAPACITIVE LOAD <sup>4</sup>	Either Output	-	-	500	-	-	500	μF
SWITCHING FREQUENCY		350	450	500	350	450	500	kHz
ISOLATION	500 V <sub>DC</sub> , T <sub>CASE</sub> = 25°C	100	-	-	100	-	-	MΩ
MTBF (MIL-HDBK-217F)	AIF @ T <sub>C</sub> = 55°C	-	427	-	-	427	-	kHrs

See notes next page.

## SPECIFICATIONS (T<sub>CASE</sub> = -55°C to +125°C, V<sub>IN</sub> = +28V ± 5%, Full Load<sup>5</sup>, Unless Otherwise Specified)

### ABSOLUTE MAXIMUM RATINGS

Input Voltage (Continuous)	50 V <sub>DC</sub>	Junction Temperature Rise to Case	+12°C
Input Voltage (Transient, 1 second)	80 Volts	Storage Temperature	-65°C to +150°C
Output Power <sup>1</sup>	20 Watts	Lead Solder Temperature (10 seconds)	270°C
Power Dissipation (Full Load, T <sub>CASE</sub> = +125°C)	6 Watts	Weight (Maximum) (Un-Flanged / Flanged)	(24 / 28) Grams
ESD Rating Per MIL-PRF-38534	2		

Parameter	Conditions	DVHF2805D			DVHF2812D			Units	
		Min	Typ	Max	Min	Typ	Max		
<b>DYNAMIC</b>									
Load Step Output Transient	±V <sub>OUT</sub>	Half Load to Full Load	-	200	400	-	220	400	mV <sub>PK</sub>
Load Step Recovery <sup>2</sup>			-	300	500	-	200	500	μSec
Line Step Output Transient <sup>4</sup>	±V <sub>OUT</sub>	V <sub>IN</sub> = 16V to 40V	-	400	800	-	500	900	mV <sub>PK</sub>
Line Step Recovery <sup>2, 4</sup>			-	300	700	-	300	500	μSec
Turn On Delay	±V <sub>OUT</sub>	V <sub>IN</sub> = 0V to 28V	-	10	20	-	10	20	mSec
Turn On Overshoot			-	0	25	-	0	50	mV <sub>PK</sub>

- Notes:
1. Dependant on output voltage.
  2. Time for output voltage to settle within 1% of its nominal value.
  3. Derate linearly to 0 at 135°C.
  4. Verified by qualification testing.
  5. Half load at +V<sub>OUT</sub> and half load at -V<sub>OUT</sub>.
  6. Up to 70% of the total power or current can be drawn from any one of the two outputs.
  7. 5% Load to Full Load at -55°C.

## SPECIFICATIONS (T<sub>CASE</sub> = -55°C to +125°C, V<sub>IN</sub> = +28V ± 5%, Full Load<sup>5</sup>, Unless Otherwise Specified)

### ABSOLUTE MAXIMUM RATINGS

Input Voltage (Continuous)	50 V <sub>DC</sub>	Junction Temperature Rise to Case	+12°C
Input Voltage (Transient, 1 second)	80 Volts	Storage Temperature	-65°C to +150°C
Output Power <sup>1</sup>	20 Watts	Lead Solder Temperature (10 seconds)	270°C
Power Dissipation (Full Load, T <sub>CASE</sub> = +125°C)	6 Watts	Weight (Maximum) (Un-Flanged / Flanged)	(24 / 28) Grams
ESD Rating per MIL-PRF-38534	2		

Parameter	Conditions	DVHF2815D			Units
		Min	Typ	Max	
<b>STATIC</b>					
INPUT Voltage <sup>4</sup>	Continuous	15	28	50	V
	Transient, 1 sec	-	-	80	V
Current	Inhibited	-	4	6	mA
	No Load	-	50	65	mA
Ripple Current	Full Load <sup>5</sup> , 20Hz to 10MHz	-	40	90	mA <sub>p-p</sub>
Inhibit Pin Input <sup>4</sup>		0	-	1.5	V
Inhibit Pin Open Circuit Voltage <sup>4</sup>		9.0	11.0	13.0	V
UVLO Turn On		12.0	-	14.8	V
UVLO Turn Off <sup>4</sup>		11.0	-	14.5	V
OUTPUT Voltage <sup>5</sup>	+V <sub>OUT</sub> T <sub>CASE</sub> = 25°C	14.85	15.0	15.15	V
	+V <sub>OUT</sub> T <sub>CASE</sub> = -55°C to +125°C	14.775	15.0	15.225	V
	-V <sub>OUT</sub> T <sub>CASE</sub> = 25°C	14.80	15.0	15.20	V
	-V <sub>OUT</sub> T <sub>CASE</sub> = -55°C to +125°C	14.40	15.0	15.60	V
Power <sup>3,6</sup>	Total	-	-	20	W
	±V <sub>OUT</sub> Either Output	-	-	14	W
Current <sup>3,6</sup>	±V <sub>OUT</sub> Either Output	-	-	0.93	A
Ripple Voltage	±V <sub>OUT</sub> Full Load <sup>5</sup> , 20Hz to 10MHz	-	30	60	mV <sub>p-p</sub>
Line Regulation	+V <sub>OUT</sub> V <sub>IN</sub> = 16V to 40V	-	2	20	mV
	-V <sub>OUT</sub> V <sub>IN</sub> = 16V to 40V	-	40	200	mV
Load Regulation	+V <sub>OUT</sub> No Load to Full Load <sup>5</sup>	-	5	50	mV
	-V <sub>OUT</sub> No Load to Full Load <sup>5,7</sup>	-	25	200	mV
Cross Regulation	-V <sub>OUT</sub> +V <sub>OUT</sub> = 70%, -V <sub>OUT</sub> = 30% +V <sub>OUT</sub> = 30%, -V <sub>OUT</sub> = 70%	-	400	500	mV
EFFICIENCY	Full Load <sup>5</sup>	79	85	-	%
LOAD FAULT POWER DISSIPATION	Overload <sup>4</sup>	-	-	8	W
	Short Circuit	-	-	8	W
CAPACITIVE LOAD <sup>4</sup>	Either Output	-	-	500	μF
SWITCHING FREQUENCY		350	450	500	kHz
ISOLATION	500 V <sub>DC</sub> , T <sub>CASE</sub> = 25°C	100	-	-	MΩ
MTBF (MIL-HDBK-217F)	AIF @ T <sub>C</sub> = 55°C	-	427	-	kHrs

See notes next page.

## SPECIFICATIONS (T<sub>CASE</sub> = -55°C to +125°C, V<sub>IN</sub> = +28V ± 5%, Full Load<sup>5</sup>, Unless Otherwise Specified)

### ABSOLUTE MAXIMUM RATINGS

Input Voltage (Continuous)	50 V <sub>DC</sub>	Junction Temperature Rise to Case	+12°C
Input Voltage (Transient, 1 second)	80 Volts	Storage Temperature	-65°C to +150°C
Output Power <sup>1</sup>	20 Watts	Lead Solder Temperature (10 seconds)	270°C
Power Dissipation (Full Load, T <sub>CASE</sub> = +125°C)	6 Watts	Weight (Maximum) (Un-Flanged / Flanged)	(24 / 28) Grams
ESD Rating per MIL-PRF-38534	2		

Parameter	Conditions	DVHF2815D			Units	
		Min	Typ	Max		
<b>DYNAMIC</b>						
Load Step Output Transient	±V <sub>OUT</sub>	Half Load to Full Load	-	200	400	mV <sub>PK</sub>
Load Step Recovery <sup>2</sup>			-	100	500	µSec
Line Step Output Transient <sup>4</sup>	±V <sub>OUT</sub>	V <sub>IN</sub> = 16V to 40V	-	500	900	mV <sub>PK</sub>
Line Step Recovery <sup>2, 4</sup>			-	300	500	µSec
Turn On Delay	±V <sub>OUT</sub>	V <sub>IN</sub> = 0V to 28V	-	10	20	mSec
Turn On Overshoot			-	0	50	mV <sub>PK</sub>

- Notes:
1. Dependant on output voltage.
  2. Time for output voltage to settle within 1% of its nominal value.
  3. Derate linearly to 0 at 135°C.
  4. Verified by qualification testing.
  5. Half load at +V<sub>OUT</sub> and half load at -V<sub>OUT</sub>.
  6. Up to 70% of the total power or current can be drawn from any one of the two outputs.
  7. 5% Load to Full Load at -55°C.

**BLOCK DIAGRAM**

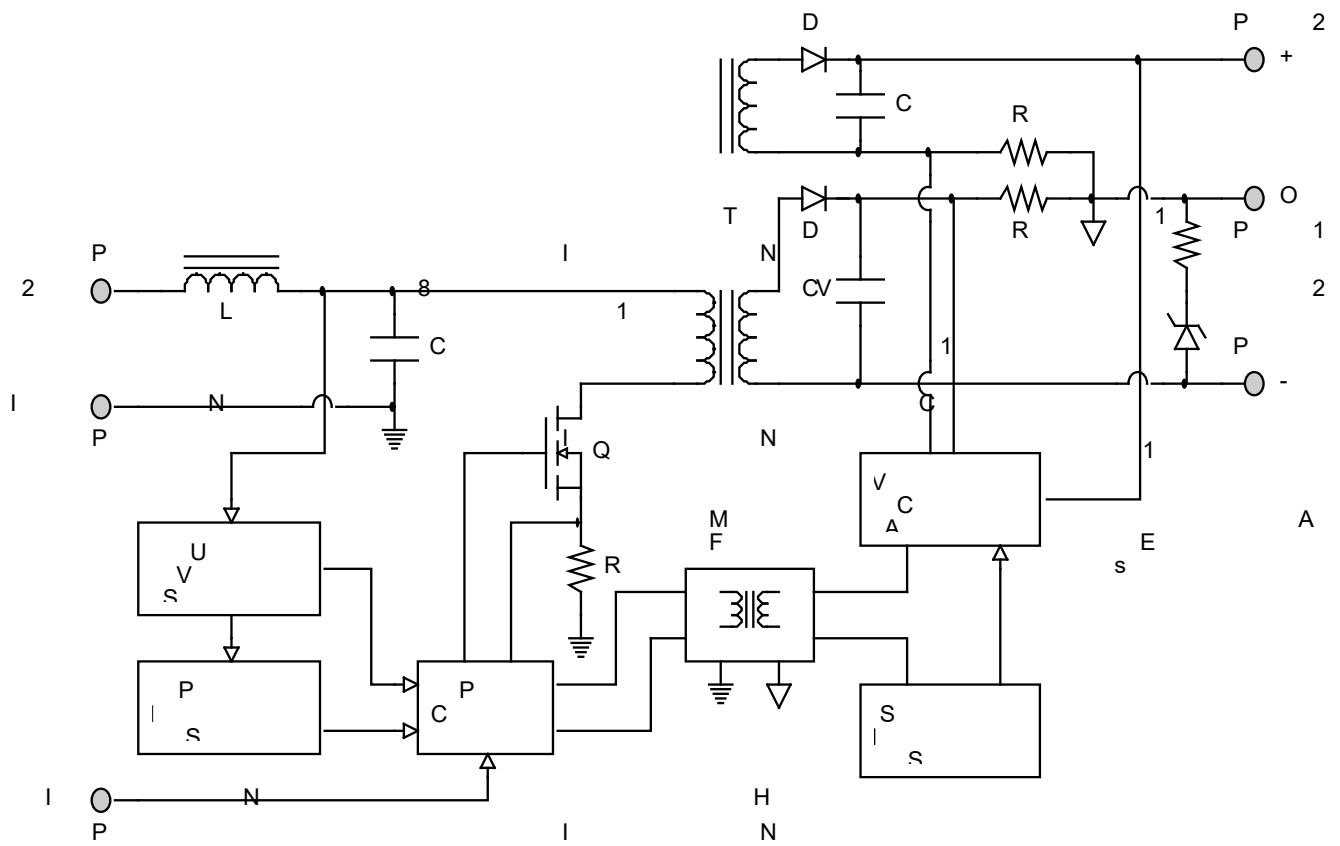


Figure 2

**CONNECTION DIAGRAM**

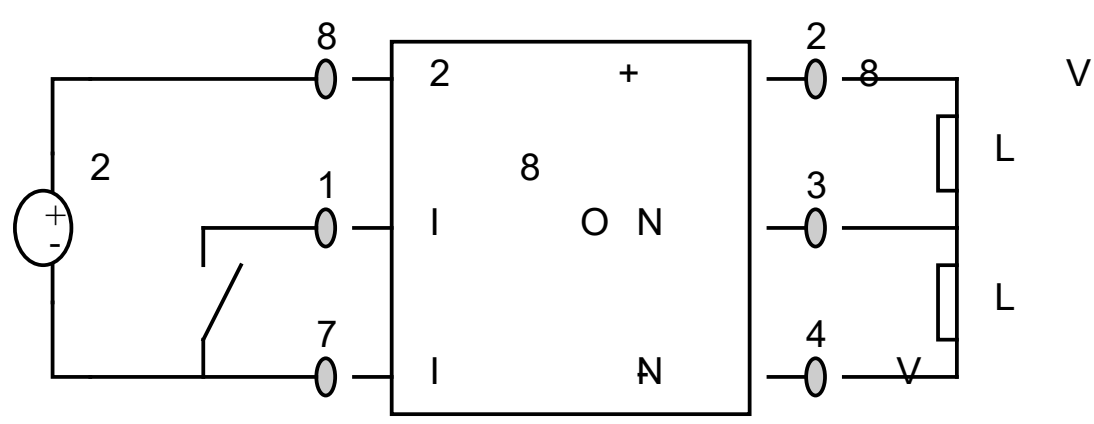
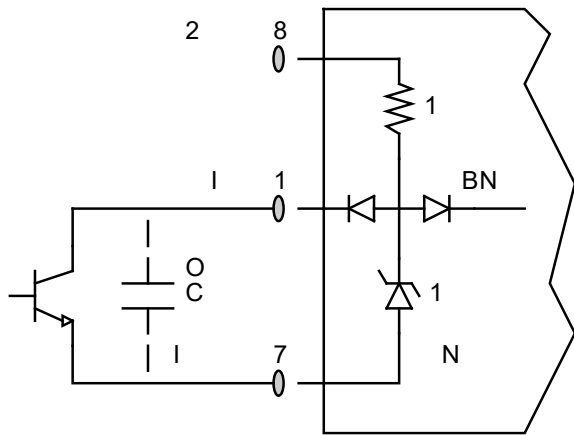
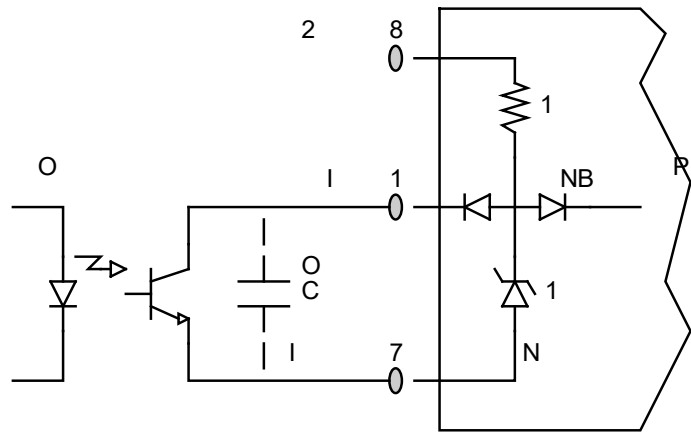


Figure 3

**INHIBIT DRIVE CONNECTION DIAGRAMS**

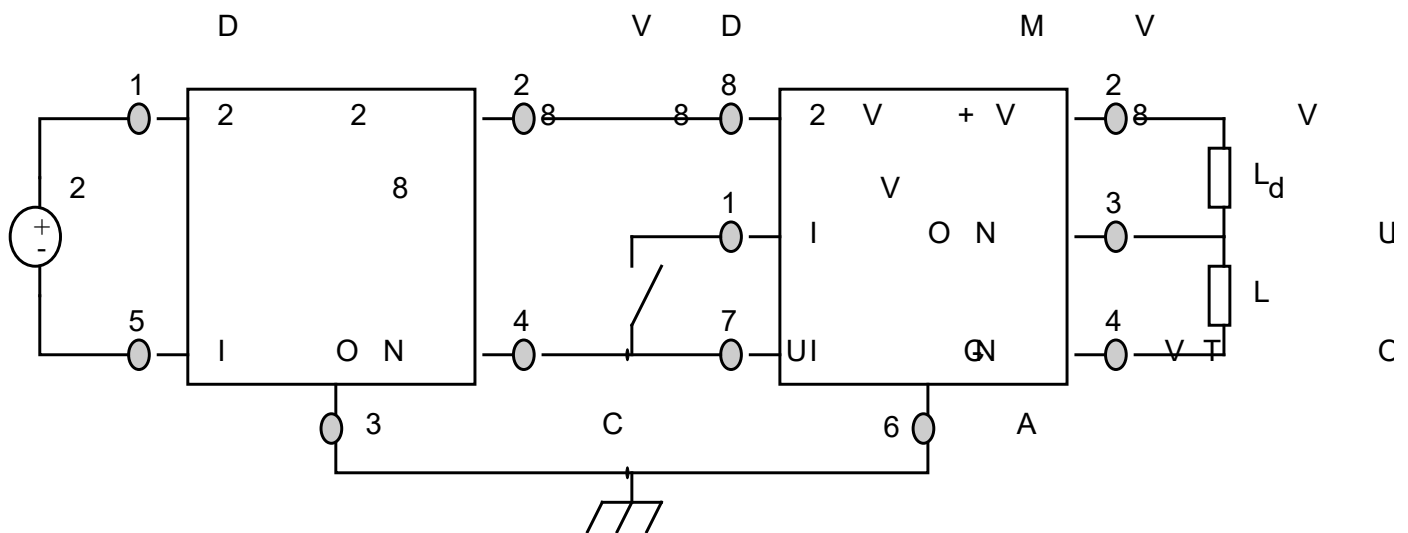


**Figure 4** – Internal Inhibit Circuit and Recommended Drive  
(Shown with optional capacitor for turn-on delay)



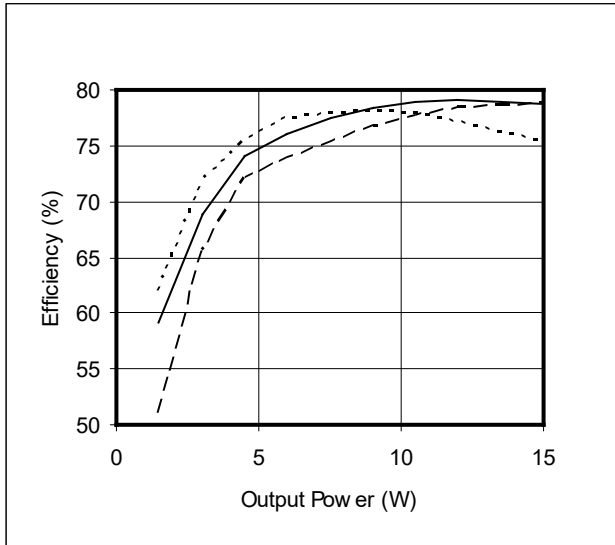
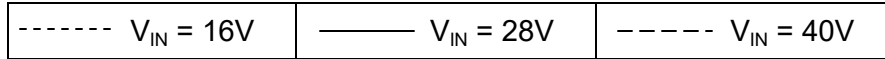
**Figure 5** – Isolated Inhibit Drive  
(Shown with optional capacitor for turn-on delay)

**EMI FILTER HOOKUP DIAGRAM**

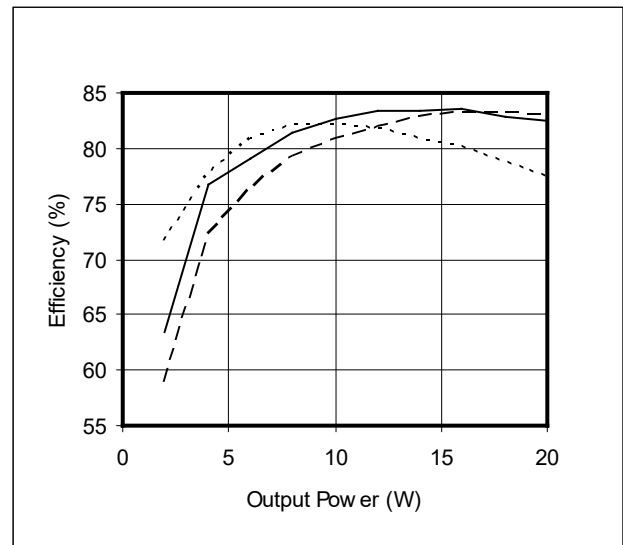


**Figure 6** – Converter with EMI Filter

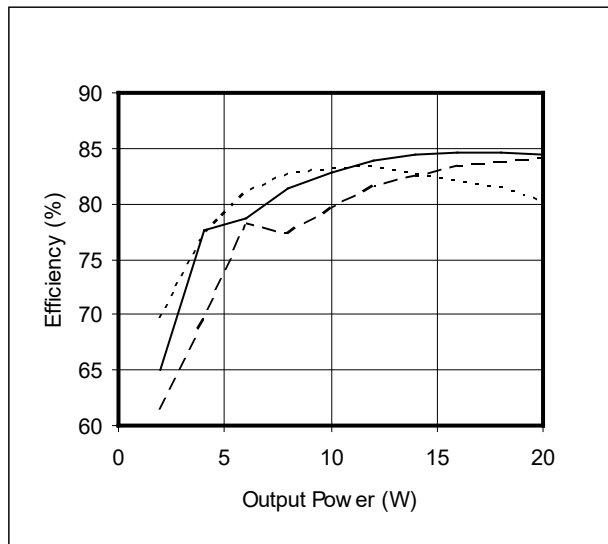
**EFFICIENCY PERFORMANCE CURVES** ( $T_{CASE} = 25^{\circ}C$ , Full Load, Unless Otherwise Specified)



**Figure 7 – DVHF2805D**  
Efficiency (%) vs. Output Power (W)



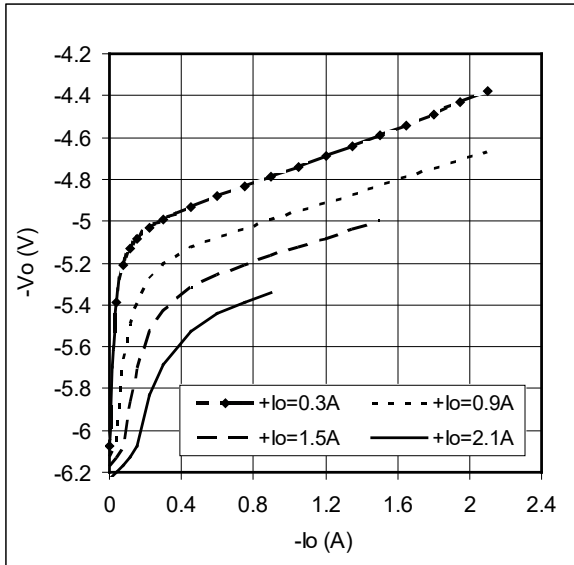
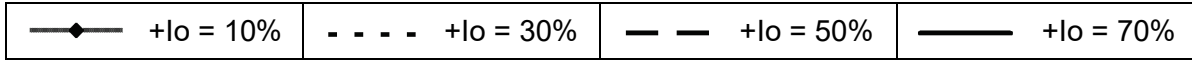
**Figure 8 – DVHF2812D**  
Efficiency (%) vs. Output Power (W)



**Figure 9 – DVHF2815D**  
Efficiency (%) vs. Output Power (W)

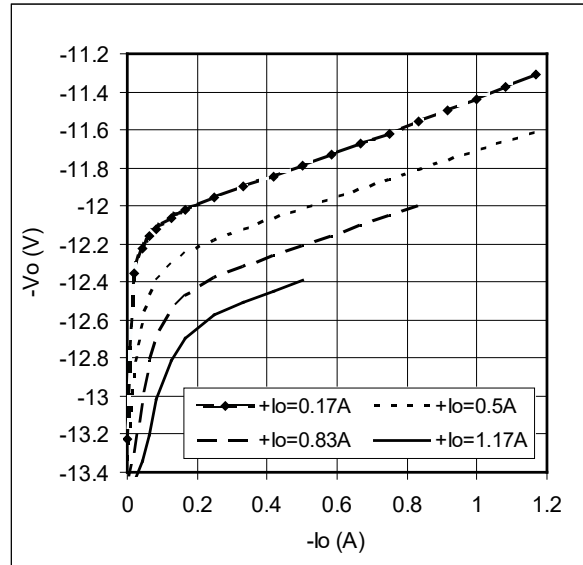


**CROSS REGULATION CURVES** ( $T_{CASE} = 25^{\circ}C$ , Full Load, Unless Otherwise Specified)



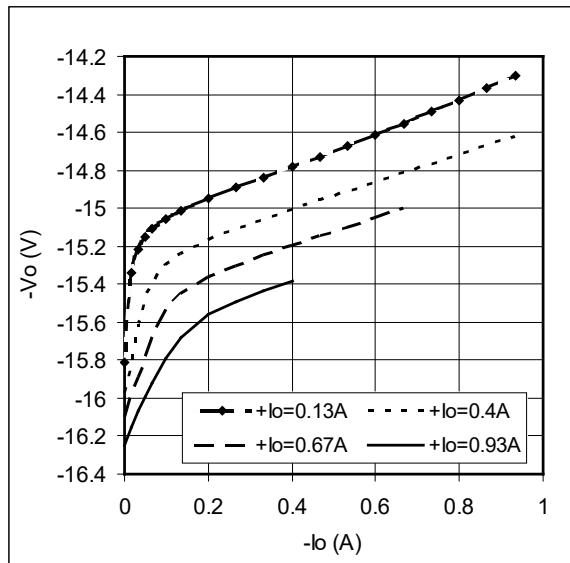
**Figure 10 – DVHF2805D**

-Vout (V) vs. -Iout (A)



**Figure 11 – DVHF2812D**

-Vout (V) vs. -Iout (A)

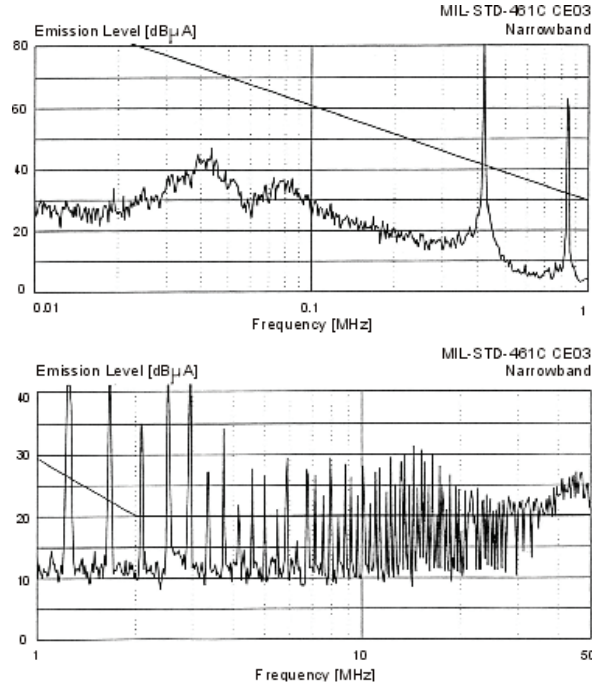


**Figure 12 – DVHF2815D**

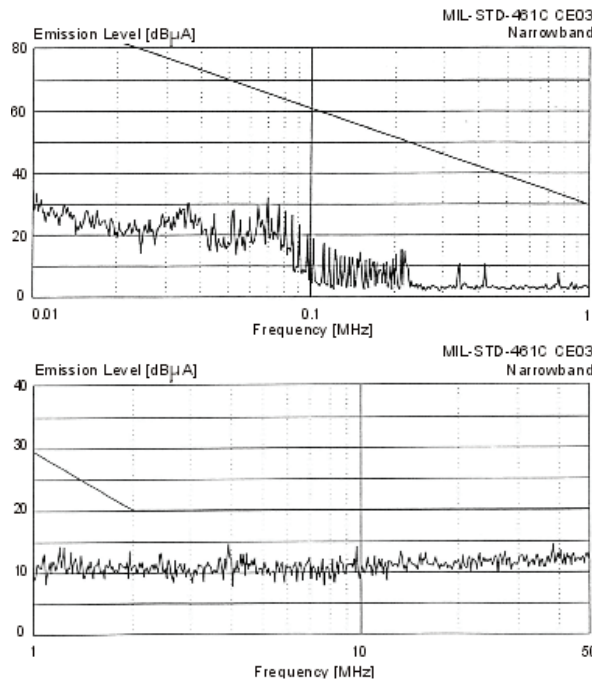
-Vout (V) vs. -Iout (A)

**EMI PERFORMANCE CURVES**

( $T_{CASE} = 25^{\circ}C$ ,  $V_{IN} = +28V \pm 5\%$ , Full Load, Unless Otherwise Specified)

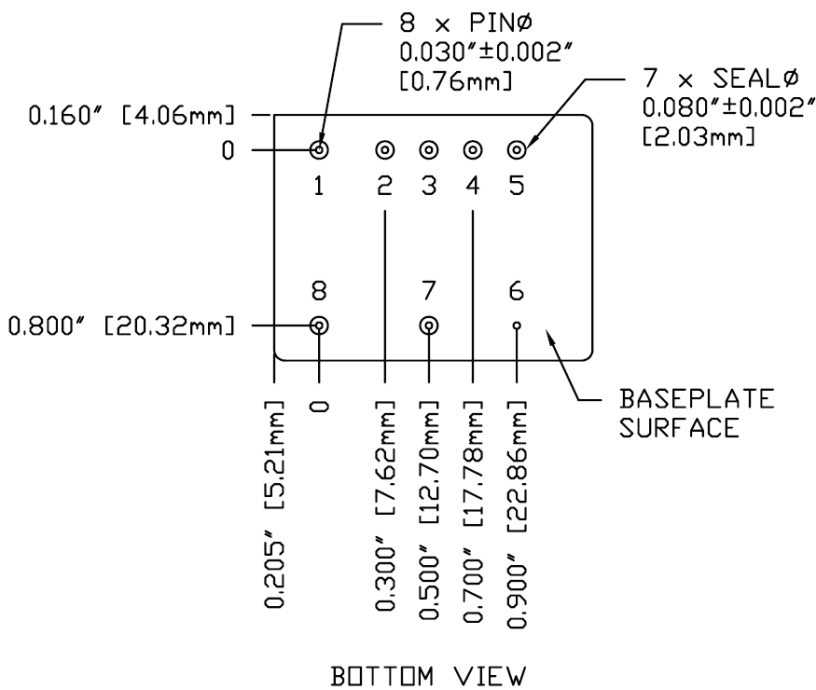
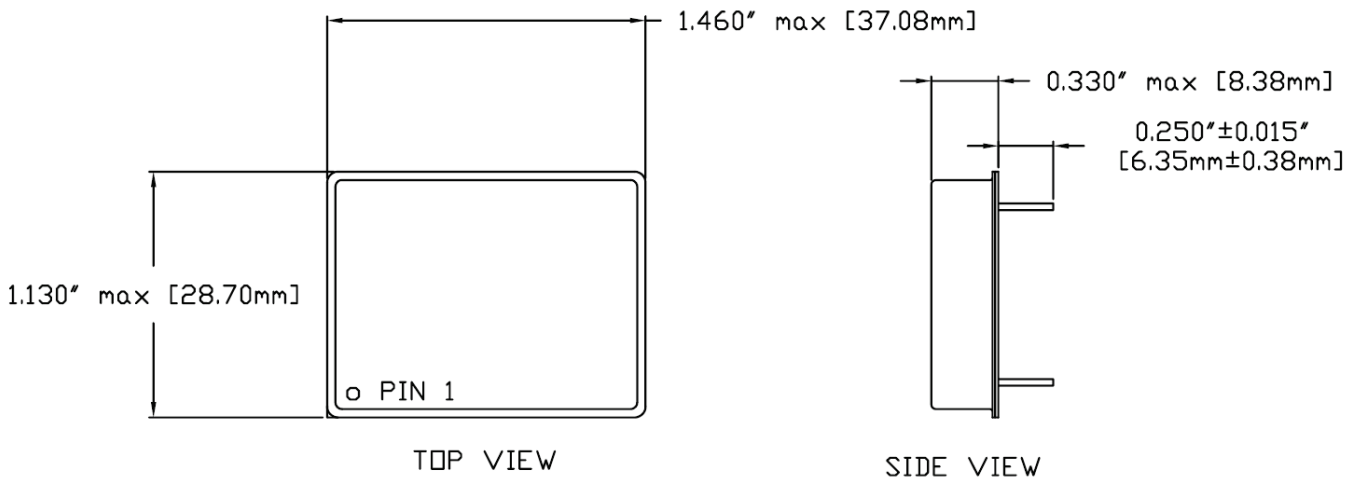


**Figure 13 – DVHF2800D without EMI Filter**



**Figure 14 – DVHF2800D with EMI Filter**

**PACKAGE SPECIFICATIONS (NON-FLANGED)**

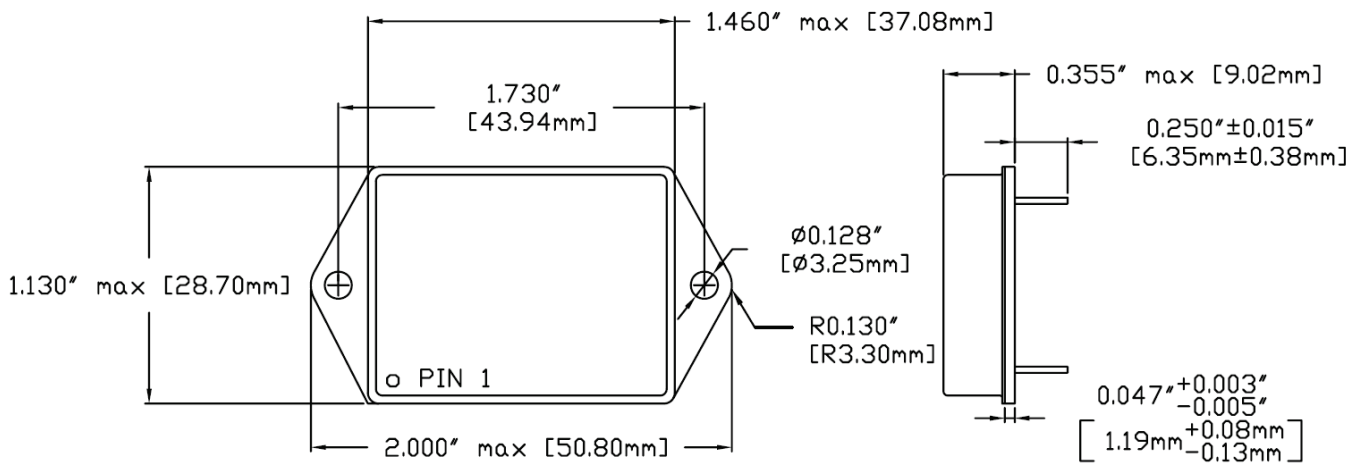


- NOTES:
1. DIMENSIONAL LIMITS ARE  $\pm 0.005"$  UNLESS OTHERWISE STATED.
  2. CASE TEMPERATURE IS MEASURED ON THE CENTER OF THE BASEPLATE.
  3. MATERIALS:  
CASE: STEEL, GOLD OVER NICKEL PLATED.  
COVER: STEEL, NICKEL PLATED.  
PINS: ALLOY 52, GOLD OVER NICKEL PLATED.  
PIN SEALS: GLASS

Pin	Function	Pin	Function
1	INHIBIT	5	N/C
2	+V OUT	6	CASE
3	OUT COM	7	IN COM
4	-V OUT	8	28V IN

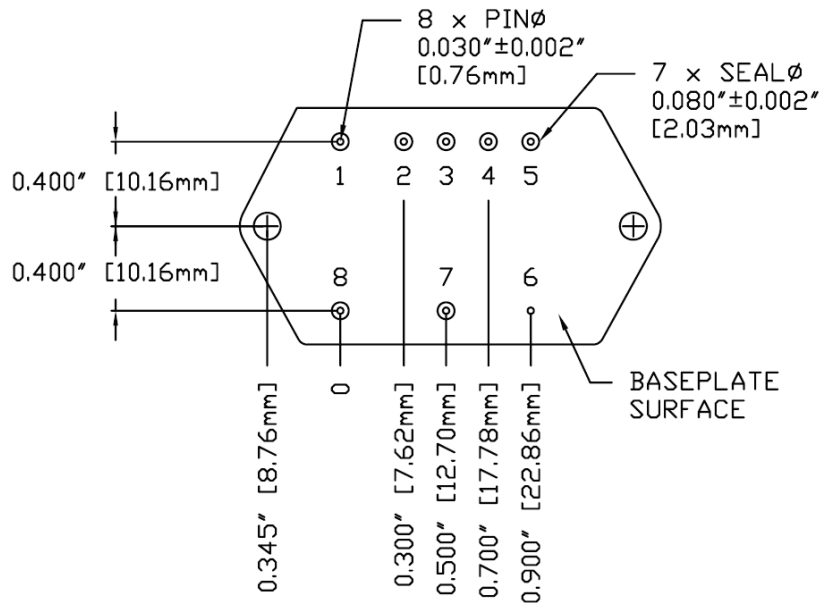
**Figure 15** – Non-Flanged Package and Pinout

**PACKAGE SPECIFICATIONS (FLANGED)**



TOP VIEW

SIDE VIEW



BOTTOM VIEW

- NOTES:
1. DIMENSIONAL LIMITS ARE ±0.005" UNLESS OTHERWISE STATED.
  2. CASE TEMPERATURE IS MEASURED ON THE CENTER OF THE BASEPLATE.
  3. MOUNTING HOLES ARE NOT THREADED. RECOMMENDED FASTENER IS #4-40 SCREW.
  4. MATERIALS:  
CASE: STEEL, GOLD OVER NICKEL PLATED.  
COVER: STEEL, NICKEL PLATED.  
PINS: ALLOY 52, GOLD OVER NICKEL PLATED.  
PIN SEALS: GLASS

Pin	Function	Pin	Function
1	INHIBIT	5	N/C
2	+V OUT	6	CASE
3	OUT COM	7	IN COM
4	-V OUT	8	28V IN

**Figure 16** – Flanged Package and Pinout

## PACKAGE PIN DESCRIPTION

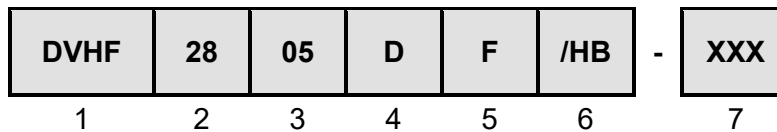
Pin	Function	Description
1	INHIBIT	Logic Low = Disabled Output. Connecting the inhibit pin to input common (PIN 7) causes converter shutdown. Logic High = Enabled Output. Unconnected or open collector TTL.
2	+V OUT	Positive Output Voltage Connection
3	OUT COM	Output Common Connection
4	-V OUT	Negative Output Voltage Connection
5	N/C	No Connection
6	CASE	Case Connection
7	IN COM	Input Common Connection
8	28V IN	Positive Input Voltage Connection

## ENVIRONMENTAL SCREENING (100% Tested Per MIL-STD-883 as referenced to MIL-PRF-38534)

Screening	MIL-STD-883	Standard (No Suffix)	Extended /ES	HB /HB	Class H /H	Class K /K
Non-Destructive Bond Pull	Method 2023	•	•	•	•	•
Internal Visual	Method 2017, 2032 Internal Procedure	•	•	•	•	•
Temperature Cycling	Method 1010, Condition C Method 1010, -55°C to 125°C		•	•	•	•
Constant Acceleration	Method 2001, 3000g, Y1 Direction Method 2001, 500g, Y1 Direction		•	•	•	•
PIND	Method 2020, Condition A <sup>2</sup>					•
Pre Burn-In Electrical	100% at 25°C					•
Burn-In	Method 1015, 320 hours at +125°C Method 1015, 160 hours at +125°C 96 hours at +125°C 24 hours at +125°C	•	•	•	•	•
Final Electrical	MIL-PRF-38534, Group A <sup>1</sup> 100% at 25°C	•	•	•	•	•
Hermeticity	Method 1014, Fine Leak, Condition A Method 1014, Gross Leak, Condition C Dip (1 x 10 <sup>-3</sup> )	•	•	•	•	•
Radiography	Method 2012 <sup>3</sup>					•
External Visual	Method 2009	•	•	•	•	•

- Notes:
1. 100% R&R testing at -55°C, +25°C, and +125°C with all test data included in product shipment.
  2. PIND test Certificate of Compliance included in product shipment.
  3. Radiographic test Certificate of Compliance and film(s) included in product shipment.

## ORDERING INFORMATION



(1) Product Series	(2) Nominal Input Voltage		(3) Output Voltage		(4) Number of Outputs	
<b>DVHF</b>	<b>28</b>	28 Volts	<b>05</b> <b>12</b> <b>15</b>	± 5 Volts ± 12 Volts ± 15 Volts	<b>D</b>	Dual

(5) Package Option		(6) Screening Code <sup>1,2</sup>		(7) Additional Screening Code
<b>None</b> <b>F</b>	Non-Flanged Flanged	<b>None</b> <b>/ES</b> <b>/HB</b> <b>/H</b> <b>/K</b>	Standard Extended HB Class H Class K	Contact Sales

- Notes:
1. Contact the VPT Inc. Sales Department for availability of Class H (/H) or Class K (/K) qualified products.
  2. VPT Inc. reserves the right to ship higher screened or SMD products to meet lower screened orders at our sole discretion unless specifically forbidden by customer contract.

Please contact your sales representative or the VPT Inc. Sales Department for more information concerning additional environmental screening and testing, different input voltage, output voltage, power requirement, source inspection, and/or special element evaluation for space or other higher quality applications.

## SMD (STANDARD MICROCIRCUIT DRAWING) NUMBERS

Standard Microcircuit Drawing (SMD)	DVHF2800D Series Similar Part Number
5962-0324401HXC 5962-0324401HXA 5962-0324401HYC 5962-0324401HYA 5962-0324401KXC 5962-0324401KXA 5962-0324401KYC 5962-0324401KYA	DVHF2805D/H DVHF2805D/H-E DVHF2805DF/H DVHF2805DF/H-E DVHF2805D/K DVHF2805D/K-E DVHF2805DF/K DVHF2805DF/K-E
5962-0324402HXC 5962-0324402HXA 5962-0324402HYC 5962-0324402HYA 5962-0324402KXC 5962-0324402KXA 5962-0324402KYC 5962-0324402KYA	DVHF2812D/H DVHF2812D/H-E DVHF2812DF/H DVHF2812DF/H-E DVHF2812D/K DVHF2812D/K-E DVHF2812DF/K DVHF2812DF/K-E
5962-0324403HXC 5962-0324403HXA 5962-0324403HYC 5962-0324403HYA 5962-0324403KXC 5962-0324403KXA 5962-0324403KYC 5962-0324403KYA	DVHF2815D/H DVHF2815D/H-E DVHF2815DF/H DVHF2815DF/H-E DVHF2815D/K DVHF2815D/K-E DVHF2815DF/K DVHF2815DF/K-E

Do not use the DVHF2800D Series similar part number for SMD product acquisition. It is listed for reference only. For exact specifications for the SMD product, refer to the SMD drawing. SMDs can be downloaded from the DLA Land and Maritime (Previously known as DSCC) website at <https://landandmaritimeapps.dla.mil/programs/defaultapps.asp>. The SMD number listed above is for standard gold-plated lead finish and "P" RHA (Radiation Hardness Assurance) level. Please reference the SMD for other screening levels, lead finishes, and radiation levels. All SMD products are marked with a "Q" on the cover as specified by the QML certification mark requirement of MIL-PRF-38534.



**CONTACT INFORMATION**

To request a quotation or place orders please contact your sales representative or the VPT Inc. Sales Department at:

**Phone:** (425) 353-3010  
**Fax:** (425) 353-4030  
**E-mail:** [vptsales@vpt-inc.com](mailto:vptsales@vpt-inc.com)

All information contained in this datasheet is believed to be accurate, however, no responsibility is assumed for possible errors or omissions. The products or specifications contained herein are subject to change without notice.