

DVP-NS71HP/NS75H/NS76H

RMT-D175A/RMT-D175P

SERVICE MANUAL

US Model
DVP-NS71HP/NS75H
Canadian Model
DVP-NS75H

AEP Model
Singapore Model
Korea Model
E Model
Russian Model
UK Model
DVP-NS76H



SPECIFICATIONS

System

Laser: Semiconductor laser
Signal format system: PAL/NTSC
DVP-NS76H: EXCEPT E32)
Signal format system: NTSC
(DVP-NS71HP/NS75H/NS76H:E32)

Audio characteristics

Frequency response: DVD VIDEO
(PCM 96 kHz): 2 Hz to 44 kHz
(±1.0 dB)/DVD VIDEO (PCM 48 kHz):
2 Hz to 22 kHz (±0.5 dB)/CD: 2 Hz to
20 kHz (±0.5 dB)
Signal-to-noise ratio (S/N ratio): 115 dB
(LINE OUT L/R (AUDIO) jacks only)
Harmonic distortion: 0.003%
Dynamic range: DVD VIDEO:
103 dB/CD: 99 dB
Wow and flutter: Less than detected value
(±0.001% W PEAK)

Outputs

(Jack name): Jack type/Output level/
Load impedance)
LINE OUT (AUDIO): Phono jack/
2 Vrms/ 10 kilohms
DIGITAL OUT (OPTICAL):
Optical output jack/-18 dBm
(wave length 660 nm)

DIGITAL OUT (COAXIAL): Phono jack/
0.5 Vp-p/75 ohms

HDMI OUT: Type A (19 pin)
LINE OUT (VIDEO): Phono jack/
1.0 Vp-p/75 ohms

S VIDEO OUT:
4-pin mini DIN/Y: 1.0 Vp-p,
C: 0.3 Vp-p (PAL),
0.286 Vp-p (NTSC)/75 ohms
(DVP-NS76H:EXCEPT E32)

S VIDEO OUT:
4-pin mini DIN/Y: 1.0 Vp-p,
C: 0.286 Vp-p/75 ohms
(DVP-NS71HP/NS75H/NS76H:E32)

COMPONENT VIDEO OUT:

(Y, Pb/Cb, Pr/Cr)
Phono jack/Y: 1.0 Vp-p,
Pb/Cb, Pr/Cr: 0.7 Vp-p/75 ohms
(DVP-NS76H:EXCEPT E32)

COMPONENT VIDEO OUT: (Y, Pb, Pr)

Phono jack/Y: 1.0 Vp-p/Pb,Pr:
interface^{*1} = 0.648 Vp-p, progressive or
interface^{*2} = 0.7 Vp-p/75 ohms

^{*1} BLACK LEVEL
(COMPONENT OUT) is ON

^{*2} BLACK LEVEL
(COMPONENT OUT) is OFF
(DVP-NS71HP/NS75H/NS76H:E32)

General

Power requirements:
220 – 240 V AC, 50/60 Hz
(DVP-NS76H: AEP,UK,RUS)
120 V AC, 60 Hz (DVP-NS71HP/NS75H)
110 – 240 V AC, 50/60 Hz
(DVP-NS76H:E,SP,KR)

Power consumption:
12W (DVP-NS76H:AEP,
UK,RUS/NS71HP/NS75H)
11W (DVP-NS76H:E,SP,KR)

Dimensions (approx.):
430 × 43 × 237 mm
(width/height/depth) incl. projecting parts

Mass (approx.): 1.92 kg
Operating temperature: 5°C to 35°C
Operating humidity: 25% to 80%

Supplied accessories

See page 1-3 (Service Manual Page).

Specifications and design are subject to
change without notice.



CD/DVD PLAYER

SONY®

SAFETY CHECK-OUT

After correcting the original service problem, perform the following safety checks before releasing the set to the customer:

1. Check the area of your repair for unsoldered or poorly-soldered connections. Check the entire board surface for solder splashes and bridges.
2. Check the interboard wiring to ensure that no wires are "pinched" or contact high-wattage resistors.
3. Look for unauthorized replacement parts, particularly transistors, that were installed during a previous repair. Point them out to the customer and recommend their replacement.
4. Look for parts which, though functioning, show obvious signs of deterioration. Point them out to the customer and recommend their replacement.
5. Check the line cord for cracks and abrasion. Recommend the replacement of any such line cord to the customer.
6. Check the B+ voltage to see it is at the values specified.
7. Check the antenna terminals, metal trim, "metallized" knobs, screws, and all other exposed metal parts for AC leakage. Check leakage as described below.

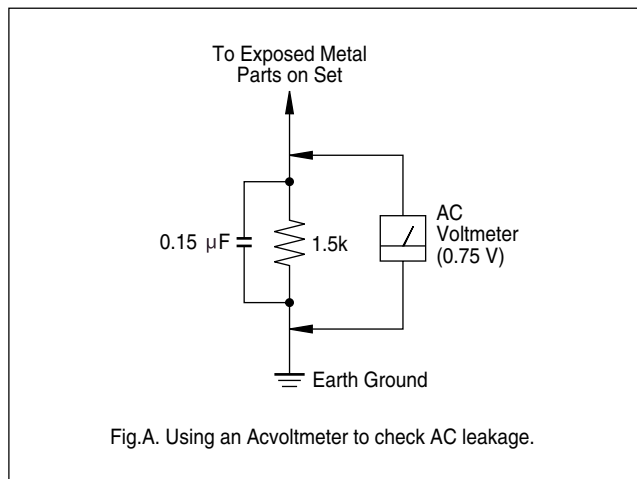

WARNING!!

WHEN SERVICING, DO NOT APPROACH THE LASER EXIT WITH THE EYE TOO CLOSELY. IN CASE IT IS NECESSARY TO CONFIRM LASER BEAM EMISSION, BE SURE TO OBSERVE FROM A DISTANCE OF MORE THAN 25 cm FROM THE SURFACE OF THE OBJECTIVE LENS ON THE OPTICAL PICK-UP BLOCK.

CAUTION:

The use of optical instrument with this product will increase eye hazard.

CAUTION

Use of controls or adjustments or performance of procedures other than those specified herein may result in hazardous radiation exposure.

SAFETY-RELATED COMPONENT WARNING!!

COMPONENTS IDENTIFIED BY MARK \triangle OR DOTTED LINE WITH MARK \triangle ON THE SCHEMATIC DIAGRAMS AND IN THE PARTS LIST ARE CRITICAL TO SAFE OPERATION. REPLACE THESE COMPONENTS WITH SONY PARTS WHOSE PART NUMBERS APPEAR AS SHOWN IN THIS MANUAL OR IN SUPPLEMENTS PUBLISHED BY SONY.

LEAKAGE TEST

The AC leakage from any exposed metal part to earth ground and from all exposed metal parts to any exposed metal part having a return to chassis, must not exceed 0.5mA (500 microampers). Leakage current can be measured by any one of three methods.

1. A commercial leakage tester, such as the Simpson 229 or RCA TW-540A. Follow the manufacturers' instructions to use these instruments.
2. A battery-operated AC milliammeter. The Data Precision 245 digital multimeter is suitable for this job.
3. Measuring the voltage drop across a resistor by means of a VOM or battery-operated AC voltmeter. The "limit" indication is 0.75V, so analog meters must have an accurate low voltage scale. The Simpson 250 and Sanwa SH-63Trd are examples of a passive VOM that is suitable. Nearly all battery operated digital multimeters that have a 2V AC range are suitable. (See Fig. A)

Unleaded solder

Boards requiring use of unleaded solder are printed with the lead-free mark (LF) indicating the solder contains no lead.

(Caution: Some printed circuit boards may not come printed with the lead free mark due to their particular size.)



: LEAD FREE MARK

Unleaded solder has the following characteristics.

- Unleaded solder melts at a temperature about 40°C higher than ordinary solder.
Ordinary soldering irons can be used but the iron tip has to be applied to the solder joint for a slightly longer time.
Soldering irons using a temperature regulator should be set to about 350°C
Caution: The printed pattern (copper foil) may peel away if the heated tip is applied for too long, so be careful!
- Strong viscosity
Unleaded solder is more viscous (sticky, less prone to flow) than ordinary solder so use caution not to let solder bridges occur such as on IC pins, etc.
- Usable with ordinary solder
It is best to use only unleaded solder but unleaded solder may also be added to ordinary solder.

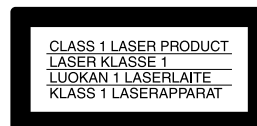

ATTENTION AU COMPOSANT AYANT RAPPORT À LA SÉCURITÉ!

LES COMPOSANTS IDENTIFIÉS PAR UNE MARQUE \triangle SUR LES DIAGRAMMES SCHÉMATIQUES ET LA LISTE DES PIÈCES SONT CRITIQUES POUR LA SÉCURITÉ DE FONCTIONNEMENT. NE REMPLACER CES COMPOSANTS QUE PAR DES PIÈCES SONY DONT LES NUMÉROS SONT DONNÉS DANS CE MANUEL OU DANS LES SUPPLÉMENTS PUBLIÉS PAR SONY.

TABLE OF CONTENTS

SERVICE NOTE

1. Disc Removal Procedure (at POWER OFF) 5

1. GENERAL

| | |
|--|------|
| WARNING | 1-1 |
| Notes About the Discs | 1-1 |
| Precautions | 1-1 |
| About This Manual | 1-1 |
| This Player Can Play the Following Discs | 1-1 |
| Index to Parts and Controls | 1-2 |
| Guide to the Control Menu Display (Magic Pad) | 1-3 |
| Hookups | 1-3 |
| Hooking Up the Player | 1-3 |
| Step 1: Unpacking | 1-3 |
| Step 2: Inserting Batteries into the Remote | 1-3 |
| Step 3: Connecting the Video Cords/HDMI Cords | 1-4 |
| Step 4: Connecting the Audio Cords | 1-5 |
| Step 5: Connecting the Mains Lead | 1-5 |
| Step 6: Quick Setup | 1-5 |
| Playing Discs | 1-6 |
| Playing Discs | 1-6 |
| Resuming Playback from the Point Where You Stopped the Disc (Multi-disc Resume) | 1-6 |
| Using the DVD's Menu | 1-6 |
| Selecting "ORIGINAL" or "PLAY LIST" on a DVD-RW/DVD-R | 1-6 |
| Playing VIDEO CD's With PBC Functions (PBC Playback) | 1-7 |
| Various Play Mode Functions (Programme Play, Shuffle Play, Repeat Play, A-B Repeat Play) | 1-7 |
| Searching for a Scene | 1-8 |
| Searching for a Particular Point on a Disc (Search, Scan, Slow-motion Play, Freeze Frame) | 1-8 |
| Searching for a Title/Chapter/Track/Scene, etc. | 1-8 |
| Searching by Scene (PICTURE NAVIGATION) | 1-9 |
| Viewing Information About the Disc | 1-9 |
| Checking the Playing Time and Remaining Time | 1-9 |
| Sound Adjustments | 1-10 |
| Changing the Sound | 1-10 |
| TV Virtual Surround Settings (TVS) | 1-10 |
| Enjoying Movies | 1-11 |
| Changing the Angles | 1-11 |
| Displaying the Subtitles | 1-11 |
| Adjusting the Playback Picture (CUSTOM PICTURE MODE) | 1-11 |
| Sharpening the Picture (SHARPNESS) | 1-11 |
| Adjusting the Picture Quality (BNR, MNR) | 1-12 |
| Adjusting the Delay Between the Picture and Sound (AV SYNC) | 1-12 |
| Enjoying MP3 Audio and JPEG Images | 1-12 |
| About MP3 Audio Tracks and JPEG Image Files | 1-12 |
| Playing MP3 Audio Tracks and JPEG Image Files | 1-13 |
| Enjoying JPEG Images as a Slide Show | 1-13 |
| Enjoying DivX Videos | 1-14 |
| About DivX Video Files | 1-14 |
| Playing DivX Video Files | 1-14 |
| Using Various Additional Functions | 1-15 |
| Locking Discs (CUSTOM PARENTAL CONTROL, PARENTAL CONTROL) | 1-15 |
| Controlling Your TV with the Supplied Remote | 1-15 |
| Settings and Adjustments | 1-16 |
| Using the Setup Display | 1-16 |
| Setting the Display or Sound Track Language (LANGUAGE SETUP) | 1-16 |
| Settings for the Display (SCREEN SETUP) | 1-16 |
| Custom Settings (CUSTOM SETUP) | 1-16 |
| Settings for the Sound (AUDIO SETUP) | 1-16 |

| | |
|--|------|
| Additional Information | 1-18 |
| Troubleshooting | 1-18 |
| Self-diagnosis Function (When letters/ numbers appear in the display) | 1-18 |
| Glossary | 1-19 |
| Specifications | 1-19 |

2. DISASSEMBLY

| | |
|--|-----|
| 2-1. Upper Case | 2-1 |
| 2-2. Front Panel Assembly and SW-470 Board | 2-1 |
| 2-3. Loading Assembly | 2-2 |
| 2-4. Optical Pick-Up (Device, Optical KHM-313CAA/C2RP) | 2-3 |
| 2-5. Rear Panel, MV-49 Board/IF-146 Board and ER-41 Board | 2-4 |
| 2-6. Switching Regulator | 2-5 |
| 2-7. Internal Views | 2-6 |
| 2-8. Circuit Boards Location | 2-7 |

3. BLOCK DIAGRAMS

| | |
|--|------|
| 3-1. Overall Block Diagram | 3-1 |
| 3-2. Power Line (1) Block Diagram | 3-3 |
| 3-3. Power Line (2) Block Diagram | 3-5 |
| 3-4. System Control/Signal Processor Block Diagram | 3-7 |
| 3-5. RF/Servo Block Diagram | 3-9 |
| 3-6. Audio Block Diagram | 3-11 |
| 3-7. Video Block Diagram | 3-13 |
| 3-8. Interface Control Block Diagram | 3-15 |
| 3-9. HDMI Control Block Diagram | 3-17 |

4. PRINTED WIRING BOARDS AND SCHEMATIC DIAGRAMS

| | |
|--|------|
| 4-1. Frame Schematic Diagram | 4-1 |
| 4-2. Printed Wiring Boards and Schematic Diagrams | 4-3 |
| • Waveforms | |
| ER-41 Board | 4-4 |
| MV-49 Board | 4-4 |
| • ER-41 Printed Wiring Board | 4-5 |
| • ER-41 (Scart) Schematic Diagram | 4-7 |
| • IF-146 Printed Wiring Board | 4-9 |
| • IF-146 (Interface) Schematic Diagram | 4-11 |
| • MS-203 Printed Wiring Board | 4-13 |
| • MS-203 (Loading Motor) Schematic Diagram | 4-13 |
| • MV-49 Printed Wiring Board | 4-15 |
| • MV-49 (CPU, Servo-DSP, AVDEC) Schematic Diagram | 4-17 |
| • MV-49 (Drive) Schematic Diagram | 4-19 |
| • MV-49 (Video) Schematic Diagram | 4-21 |
| • MV-49 (Audio (2ch)) Schematic Diagram | 4-23 |
| • MV-49 (Audio (8ch)) Schematic Diagram | 4-25 |
| • MV-49 (Power Supply) Schematic Diagram | 4-27 |
| • MV-49 (HDMI) Schematic Diagram | 4-29 |
| • SW-470 Printed Wiring Board | 4-31 |
| • SW-470 (Switch) Schematic Diagram | 4-31 |
| • Power Block (SRV1838UC) Printed Wiring Board | 4-33 |
| • Power Block (SRV1838UC) Schematic Diagram | 4-35 |
| • Power Block (SRV1839WW) Printed Wiring Board | 4-37 |
| • Power Block (SRV1839WW) Schematic Diagram | 4-39 |

5. IC PIN FUNCTION DESCRIPTION

| | |
|---|-----|
| 5-1. System Control Pin Function (MV-49 Board IC101) | 5-1 |
|---|-----|

6. TEST MODE

6-1. Executing IOP Measurement 6-1
6-2. Emergency History Check 6-1
6-3. Initializing Setup Data 6-2
6-4. Version Information 6-3
6-5. If Con Self Diagnostic Function 6-3

7. ELECTRICAL ADJUSTMENT

7-1. Power Supply Output Voltage Check 7-1
7-2. Adjustment of Video System 7-2

8. REPAIR PARTS LIST

8-1. Exploded Views 8-1
8-1-1. Main Section 8-1
8-1-2. Mechanism Deck Assembly 8-3
8-2. Electrical Parts List 8-4

SERVICE NOTE

1. DISC REMOVAL PROCEDURE (at POWER OFF)

- 1) Open dust cover to access to a hole insert a tapering driver into the aperture of the unit bottom, and move the lever of chuck cam in the direction of the arrow A. (See Fig. 1)
- 2) Draw out the tray in the direction of the arrow B, and remove a disc. (See Fig. 1)
- 3) After removing the disc, push in the direction of arrow C until the tray fully in.
- 4) Move the lever of chuck cam in the direction of arrow D.

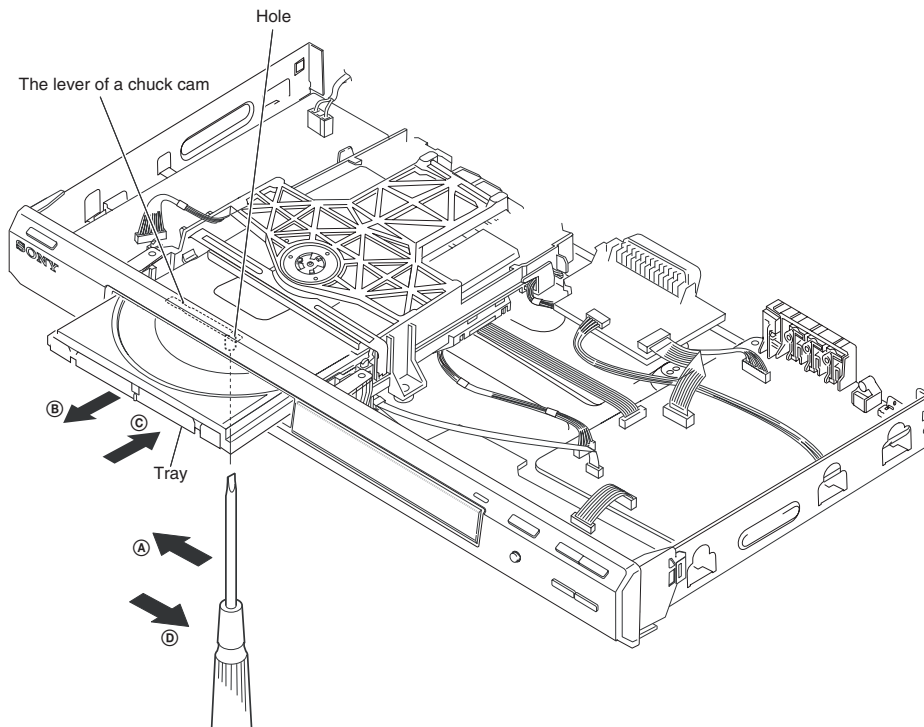

Fig. 1.

SECTION 1 GENERAL

This section is extracted from instruction manual. 2-666-956-12

WARNING

To reduce the risk of fire or electric shock, do not expose this apparatus to rain or moisture.
To avoid electrical shock, do not open the cabinet. Refer servicing to qualified personnel only.
The mains lead must only be changed at a qualified service shop.



Disposal of Old Electrical & Electronic Equipment (Applicable in the European Union and other European countries with separate collection systems)

This symbol on the product or on its packaging indicates that this product shall not be treated as household waste. Instead it shall be handed over to the applicable collection point for the recycling of electrical and electronic equipment. By ensuring this product is disposed of correctly, you will help prevent potential negative consequences for the environment and human health, which could otherwise be caused by inappropriate waste handling of this product. The recycling of materials will help to conserve natural resources. For more detailed information about recycling of this product, please contact your local Civic Office, your household waste disposal service or the shop where you purchased the product.

This appliance is classified as a CLASS 1 LASER product. The CLASS 1 LASER PRODUCT MARKING is located on the rear exterior.

CAUTION

The use of optical instruments with this product will increase eye hazard. As the laser beam used in this CD/DVD player is harmful to eyes, do not attempt to disassemble the cabinet. Refer servicing to qualified personnel only.

Notice for customers in the United Kingdom and Republic of Ireland

A moulded plug complying with BS1363 is fitted to this equipment for your safety and convenience. Should the fuse in the plug supplied need to be replaced, a 5AMP fuse approved by ASTA or BSI to BS1362, (i.e., marked with ⊕ or ⊗ mark) must be used. If the plug supplied with this equipment has a detachable fuse cover, be sure to attach the fuse cover after you change the fuse. Never use the plug without the fuse cover. If you should lose the fuse cover, please contact your nearest Sony service station.

Precautions

Safety

- This unit operates on 220 – 240 V AC, 50/60 Hz. Check that the unit's operating voltage is identical with your local power supply.
- To prevent fire or shock hazard, do not place objects filled with liquids, such as vases, on the apparatus.

Installing

- Do not install the unit in an inclined position. It is designed to be operated in a horizontal position only.
- Keep the unit and discs away from equipment with strong magnets, such as microwave ovens, or large loudspeakers.
- Do not place heavy objects on the unit.

Notes About the Discs

- To keep the disc clean, handle the disc by its edge. Do not touch the surface.



- Do not expose the disc to direct sunlight or heat sources such as hot air ducts, or leave it in a car parked in direct sunlight as the temperature may rise considerably inside the car.
- After playing, store the disc in its case.
- Clean the disc with a cleaning cloth. Wipe the disc from the centre out.



- Do not use solvents such as benzene, thinner, commercially available disc/lens cleaners, or anti-static spray intended for vinyl LPs.
- If you have printed the disc's label, dry the label before playing.

Precautions

On safety

Should any solid object or liquid fall into the cabinet, unplug the player and have it checked by qualified personnel before operating it any further.

On power sources

- The player is not disconnected from the AC power source (mains) as long as it is connected to the wall outlet, even if the player itself has been turned off.
- If you are not going to use the player for a long time, be sure to disconnect the player from the wall outlet. To disconnect the AC power cord (mains lead), grasp the plug itself; never pull the cord.

On placement

- Place the player in a location with adequate ventilation to prevent heat build-up in the player.
- Do not place the player on a soft surface such as a rug.
- Do not place the player in a location near heat sources, or in a place subject to direct sunlight, excessive dust, or mechanical shock.

On operation

- If the player is brought directly from a cold to a warm location, or is placed in a very damp room, moisture may condense on the lenses inside the player. Should this occur, the player may not operate properly. In this case, remove the disc and leave the player turned on for about half an hour until the moisture evaporates.
- When you move the player, take out any discs. If you don't, the disc may be damaged.

On adjusting volume

Do not turn up the volume while listening to a section with very low level inputs or no audio signals. If you do, the speakers may be damaged when a peak level section is played.

On cleaning

Clean the cabinet, panel, and controls with a soft cloth slightly moistened with a mild detergent solution. Do not use any type of abrasive pad, scouring powder or solvent such as alcohol or benzine.

On cleaning discs, disc/lens cleaners

Do not use a commercially available cleaning disc or disc/lens cleaner (wet or spray type). These may cause the apparatus to malfunction.

IMPORTANT NOTICE

Caution: This player is capable of holding a still video image or on-screen display image on your television screen indefinitely. If you leave the still video image or on-screen display image displayed on your TV for an extended period of time you risk permanent damage to your television screen. Plasma display panel televisions and projection televisions are susceptible to this.

If you have any questions or problems concerning your player, please consult your nearest Sony dealer.

About This Manual

•Instructions in this manual describe the controls on the remote. You can also use the controls on the player if they have the same or similar names as those on the remote.

•“DVD” may be used as a general term for DVD VIDEOS, DVD+RWs/DVD+Rs (+VR mode) and DVD-RWs/DVD-Rs (video mode).

•The meaning of the icons used in this manual is described below:

| Icons | Meaning |
|-------|---|
| | Functions available for DVD VIDEOS and DVD+RWs/DVD+Rs in +VR mode or DVD-RWs/DVD-Rs in video mode |
| | Functions available for DVD-RWs/DVD-Rs in VR (Video Recording) mode |
| | Functions available for VIDEO CDs (including Super VCDs or CD-Rs/CD-RWs in video CD format or Super VCD format) |
| | Functions available for music CDs or CD-Rs/CD-RWs in music CD format |
| | Functions available for DATA CDs (CD-ROMs/CD-Rs/CD-RWs containing MP3 ¹ audio tracks, JPEG image files, and DivX ^{2,3} video files) |
| | Functions available for DATA DVDs (DVD-ROMs/DVD+RWs/DVD+Rs/DVD-RWs/DVD-Rs containing MP3 ¹ audio tracks, JPEG image files and DivX ^{2,3} video files) |

¹ MP3 (MPEG-1 Audio Layer III) is a standard format defined by ISO (International Organization for Standardization)/IEC (International Electrotechnical Commission) MPEG which compresses audio data.

² DivX[®] is a video file compression technology, developed by DivX, Inc.

³ DivX, DivX Certified, and associated logos are trademarks of DivX, Inc. and are used under license.

This Player Can Play the Following Discs

| Format of discs | Discs |
|-----------------------|-------|
| DVD VIDEO | |
| DVD-RW/R | |
| DVD+RW/+R | |
| VIDEO CD/ Music CD | |
| CD-RW/R | |

“DVD+RW,” “DVD-RW,” “DVD+R,” “DVD-R,” “DVD-VIDEO” and the “CD” logo are trademarks.

Note about CDs/DVDs

The player can play CD-ROMs/CD-Rs/CD-RWs recorded in the following formats:

- music CD format
- video CD format
- MP3 audio tracks, JPEG image files, and DivX video files of format conforming to ISO 9660[®] Level 1/Level 2, or its extended format, Joliet
- KODAK Picture CD format

[®] A logical format of files and folders on CD-ROMs, defined by ISO (International Organization for Standardization).

The player can play DVD-ROMs/DVD+RWs/DVD-RWs/DVD+Rs/DVD-Rs recorded in the following formats:

- MP3 audio tracks, JPEG image files and DivX video files of format conforming to UDF (Universal Disk Format).

Example of discs that the player cannot play

The player cannot play the following discs:

- CD-ROMs/CD-Rs/CD-RWs other than those recorded in the formats listed on this page.
- CD-ROMs recorded in PHOTO CD format.
- Data part of CD-Extras.
- DVD Audio discs.
- HD layer on Super Audio CDs.
- DATA DVDs that do not contain MP3 audio tracks, JPEG image files, or DivX video files.

Also, the player cannot play the following discs:

- A DVD VIDEO with a different region code.
- A disc that has a non-standard shape (e.g., card, heart).
- A disc with paper or stickers on it.
- A disc that has the adhesive of cellophane tape or a sticker still left on it.

Region code

Your player has a region code printed on the back of the unit and only will play DVD VIDEOS (playback only) labelled with identical region codes. This system is used to protect copyrights.

DVD VIDEOS labelled will also play on this player.

If you try to play any other DVD VIDEO, the message “Playback prohibited by area limitations.” will appear on the TV screen. Depending on the DVD VIDEO, there may be no region code indication, even though playing the DVD VIDEO is prohibited by area restrictions.



Notes

- **Notes about DVD+RWs/DVD+Rs, DVD-RWs/DVD-Rs or CD-Rs/CD-RWs**
Some DVD+RWs/DVD+Rs, DVD-RWs/DVD-Rs, or CD-Rs/CD-RWs cannot be played on this player due to the recording quality or physical condition of the disc, or the characteristics of the recording device and authoring software.
The disc will not play if it has not been correctly finalized. For more information, refer to the operating instructions for the recording device.
Note that some playback functions may not work with some DVD+RWs/DVD+Rs, even if they have been correctly finalized. In this case, view the disc by normal playback. Also some DATA CDs/DATA DVDs created in Packet Write format cannot be played.
- **Music discs encoded with copyright protection technologies**
This product is designed to playback discs that conform to the Compact Disc (CD) standard. Recently, various music discs encoded with copyright protection technologies are marketed by some record companies. Please be aware that among those discs, there are some that do not conform to the CD standard and may not be playable by this product.
- **Note on DualDiscs**
A DualDisc is a two sided disc product which mates DVD recorded material on one side with digital audio material on the other side. However, since the audio material side does not conform to the Compact Disc (CD) standard, playback on this product is not guaranteed.

Copyrights

This product incorporates copyright protection technology that is protected by U.S. patents and other intellectual property rights. Use of this copyright protection technology must be authorized by Macrovision, and is intended for home and other limited viewing uses only unless otherwise authorized by Macrovision. Reverse engineering or disassembly is prohibited.

Note on playback operations of DVDs and VIDEO CDs

Some playback operations of DVDs and VIDEO CDs may be intentionally set by software producers. Since this player plays DVDs and VIDEO CDs according to the disc contents the software producers designed, some playback features may not be available. Also, refer to the instructions supplied with the DVDs or VIDEO CDs.

Index to Parts and Controls

For more information, see the pages indicated in parentheses.

Front panel

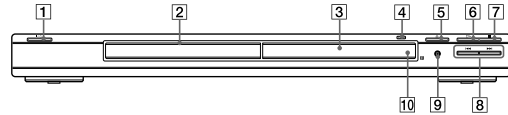

- 1 I/⏻ (on/standby) button (24)
- 2 Disc tray (24)
- 3 Front panel display (10)
- 4 HDMI* (High-Definition Multimedia Interface) indicator (17, 66, 69, 77)
Lights up when the HDMI OUT jack is correctly connected to a HDCP (High-bandwidth Digital Content Protection) compliant device with HDMI or DVI (Digital Visual Interface) input.
- 5 ⏻ (open/close) button (24)
- 6 ▷ (play) button (24)
- 7 ■ (stop) button (25)
- 8 ◀▶ (previous/next) buttons (33)
- 9 PROGRESSIVE button/indicator (18)
Lights up when the player outputs progressive signals.
- 10 Remote sensor (15)

* This player is based on version 1.1 of High-Definition Multimedia Interface Specifications.

This DVD player incorporates High-Definition Multimedia Interface (HDMI™) technology.

HDMI, the HDMI logo and High-Definition Multimedia Interface are trademarks or registered trademarks of HDMI Licensing LLC.

Rear panel

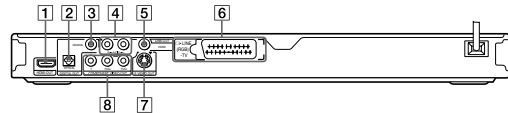

- 1 HDMI OUT (high-definition multimedia interface out) jack (16)
- 2 DIGITAL OUT (OPTICAL) jack (20)
- 3 DIGITAL OUT (COAXIAL) jack (20)
- 4 LINE OUT L/R (AUDIO) jacks (20)
- 5 LINE OUT (VIDEO) jack (16)
- 6 LINE (RGB) - TV jack (16)
- 7 S VIDEO OUT jack (16)
- 8 COMPONENT VIDEO OUT jacks (16) (Y, Pb/Cb, Pr/Cr)

→ continued 9

Front panel display

When playing back a DVD VIDEO/DVD-VR mode disc

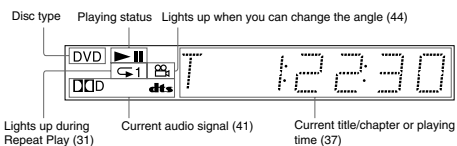

When playing back a VIDEO CD with Playback Control (PBC) (28)

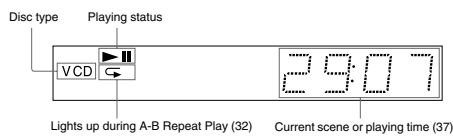

When playing back a CD, DATA DVD (MP3 audio/DivX video), DATA CD (MP3 audio/DivX video), or VIDEO CD (without PBC)

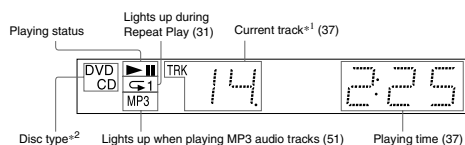

*1 When playing DivX video files, the current track is not displayed.
*2 When playing DATA DVDs, the DVD indicator is displayed.
When playing VIDEO CDs (without PBC), the VCD indicator is displayed.

Remote

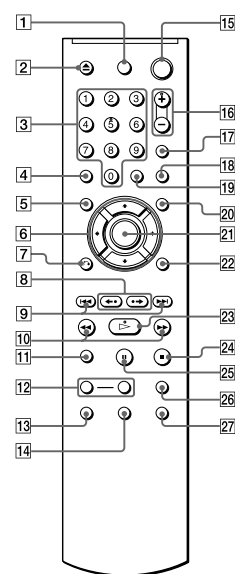

- 9 ◀▶ (previous/next) buttons (25)
- 10 ◀◀▶▶ (scan/slow) buttons (34)
- 11 ZOOM button (25, 54)
- 12 SLOW PLAY/FAST PLAY buttons (25)
- 13 🔊 (audio) button (40)
- 14 ⏴ (subtitle) button (44)
- 15 I/⏻ (on/standby) button (24)
- 16 🔊 (volume) +/- buttons (63)
The + button has a tactile dot.*
- 17 ⏴ (TV/video) button (63)
- 18 PICTURE NAVI (picture navigation) button (36, 54)
- 19 TIME/TEXT button (37)
- 20 MENU button (27)
- 21 ENTER button (22)
- 22 DISPLAY button (12)
- 23 ▷ (play) button (24)
The ▷ button has a tactile dot.*
- 24 ■ (stop) button (25)
- 25 ⏸ (pause) button (25)
- 26 SUR (surround) button (42)
- 27 🔊 (angle) button (44)

* Use the tactile dot as a reference when operating the player.

- 1 I/⏻ (on/standby) button (63)
- 2 ⏻ (open/close) button (25)
- 3 Number buttons (27)
The number 5 button has a tactile dot.*
- 4 CLEAR button (29)
- 5 TOP MENU button (27)
- 6 ⏴/⏵/⏶/⏷ buttons (27)
- 7 ⏴ RETURN (return) button (24, 25)
- 8 ◀◀/▶▶ (replay/step/advance/step) buttons (25, 34)

Guide to the Control Menu Display (Magic Pad)

Use the Control Menu to select a function and to view related information. Press DISPLAY repeatedly to turn on or change the Control Menu display as follows:

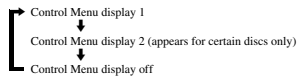

Control Menu display

The Control Menu display 1 and 2 will show different items depending on the disc type. For details about each item, see the pages in parentheses.

Example: Control Menu display 1 when playing a DVD VIDEO.

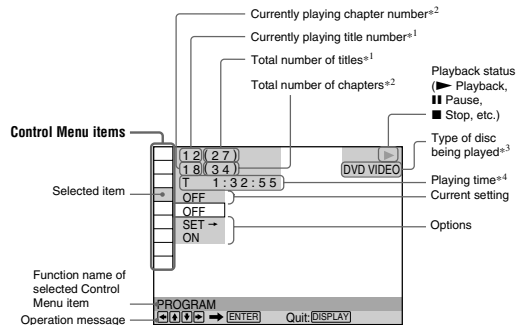

*1 Displays the scene number for VIDEO CDs (PBC is on), track number for VIDEO CDs/CDs, album number for DATA CDs/DATA DVDs.
 *2 Displays the index number for VIDEO CDs, MP3 audio track number or JPEG image file number for DATA CDs/DATA DVDs, DivX video file number for DATA CDs/DATA DVDs.
 *3 Displays Super VCD as "SVCD."
 *4 Displays the date for JPEG files.

To turn off the display
 Press DISPLAY repeatedly.

List of Control Menu items

| Item | Item Name, Function |
|------|--|
| | TITLE (page 34)/SCENE (page 34)/TRACK (page 34) Selects the title, scene, or track to be played. |
| | CHAPTER (page 34)/INDEX (page 34) Selects the chapter or index to be played. |
| | TRACK (page 34) Selects the track to be played. |
| | ORIGINAL/PLAY LIST (page 27) Selects the type of titles (DVD-RW/DVD-R in VR mode) to be played, the ORIGINAL one, or an edited PLAY LIST. |
| | TIME/TEXT (page 34) Checks the elapsed time and the remaining playback time. Input the time code for picture and music searching. Displays the DVD/CD text, or the DATA CD/DATA DVD track/file name. |
| | PROGRAM (page 29) Selects the title, chapter, or track to play in the order you want. |
| | SHUFFLE (page 30) Shuffles the title, chapter, or track in random order. |
| | REPEAT (page 31) Plays the entire disc (all titles/all tracks/all albums) repeatedly or one title/chapter/track/album/file repeatedly. |
| | A-B REPEAT (page 32) Specifies the parts you want to play repeatedly. |
| | CUSTOM PICTURE MODE (page 45) Adjusts the video signal from the player. You can select the picture quality that best suits the program you are watching. |
| | SHARPNESS (page 47) Exaggerates the outline of the image to produce a sharper picture. |
| | BNR (page 48) Adjusts the picture quality by reducing the "block noise" or mosaic like patterns that appear on your TV screen. |
| | MNR (page 48) Adjusts the picture quality by reducing the faint noise appearing around the outlines of the images. |
| | AV SYNC (page 49) Adjust the delay between the picture and sound. |
| | PARENTAL CONTROL (page 60) Set to prohibit playback on this player. |
| | SETUP (page 64) QUICK Setup (page 22) Use Quick Setup to choose the desired language of the on-screen display, the aspect ratio of the TV and, the audio output signal. CUSTOM Setup In addition to the Quick Setup setting, you can adjust various other settings. RESET Returns the settings in "SETUP" to the default setting. |
| | ALBUM (page 34) Selects the album that contains MP3 audio track and JPEG image file to be played. |

| | |
|--|---|
| | FILE (page 34) Selects the JPEG image file to be played. |
| | ALBUM (page 34) Selects the album that contain DivX video file to be played. |
| | FILE (page 34) Selects the DivX video file to be played. |
| | DATE (page 54) Displays the date the picture was taken by a digital camera. |
| | INTERVAL (page 56) Specifies the duration for which the slides are displayed on the screen. |
| | EFFECT (page 56) Selects the effects to be used for changing slides during a slide show. |
| | MODE (MP3, JPEG) (page 55) Selects the data type: MP3 audio track (AUDIO), JPEG image file (IMAGE) or both (AUTO) to be played when playing a DATA CD/DATA DVD. |

Hint
 The Control Menu icon indicator lights up in green when you select any item except "OFF," ("PROGRAM," "SHUFFLE," "REPEAT," "A-B REPEAT," "SHARPNESS," "CUSTOM PICTURE MODE," "BNR," "MNR" only). The "ORIGINAL/PLAY LIST" indicator lights up in green when you select "PLAY LIST" (default setting). The "AV SYNC" indicator lights up in green when set to more than 0 ms.

Hookups

Hooking Up the Player

Follow steps 1 to 6 to hook up and adjust the settings of the player.

Notes

- Plug cords securely to prevent unwanted noise.
- Refer to the instructions supplied with the components to be connected.
- You cannot connect this player to a TV that does not have a SCART or video input jack.
- Be sure to disconnect the mains lead of each component before connecting.

Step 1: Unpacking

Check that you have the following items:

- Audio/video cord (phono plug × 3 ↔ phono plug × 3) (1)
- Remote commander (remote) (1)
- R6 (size AA) batteries (2)

Step 2: Inserting Batteries Into the Remote

You can control the player using the supplied remote. Insert two R6 (size AA) batteries by matching the ⊕ and ⊖ ends on the batteries to the markings inside the compartment. When using the remote, point it at the remote sensor on the player.

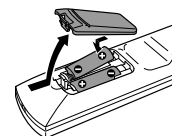

Notes

- Do not leave the remote in an extremely hot or humid place.
- Do not drop any foreign object into the remote casing, particularly when replacing the batteries.
- Do not expose the remote sensor to direct light from the sun or a lighting apparatus. Doing so may cause a malfunction.
- If you do not use the remote for an extended period of time, remove the batteries to avoid possible damage from battery leakage and corrosion.

Step 3: Connecting the Video Cords/HDMI Cords

Connect this player to your TV monitor, projector, or AV amplifier (receiver) using a video cord. Select one of the patterns **A** through **E**, according to the input jack on your TV monitor, projector, or AV amplifier (receiver). In order to view progressive signal (525p or 625p) pictures with a compatible TV, projector, or monitor, you must use pattern **D**. Select pattern **E** when connecting to a TV, projector, or AV amplifier (receiver) equipped with HDMI input.

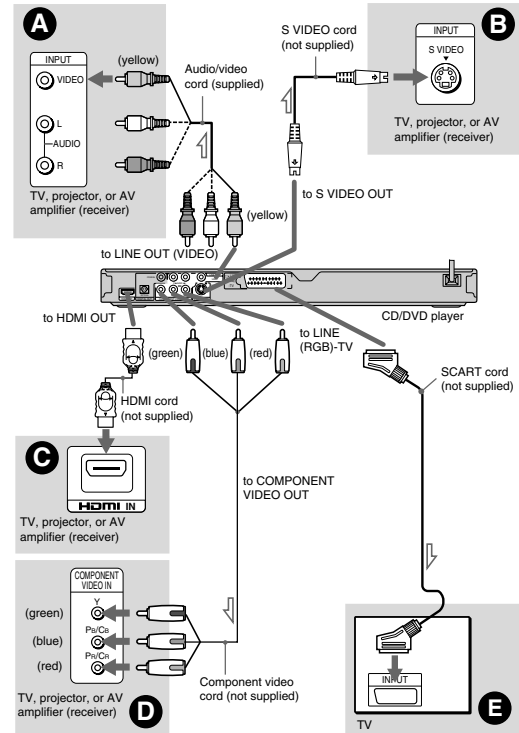

16 → : Signal flow

Note

When connecting to a progressive TV, it is recommended that you use only pattern **E**. If you connect to your TV using both **D** and **E**, a special control signal transmitted via the SCART cable may cause the signal to be switched to the SCART jack.

A If you are connecting to a video input jack

Connect the yellow plug of an audio/video cord (supplied) to the yellow (video) jack. You will enjoy standard quality images.

With this connection, select "NORMAL (INTERLACE)" (default) by pressing the PROGRESSIVE button on the front panel.

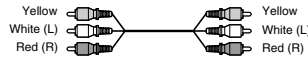

B If you are connecting to an S VIDEO input jack

Connect an S VIDEO cord (not supplied). You will enjoy high quality images. With this connection, select "NORMAL (INTERLACE)" (default) by pressing the PROGRESSIVE button on the front panel.



C If you are connecting to an HDMI/DVI input jack

Use a certified Sony HDMI cord (not supplied) to enjoy high quality digital picture and sound through the HDMI OUT jack. When connecting to the HDMI OUT jack, carefully align the HDMI connector with the jack. Do not bend and apply pressure to the HDMI cord.

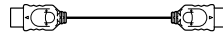

To connect to a TV with DVI input

Use an HDMI-DVI converter cord (not supplied). The DVI jack will not accept any audio signals, so you have to use another audio connection in addition to this connection (page 20). Furthermore, you cannot connect the HDMI OUT jack to DVI jacks that are not HDCP compliant (e.g., DVI jacks on PC displays).

D If you are connecting to a monitor, projector, or AV amplifier (receiver) having component video input jacks (Y, Pb/Cb, Pr/Cr)

Connect the component via the COMPONENT VIDEO OUT jacks using a component video cord (not supplied) or three video cords of the same kind and length. You will enjoy accurate colour reproduction and high quality images.

If your TV accepts progressive 525p/625p format signals, use this connection and press the PROGRESSIVE button on the front panel to output progressive signals. For details, see "Using the PROGRESSIVE button" (page 18).

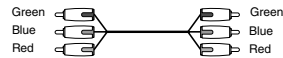

HeadUps

HeadUps

→ continued 17

E If you are connecting to a SCART input jack

Connect a SCART cord (not supplied). Be sure to make the connections firmly to avoid hum and noise. When you connect using the SCART cord, check that the TV conforms to S video or RGB signals. Refer to the operating instructions supplied with the TV to be connected. Also, when you set "LINE" to "S VIDEO" or "RGB" under "SCREEN SETUP" in the Setup Display (page 67), use a SCART cord that conforms to each signal.

With this connection, select "NORMAL (INTERLACE)" (default) by pressing the PROGRESSIVE button on the front panel.



When connecting to a standard 4:3 screen TV

Depending on the disc, the image may not fit your TV screen. To change the aspect ratio, see page 66.

Notes

• Do not connect a VCR, etc., between your TV and the player. If you pass the player signals via the VCR, you may not receive a clear image on the TV screen. If your TV has only one audio/video input jack, connect the player to this jack.

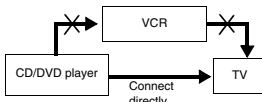

• If you set "LINE" in SCREEN SETUP to "RGB" (page 67), the player outputs no component video signals.

When you play a disc recorded in the NTSC colour system, the player outputs the video signal or the Setup Display etc. in the NTSC colour system and the picture may not appear on the PAL colour system televisions. In this case, open the tray and remove the disc.

Using the PROGRESSIVE button

By using the PROGRESSIVE button on the front panel, you can select the signal format in which the player outputs video signals (Progressive or Interlace), and the conversion method for progressive signals. The PROGRESSIVE indicator lights up when the player outputs progressive signals.

Each time you press the PROGRESSIVE button, the display changes as follows:

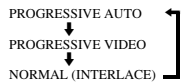

◆PROGRESSIVE AUTO

Select this setting when:

- your TV accepts progressive signals, and
 - the TV is connected to the COMPONENT VIDEO OUT jacks.
- Normally select this under the above condition. This automatically detects the software type, and selects the appropriate conversion method.

Note that the picture will not be clear or no picture will appear if you select these settings when either of the above conditions is not met.

◆PROGRESSIVE VIDEO

Select this setting when:

- your TV accepts progressive signals, and
- the TV is connected to the COMPONENT VIDEO OUT jacks, and
- you want to fix the conversion method to PROGRESSIVE VIDEO for video-based software.

Select this if the image is not clear when you select PROGRESSIVE AUTO.

Note that the picture will not be clear or no picture will appear if you select these settings when either of the above conditions is not met.

◆NORMAL (INTERLACE)

Select this setting when:

- your TV does not accept progressive signals, or
- your TV is connected to jacks other than the COMPONENT VIDEO OUT jacks (LINE OUT (VIDEO) or S VIDEO OUT).

You cannot select this setting while the HDMI indicator is lit.

About DVD software types and the conversion method

DVD software can be divided into two types: film-based software and video-based software. Video-based software is derived from TV, such as dramas and sit-coms, and displays images at 25 frames/50 fields (30 frames/60 fields) per second. Film-based software is derived from film and displays images at 24 frames per second. Some DVD software contains both video and film. In order for these images to appear natural on your screen when output in progressive format, the progressive signals need to be converted to match the type of DVD software that you are watching.

Notes

• When you play video-based software in progressive signal format, sections of some types of images may appear unnatural due to the conversion process when output through the COMPONENT VIDEO OUT jacks. Images from the S VIDEO OUT and LINE OUT (VIDEO) jacks are unaffected as they are output in the normal (interlace) format.

• If you set "LINE" in "SCREEN SETUP" to "RGB," then the player switches to "NORMAL (INTERLACE)." This will happen even though you select "PROGRESSIVE AUTO" or "PROGRESSIVE VIDEO."

Step 4: Connecting the Audio Cords

Select one of the following patterns **A**, or **B** according to the input jack on your TV monitor, projector, or AV amplifier (receiver). This will enable you to listen to sound.

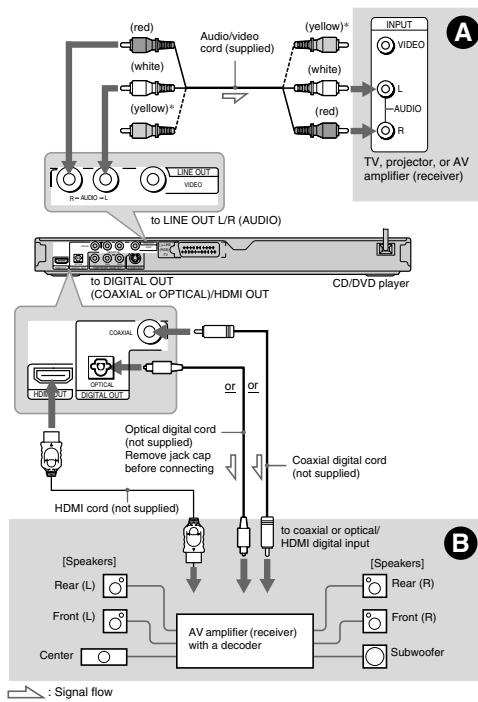

* The yellow plug is used for video signals (page 16).
Hint
 For correct speaker location, see the operating instructions supplied with the connected components.

A Connecting to audio L/R input jacks

This connection will use your TV's or stereo amplifier's (receiver's) two speakers for sound. Connect using the audio/video cord (supplied).

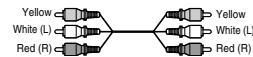

• Surround effect (page 42)
 TV: Dynamic Theatre, Dynamic, Wide, Night



Stereo amplifier (receiver): Standard, Night

B Connecting to a digital audio input jack

If your AV amplifier (receiver) has a Dolby Digital^{®1}, DTS^{®2} or MPEG audio decoder and a digital input jack, use this connection. Connect using a coaxial or optical digital cord/HDMI cord (not supplied).

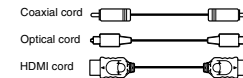

• Surround effect
 Dolby Digital (5.1ch), DTS (5.1ch), MPEG audio (5.1ch)



Headups

¹ Manufactured under license from Dolby Laboratories.
 "Dolby," "Pro Logic," and the double-D symbol are trademarks of Dolby Laboratories.
² "DTS" and "DTS Digital Out" are trademarks of Digital Theater Systems, Inc.

Notes

- After you have completed the connection, be sure to set "DOLBY DIGITAL" to "DOLBY DIGITAL" and "DTS" to "ON" in Quick Setup (page 22). If your AV amplifier (receiver) has an MPEG audio decoder function, set "MPEG" to "MPEG" in Audio Setup (page 71). Otherwise, no sound or a loud noise will come from your speakers.
- When you connect an amplifier (receiver) that conforms to the 96 kHz sampling frequency, set "48kHz/96kHz PCM" in "AUDIO SETUP" to "96kHz/24bit" (page 71).
- The TV's effects of this player cannot be used with this connection.
- When you connect the player to an AV amplifier (receiver) using an HDMI cord, you will need to do one of the following:
 - Connect the AV amplifier (receiver) to the TV with the HDMI cord.
 - Connect the player to the TV with a video cord other than HDMI cord (component video cord, S VIDEO cord, or audio/video cord).
- When connecting to the HDMI OUT jack, carefully align the HDMI connector with the jack. Do not bend and apply pressure to the HDMI cord.

Headups

Step 5: Connecting the Mains Lead

Plug the player and TV mains lead (power cord) into a mains.

Step 6: Quick Setup

Follow the steps below to make the minimum number of basic adjustments for using the player. To skip an adjustment, press **▶▶1**. To return to the previous adjustment, press **◀◀1**.

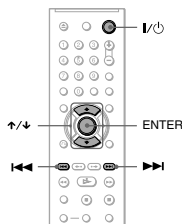

1 Turn on the TV.

2 Press I/⏻.

3 Switch the input selector on your TV so that the signal from the player appears on the TV screen.

"Press [ENTER] to run QUICK SETUP" (press enter to run Quick Setup) appears at the bottom of the screen. If this message does not appear, select "QUICK" (quick) under "SETUP" (setup) in the Control Menu to run Quick Setup (page 65).

4 Press ENTER without inserting a disc.

The Setup Display for selecting the language used in the on-screen display appears.

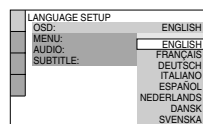

5 Press ↕ to select a language.

The player displays the menu and subtitles in the selected language.

6 Press ENTER.

The Setup Display for selecting the aspect ratio of the TV to be connected appears.

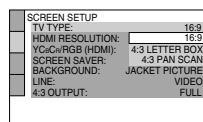

7 Press ↕ to select the setting that matches your TV type.

- ◆ If you have a wide-screen TV or a 4:3 standard TV with a wide-screen mode
 - 16:9 (page 66)
- ◆ If you have a 4:3 standard TV
 - 4:3 LETTER BOX or 4:3 PAN SCAN (page 66)

8 Press ENTER.

The Setup Display for selecting the type of jack used to connect your amplifier (receiver) appears.

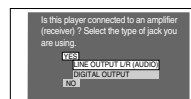

9 Press ↕ to select the type of jack (if any) you are using to connect to an amplifier (receiver), then press ENTER.

If you did not connect an AV amplifier (receiver), select "NO," then go to step 13.
 If you connected an AV amplifier (receiver) using just an audio cord, select "YES: LINE OUTPUT L/R (AUDIO)," then go to step 13.
 If you connected an AV amplifier (receiver) using either an optical or coaxial digital/HDMI cord, select "YES: DIGITAL OUTPUT." The Setup Display for "DOLBY DIGITAL" appears.

10 Press ↕ to select the type of Dolby Digital signal you wish to send to your amplifier (receiver).

If your AV amplifier (receiver) has a Dolby Digital decoder, select "DOLBY DIGITAL." Otherwise, select "D-PCM."

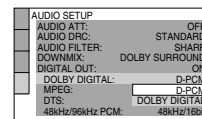

11 Press ENTER.

"DTS" is selected.

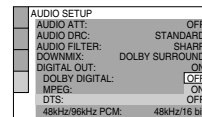

12 Press ↕ to select whether or not you wish to send a DTS signal to your amplifier (receiver).

If your AV amplifier (receiver) has a DTS decoder, select "ON." Otherwise, select "OFF."

13 Press ENTER.

◆ When "DIGITAL OUTPUT" is selected in step 9

- Quick Setup is finished and connections are complete.
- If your AV amplifier (receiver) has an MPEG audio decoder, set "MPEG" to "MPEG" (page 71).

Playing Discs

Playing Discs DVDVideo DVDVR VCD CD DATA CD DATA DVD

Depending on the DVD or VIDEO CD, some operations may be different or restricted. Refer to the operating instructions supplied with your disc.

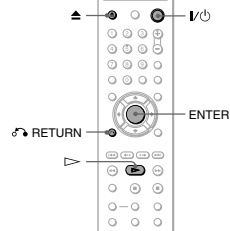

- 1 Turn on your TV.
- 2 Press I/O. The player turns on.
- 3 Switch the input selector on your TV so that the signal from the player appears on the TV screen.
 - ◆ When using an amplifier (receiver) Turn on the amplifier (receiver) and select the appropriate channel so that you can hear sound from the player.

- 4 Press on the player, and place a disc on the disc tray.



- 5 Press . The disc tray closes. The player starts playback (continuous play). Adjust the volume on the TV or the amplifier (receiver). Depending on the disc, a menu may appear on the TV screen. For DVD VIDEOS, see page 27. For VIDEO CDs, see page 28.

To turn off the player
Press I/O. The player enters standby mode.

Hint
You can have the player turn off automatically whenever you leave it in stop mode for more than 30 minutes. To turn this function on or off, set "AUTO POWER OFF" in "CUSTOM SETUP" to "ON" or "OFF" (page 68).

Notes on playing DTS sound tracks on a DVD VIDEO

- DTS audio signals are output only through the DIGITAL OUT (COAXIAL or OPTICAL)/HDMI OUT jack.
- When you play a DVD VIDEO with DTS sound tracks, set "DTS" to "ON" in "AUDIO SETUP" (page 71).
- If you connect the player to audio equipment without a DTS decoder, do not set "DTS" to "ON" in "AUDIO SETUP" (page 71). A loud noise may come out from the speakers, affecting your ears or causing the speakers to be damaged.

Note
Discs created on DVD recorders must be correctly finalized before they can be played. For more information about finalizing, refer to the operating instructions supplied with the DVD recorder.

Additional operations

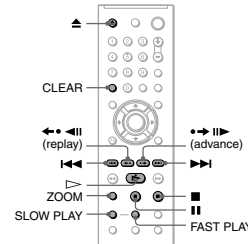

| To | Operation |
|--|---|
| Stop | Press |
| Pause | Press |
| Resume play after pause | Press or |
| Go to the next chapter, track, or scene in continuous play mode | Press |
| Go back to the previous chapter, track, or scene in continuous play mode | Press |
| Stop play and remove the disc | Press |
| Replay the previous scene*1 | Press (replay) during playback |
| Briefly fast forward the current scene*2 | Press (advance) during playback |
| Magnify the image*3 | Press ZOOM repeatedly. Press CLEAR to cancel. |

*1 DVD VIDEOS/DVD-RWs/DVD-Rs only. The button can be used except for DivX video files.
*2 DVD VIDEOS/DVD-RWs/DVD-Rs/DVD+RWs/DVD+Rs only. The button can be used except for DivX video files.
*3 Video and JPEG pictures only (except BACKGROUND pictures). You can move the enlarged picture using / . Depending upon the contents of the disc, the zoom function may be cancelled automatically when the picture is moved.

Note
You may not be able to use the Replay or Advance function with some scenes.

Playing quickly or slowly with sound

You can listen to dialogue or sound while playing the current scene quickly or slowly. During playback, press FAST PLAY or SLOW PLAY. The speed changes when you press either FAST PLAY or SLOW PLAY.

To return to normal playback
Press .

Notes

- You can only use this function with DVDs/VIDEO CDs/Super VCDs and DVD-RWs/DVD-Rs in VR mode only.
- "Operation not possible" will appear when maximum or minimum speed is reached.
- During Fast Play and Slow Play mode, you cannot change angle (page 44), subtitle (page 44), and the sound (page 40). The sound can only be changed for VIDEO CDs/Super VCDs.
- Fast Play and Slow Play functions do not work when playing DTS sound tracks.
- You cannot use Fast Play and Slow Play function when playing a still picture on DVD-RW/DVD-R in VR mode.

Locking the disc tray (Child Lock)

You can lock the disc tray to prevent children from opening it.

When the player is in standby mode, press , ENTER, and then I/O on the remote.

The player turns on and "LOCKED" appears on the front panel display. The and buttons on the player or the remote do not work while the Child Lock is set.

To unlock the disc tray
When the player is in standby mode, press , ENTER, and then I/O again.

Note
Even if you select "RESET" under "SETUP" in the Control Menu (page 65), the disc tray remains locked.

Playing Discs

Playing Discs

Resuming Playback From the Point Where You Stopped the Disc (Multi-disc Resume) DVDVideo VCD

The player stores the point where you stopped the disc for up to 6 discs and resumes playback the next time you insert the same disc. If you store a resume playback point for the 7th disc, the resume playback point for the first disc is deleted.



- 1 While playing a disc, press to stop playback. "RESUME" appears on the front panel display.
- 2 Press . The player starts playback from the point where you stopped the disc in step 1.

Hint
To play from the beginning of the disc, press twice, then press .

Notes

- "MULTI-DISC RESUME" in "CUSTOM SETUP" must be set to "ON" (default) for this function to work (page 68).
- The point where you stopped playing is cleared when:
 - you change the play mode.
 - you change the settings on the Setup Display.
- For DVD-RWs/DVD-Rs in VR mode, CDs, DATA CDs, and DATA DVDs, the player remembers the resume playback point for the current disc. The resume point is cleared when:
 - you opened the disc tray.
 - you disconnect the mains lead
 - the player enters standby mode (DATA CD/ DATA DVD only).
- Resume Play does not work during Shuffle Play and Programme Play.
- This function may not work with some discs.
- If "MULTI-DISC RESUME" in "CUSTOM SETUP" is set to "ON" and you playback a recorded disc such as DVD-RW, the player may playback other recorded discs from the same resume point.

Using the DVD's Menu DVDVideo

A DVD is divided into long sections of a picture or a music feature called "titles." When you play a DVD which contains several titles, you can select the title you want using the TOP MENU button. When you play DVDs that allow you to select items such as language for the sound and subtitles, select these items using the MENU button.

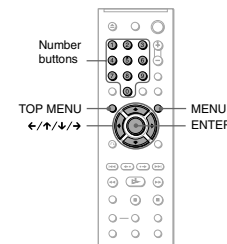

- 1 Press TOP MENU or MENU. The disc's menu appears on the TV screen. The contents of the menu vary from disc to disc.
- 2 Press / or the number buttons to select the item you want to play or change. If you press the number buttons, the following display appears. Press the number buttons to select the item you want.
- 3 Press ENTER.

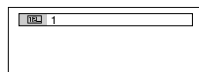

Selecting "ORIGINAL" or "PLAY LIST" on a DVD-RW/DVD-R DVDVR

Some DVD-RWs/DVD-Rs in VR (Video Recording) mode have two types of titles for playback: originally recorded titles (ORIGINAL) and titles that can be created on recordable DVD players for editing (PLAY LIST). You can select the type of title to be played.

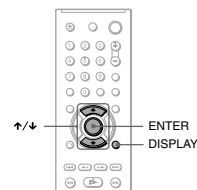

- 1 Press DISPLAY when the player is in stop mode. The Control Menu appears.
- 2 Press to select , then press ENTER. The options for "ORIGINAL/PLAY LIST" appear.
- 3 Press to select a setting.
 - PLAY LIST: plays the titles created from "ORIGINAL" for editing.
 - ORIGINAL: plays the titles originally recorded.
- 4 Press ENTER.

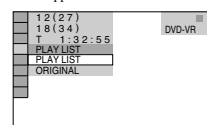

Playing VIDEO CDs With PBC Functions (PBC Playback) **VCD**

PBC (Playback Control) allows you to play VIDEO CDs interactively by following the menu on the TV screen.

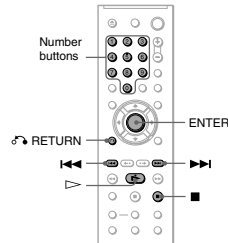

1 Start playing a VIDEO CD with PBC functions.

The menu for your selection appears.

2 Press the number buttons to select the item number you want.

3 Press ENTER.

4 Follow the instructions in the menu for interactive operations.

Refer to the instructions supplied with the disc, as the operating procedure may differ depending on the VIDEO CD.

To return to the menu
Press **RETURN**.

Hint
To play without using PBC, press **STOP** or the number buttons while the player is stopped to select a track, then press **ENTER**.
"Play without PBC" appears on the TV screen and the player starts continuous play. You cannot play still pictures such as a menu.
To return to PBC playback, press **ENTER** twice then press **ENTER**.

Note
Depending on the VIDEO CD, "Press ENTER" in step 3 may appear as "Press SELECT" in the instructions supplied with the disc. In this case, press **ENTER**.

Various Play Mode Functions (Programme Play, Shuffle Play, Repeat Play, A-B Repeat Play)

You can set the following play modes:
• Programme Play (page 29)
• Shuffle Play (page 30)
• Repeat Play (page 31)
• A-B Repeat Play (page 32)

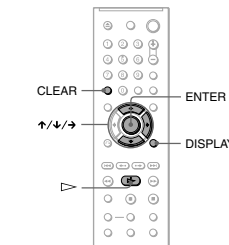

Note
The play mode is cancelled when:
- you eject the disc.
- the player enters standby mode by pressing **POWER**.

Creating your own programme (Programme Play) **DVDVIDEO VCD CD**

You can play the contents of a disc in the order you want by arranging the order of the titles, chapters, or tracks on the disc to create your own programme. You can programme up to 99 titles, chapters, and tracks.

- Press DISPLAY.**
The Control Menu appears.
- Press \uparrow/\downarrow to select **PROGRAM** (PROGRAM), then press ENTER.**
The options for "PROGRAM" appear.

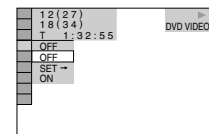

3 Press \uparrow/\downarrow to select "SET →," then press ENTER.

"TRACK" is displayed when you play a VIDEO CD, or CD.

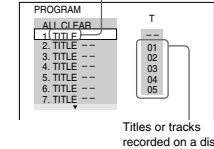

4 Press →.
The cursor moves to the title or track row "T" (in this case, "01").

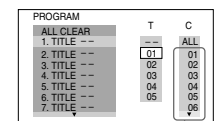

5 Select the title, chapter, or track you want to programme.

◆ **When playing a DVD VIDEO**
For example, select chapter "03" of title "02."
Press \uparrow/\downarrow to select "02" under "T," then press ENTER.

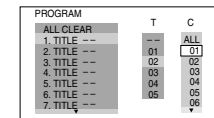

Playing Discs

Playing Discs

Playing Discs

→ continued 29

Next, press \uparrow/\downarrow to select "03" under "C," then press ENTER.

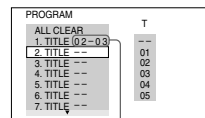

Selected title and chapter

◆ **When playing a VIDEO CD, or CD**
For example, select track "02."
Press \uparrow/\downarrow to select "02" under "T," then press ENTER.

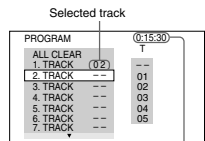

Total time of the programmed tracks

6 To programme other titles, chapters, or tracks, repeat steps 4 to 5.
The programmed titles, chapters, and tracks are displayed in the selected order.

7 Press \triangleright to start Programme Play.
Programme Play begins.
When the programme ends, you can restart the same programme again by pressing \triangleright .

To return to normal play
Press CLEAR, or select "OFF" after step 2. To play the same programme again, select "ON" in step 3 and press ENTER.

To change or cancel a programme

1 Follow steps 1 to 3 of "Creating your own programme (Programme Play)."

- Select the programme number of the title, chapter, or track you want to change or cancel using \uparrow/\downarrow and press **→**. If you want to delete the title, chapter, or track from the programme, press CLEAR.
- Follow step 5 for new programming. To cancel a programme, select "--" under "T," then press ENTER.

To cancel all of the titles, chapters, or tracks in the programmed order

- Follow steps 1 to 3 of "Creating your own programme (Programme Play)."
- Press **→** and select "ALL CLEAR."
- Press ENTER.

Hint
You can perform Repeat Play or Shuffle Play of programmed titles, chapters, or tracks. During Programme Play, follow the steps of Repeat Play (page 31) or Shuffle Play (page 30).

Notes
• When you programme tracks on a Super VCD, the total playing time is not displayed.
• You cannot use this function with VIDEO CDs or Super VCDs with PBC playback.

Playing in random order (Shuffle Play) **DVDVIDEO VCD CD**

You can have the player "shuffle" titles, chapters, or tracks. Subsequent "shuffling" may produce a different playing order.

- Press DISPLAY during playback.**
The Control Menu appears.
- Press \uparrow/\downarrow to select **SHUFFLE** (SHUFFLE), then press ENTER.**
The options for "SHUFFLE" appear.

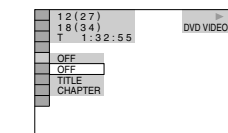

3 Press \uparrow/\downarrow to select the item to be shuffled.

- ◆ **When playing a DVD VIDEO**
• TITLE
• CHAPTER
- ◆ **When playing a VIDEO CD, or CD**
• TRACK
- ◆ **When Programme Play is activated**
• ON: shuffles titles, chapters or tracks selected in Programme Play.

4 Press ENTER.
Shuffle Play starts.

To return to normal play
Press CLEAR, or select "OFF" in step 3.

Hints
• You can set Shuffle Play while the player is stopped. After selecting the "SHUFFLE" option, press **→**. Shuffle Play starts.
• Up to 200 chapters in a disc can be played in random order when "CHAPTER" is selected.

Note
You cannot use this function with VIDEO CDs or Super VCDs with PBC playback.

Playing repeatedly (Repeat Play) **DVDVIDEO VCD CD DATA CD DATA DVD**

You can play all of the titles or tracks on a disc, or a single title, chapter, or track repeatedly.
You can use a combination of Shuffle or Programme Play modes.

- Press DISPLAY during playback.**
The Control Menu appears.
- Press \uparrow/\downarrow to select **REPEAT** (REPEAT), then press ENTER.**
The options for "REPEAT" appear.

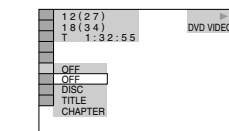

3 Press \uparrow/\downarrow to select the item to be repeated.

- ◆ **When playing a DVD VIDEO**
• DISC: repeats all of the titles.
• TITLE: repeats the current title on a disc.
• CHAPTER: repeats the current chapter.
- ◆ **When playing a DVD-VR mode disc**
• DISC: repeats all the titles of the selected type.
• TITLE: repeats the current title on a disc.
• CHAPTER: repeats the current chapter.
- ◆ **When playing a VIDEO CD, or CD**
• DISC: repeats all of the tracks.
• TRACK: repeats the current track.
- ◆ **When playing a DATA CD/DATA DVD**
• DISC: repeats all of the albums.
• ALBUM: repeats the current album.
• TRACK (MP3 audio tracks only): repeats the current track.
• FILE (DivX video files only): repeats the current file.
- ◆ **When Programme Play or Shuffle Play is activated**
• ON: repeats Programme Play or Shuffle Play.

4 Press ENTER.
Repeat Play starts.

To return to normal play
Press CLEAR, or select "OFF" in step 3.

Hint
You can set Repeat Play while the player is stopped. After selecting the "REPEAT" option, press **→**. Repeat Play starts.

Notes
• You cannot use this function with VIDEO CDs or Super VCDs with PBC playback.
• When repeating a DATA CD/DATA DVD which contains MP3 audio tracks and JPEG image files, and their playing times are not the same, the sound will not match the image.
• When "MODE (MP3, JPEG)" is set to "IMAGE (JPEG)" (page 55), you cannot select "TRACK."

Repeating a specific portion (A-B Repeat Play)

DVDvideo DVDvr VCD CD

You can play a specific portion of a title, chapter or track repeatedly. (This function is useful when you want to memorize lyrics, etc.)

- 1 Press DISPLAY during playback. The Control Menu appears.
- 2 Press \uparrow/\downarrow to select **T (TIME)** (A-B REPEAT), then press ENTER. The options for "A-B REPEAT" appear.

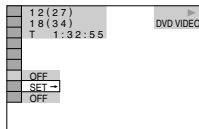

- 3 Press \uparrow/\downarrow to select "SET ->," then press ENTER. The "A-B REPEAT" setting bar appears.

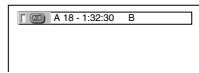

- 4 During playback, when you find the starting point (point A) of the portion to be played repeatedly, press ENTER. The starting point (point A) is set.

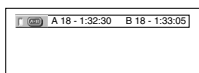

- 5 When you reach the ending point (point B), press ENTER again. The set points are displayed and the player starts repeating this specific portion.

To return to normal play
Press CLEAR, or select "OFF" in step 3.

Notes

- When you set A-B Repeat Play, the settings for Shuffle Play, Repeat Play, and Programme Play are cancelled.
- A-B Repeat Play does not work across multiple titles.
- You may not set A-B Repeat Play for contents on a DVD-RW/DVD-R (VR mode) that contains still pictures.

Searching for a Scene

Searching for a Particular Point on a Disc (Search, Scan, Slow-motion Play, Freeze Frame)

You can quickly locate a particular point on a disc by monitoring the picture or playing back slowly.

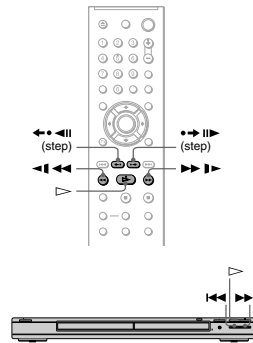

Notes

- Depending on the disc, you may not be able to do some of the operations described.
- For DATA CDs/DATA DVDs, you can search for a particular point only on MP3 audio track or DivX video file.

Locating a point quickly using the previous/next buttons (Search)

DVDvideo DVDvr VCD CD DATA CD DATA DVD

You can search for the next or previous chapter, track, or scene using \leftarrow/\rightarrow on the player. During playback, press \leftarrow/\rightarrow once briefly to go to the next or previous chapter/track/scene. Or, press and hold \leftarrow/\rightarrow to search forward or backwards, and release the button when you find the point you want to return to normal playback. (Search)

Locating a point quickly by playing a disc in fast forward or fast reverse (Scan)

DVDvideo DVDvr VCD CD DATA CD DATA DVD

Press \leftarrow/\rightarrow while playing a disc. When you find the point you want, press \leftarrow/\rightarrow to return to normal speed. Each time you press \leftarrow/\rightarrow during scan, the scan speed changes. With each press the indication changes as shown below. Actual speeds may differ between discs.

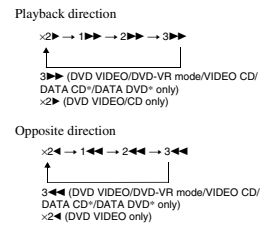

* DivX video only
The "x2" / "x2" playback speed is about twice the normal speed.
The "3" / "3" playback speed is faster than "2" / "2" and the "2" / "2" playback speed is faster than "1" / "1".

Searching for a Scene

Searching for a Scene

Watching frame by frame (Slow-motion Play)

DVDvideo DVDvr VCD DATA CD DATA DVD

Press \leftarrow/\rightarrow when the player is in pause mode. To return to normal speed, press \rightarrow . Each time you press \leftarrow/\rightarrow during Slow-motion Play, the playback speed changes. Two speeds are available. With each press the indication changes as follows:

Playback direction
 \rightarrow/\leftarrow

Opposite direction (DVD/DVD-VR mode only)
 \leftarrow/\rightarrow

The "2" / "2" playback speed is slower than "1" / "1".

Note

For DATA CDs/DATA DVDs, this function works only for DivX video files.

Playing one frame at a time (Freeze Frame)

DVDvideo DVDvr VCD DATA CD DATA DVD

When the player is in the pause mode, press \rightarrow/\leftarrow (step) to go to the next frame. Press \leftarrow/\rightarrow (step) to go to the preceding frame (DVD/DVD-VR mode only). To return to normal playback, press \rightarrow .

Notes

- You cannot search for a still picture on a DVD-RW/DVD-R in VR mode.
- For DATA CDs/DATA DVDs, this function works only for DivX video files.

Searching for a Title/Chapter/Track/Scene, etc.

DVDvideo DVDvr VCD CD DATA CD DATA DVD

You can search a DVD by title or chapter, and you can search a VIDEO CD/CD/DATA CD/DATA DVD by track, index, file, or scene. As titles and tracks are assigned unique numbers on the disc, you can select the desired one by entering its number. You can also search for a scene using the time code.

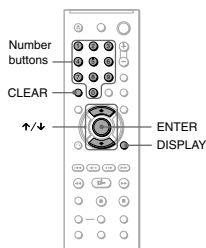

- 1 Press DISPLAY (when playing a DATA CD or DATA DVD with JPEG image files, press twice.) The Control Menu appears.

- 2 Press \uparrow/\downarrow to select a search method.

- ◆ When playing a DVD VIDEO/DVD-VR mode disc
 - TITLE
 - CHAPTER
 - TIME/TEXT
 Select "TIME/TEXT" to search for a starting point by inputting the time code.

- ◆ When playing a VIDEO CD or Super VCD without PBC playback
 - TRACK
 - INDEX

- ◆ When playing a VIDEO CD or Super VCD with PBC Playback
 - SCENE

- ◆ When playing a CD
 - TRACK

- ◆ When playing a DATA CD/DATA DVD
 - ALBUM
 - TRACK (MP3 audio tracks only)

- ◆ FILE (JPEG image files only)
- ◆ When playing a DATA CD (DivX video files)/DATA DVD (DivX video files)
 - ALBUM
 - FILE

Example: when you select \rightarrow CHAPTER
"*** (**)" is selected (** refers to a number). The number in parentheses indicates the total number of titles, chapters, tracks, indexes, scenes, albums or files.

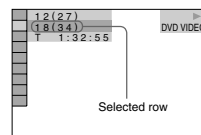

- 3 Press ENTER. "*** (**)" changes to "-- (**)."

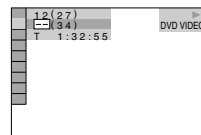

- 4 Press the number buttons to select the title, chapter, track, index, scene, etc., number you want to search.

If you make a mistake
Cancel the number by pressing CLEAR, then select another number.

- 5 Press ENTER.

The player starts playback from the selected number.

To search for a scene using the time code (DVD VIDEO/DVD-VR mode only)

- 1 In step 2, select \rightarrow TIME/TEXT. "T ***:***:***" (playing time of the current title) is selected.
- 2 Press ENTER. "T ***:***:***" changes to "T --:--:--".
- 3 Input the time code using the number buttons, then press ENTER. For example, to find the scene at 2 hours, 10 minutes and 20 seconds after the beginning, just enter "2:10:20."

Hints

- When the Control Menu display is turned off, you can search for a chapter (DVD VIDEO/DVD-VR mode), track (CD/DATA CD/DATA DVD), or file (DATA CD (DivX video)/DATA DVD (DivX video)) by pressing the number buttons and ENTER.
- You can display the first scene of titles, chapters, or tracks recorded on the disc on a screen divided into 9 sections. You can start playback directly by selecting one of the scenes. For details, see "Searching by Scene (PICTURE NAVIGATION)" (page 36).

Notes

- The title, chapter, or track number displayed is the same number recorded on the disc.
- You cannot search for a scene on a DVD+RW/DVD+R using the time code.

Searching by Scene

(PICTURE NAVIGATION) DVDVideo VCD

You can divide the screen into 9 sub-screens and find the desired scene quickly.

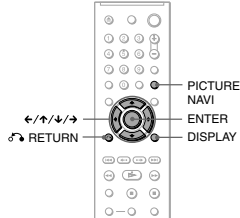

1 Press PICTURE NAVI during playback.

The following display appears.

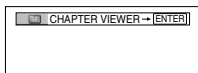

2 Press PICTURE NAVI repeatedly to select an item.

- CHAPTER VIEWER (DVD VIDEO only): displays the first scene of each chapter.
- TITLE VIEWER (DVD VIDEO only): displays the first scene of each title.
- TRACK VIEWER (VIDEO CD / Super VCD only): displays the first scene of each track.

3 Press ENTER.

The first scene of each chapter, title, or track appears as follows.

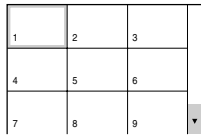

4 Press ←/↑/↓/→ to select a chapter, title, or track, and press ENTER.

Playback starts from the selected scene.

To return to normal play during setting
Press RETURN or DISPLAY.

Hint
If there are more than 9 chapters, titles, or tracks, ▼ is displayed at the bottom right of the screen. To display the additional chapters, titles, or tracks, select the bottom scenes and press ↓. To return to the previous scene, select the top scenes and press ↑.

Note
Depending on the disc, you may not be able to select some items.

Viewing Information About the Disc

Checking the Playing Time and Remaining Time

DVDVideo DVDVr VCD CD
DATA CD DATA DVD

You can check the playing time and remaining time of the current title, chapter, or track. Also, you can check the DVD/CD text, track name (MP3 audio), or file name (DivX video) recorded on the disc.

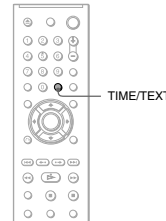

1 Press TIME/TEXT during playback.

The following display appears.

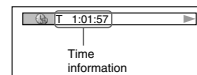

2 Press TIME/TEXT repeatedly to change the time information.

The available time information depends upon the type of disc you are playing.

◆ When playing a DVD VIDEO or DVD-VR mode disc

- T $h:m:s$ (hours: minutes: seconds) Playing time of the current title
- T- $h:m:s$ Remaining time of the current title
- C $h:m:s$ Playing time of the current chapter
- C- $h:m:s$ Remaining time of the current chapter

◆ When playing a VIDEO CD or Super VCD (with PBC functions)

- $h:m:s$ (minutes: seconds) Playing time of the current scene
- ◆ When playing a VIDEO CD (without PBC functions), or CD
- T $h:m:s$ (minutes: seconds) Playing time of the current track
- T- $h:m:s$ Remaining time of the current track
- D $h:m:s$ Playing time of the current disc
- D- $h:m:s$ Remaining time of the current disc

◆ When playing a Super VCD (without PBC functions)

- T $h:m:s$ (minutes: seconds) Playing time of the current track

◆ When playing a DATA CD (MP3 audio) or DATA DVD (MP3 audio)

- T $h:m:s$ (minutes: seconds) Playing time of the current track

◆ When playing a DATA CD (DivX video) or DATA DVD (DivX video)

- $h:m:s$ (hours: minutes: seconds) Playing time of the current file

Viewing Information About the Disc

Viewing Information About the Disc

Checking the play information of the disc

To check the DVD/CD text

Press TIME/TEXT repeatedly in step 2 to display text recorded on the DVD/CD. The DVD/CD text appears only when text is recorded in the disc. You cannot change the text. If the disc does not contain text, "NO TEXT" appears.

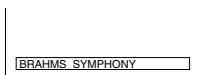

To check DATA CD (MP3 audio or DivX video)/DATA DVD (MP3 audio or DivX video) album name, etc.

By pressing TIME/TEXT while playing MP3 audio tracks or DivX video files on a DATA CD/DATA DVD, you can display the name of the album/track/file and the audio bit rate (the amount of data per second of the current audio track) on your TV screen.

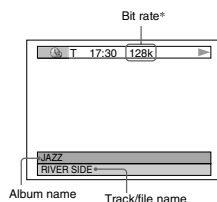

* Appears when:
- playing an MP3 audio track on a DATA CD/DATA DVD.
- playing a DivX video file that contains MP3 audio on a DATA CD/DATA DVD.

Checking the information on the front panel display

You can view the time information and text displayed on the TV screen also on the front panel display. The information on the front panel display changes as follows when you change the time information on your TV screen.

When playing a DVD VIDEO or DVD-VR mode disc

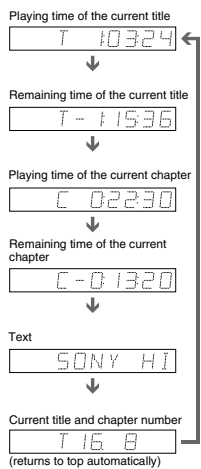

When playing a DATA CD (MP3 audio)/DATA DVD (MP3 audio)

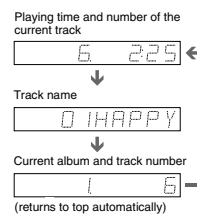

When playing a DATA CD (DivX video)/DATA DVD (DivX video)

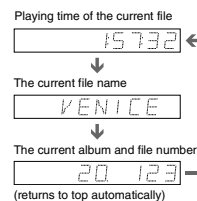

When playing a VIDEO CD (without PBC functions), or CD

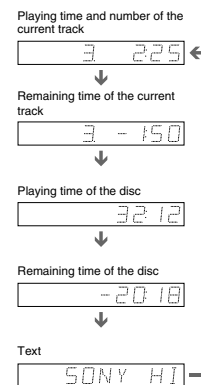

◆ **Hints**

- When playing VIDEO CDs without PBC functions, the track number and the index number are displayed after the text.
- When playing VIDEO CDs with PBC functions, the scene number or the playing time are displayed.
- Long text that does not fit in a single line will scroll across the front panel display.
- You can also check the time information and text using the Control Menu (page 12).

◆ **Notes**

- Depending on the type of disc being played, the disc text or track name may not be displayed.
- The player can only display the first level of the disc text, such as the disc name or title.
- Playing time of MP3 audio tracks and DivX video files may not be displayed correctly.
- If you play a disc containing JPEG image files only, "NO AUDIO DATA" appears when "MODE (MP3, JPEG)" is set to "AUTO." "JPEG" appears when "MODE (MP3, JPEG)" is set to "IMAGE (JPEG)" in the front panel display.

Sound Adjustments

Changing the Sound

DVD Video DVD Vn VCD CD DATA CD
DATA DVD

When playing a DVD VIDEO or DATA CD (DivX video files)/DATA DVD (DivX video files) recorded in multiple audio formats (PCM, Dolby Digital, MPEG audio, or DTS), you can change the audio format. If the DVD VIDEO is recorded with multilingual tracks, you can also change the language. With CDs, DATA CDs, DATA DVDs or VIDEO CDs, you can select the sound from either the right or left channel and listen to the sound of the selected channel through both the right and left speakers. For example, when playing a disc containing a song with the vocals on the right channel and the instruments on the left channel, you can hear the instruments from both speakers by selecting the left channel.

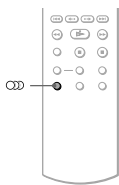

1 Press **AUDIO** during playback. The following display appears.

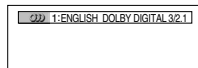

2 Press **AUDIO** repeatedly to select the desired audio signal.

◆ **When playing a DVD VIDEO**
Depending on the DVD VIDEO, the choice of language varies. When 4 digits are displayed, they indicate a language code. See "Language Code List" on page 79 to see which language the code represents. When the same language is displayed two or more times, the DVD VIDEO is recorded in multiple audio formats.

◆ **When playing a DVD-VR mode disc**
The types of sound tracks recorded on a disc are displayed. The default setting is underlined.
Example:
• 1: MAIN (main sound)
• 1: SUB (sub sound)
• 1: MAIN+SUB (main and sub sound)

◆ **When playing a VIDEO CD, CD, DATA CD (MP3 audio) or DATA DVD (MP3 audio)**
The default setting is underlined.
• STEREO: the standard stereo sound
• 1/L: the sound of the left channel (monaural)
• 2/R: the sound of the right channel (monaural)

◆ **When playing a DATA CD (DivX video), or DATA DVD (DivX video)**
Select one of the displayed audio signal formats. If "No audio data" appears, the player does not support the audio signal format contained in the disc.

◆ **When playing a Super VCD**
The default setting is underlined.
• 1: STEREO: the stereo sound of the audio track 1
• 1: 1/L: the sound of the left channel of the audio track 1 (monaural)
• 1: 2/R: the sound of the right channel of the audio track 1 (monaural)
• 2: STEREO: the stereo sound of the audio track 2
• 2: 1/L: the sound of the left channel of the audio track 2 (monaural)
• 2: 2/R: the sound of the right channel of the audio track 2 (monaural)

Notes

• While playing a Super VCD on which the audio track 2 is not recorded, no sound will come out when you select "2:STEREO," "2:1/L," or "2:2/R."

To cancel the setting
Select "OFF" in step 2.

◆ **TVS DYNAMIC THEATER**
Creates one set of LARGE virtual rear speakers and virtual subwoofer from the sound of the front speakers (L, R) without using actual rear speakers and subwoofer (shown below). This mode is effective when the distance between the front L and R speakers is short, such as with built-in speakers on a stereo TV.

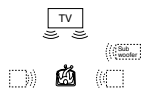

◆ **TVS DYNAMIC**
Creates one set of virtual rear speakers from the sound of the front speakers (L, R) without using actual rear speakers (shown below). This mode is effective when the distance between the front L and R speakers is short, such as with built-in speakers on a stereo TV.



◆ **TVS WIDE**
Creates five sets of virtual rear speakers from the sound of the front speakers (L, R) without using actual rear speakers (shown below). This mode is effective when the distance between the front L and R speakers is short, such as with built-in speakers on a stereo TV.

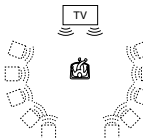

1 Press **SUR** during playback. The following display appears.

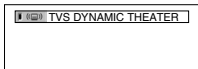

2 Press **SUR** repeatedly to select one of the TVS sounds.

- See the explanations given for each item in the following section.
- TVS DYNAMIC THEATER
 - TVS DYNAMIC
 - TVS WIDE
 - TVS NIGHT
 - TVS STANDARD

• When playing DVD-RW/DVD-R in VR mode: If you connect to an AV amplifier (receiver) using the DIGITAL OUT (COAXIAL or OPTICAL)/HDMI OUT jack and want to switch between the sound tracks, set "DOLBY DIGITAL" to "D-PCM" in "AUDIO SETUP."

Checking the audio signal format

You can check the audio signal format by pressing **AUDIO** (audio) repeatedly during playback. The format of the current audio signal (Dolby Digital, DTS, PCM, etc.) appears as shown below.

◆ When playing a DVD VIDEO

Example:
Dolby Digital 5.1 ch

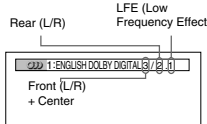

Example:
Dolby Digital 3 ch

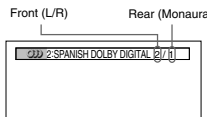

◆ When playing a DivX video file on a DATA CD or a DATA DVD

Example:
MP3 audio

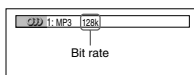

About audio signals

Audio signals recorded in a disc contain the sound elements (channels) shown below. Each channel is output from a separate speaker.

- Front (L)
- Front (R)
- Centre
- Rear (L)
- Rear (R)
- Rear (Monaural): This signal can be either the Dolby Surround Sound processed signals or the Dolby Digital sound's monaural rear audio signals.
- LFE (Low Frequency Effect) signal

Note

If "DTS" in "AUDIO SETUP" is set to "OFF," the DTS track selection option will not appear on the screen even if the disc contains DTS tracks (page 71).

Sound Adjustments

Sound Adjustments

◆ TVS NIGHT

Large sounds, such as explosions, are suppressed, but quieter sounds are unaffected. This feature is useful when you want to hear the dialogue and enjoy the surround sound effects of "TVS WIDE" at low volume.

◆ TVS STANDARD

Creates three sets of virtual rear speakers from the sound of the front speakers (L, R) without using actual rear speakers (shown below). Use this setting when you want to use TVS with 2 separate speakers.

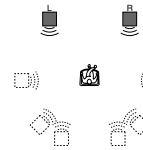

L: Front speaker (left)
R: Front speaker (right)
□: Virtual speaker

Notes

- When you select one of the TVS modes, turn off the surround setting of the connected TV or amplifier (receiver).
- Not all discs will respond to the "TVS NIGHT" function in the same way.
- When the playing signal does not contain a signal for the rear speakers, you cannot hear the TVS effect.
- When you select one of the TVS modes, the player does not output the sound of centre speaker.
- Make sure that your listening position is between and at an equal distance from your speakers, and that the speakers are located in similar surroundings.
- If you use the DIGITAL OUT (OPTICAL or COAXIAL)/HDMI OUT jack and set "DOLBY DIGITAL" to "DOLBY DIGITAL," "MPEG" to "MPEG," and "DTS" to "ON," in "AUDIO SETUP," sound will come from your speakers but it will not have the SURROUND effect.
- The TVS effects do not work when using the Fast Play or Slow Play functions, even though you can change the TVS modes.

TV Virtual Surround Settings (TVS)

DVD Video DVD Vn VCD CD DATA CD DATA DVD

When you connect a stereo TV or 2 front speakers, TVS (TV Virtual Surround) lets you enjoy surround sound effects by using sound imaging to create virtual rear speakers from the sound of the front speakers (L: left, R: right) without using actual rear speakers. TVS was developed by Sony to produce surround sound for home use using just a stereo TV. This only works when playing a multichannel Dolby audio sound track. If the player is set up to output the signal from the DIGITAL OUT (OPTICAL or COAXIAL)/HDMI OUT jack, the surround effect will only be heard when "DOLBY DIGITAL" is set to "D-PCM" and "MPEG" is set to "PCM" in "AUDIO SETUP" (page 70).

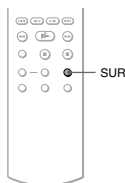

1 Press **SUR** during playback. The following display appears.

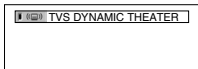

2 Press **SUR** repeatedly to select one of the TVS sounds.

- See the explanations given for each item in the following section.
- TVS DYNAMIC THEATER
 - TVS DYNAMIC
 - TVS WIDE
 - TVS NIGHT
 - TVS STANDARD

Enjoying Movies

Changing the Angles

DVDVideo

If various angles (multi-angles) for a scene are recorded on the DVD VIDEO, "ANGLE" appears in the front panel display. This means that you can change the viewing angle.

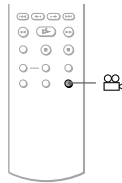

1 Press ANGLE (angle) during playback.
The number of the angle appears on the display.



2 Press ANGLE (angle) repeatedly to select an angle number.
The scene changes to the selected angle.

Note

Depending on the DVD VIDEO, you may not be able to change the angles even if multi-angles are recorded on the DVD VIDEO.

Displaying the Subtitles

DVDVideo DVDVr DATA CD DATA DVD

If subtitles are recorded on the discs, you can change the subtitles or turn them on and off whenever you want while playing the disc.

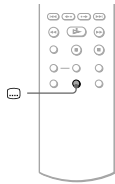

1 Press SUBTITLE (subtitle) during playback.

The following display appears.

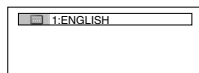

2 Press SUBTITLE (subtitle) repeatedly to select a setting.

- ◆ **When playing a DVD VIDEO**
Select the language. Depending on the DVD VIDEO, the choice of language varies. When 4 digits are displayed, they indicate a language code. See "Language Code List" on page 79 to see which language the code represents.
- ◆ **When playing a DVD-VR mode disc**
Select "ON."

- ◆ **When playing a DATA CD (DivX video), or DATA DVD (DivX video)**
Select the displayed language.

To turn off the subtitles
Select "OFF" in step 2.

Notes

- Depending on the DVD VIDEO, you may not be able to change the subtitles even if multilingual subtitles are recorded on it. You also may not be able to turn them off.
- You can change the subtitles if the DivX video file has an ".AVI" or ".DIVX" extension and contains subtitle information within the same file.
- While playing a disc with subtitles, the subtitle may disappear when you press FAST PLAY or SLOW PLAY button.

Adjusting the Playback Picture (CUSTOM PICTURE MODE)

DVDVideo DVDVr VCD DATA CD DATA DVD

You can adjust the video signal of the DVD, VIDEO CD, DATA CD/DATA DVD in JPEG format, or DATA CD/DATA DVD containing DivX video files from the player to obtain the picture quality you want. Choose the setting that best suits the programme you are watching. When you select "MEMORY," you can make further adjustments to each element of the picture (colour, brightness, etc.).

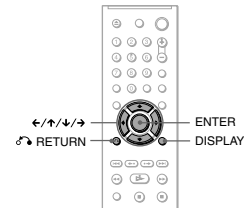

1 Press DISPLAY twice during playback.

The Control Menu appears.

2 Press UP/DOWN to select MEMORY (CUSTOM PICTURE MODE), then press ENTER.

The options for "CUSTOM PICTURE MODE" appear.

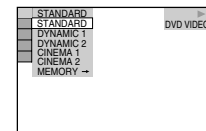

Enjoying Movies

Enjoying Movies

3 Press UP/DOWN to select the setting you want.

- The default setting is underlined.
- **STANDARD:** displays a standard picture.
- **DYNAMIC 1:** produces a bold dynamic picture by increasing the picture contrast and the colour intensity.
- **DYNAMIC 2:** produces a more dynamic picture than DYNAMIC 1 by further increasing the picture contrast and colour intensity.
- **CINEMA 1:** enhances details in dark areas by increasing the black level.
- **CINEMA 2:** white colours become brighter and black colours become richer, and the colour contrast is increased.
- **MEMORY:** adjusts the picture in greater detail.

4 Press ENTER.

The selected setting takes effect.

Hint

When you watch a movie, "CINEMA 1" or "CINEMA 2" is recommended.

Adjusting the picture items in "MEMORY"

You can adjust each element of the picture individually.

- **PICTURE:** changes the contrast
- **BRIGHTNESS:** changes the overall brightness
- **COLOR:** makes the colours deeper or lighter
- **HUE:** changes the colour balance

1 In step 3 of "Adjusting the Playback Picture," select "MEMORY" and press ENTER.
The "PICTURE" adjustment bar appears.



2 Press LEFT/RIGHT to adjust the picture contrast.

To go to the next or previous picture item without saving the current setting, press UP/DOWN.

3 Press ENTER.

The adjustment is saved, and "BRIGHTNESS" adjustment bar appears.

4 Repeat step 2 and 3 to adjust "BRIGHTNESS," "COLOR," and "HUE."

To turn off the display

Press RETURN, or DISPLAY.

Note

The "BRIGHTNESS" setting is not effective if you connect the player via the LINE OUT (VIDEO), S VIDEO OUT, or LINE (RGB)-TV jack, and select "PROGRESSIVE AUTO" or "PROGRESSIVE VIDEO" by using the PROGRESSIVE button on the front panel.

Sharpening the Picture (SHARPNESS)

DVDVideo DVDVr VCD DATA CD DATA DVD

You can enhance the outlines of images to produce a sharper picture.

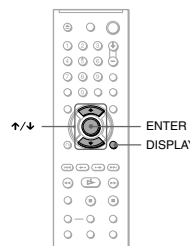

1 Press DISPLAY twice during playback.

The Control Menu appears.

2 Press UP/DOWN to select SHARPNESS (SHARPNESS), then press ENTER.

The options for "SHARPNESS" appear.

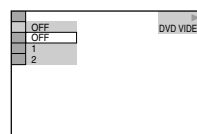

3 Press UP/DOWN to select a level.

- 1: enhances the outline.
- 2: enhances the outline more than 1.

4 Press ENTER.

The selected setting takes effect.

To cancel the "SHARPNESS" setting

Select "OFF" in step 3.

Note

This setting is not effective if you connect the player via the LINE OUT (VIDEO), S VIDEO OUT, or LINE (RGB)-TV jack, and select "PROGRESSIVE AUTO" or "PROGRESSIVE VIDEO" by using the PROGRESSIVE button on the front panel.

Adjusting the Picture Quality (BNR, MNR)

DVD Video DVD-VR VCD DATA CD DATA DVD

You can adjust the picture quality by "BNR" (Block Noise Reduction) or "MNR" (Mosquito Noise Reduction)

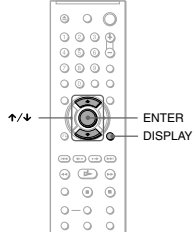

Adjusting the BNR

The "BNR" function adjusts the picture quality by reducing the "block noise" or mosaic like patterns that appear on your TV screen.

1 Press DISPLAY twice during playback.

The Control Menu appears.

2 Press \uparrow/\downarrow to select [BNR] (BNR), then press ENTER.

The options for "BNR" appear.

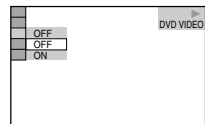

48



4 Press \rightarrow repeatedly to adjust the delay.

Each time you press \rightarrow , the delay is adjusted by 10 milliseconds.

5 Press ENTER.

The selected setting takes effect.

To reset the "AV SYNC" setting
Press CLEAR in step 4.

Notes

- This function is not effective if you use the DIGITAL OUT (OPTICAL or COAXIAL) jack, and set "DOLBY DIGITAL," "MPEG" or "DTS" in AUDIO SETUP to "DOLBY DIGITAL," "MPEG" or "ON" respectively (page 70).
- This function is not effective if you connect a Dolby Digital or DTS-compliant device via the HDMI OUT jack, and set "DOLBY DIGITAL," "MPEG" or "DTS" in AUDIO SETUP to "DOLBY DIGITAL," "MPEG" or "ON" respectively (page 70).
- For DATA CDs/DATA DVDs, this function works only for DivX video files.

3 Press \uparrow/\downarrow to select the setting.

- OFF: To cancel the "BNR" effect.
- ON: To turn on the "BNR" effect.

4 Press ENTER.

The disc plays with the setting you selected.

To cancel the "BNR" setting
Select "OFF" in step 3.

To turn off the Control Menu

Press DISPLAY repeatedly until the Control Menu is turned off.

Notes

- If the outlines of the images on your screen should become blurred, set "BNR" to "OFF."
- Depending on the disc or the scene being played, there may be no "BNR" effect, or it may be hard to discern.

Adjusting the MNR

The "MNR" function adjusts the picture quality by reducing the faint noise appearing around the outlines of the images. The noise reduction effects are automatically adjusted within each setting range according to the video bit rate and other factors.

1 Press DISPLAY twice during playback.

The Control Menu appears.

2 Press \uparrow/\downarrow to select [MNR] (MNR), then press ENTER.

The options for "MNR" appear.

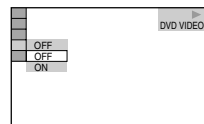

3 Press \uparrow/\downarrow to select the setting.

- OFF: To cancel the "MNR" effect.
- ON: To turn on the "MNR" effect.

4 Press ENTER.

The disc plays with the setting you selected.

To cancel the "MNR" setting

Select "OFF" in step 3.

To turn off the Control Menu

Press DISPLAY repeatedly until the Control Menu is turned off.

Notes

- If the outlines of the images on your screen should become blurred, set "MNR" to "OFF."
- Depending on the disc or the scene being played, there may be no "MNR" effect, or it may be hard to discern.

Adjusting the Delay Between the Picture and Sound (AV SYNC)

DVD Video DVD-VR VCD DATA CD DATA DVD

When the sound does not match the pictures on the screen, you can adjust the delay between the picture and sound.

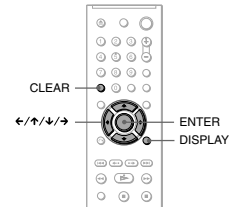

1 Press DISPLAY twice during playback.

The Control Menu appears.

2 Press \uparrow/\downarrow to select [AV SYNC] (AV SYNC), then press ENTER.

The following display appears.

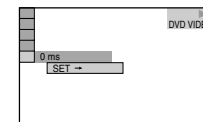

3 Press \rightarrow to select "SET \rightarrow ", then press ENTER.

The "AV SYNC" adjustment bar appears.

Enjoying Movies

\rightarrow continued 49

Enjoying MP3 Audio and JPEG Images

About MP3 Audio Tracks and JPEG Image Files

MP3 is audio compression technology that satisfies the ISO/IEC MPEG regulations. JPEG is image compression technology. You can play DATA CDs/DATA DVD that contain MP3 audio tracks or JPEG image files.

DATA CDs/DATA DVDs that the player can play

You can play back DATA CDs (CD-ROMs/CD-Rs/CD-RWs) or DATA DVDs (DVD-ROMs/DVD+RWs/DVD+Rs/DVD-RWs/DVD-Rs) recorded in MP3 (MPEG-1 Audio Layer III) and JPEG format. However, the discs must be recorded according to ISO 9660 Level 1/Level 2 or Joliet format and DATA DVDs of Universal Disk Format (UDF) for the player to recognize the tracks (or files). Refer to the instructions supplied with the CD-R/CD-RW drives and the recording software (not supplied) for details on the recording format.

Note

The player may not be able to play some DATA CDs/DATA DVDs created in the Packet Write format.

MP3 audio track or JPEG image file that the player can play

The player can play the following tracks and files:

- MP3 audio tracks with the extension ".MP3"
- JPEG image files with the extension ".JPEG" or ".JPG."
- JPEG image files that conform to the DCF* image file format.

* "Design rule for Camera File system": Image standards for digital cameras regulated by JEITA (Japan Electronics and Information Technology Industries Association).

Notes

- The player will play any data with the extension ".MP3," ".JPG," or ".JPEG," even if they are not in MP3 or JPEG format. Playing these data may generate a loud noise which could damage your speaker system.
- The player does not conform to audio tracks in mp3PRO format.
- Some JPEG files cannot be played.
- You cannot play MP3 audio tracks/JPEG image files in DATA CDs/DATA DVDs that contain DivX video files.

About playback order of albums, tracks, and files

Albums play in the following order:

◆ Structure of disc contents

Tree 1 Tree 2 Tree 3 Tree 4 Tree 5

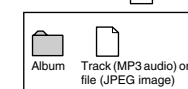
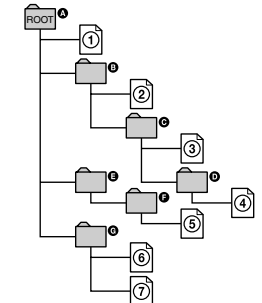

Enjoying MP3 Audio and JPEG Images

\rightarrow continued 51

50

When you insert a DATA CD/DATA DVD and press \triangleright , the numbered tracks (or files) are played sequentially, from ① through ⑦. Any sub-albums/tracks (or files) contained within a currently selected album take priority over the next album in the same tree. (Example: ② contains ③ so ④ is played before ⑤.)

When you press MENU and the list of album names appears (page 53), the album names are arranged in the following order: ① → ② → ③ → ④ → ⑤ → ⑥. Albums that do not contain tracks (or files) (such as album ⑦) do not appear in the list.

Hints

- If you add numbers (01, 02, 03, etc.) to the front of the track/file names when you store the tracks (or files) in a disc, the tracks and files will be played in that order.
- Since a disc with many trees takes longer to start playback, it is recommended that you create albums with no more than two trees.

Notes

- Depending on the software you use to create the DATA CD/DATA DVD, the playback order may differ from the above illustration.
- The playback order above may not be applicable if there are more than 200 albums and 300 tracks/files in each album.
- The player can recognize up to 200 albums (the player will count just albums, including albums that do not contain MP3 audio tracks and JPEG image files). The player will not play any albums beyond the 200th album.
- Proceeding to the next or another album may take some time.

Playing MP3 Audio Tracks or JPEG Image Files DATA CD DATA DVD

You can play MP3 audio tracks and JPEG image files on DATA CDs (CD-ROMs/CD-Rs/CD-RWs) or DATA DVDs (DVD-ROMs/DVD+RWS/DVD+R/DVD-RWS/DVD-Rs).

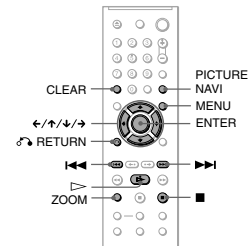

Hint

You can view the disc information while playing MP3 audio tracks (page 37).

Notes

- DATA CDs recorded in KODAK Picture CD format automatically start playing when inserted.
- If no MP3 audio track or JPEG image file is recorded on the DATA CD/DATA DVD, "No audio data" or "No image data" appears on the screen.

Selecting an album

- 1 Press MENU. The list of albums on the disc appears. When an album is being played, its title is shaded.



- 2 Press \uparrow/\downarrow to select the album you want to play.
- 3 Press \triangleright . Playback starts from the selected album. To select MP3 audio tracks, see "Selecting an MP3 audio track" (page 53). To select JPEG image files, see "Selecting a JPEG image file" (page 54).

To stop playback

Press \blacksquare .

To go to the next or previous page

Press \rightarrow or \leftarrow .

To turn on or off the display

Press MENU repeatedly.

Hint

Of the selected album, you can select to play only the MP3 audio tracks, JPEG image files, or both, by setting "MODE (MP3, JPEG)" (page 55).

Selecting an MP3 audio track

- 1 After step 2 of "Selecting an album," press ENTER. The list of tracks in the album appears.

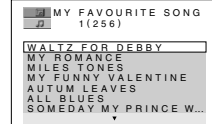

- 2 Press \uparrow/\downarrow to select a track, and press ENTER. Playback starts from the selected track.

To stop playback

Press \blacksquare .

To go to the next or previous page

Press \rightarrow or \leftarrow .

To return to the previous display

Press \leftarrow RETURN.

To go to the next or previous MP3 audio track

Press \triangleright or \triangleleft during playback. You can select the first track of the next album by pressing \triangleright during playback of the last track of the current album.

Note that you cannot return to the previous album by using \triangleleft , and that you need to select the previous album from the album list.

Enjoying MP3 Audio and JPEG Images

Selecting a JPEG image file

- 1 After step 2 of "Selecting an album," press PICTURE NAVI. The image files in the album appear in 16 sub-screens. A scroll box is displayed on the right.

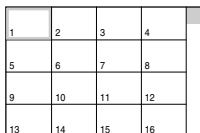

To display the additional image, select the bottom images and press \downarrow . To return to the previous image, select the top images and press \uparrow .

- 2 Press \leftarrow/\rightarrow to select the image you want to view, and press ENTER. The selected image appears. Example

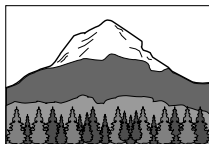

To go to the next or previous JPEG image file

Press \leftarrow or \rightarrow during playback. You can select the first file of the next album by pressing \rightarrow during playback of the last file of the current album. Note that you cannot return to the previous album by using \leftarrow , and that you need to select the previous album from the album list.

To rotate a JPEG image

Press \uparrow/\downarrow while viewing the image. Each time you press \uparrow , the image rotates counterclockwise by 90 degrees. To return to normal view, press CLEAR. Note that the view also returns to normal if you press \leftarrow/\rightarrow to go to the next or previous image. Example: when \uparrow is pressed once.

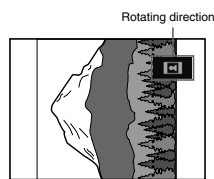

To magnify a JPEG image (ZOOM)

Press ZOOM while viewing the image. You can enlarge the image up to four times the original size, and scroll using \leftarrow/\rightarrow . To return to normal view, press CLEAR.

- ◆When pressed once (x2) The image enlarges twice the original size.
- ◆When pressed twice (x4) The image enlarges four times the original size.

To stop viewing the JPEG image

Press \blacksquare .

Hints

- While viewing JPEG image files, you can set options such as "INTERVAL" (page 56), "EFFECT" (page 56), and "SHARPNESS" (page 47).
- You can view JPEG images files without MP3 audio by setting "MODE (MP3, JPEG)" to "IMAGE (JPEG)" (page 55).
- The date the picture was taken is displayed beside "DATE" in the Control Menu (page 12). Note that no date may appear depending on the digital camera.

Note

PICTURE NAVI does not work if "AUDIO (MP3)" is selected in "MODE (MP3, JPEG)" (page 55).

Enjoying JPEG Images as a Slide Show

DATA CD DATA DVD

You can play JPEG image files on a DATA CD or DATA DVD successively as a slide show.

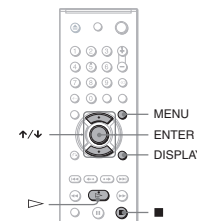

- 1 Press MENU. The list of albums on the DATA CD/DATA DVD appears.



- 2 Press \uparrow/\downarrow to select an album.
- 3 Press \triangleright . The JPEG images in the selected album start playing as a slide show.

To stop playback

Press \blacksquare .

Notes

- The slide show stops when \uparrow/\downarrow or ZOOM is pressed. To resume the slide show, press \triangleright .
- This function does not work if "MODE (MP3, JPEG)" is set to "AUDIO (MP3)" (page 55).

Viewing a slide show with sound (MODE (MP3, JPEG))

When JPEG image files and MP3 audio tracks are placed in the same album, you can enjoy a slide show with sound.

- 1 Press DISPLAY during stop mode. The Control Menu appears.
- 2 Press \uparrow/\downarrow to select AUTO (MODE (MP3, JPEG)), and press ENTER. The options for "MODE (MP3, JPEG)" appear.

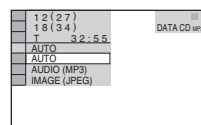

- 3 Press \uparrow/\downarrow to select "AUDIO" (default), and press ENTER.

- AUTO: plays both the JPEG image files and MP3 audio tracks in the same album as a slide show.
- AUDIO (MP3): plays only MP3 audio tracks continuously.
- IMAGE (JPEG): plays only JPEG image files continuously.

- 4 Press MENU. The list of albums on the DATA CD/DATA DVD appears.



- 5 Press \uparrow/\downarrow to select the album that contains both the MP3 audio tracks and JPEG images you want to play.
- 6 Press \triangleright . A slide show starts with sound.

Enjoying MP3 Audio and JPEG Images

Hints

- To repeat both MP3 audio tracks and JPEG image files in a single album, repeat the same MP3 audio track or album when "MODE(MP3, JPEG)" is set to "AUTO." See "Playing repeatedly (Repeat Play)" (page 31) to repeat the track or album.
- The player recognizes a maximum of 200 albums regardless of the selected mode. Of each album, the player recognizes up to 300 MP3 audio tracks and 300 JPEG image files when "AUTO" is selected, 600 MP3 audio tracks when "AUDIO (MP3)" is selected, 600 JPEG image files when "IMAGE (JPEG)" is selected.

Notes

- This function does not work if the MP3 audio tracks and JPEG image files are not placed in the same album.
- If playing time of JPEG image or MP3 audio is longer than the other, the longer one continues without sound or image.
- If you play large MP3 track data and JPEG image data at the same time, the sound may skip. It is recommended that you set the MP3 bit rate to 128 kbps or lower when creating the file. If the sound still skips, then reduce the size of the JPEG file.

Setting the pace for a slide show (INTERVAL)

You can set the time the slides are displayed on the screen.

- Press **DISPLAY** twice while viewing a JPEG image or when the player is in stop mode. The Control Menu appears.

- Press **↑/↓** to select **INTERVAL**, then press **ENTER**. The options for "INTERVAL" appear.

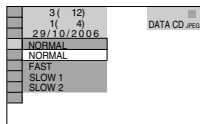

- Press **↑/↓** to select a setting. The default setting is underlined.
 - NORMAL**: sets the duration to between 6 to 9 seconds.
 - FAST**: sets a duration shorter than NORMAL.

- SLOW 1**: sets a duration longer than NORMAL.
- SLOW 2**: sets a duration longer than SLOW 1.

- Press **ENTER**.

Note

Some JPEG files, especially progressive JPEG files or JPEG files of 3,000,000 pixels or more, may take longer to display than others, which may make the duration seem longer than the setting you selected.

Selecting the slides' appearance (EFFECT)

You can select the way the slides are displayed during a slide show.

- Press **DISPLAY** twice while viewing a JPEG image or when the player is in stop mode.

- Press **↑/↓** to select **EFFECT**, then press **ENTER**. The options for "EFFECT" appear.

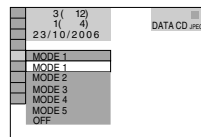

- Press **↑/↓** to select a setting. The default setting is underlined.
 - MODE 1**: the image sweeps in from top to bottom.
 - MODE 2**: the image sweeps in from left to right.
 - MODE 3**: the image stretches out from the centre of the screen.
 - MODE 4**: the images randomly cycle through the effects.
 - MODE 5**: the next image slides over the previous image.
 - OFF**: turns off this function.

- Press **ENTER**.

Playing DivX Video Files

DATA CD DATA DVD

You can play DivX video files on DATA CDs (CD-ROMs/CD-Rs/CD-RWs) and DATA DVDs (DVD-ROMs/DVD+Rws/DVD+R/DVD-Rs/DVD-RWs/DVD-Rs).

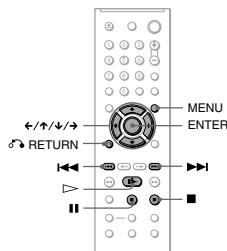

Hint

You can view the disc information while playing a DivX video file (page 37).

Notes

- If there are no DivX video files recorded on the DATA CD/DATA DVD, a message appears to indicate that the disc is not playable.
- Depending on the DivX video file, the picture may pause or be unclear. In which case, it is recommended that you create the file at a lower bit rate. If the sound is still noisy, MP3 is the recommended audio format. Note, however, this player does not conform to WMA (Windows Media Audio) format.
- Because of the compression technology used for DivX video files, it may take some time after you press **▶** (play) for the picture to appear.
- Depending on the DivX video file, the sound may not match the pictures on the screen.

Selecting an album

- Press **MENU**. A list of albums on the disc appears. Only albums that contain DivX video files are listed.

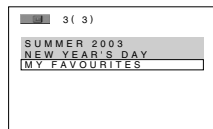

- Press **↑/↓** to select the album you want to play.

- Press **▶**. Playback starts from the selected album. To select DivX video files, see "Selecting a DivX video file" (page 59).

To stop playback

Press **■**.

To go to the next or previous page

Press **←** or **→**.

To turn the display on or off

Press **MENU** repeatedly.

Enjoying DivX® Videos

About DivX Video Files

DivX® is a video file compression technology, developed by DivX, Inc. This product is an official DivX® Certified product. You can play DATA CDs and DATA DVDs that contain DivX video files.

DATA CDs and DATA DVDs that the player can play

Playback of DATA CDs (CD-ROMs/CD-Rs/CD-RWs) and DATA DVDs (DVD-ROMs/DVD+Rws/DVD+R/DVD-Rs) on this player is subject to certain conditions: –With DATA CDs/DATA DVDs that contain DivX video files in addition to MP3 audio tracks or JPEG image files, the player plays only the DivX video files. However, this player only plays DATA CDs whose logical format is ISO 9660 Level 1/Level 2 or Joliet, and DATA DVDs of Universal Disk Format (UDF). Refer to the instructions supplied with the disc drives and the recording software (not supplied) for details on the recording format.

About playback order of data on DATA CDs or DATA DVDs

See "About playback order of albums, tracks, and files" (page 51). Note that the playback order may not be applicable, depending on the software used for creating the DivX video file, or if there are more than 200 albums and 600 DivX video files in each album.

Note

The player may not be able to play some DATA CDs/DATA DVDs created in the Packet Write format.

DivX video files that the player can play

The player can play data that is recorded in DivX format, and which has the extension ".AVI" or ".DIVX." The player will not play files with the extension ".AVI" or ".DIVX" if they do not contain a DivX video.

Hint

For details about playable MP3 audio tracks or JPEG image files on DATA CDs/DATA DVDs, see "DATA CDs/DATA DVDs that the player can play" (page 51).

Notes

- The player may not play a DivX video file when the file has been combined from two or more DivX video files.
- The player cannot play a DivX video file of size more than 720 (width) x 576 (height)/2 GB.
- Depending on the DivX video file, the picture may be unclear or the sound may skip.
- The player cannot play some DivX video files that are longer than 3 hours.

Selecting a DivX video file

- After step 2 of "Selecting an album," press **ENTER**. The list of files in the album appears.

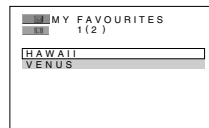

- Press **↑/↓** to select a file, and press **ENTER**. The selected file starts playing.

To stop playback

Press **■**.

To go to the next or previous page

Press **←** or **→**.

To return to the previous display

Press **↵** RETURN.

To go to the next or previous DivX video file without turning on the above file list

You can select the next or previous DivX video file in the same album by pressing **▶▶** or **◀◀**.

You can also select the first file of the next album by pressing **▶▶▶** during playback of the last file of the current album. Note that you cannot return to the previous album by using **◀◀◀**. To return to the previous album, select it from the album list.

Hint

If the number of viewing times is preset, you can play the DivX video files as many times as the preset number. The following occurrences are counted: – when the player is turned off. This includes when the player is automatically turned off by the Auto Power Off function. Press **■** instead of **■** when you want to stop viewing – when the disc tray is opened. – when another file is played.

Using Various Additional Functions

Locking Discs (CUSTOM PARENTAL CONTROL, PARENTAL CONTROL)

You can set two kinds of playback restrictions for a disc.

- Custom Parental Control
- Parental Control

Playback of some DVD VIDEOS can be limited according to a predetermined level such as the age of the users. Scenes may be blocked or replaced with different scenes. The same password is used for both Parental Control and Custom Parental Control.

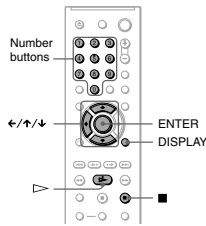

Custom Parental Control

You can set the same Custom Parental Control password for up to 40 discs. When you set the 41st-disc, the first disc is cancelled.

- 1 Insert the disc you want to lock. If the disc is playing, press ■ to stop playback.
- 2 Press DISPLAY while the player is in stop mode. The Control Menu appears.

The area is selected. When you select "OTHERS →," select and enter a standard code in the table on page 79 using the number buttons.

- 7 Press ↑/↓ to select "LEVEL," then press ENTER. The selection items for "LEVEL" are displayed.

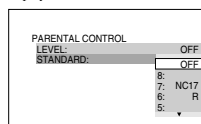

- 8 Select the level you want using ↑/↓, then press ENTER. Parental Control setting is complete.

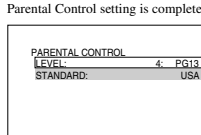

The lower the value, the stricter the limitation.

To turn off the Parental Control function Set "LEVEL" to "OFF" in step 8.

To play a disc for which Parental Control is set

- 1 Insert the disc and press ▷. The display for entering your password appears.
- 2 Enter your 4-digit password using the number buttons, then press ENTER. The player starts playback.

Hint
If you forget your password, remove the disc and repeat steps 1 to 3 of "Parental Control (limited playback)." When you are asked to enter your password, enter "199703" using the number buttons, then press ENTER. The display will ask you to enter a new 4-digit password. After you enter a new 4-digit password, replace the disc in the player and press ▷. When the display for entering your password appears, enter your new password.

- 3 Press ↑/↓ to select (PARENTAL CONTROL), then press ENTER. The options for "PARENTAL CONTROL" appear.

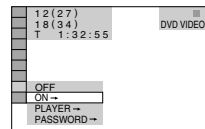

- 4 Press ↑/↓ to select "ON →," then press ENTER. If you have not entered a password The display for registering a new password appears.



Enter a 4-digit password using the number buttons, then press ENTER. The display for confirming the password appears.

When you have already registered a password The display for entering the password appears.

- 5 Enter or re-enter your 4-digit password using the number buttons, then press ENTER. "Custom parental control is set." appears and then the screen returns to the Control Menu.

To turn off the Custom Parental Control function

- 1 Follow steps 1 to 3 of "Custom Parental Control."
- 2 Press ↑/↓ to select "OFF →," then press ENTER.
- 3 Enter your 4-digit password using the number buttons, then press ENTER.

Notes

- When you play discs which do not have the Parental Control function, playback cannot be limited on this player.
- Depending on the disc, you may be asked to change the parental control level while playing the disc. In this case, enter your password, then change the level. If the Resume Play mode is cancelled, the level returns to the previous level.

Changing the password

- 1 Press DISPLAY while the player is in stop mode. The Control Menu appears.
- 2 Press ↑/↓ to select (PARENTAL CONTROL), then press ENTER. The options for "PARENTAL CONTROL" appear.
- 3 Press ↑/↓ to select "PASSWORD →," then press ENTER. The display for entering the password appears.
- 4 Enter your 4-digit password using the number buttons, then press ENTER.
- 5 Enter a new 4-digit password using the number buttons, then press ENTER.
- 6 To confirm your password, re-enter it using the number buttons, then press ENTER.

If you make a mistake entering your password Press ← before you press ENTER and input the correct number.

To play a disc for which Custom Parental Control is set

- 1 Insert the disc for which Custom Parental Control is set. The "CUSTOM PARENTAL CONTROL" display appears.

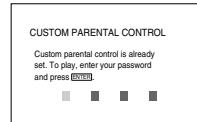

- 2 Enter your 4-digit password using the number buttons, then press ENTER. The player is ready for playback.

Hint
If you forget your password, enter the 6-digit number "199703" using the number buttons when the "CUSTOM PARENTAL CONTROL" display asks you for your password, then press ENTER. The display will ask you to enter a new 4-digit password.

Parental Control (limited playback)

Playback of some DVD VIDEOS can be limited according to a predetermined level such as the age of the users. The "PARENTAL CONTROL" function allows you to set a playback limitation level.

- 1 Press DISPLAY while the player is in stop mode. The Control Menu appears.
- 2 Press ↑/↓ to select (PARENTAL CONTROL), then press ENTER. The options for "PARENTAL CONTROL" appear.

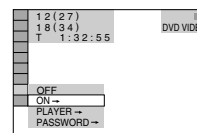

Controlling Your TV with the Supplied Remote

You can control the sound level, input source, and power switch of your Sony TV with the supplied remote.

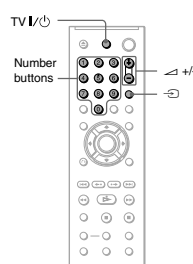

You can control your TV using the buttons below.

| By pressing | You can |
|----------------|--|
| TV I/O | Turn the TV on or off |
| ⏪ (volume) +/- | Adjust the volume of the TV |
| ⏮ (TV/video) | Switch the TV's input source between the TV and other input sources. |

Note
Depending on the connected unit, you may not be able to control your TV using all or some of the buttons on the supplied remote.

- 3 Press ↑/↓ to select "PLAYER →," then press ENTER.

◆ If you have not entered a password The display for registering a new password appears.



Enter a 4-digit password using the number buttons, then press ENTER. The display for confirming the password appears.

◆ When you have already registered a password The display for entering the password appears.

- 4 Enter or re-enter your 4-digit password using the number buttons, then press ENTER. The display for setting the playback limitation level appears.

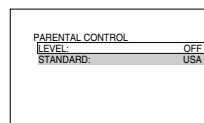

- 5 Press ↑/↓ to select "STANDARD," then press ENTER. The selection items for "STANDARD" are displayed.

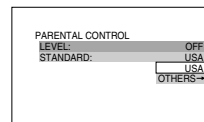

- 6 Press ↑/↓ to select a geographic area as the playback limitation level, then press ENTER.

Using Various Additional Functions

Using Various Additional Functions

Controlling other TVs with the remote

You can control the sound level, input source, and power switch of non-Sony TVs as well. If your TV is listed in the table below, set the appropriate manufacturer's code.

- 1 While holding down TV I/O, press the number buttons to select your TV's manufacturer's code (see the table below).
- 2 Release TV I/O.

Code numbers of controllable TVs
If more than one code number is listed, try entering them one at a time until you find the one that works with your TV.

| Manufacturer | Code number |
|--------------|--------------|
| Sony | 01 (default) |
| Aiwa | 01 (default) |
| Grundig | 11 |
| Hitachi | 24 |
| JVC | 33 |
| LG | 06 |
| Loewe | 06 |
| Panasonic | 17, 49 |
| Philips | 06, 08 |
| Samsung | 06, 71 |
| Sanyo | 25 |
| Sharp | 29 |
| Thomson | 43 |
| Toshiba | 38 |

Notes
• When you replace the batteries of the remote, the code number you have set may be reset to the default setting. Set the appropriate code number again.
• Depending on the connected unit, you may not be able to control your TV using all or some of the buttons on the supplied remote.

Settings and Adjustments

Using the Setup Display

By using the Setup Display, you can make various adjustments to items such as picture and sound. You can also set a language for the subtitles and the Setup Display, among other things.

For details on each Setup Display item, see pages from 65 to 71.

Note

Playback settings stored in the disc take priority over the Setup Display settings and not all of the functions described may work.

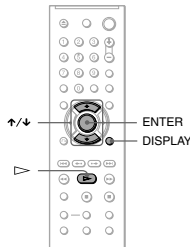

1 Press DISPLAY when the player is in stop mode. The Control Menu appears.

2 Press \uparrow/\downarrow to select **SETUP**, then press ENTER. The options for "SETUP" appear.

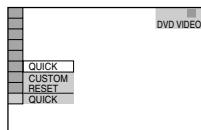

3 Press \uparrow/\downarrow to select "CUSTOM," then press ENTER. The Setup Display appears.

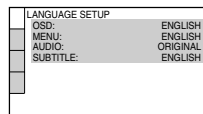

4 Press \uparrow/\downarrow to select the setup item from the displayed list: "LANGUAGE SETUP," "SCREEN SETUP," "CUSTOM SETUP," or "AUDIO SETUP." Then press ENTER. The Setup item is selected. Example: "SCREEN SETUP"

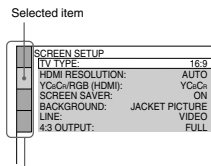

5 Press \uparrow/\downarrow to select an item, then press ENTER. The options for the selected item appear. Example: "TV TYPE"

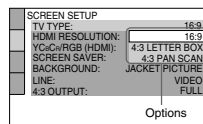

Settings for the Display (SCREEN SETUP)

Choose settings according to the TV to be connected.

Select "SCREEN SETUP" in the Setup Display. To use the display, see "Using the Setup Display" (page 64). The default settings are underlined.

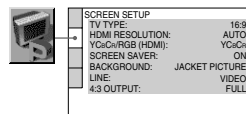

TV TYPE

Selects the aspect ratio of the connected TV (4:3 standard or wide).

| | |
|----------------|---|
| 16:9 | Select this when you connect a wide-screen TV or a TV with a wide mode function. |
| 4:3 LETTER BOX | Select this when you connect a 4:3 screen TV. Displays a wide picture with bands on the upper and lower portions of the screen. |
| 4:3 PAN SCAN | Select this when you connect a 4:3 screen TV. Automatically displays the wide picture on the entire screen and cuts off the portions that do not fit. |

16:9



4:3 LETTER BOX



4:3 PAN SCAN



Note

Depending on the DVD, "4:3 LETTER BOX" may be selected automatically instead of "4:3 PAN SCAN" or vice versa.

HDMI RESOLUTION

Selects the type of video signals output from the HDMI OUT jack. When you select AUTO (default), the player outputs video signals of the highest resolution acceptable for your TV. If the picture is not clear, natural or to your satisfaction, try another option that suits the disc and your TV/projector, etc. For details, refer also to the instruction manual supplied with the TV/projector, etc.

| | |
|--------------|---|
| AUTO | Normally, select this. |
| 1920x1080i | Sends 1920x1080i video signals. |
| 1280x720p | Sends 1280x720p video signals. |
| 720x480/576p | Sends 720x480p or 720x576p video signals. |

Notes

- Even when a setting other than "AUTO" is selected and the connected TV cannot accept the resolution, the player automatically adjusts the video signals that are suitable for the TV.
- When the HDMI indicator on the front panel lights up, images from the S VIDEO OUT and LINE OUT (VIDEO) jacks are enlarged vertically. (Except when 720x480/576p is selected)

YCaCb (HDMI)

Selects the type of HDMI signal output from HDMI OUT jack.

| | |
|-------|------------------------|
| YCaCb | Outputs YCaCb signals. |
| RGB | Outputs RGB signals. |

Notes

- If the playback picture becomes distorted, set "YCaCb" to "RGB."
- If the HDMI OUT jack is connected to equipment with a DVI jack, "RGB" signals will be automatically output even when you select "YCaCb."

6 Press \uparrow/\downarrow to select a setting, then press ENTER. The setting is selected and setup is complete. Example: "4:3 PAN SCAN"

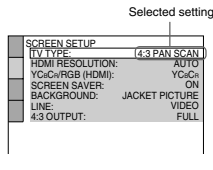

To enter the Quick Setup mode

Select "QUICK" in step 3. Follow from step 5 of the Quick Setup explanation to make basic adjustments (page 22).

To reset all of the "SETUP" settings

- 1 Select "RESET" in step 3 and press ENTER.
- 2 Select "YES" using \uparrow/\downarrow . You can also quit the process and return to the Control Menu by selecting "NO" here.
- 3 Press ENTER. All the settings explained on pages 65 to 69 return to the default settings. Do not press \uparrow/\downarrow while resetting the player, which takes a few seconds to complete.

Setting the Display or Sound Track Language (LANGUAGE SETUP)

"LANGUAGE SETUP" allows you to set various languages for the on-screen display or sound track.

Select "LANGUAGE SETUP" in the Setup Display. To use the display, see "Using the Setup Display" (page 64).

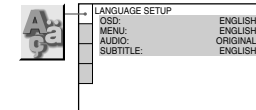

OSD (On-Screen Display)

Switches the display language on the screen.

MENU (DVD VIDEO only)

You can select the desired language for the disc's menu.

AUDIO (DVD VIDEO only)

Switches the language of the sound track. When you select "ORIGINAL," the language given priority in the disc is selected.

SUBTITLE (DVD VIDEO only)

Switches the language of the subtitle recorded on the DVD VIDEO. When you select "AUDIO FOLLOW," the language for the subtitles changes according to the language you selected for the sound track.

Hint

If you select "OTHERS" in "MENU," "SUBTITLE," or "AUDIO," select and enter a language code from "Language Code List" on page 79 using the number buttons.

Note

If you select a language in "MENU," "SUBTITLE," or "AUDIO" that is not recorded on a DVD VIDEO, one of the recorded languages will be automatically selected.

SCREEN SAVER

The screen saver image appears when you leave the player in pause or stop mode for 15 minutes, or when you play a CD, or DATA CD (MP3 audio)/DATA DVD (MP3 audio) for more than 15 minutes. The screen saver will help prevent your display device from becoming damaged (ghosting). Press \triangleright to turn off the screen saver.

| | |
|-----|-----------------------------|
| ON | Turns on the screen saver. |
| OFF | Turns off the screen saver. |

BACKGROUND

Selects the background colour or picture on the TV screen when the player is in stop mode or while playing a CD, or DATA CD (MP3 audio)/DATA DVD (MP3 audio).

| | |
|----------------|---|
| JACKET PICTURE | The jacket picture (still picture) appears, but only when the jacket picture is already recorded on the disc (CD-EXTRA, etc.). If the disc does not contain a jacket picture, the "GRAPHICS" picture appears. |
| GRAPHICS | A preset picture stored in the player appears. |
| BLUE | The background colour is blue. |
| BLACK | The background colour is black. |

LINE

Selects video signals output from the LINE (RGB)-TV jack on the rear panel of the player.

| | |
|---------|--------------------------|
| VIDEO | Outputs video signals. |
| S VIDEO | Outputs S video signals. |
| RGB | Outputs RGB signals. |

Notes

- If your TV does not accept S video or the RGB signals, no picture will appear on the TV screen, even if you select "S VIDEO" or "RGB." Refer to the instructions supplied with your TV.
- If your TV has only one SCART (EURO AV) jack, do not select "S VIDEO."
- When you select "RGB," you cannot use the PROGRESSIVE button or the COMPONENT VIDEO OUT jacks.
- You cannot select "RGB" while the HDMI indicator is lit. "RGB" automatically switches to "VIDEO" when you turn on any connected HDMI equipment.

4:3 OUTPUT

This setting is effective only when you set "TV TYPE" in "SCREEN SETUP" to "16:9." Adjust this to watch 4:3 aspect ratio progressive signals. If you can change the aspect ratio on your progressive format (525p/625p) compatible TV, change the setting on your TV, not the player. This setting is effective only when "PROGRESSIVE AUTO" or "PROGRESSIVE VIDEO" is selected by using the PROGRESSIVE button on the front panel.

| | |
|--------|---|
| FULL | Select this when you can change the aspect ratio on your TV. |
| NORMAL | Select this when you cannot change the aspect ratio on your TV. Shows a 16:9 aspect ratio signal with black bands on left and right sides of the image. |

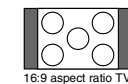

16:9 aspect ratio TV

Settings and Adjustments

Settings and Adjustments

Custom Settings (CUSTOM SETUP)

Use this to set up playback related and other settings.

Select "CUSTOM SETUP" in the Setup Display. To use the display, see "Using the Setup Display" (page 64). The default settings are underlined.

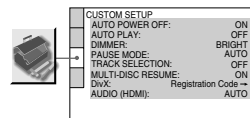

◆ AUTO POWER OFF

Switches the Auto Power Off setting on or off.

| | |
|-----------|---|
| <u>ON</u> | The player enters standby mode when left in stop mode for more than 30 minutes. |
| OFF | Switches this function off. |

◆ AUTO PLAY

Switches the Auto Play setting on or off. This function is useful when the player is connected to a timer (not supplied).

| | |
|-----------|---|
| OFF | Switches this function off. |
| <u>ON</u> | Automatically starts playback when the player is turned on by a timer (not supplied). |

◆ DIMMER

Adjusts the lighting of the front panel display.

| | |
|---------------|---|
| <u>BRIGHT</u> | Makes the lighting bright. |
| DARK | Makes the lighting dark. |
| AUTO DARK | Makes the lighting dark if you do not operate the player or remote for a short while. |

◆ AUDIO FILTER

Selects the digital filter to reduce noise above 22.05 kHz (Sampling frequency (Fs) of the audio source is 44.1 kHz), 24 kHz (Fs is 48 kHz), or 48 kHz (Fs is above 96 kHz).

| | |
|--------------|--|
| <u>SHARP</u> | Provides a wide frequency range and spatial feeling. |
| SLOW | Provides smooth and warm sound. |

Note

There may be little effect by changing the digital filter depending on the disc or playback environment.

◆ DOWNMIX (DVD VIDEO/DVD-VR mode only)

Switches the method for mixing down to 2 channels when you play a DVD which has rear sound elements (channels) or is recorded in Dolby Digital format. For details on the rear signal components, see "Checking the audio signal format" (page 41). This function affects the output of the following jacks:
 -LINE OUT L/R (AUDIO) jacks
 -LINE (RGB)-TV jack
 -DIGITAL OUT (OPTICAL or COAXIAL)/HDMI OUT jack when "DOLBY DIGITAL" is set to "D-PCM" (page 70).

| | |
|-----------------------|--|
| <u>DOLBY SURROUND</u> | Normally, select this position. Multi-channel audio signals are output to 2 channels for enjoying surround sounds. |
| NORMAL | Multi-channel audio signals are downmixed to 2 channels for use with your stereo. |

◆ DIGITAL OUT

Selects if audio signals are output via the DIGITAL OUT (OPTICAL or COAXIAL)/HDMI OUT jack.

| | |
|-----------|---|
| <u>ON</u> | Normally select this position. When you select "ON," see "Setting the digital output signal" for further settings. |
| OFF | The influence of the digital circuit upon the analog circuit is minimal. If you are using the HDMI OUT jack, PCM sound will be output depending on the connected equipment. If the signal is encrypted for copyright protection purposes, the signal is only output as 48 kHz/16 bit PCM. |

◆ PAUSE MODE (DVD VIDEO/DVD-VR mode only)

Selects the picture in pause mode.

| | |
|-------------|---|
| <u>AUTO</u> | The picture, including subjects that move dynamically, is output with no jitter. Normally select this position. |
| FRAME | The picture, including subjects that do not move dynamically, is output in high resolution. |

◆ TRACK SELECTION (DVD VIDEO only)

Gives the sound track which contains the highest number of channels priority when you play a DVD VIDEO on which multiple audio formats (PCM, MPEG audio, DTS, or Dolby Digital format) are recorded.

| | |
|-------------|--------------------|
| OFF | No priority given. |
| <u>AUTO</u> | Priority given. |

Notes

- When you set the item to "AUTO," the language may change. The "TRACK SELECTION" setting has higher priority than the "AUDIO" settings in "LANGUAGE SETUP" (page 65).
- If PCM, DTS, MPEG audio, and Dolby Digital sound tracks have the same number of channels, the player selects PCM, DTS, MPEG, and Dolby Digital audio sound tracks in this order.

◆ MULTI-DISC RESUME (DVD VIDEO/VIDEO CD only)

Switches the Multi-disc Resume setting on or off. Resume playback can be stored in memory for up to 6 different DVD VIDEOS/VIDEO CDs (page 26).

| | |
|-----------|---|
| <u>ON</u> | Stores the resume setting in memory for up to 6 discs. |
| OFF | Does not store the resume setting in memory. Playback restarts at the resume point only for the current disc in the player. |

Note

If you run Quick Setup, Multi-disc Resume settings stored in memory may return to the default settings.

Setting the digital output signal

Switches the method of outputting audio signals when you connect a component such as an amplifier (receiver) or MD deck with a digital input jack.

For connection details, see page 20. Select "DOLBY DIGITAL," "MPEG," "DTS," and "48kHz/96kHz PCM" after setting "DIGITAL OUT" to "ON."

If you connect a component that is incompatible with the selected audio signal, a loud noise (or no sound) may be heard from the speakers, risking damage to your ears or speakers.

Notes

- The AV SYNC function (page 49) is not effective if you use the DIGITAL OUT (OPTICAL or COAXIAL) jack, and set "DOLBY DIGITAL," "MPEG" or "DTS" to "DOLBY DIGITAL," "MPEG" or "ON" respectively.
- The AV SYNC function (page 49) is not effective if you connect a Dolby Digital or DTS-compliant device via the HDMI OUT jack, and set "DOLBY DIGITAL," "MPEG" or "DTS" to "DOLBY DIGITAL," "MPEG" or "ON" respectively.

◆ DOLBY DIGITAL (DVD VIDEO/DVD-VR mode only)

Selects the type of Dolby Digital signal.

| | |
|---------------|--|
| <u>D-PCM</u> | Select this when the player is connected to an audio component without a built-in Dolby Digital decoder. You can select whether the signals conform to Dolby Surround (Pro Logic) or not by making adjustments to the "DOWNMIX" item in "AUDIO SETUP" (page 69). |
| DOLBY DIGITAL | Select this when the player is connected to an audio component with a built-in Dolby Digital decoder. |

Note

If the HDMI OUT jack is connected to equipment not compatible with DOLBY DIGITAL signals, the "D-PCM" signals will be automatically output even when you select "DOLBY DIGITAL."

◆ DivX

Displays the registration code for this player. For more information, go to <http://www.divx.com> on the Internet.

◆ AUDIO (HDMI)

Selects the type of audio signal output from the HDMI OUT jack.

| | |
|-------------|---|
| <u>AUTO</u> | Normally, select this. Outputs audio signals according to the "DIGITAL OUT" settings (page 70). |
| PCM | Converts Dolby Digital, or 96 kHz/24 bit PCM signals to 48 kHz/16 bit PCM. |

Note

A loud noise (or no sound) will be output if you connect the player to a TV that is not compatible with DOLBY DIGITAL/DTS signals and "AUTO" is selected. In this case, select "PCM."

Settings for the Sound (AUDIO SETUP)

"AUDIO SETUP" allows you to set the sound according to the playback and connection conditions.

Select "AUDIO SETUP" in the Setup Display. To use the display, see "Using the Setup Display" (page 64). The default settings are underlined.

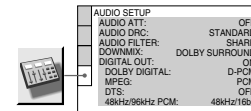

◆ AUDIO ATT (attenuation)

If the playback sound is distorted, set this item to "ON." The player reduces the audio output level.

This function affects the output of the following jacks:

- LINE OUT L/R (AUDIO) jacks
- LINE (RGB)-TV jack

| | |
|-----------|---|
| OFF | Normally, select this position. |
| <u>ON</u> | Select this when the playback sound from the speakers is distorted. |

◆ AUDIO DRC (Dynamic Range Control) (DVD VIDEO/DVD-VR mode only)

Makes the sound clear when the volume is turned down when playing a DVD that conforms to "AUDIO DRC."

This function affects the output from the following jacks:

- LINE OUT L/R (AUDIO) jacks
- LINE (RGB)-TV jack
- DIGITAL OUT (OPTICAL or COAXIAL)/HDMI OUT jack only when "DOLBY DIGITAL" is set to "D-PCM" (page 70).

| | |
|-----------------|--|
| <u>STANDARD</u> | Normally select this position. |
| TV MODE | Makes low sounds clear even if you turn the volume down. |
| WIDE RANGE | Gives you the feeling of being at a live performance. |

Notes

- The analogue audio signals from the LINE OUT L/R (AUDIO) jacks are not affected by this setting and keep their original sampling frequency level.
- If the HDMI OUT jack is connected to equipment not compatible with 96 kHz/24 bit signals, 48 kHz/16 bit PCM will be automatically output even when you select "96kHz/24bit."

◆ MPEG (DVD VIDEO/DVD-VR mode only)

Selects the type of MPEG audio signal.

| | |
|------------|--|
| <u>PCM</u> | Select this when the player is connected to an audio component without a built-in MPEG decoder. If you play multi-channel MPEG audio sound tracks, only the Front (L) and Front (R) signals will be output from your two front speakers. |
| MPEG | Select this when the player is connected to an audio component with a built-in MPEG decoder. |

Note

If the HDMI OUT jack is connected to equipment not compatible with MPEG audio signal, the "PCM" signals will be automatically output even when you select "MPEG."

◆ DTS

Selects the type of DTS audio signals.

| | |
|-----------|--|
| OFF | Select this when the player is connected to an audio component without a built-in DTS decoder. |
| <u>ON</u> | Select this when the player is connected to an audio component with a built-in DTS decoder. |

Note

If the HDMI OUT jack is connected to equipment not compatible with DTS signals, the "OFF" signals will be automatically output even when you select "ON."

◆ 48kHz/96kHz PCM (DVD VIDEO only)

Selects the sampling frequency of the audio signal.

| | |
|--------------------|--|
| <u>48kHz/16bit</u> | The audio signals of DVD VIDEOS are always converted to 48kHz/16bit. |
| 96kHz/24bit | All types of signals including 96kHz/24bit are output in their original format. However, if the signal is encrypted for copyright protection purposes, the signal is only output as 48kHz/16bit. |

Additional Information

Troubleshooting

If you experience any of the following difficulties while using the player, use this troubleshooting guide to help remedy the problem before requesting repairs. Should any problem persist, consult your nearest Sony dealer.

Power

The power is not turned on.

- ➔ Check that the mains lead is connected securely.

Picture

There is no picture/picture noise appears.

- ➔ Re-connect the connecting cord securely.
- ➔ The connecting cords are damaged.
- ➔ Check the connection to your TV (page 16) and switch the input selector on your TV so that the signal from the player appears on the TV screen.
- ➔ Set "LINE" in "SCREEN SETUP" to an item appropriate for your system (page 66).
- ➔ The disc is dirty or flawed.
- ➔ If the picture output from your player goes through your VCR to get to your TV or if you are connected to a combination TV/VIDEO player, the copy-protection signal applied to some DVD programmes could affect picture quality. If you still experience problems even when you connect your player directly to your TV, try connecting your player to your TV's S VIDEO input (page 16).
- ➔ The disc is recorded in a colour system that is different from your TV.
- ➔ You have selected "PROGRESSIVE AUTO" or "PROGRESSIVE VIDEO" using the PROGRESSIVE button on the front panel (the PROGRESSIVE indicator lights up) even though your TV cannot accept the progressive signal. In this case, disconnect the HDMI cord from the player, and then select "NORMAL (INTERLACE)" so that the PROGRESSIVE indicator turns off.

- ➔ Even if your TV is compatible with progressive format 525p/625p signals, the image may be affected when you set the player to progressive format. In this case, select "NORMAL (INTERLACE)" using the PROGRESSIVE button on the front panel so that the PROGRESSIVE indicator turns off and the player is set to normal (interlace) format.
- ➔ If you set "LINE" to "RGB" in "SCREEN SETUP" (page 66), the player outputs no component video signals.
- ➔ The player is connected to an input device that is not HDCP compliant (the HDMI indicator on the front panel does not light up). See page 17.
- ➔ If the HDMI OUT jack is used for video output, changing the "HDMI RESOLUTION" setting in "SCREEN SETUP" may solve the problem (page 66). Connect the TV and the player using a video jack other than the HDMI OUT, and switch the TV's input to the connected video input so that you can see the on-screen displays. Change the "HDMI RESOLUTION" setting in "SCREEN SETUP," and switch the TV's input back to HDMI. If the picture still does not appear, repeat the steps and try other options.
- ➔ If the signal from the LINE OUT (VIDEO) or S VIDEO OUT jacks is distorted, change the "HDMI RESOLUTION" setting in "SCREEN SETUP" to "720 x 480/576p."

There is no picture or the picture noise appears when connected to the HDMI OUT jack.

- ➔ Try the following: ① Turn the player off and on again. ② Turn the connected equipment off and on again. ③ Disconnect the HDMI OUT jack is connected to a DVI device (DVI jacks do not accept audio signals).

The picture does not fill the screen, even though the aspect ratio is set in "TV TYPE" under "SCREEN SETUP."

- ➔ The aspect ratio of the disc is fixed on your DVD.

The picture is black and white.

- ➔ Set "LINE" in "SCREEN SETUP" to an item appropriate for your TV (page 66).
- ➔ Depending on the TV, the picture on the screen becomes black and white when you play a disc recorded in the NTSC colour system.
- ➔ If you are using a SCART cord, be sure to use one that is fully wired (21-pins).

Some functions such as Stop, Search, Fast Play and Slow Play, Slow-motion Play, Repeat Play, Shuffle Play, or Programme Play cannot be performed.

- ➔ Depending on the disc, you may not be able to do some of the operations above. Refer to the operating manual that comes with the disc.

The language for the sound track cannot be changed.

- ➔ Try using the DVD's menu instead of the direct selection button on the remote (page 27).
- ➔ Multilingual tracks are not recorded on the DVD being played.
- ➔ The DVD prohibits the changing of the language for the sound track.

The subtitle language cannot be changed or turned off.

- ➔ Try using the DVD's menu instead of the direct selection button on the remote (page 27).
- ➔ Multilingual subtitles are not recorded on the DVD being played.
- ➔ The DVD prohibits the changing of subtitles.

The angles cannot be changed.

- ➔ Try using the DVD's menu instead of the direct selection button on the remote (page 27).
- ➔ Multi-angles are not recorded on the DVD being played.
- ➔ The angle can only be changed when the "ANGLE" indicator lights up on the front panel display (page 10).
- ➔ The DVD prohibits changing of the angles.

The player does not operate properly.

- ➔ When static electricity, etc., causes the player to operate abnormally, unplug the player.

5 numbers or letters are displayed on the screen and on the front panel display.

- ➔ The self-diagnosis function was activated. (See the table on page 75.)

Sound

There is no sound.

- ➔ Re-connect the connecting cord securely.
- ➔ The connecting cord is damaged.
- ➔ The player is connected to the wrong input jack on the amplifier (receiver) (page 20).
- ➔ The amplifier (receiver) input is not correctly set.
- ➔ The player is in pause mode or in Slow-motion Play mode.
- ➔ The player is in fast forward or fast reverse mode.
- ➔ If the audio signal does not come through the DIGITAL OUT (OPTICAL or COAXIAL)/HDMI OUT jack, check the audio settings (page 70).
- ➔ While playing a Super VCD on which the audio track 2 is not recorded, no sound will come out when you select "2:STEREO," "2:1/L," or "2:2/R."
- ➔ When playing multichannel MPEG audio soundtracks, only the Front (L) and Front (R) signal will be output from your two front speakers.
- ➔ The equipment connected to the HDMI OUT jack does not conform to the audio signal format, in this case set "AUDIO(HDMI)" in "AUDIO SETUP" to "PCM" (page 69).

No sound is output from the HDMI OUT jack

- ➔ Try the following: ① Turn the player off and on again. ② Turn the connected equipment off and on again. ③ Disconnect and then connect the HDMI cord again.
- ➔ The HDMI OUT jack is connected to a DVI device (DVI jacks do not accept audio signals).

Sound distortion occurs.

- ➔ Set "AUDIO ATT" in "AUDIO SETUP" to "ON" (page 69).

The sound volume is low.

- ➔ The sound volume is low on some DVDs. The sound volume may improve if you set "AUDIO DRC" in "AUDIO SETUP" to "TV MODE" (page 69).
- ➔ Set "AUDIO ATT" in "AUDIO SETUP" to "OFF" (page 69).

Operation

The remote does not function.

- ➔ The batteries in the remote are weak.
- ➔ There are obstacles between the remote and the player.
- ➔ The distance between the remote and the player is too far.
- ➔ The remote is not pointed at the remote sensor on the player.

The disc does not play.

- ➔ The disc is turned over. Insert the disc with the playback side facing down.
- ➔ The disc is skewed.
- ➔ The player cannot play certain discs (page 7).
- ➔ The region code on the DVD does not match the player.
- ➔ Moisture has condensed inside the player (page 3).
- ➔ The player cannot play a recorded disc that is not correctly finalized (page 7).

The MP3 audio track cannot be played (page 52).

- ➔ The DATA CD is not recorded in an MP3 format that conforms to ISO 9660 Level 1/Level 2 or Joliet.
- ➔ The DATA DVD is not recorded in MP3 format that conform to UDF (Universal Disk Format).
- ➔ The MP3 audio track does not have the extension ".MP3."
- ➔ The data is not formatted in MP3 even though it has the extension ".MP3."
- ➔ The data is not MPEG-1 Audio Layer III data.
- ➔ The player cannot play audio tracks in mp3PRO format.
- ➔ "MODE (MP3, JPEG)" is set to "IMAGE (JPEG)" (page 55).
- ➔ The DATA CD/DATA DVD contains a DivX video file.

The JPEG image file cannot be played (page 52).

- ➔ The DATA CD is not recorded in a JPEG format that conforms to ISO 9660 Level 1/Level 2, or Joliet.
- ➔ The DATA DVD is not recorded in JPEG format that conforms to UDF (Universal Disk Format).

Additional Information

➔ continued 73

72

- ➔ The file has an extension other than ".JPEG" or ".JPG."
- ➔ The image is larger than 3072 (width) x 2048 (height) in normal mode, or more than 3,300,000 pixels in progressive JPEG. (Some progressive JPEG files cannot be displayed even if the file size is within this specified capacity.)
- ➔ The image does not fit the screen (the image is reduced).
- ➔ "MODE (MP3, JPEG)" is set to "AUDIO (MP3)" (page 55).
- ➔ The DATA CD/DATA DVD contains a DivX video file.

The MP3 audio tracks and JPEG image files start playing simultaneously.

- ➔ "MODE (MP3, JPEG)" is set to "AUTO" (page 55).

The DivX video file cannot be played.

- ➔ The file is not created in DivX format.
- ➔ The file has an extension other than ".AVI" or ".DIVX."
- ➔ The DATA CD/DATA DVD (DivX video) is not created in a DivX format that conforms to ISO 9660 Level 1/Level 2 or Joliet/UDF.
- ➔ The DivX video file is larger than 720 (width) x 576 (height).

The album/track/file names are not displayed correctly.

- ➔ The player can only display numbers and alphabet. Other characters are displayed as "a".

The disc does not start playing from the beginning.

- ➔ Programme Play, Shuffle Play, Repeat Play, or A-B Repeat Play is selected (page 29).
- ➔ Resume play has taken effect (page 26).

The player starts playing the disc automatically.

- ➔ The disc features an auto playback function.
- ➔ "AUTO PLAY" in "CUSTOM SETUP" is set to "ON" (page 68).

Playback stops automatically.

- ➔ While playing discs with an auto pause signal, the player stops playback at the auto pause signal.

The disc tray does not open and "LOCKED" appears on the front panel display.

- ➔ Child Lock is set (page 25).

The disc tray does not open and "TRAY LOCKED" appears on the front panel display.

- ➔ Contact your Sony dealer or local authorized Sony service facility.

"Data error" appears on the TV screen when playing a DATA CD or DATA DVD.

- ➔ The MP3 audio track/JPEG image file/DivX video file you want to play is broken.
- ➔ The data is not MPEG-1 Audio Layer III data.
- ➔ The JPEG image file format does not conform to DCF (page 51).
- ➔ The JPEG image file has the extension ".JPG" or ".JPEG," but is not in JPEG format.
- ➔ The file you want to play has the extension ".AVI" or ".DIVX," but is not in DivX format, or is in DivX format but does not conform to a DivX Certified profile.

Self-diagnosis Function (When letters/numbers appear in the display)

When the self-diagnosis function is activated to prevent the player from malfunctioning, a five-character service number (e.g., C 13 50) with a combination of a letter and four digits appears on the screen and the front panel display. In this case, check the following table.



First three characters of the service number Cause and/or corrective action

| First three characters of the service number | Cause and/or corrective action |
|--|---|
| C 13 | The disc is dirty or recorded in a format that this player cannot play (page 7). ➔ Clean the disc with a cleaning cloth or check its format (page 2). |
| C 31 | The disc is not inserted correctly. ➔ Re-insert the disc correctly. |
| E XX (xx is a number) | To prevent a malfunction, the player has performed the self-diagnosis function. ➔ Contact your nearest Sony dealer or local authorized Sony service facility and give the 5-character service number. Example: E 61 10 |

Additional Information

74

75

SECTION 2 DISASSEMBLY

Note: Follow the disassembly procedure in the numerical order given.

2-1. UPPER CASE

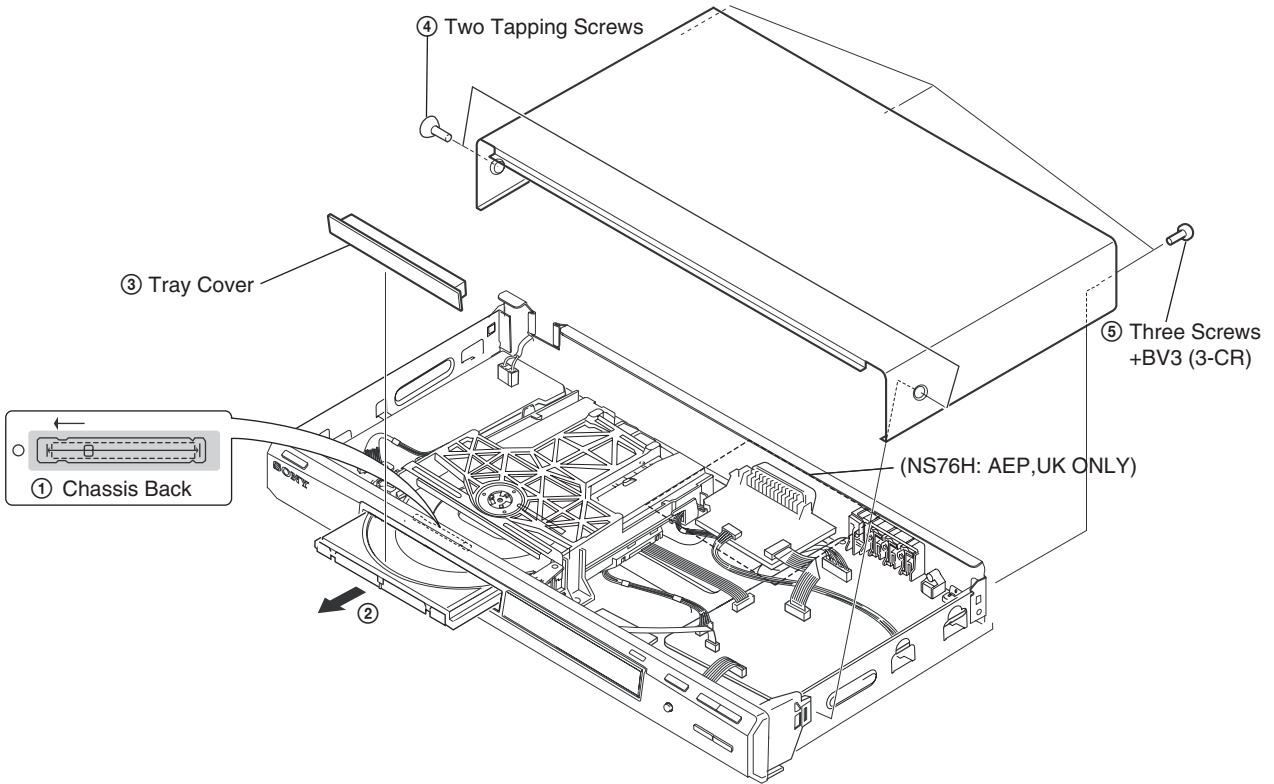

2-2. FRONT PANEL ASSEMBLY AND SW-470 BOARD

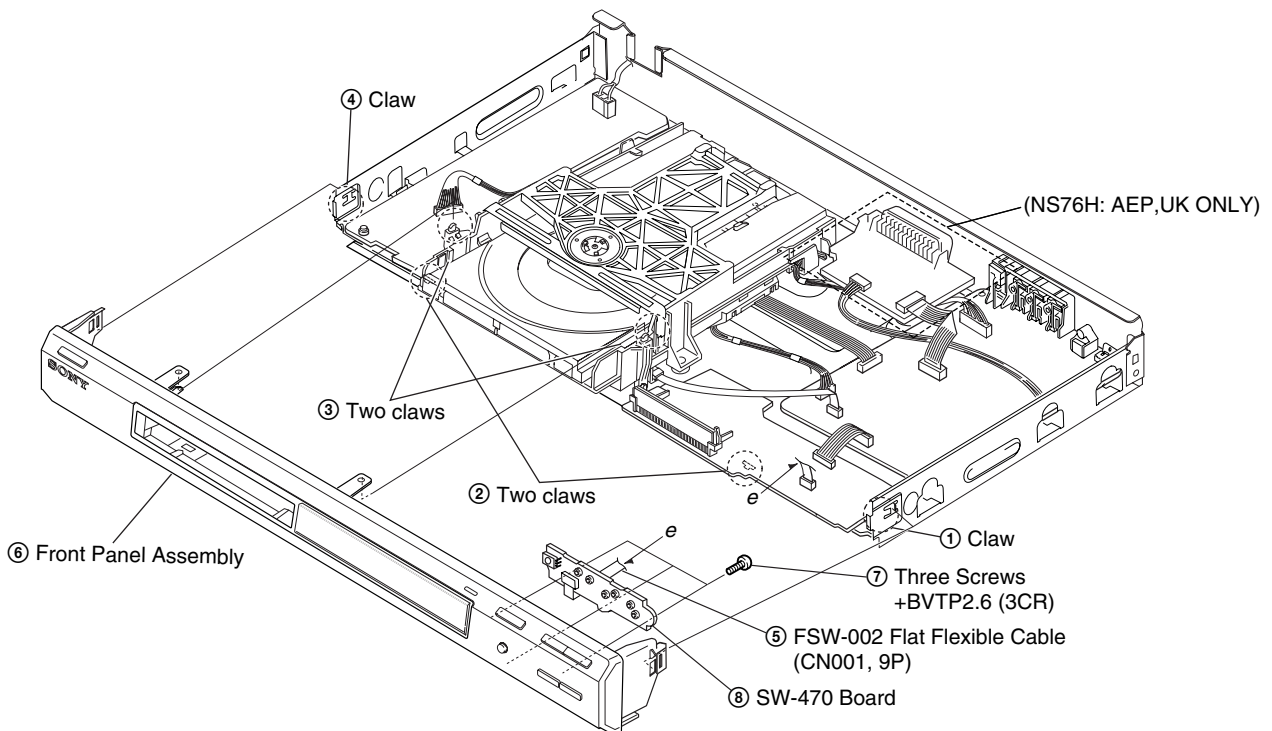

2-3. LOADING ASSEMBLY

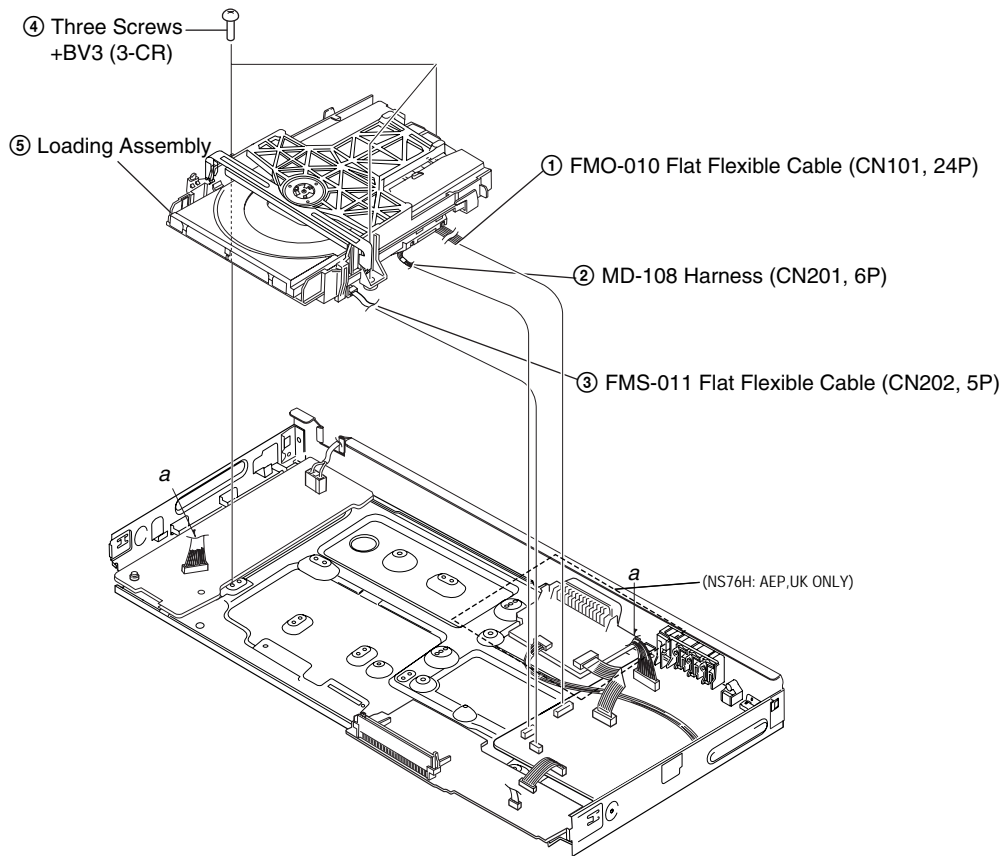

**2-4. OPTICAL PICK-UP
(DEVICE, OPTICAL KHM-313CAA/C2RP)**

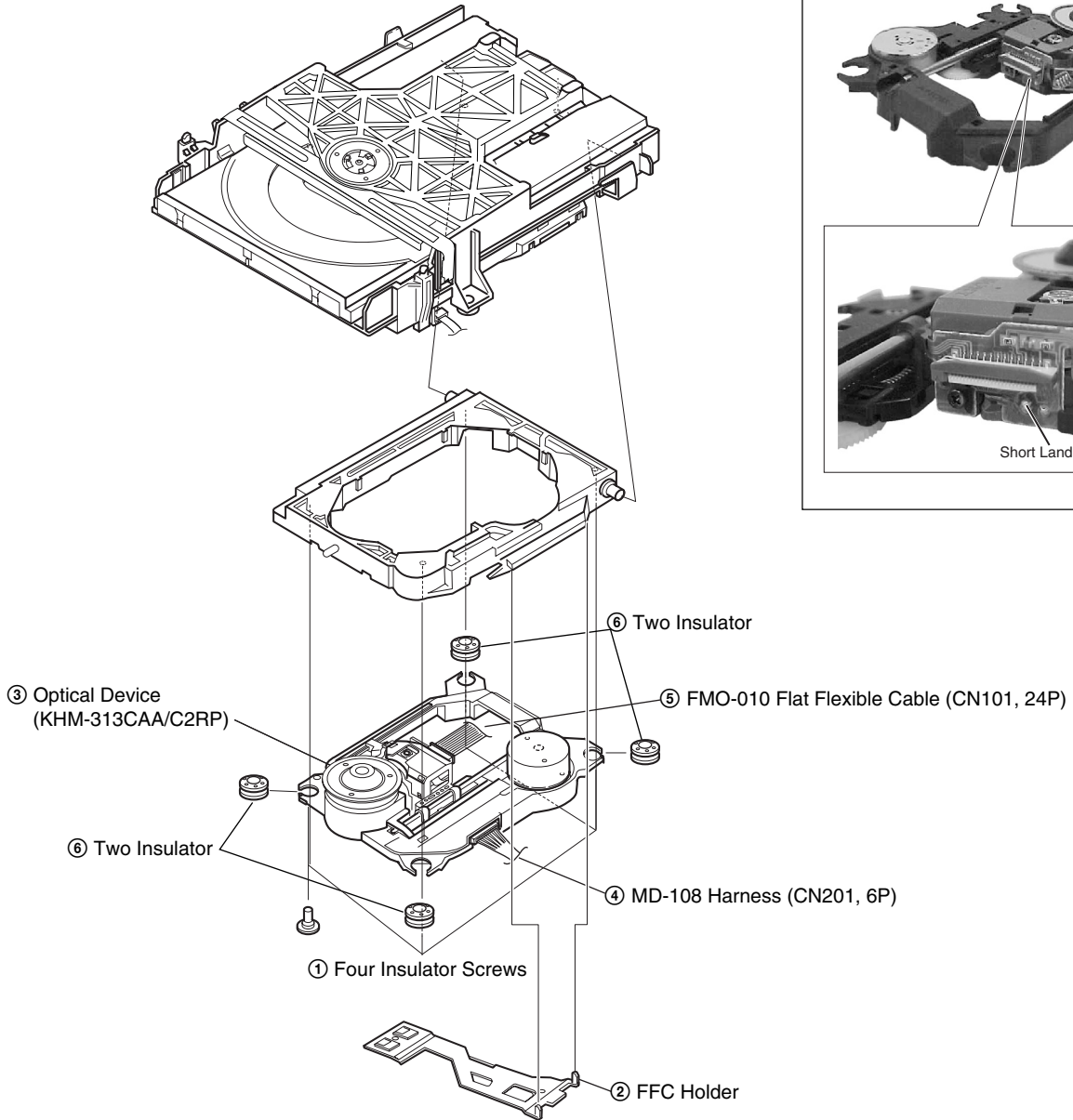

Note:

Solder short land before remove the FMO-010 Flat Flexible Cable from 24 pin BU connector.

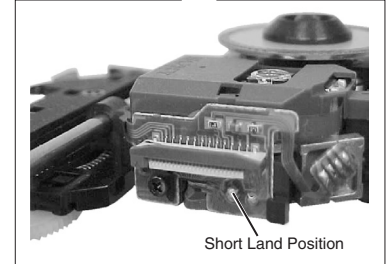
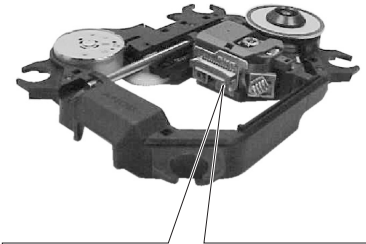

Caution Point on the Laser Diode:

Laser Diode in the optical Device is very sensitive to Surge Current or ElectroStatic Discharge (ESD):

After take-out FMO-010 Flat Flexible Cable from CN101 of MV-49 board immediately ground FMO-010 Flat Flexible Cable pattern using short clip. Metal paper clip can be used as short clip.

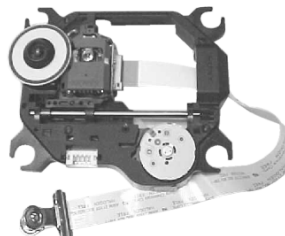

**2-5. REAR PANEL, MV-49 BOARD/
IF-146 BOARD and ER-41 BOARD**

Note:

Caution Point on the PWB IF-146

When handling IF-146 PWB avoid contact with the sharp metal edge on the top side of Vacuum Fluorescent Display (ND401).

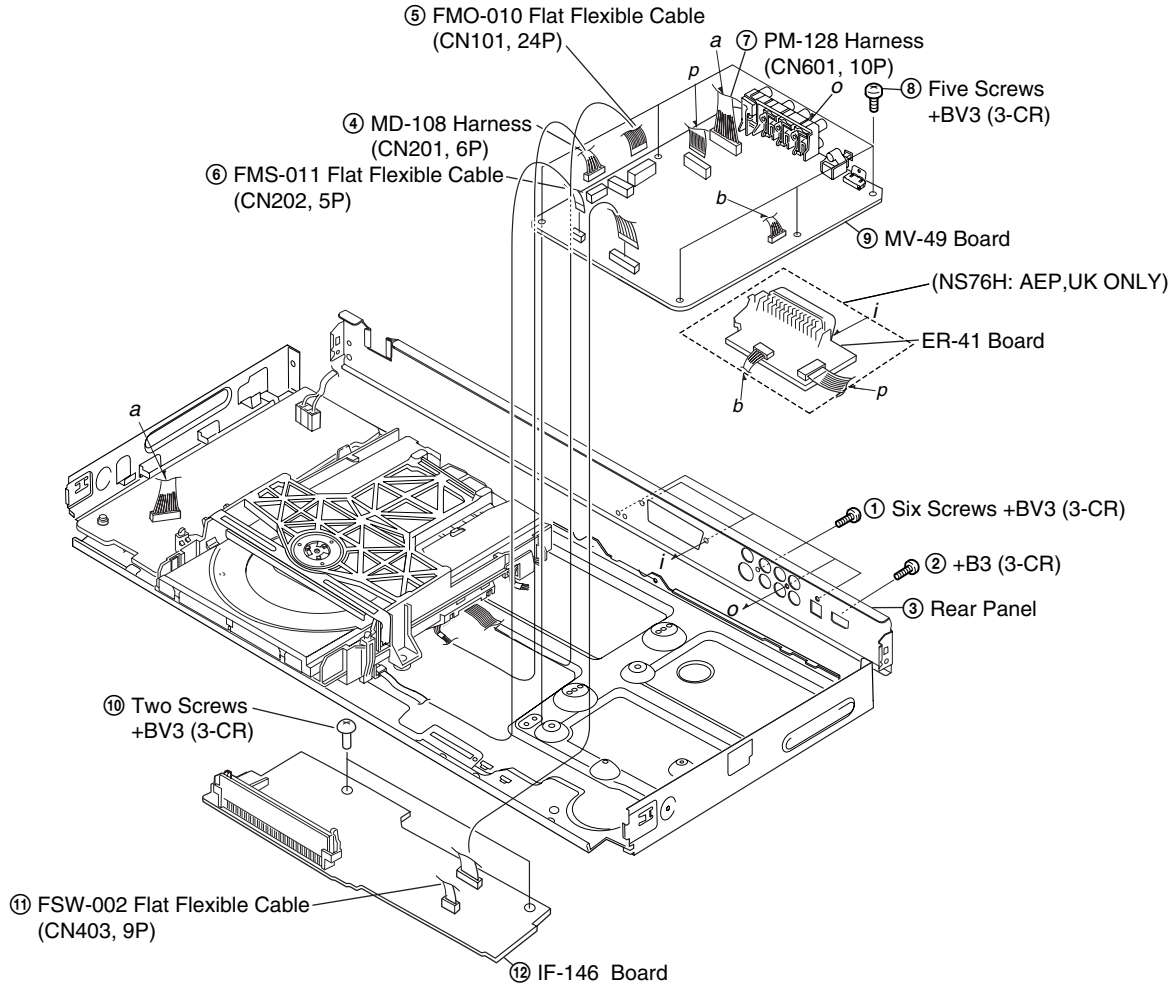

2-6. SWITCHING REGULATOR

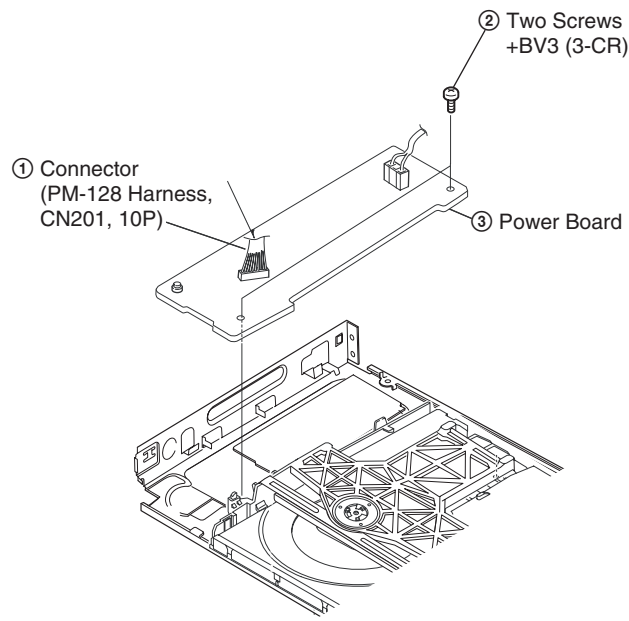

2-7. INTERNAL VIEWS



TOP VIEW

Optical Pick-Up
(Device, Optical
KHM-313CAA/C2RP/
Service Assembly)

MS-203 MOUNT

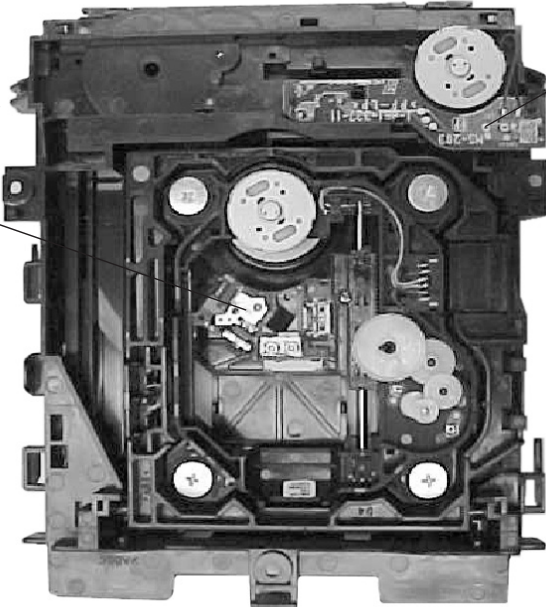

BOTTOM VIEW

2-8. CIRCUIT BOARDS LOCATION

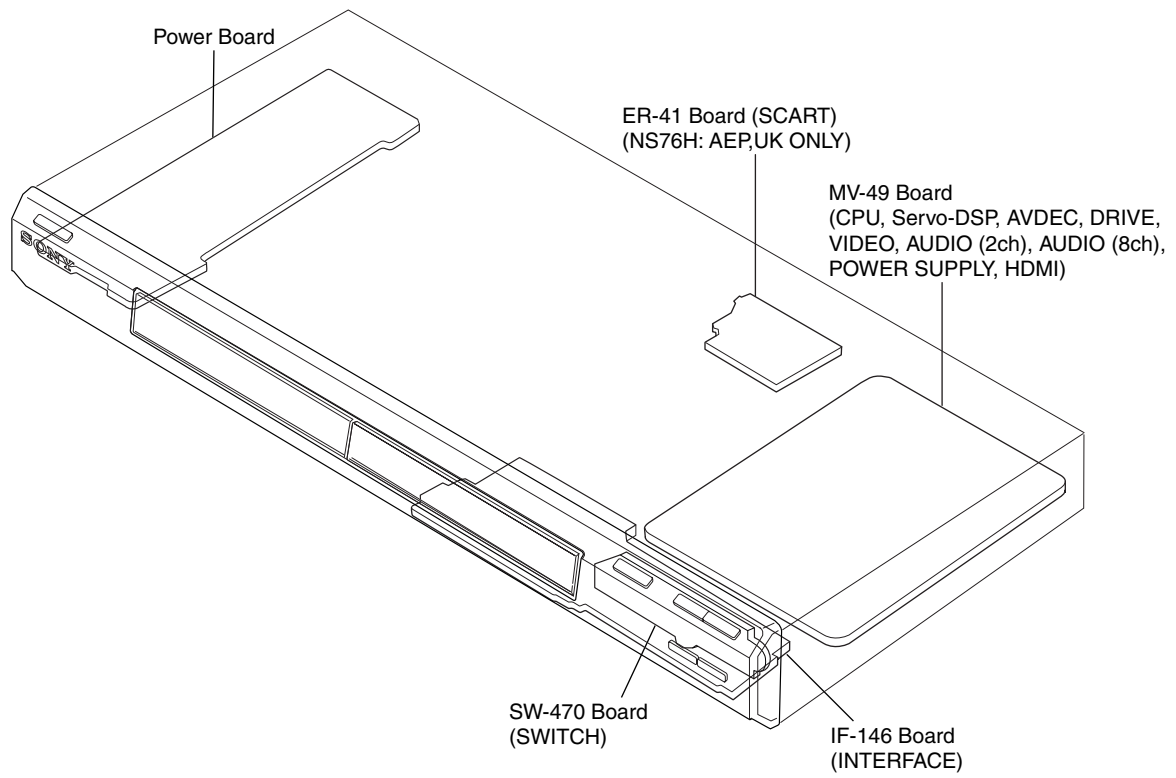

SECTION 3 BLOCK DIAGRAMS

3-1. OVERALL BLOCK DIAGRAM

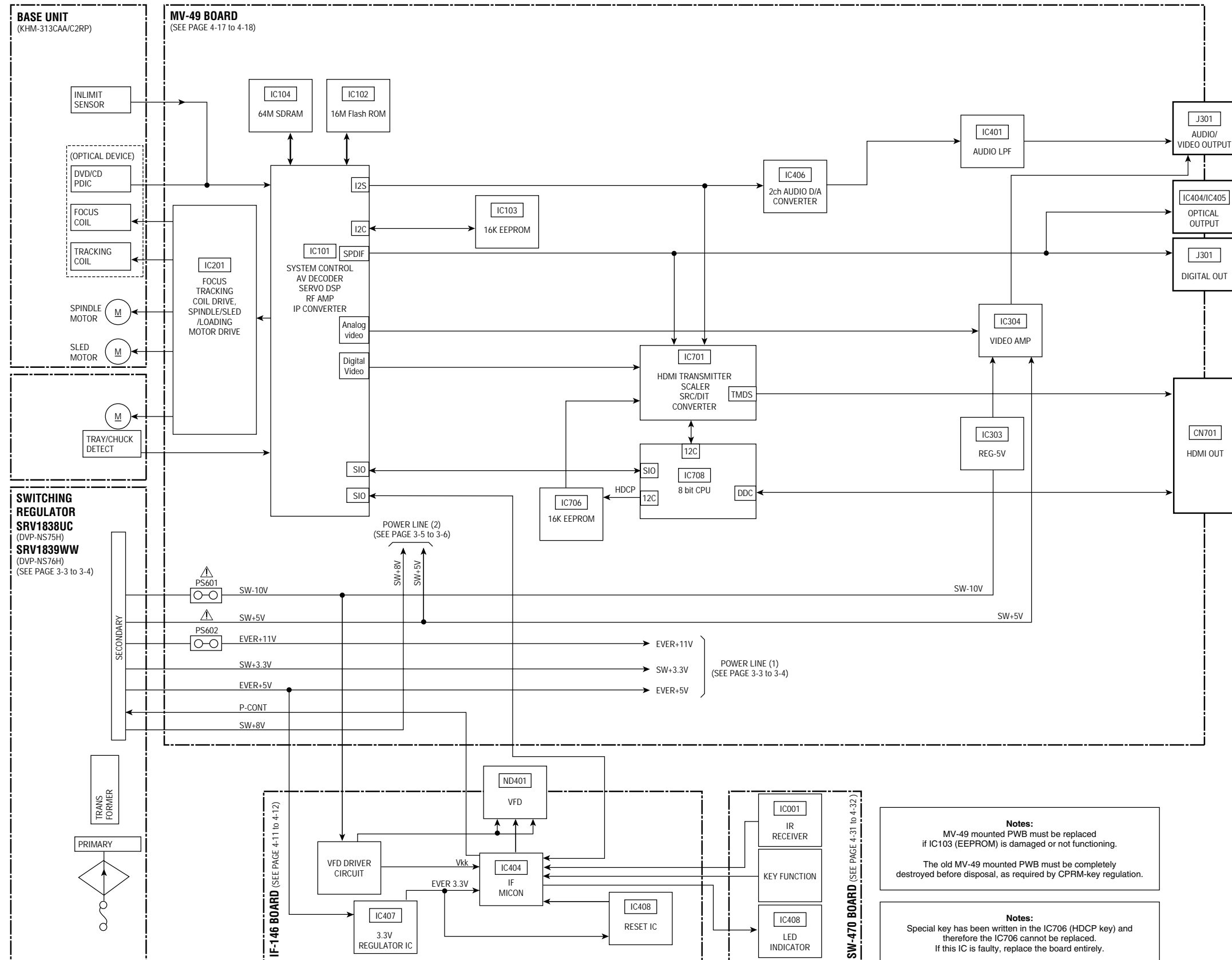

- Abbreviation
- AEP : Europe Model
- CND : Canadian Model
- E : Latin America Model
- KR : Korea Model
- RUS : Russian Model
- SP : Singapore Model

3-2. POWER LINE (1) BLOCK DIAGRAM

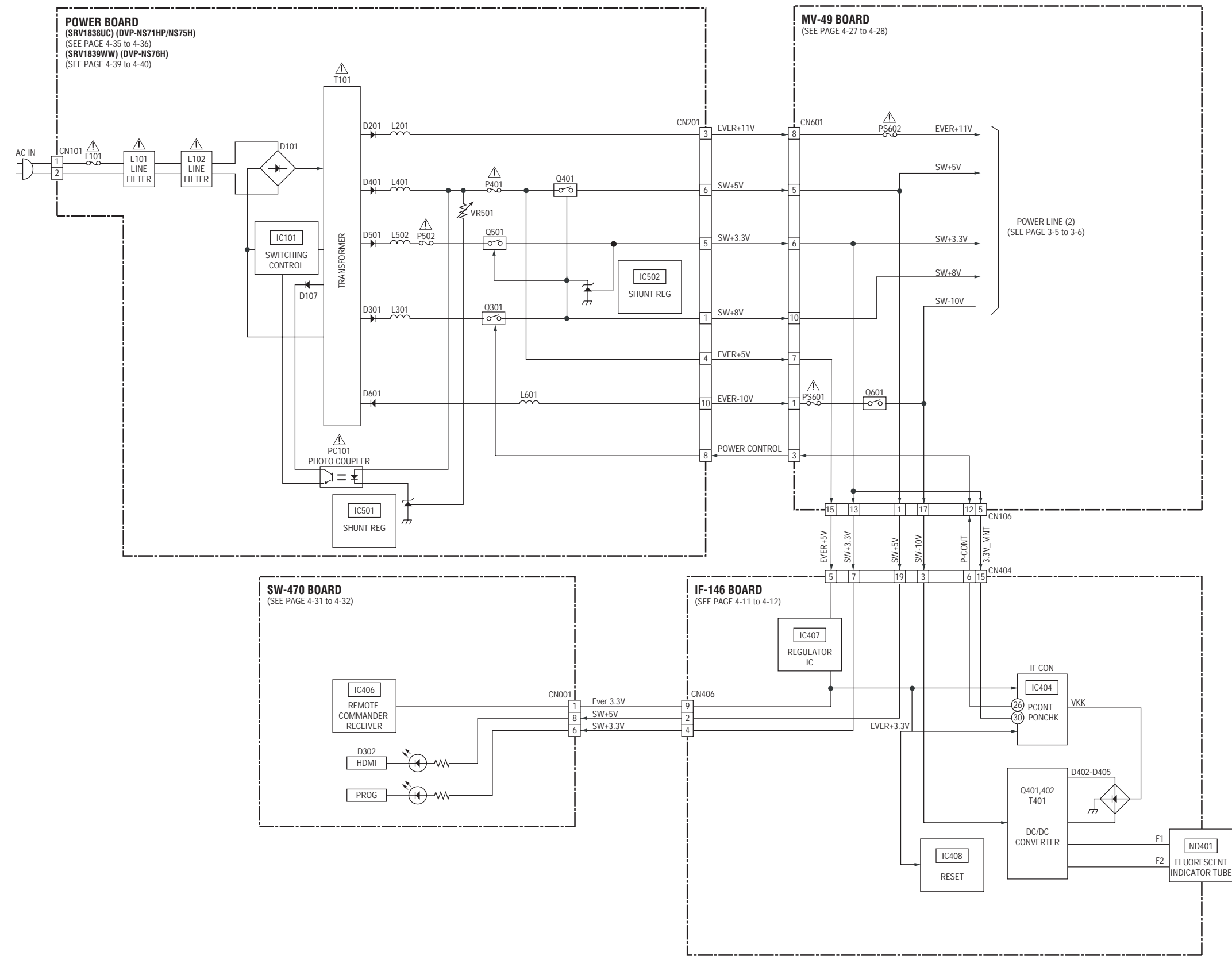

The components identified by mark Δ or dotted line with mark Δ are critical for safety. Replace only with part number specified.

3-3. POWER LINE (2) BLOCK DIAGRAM

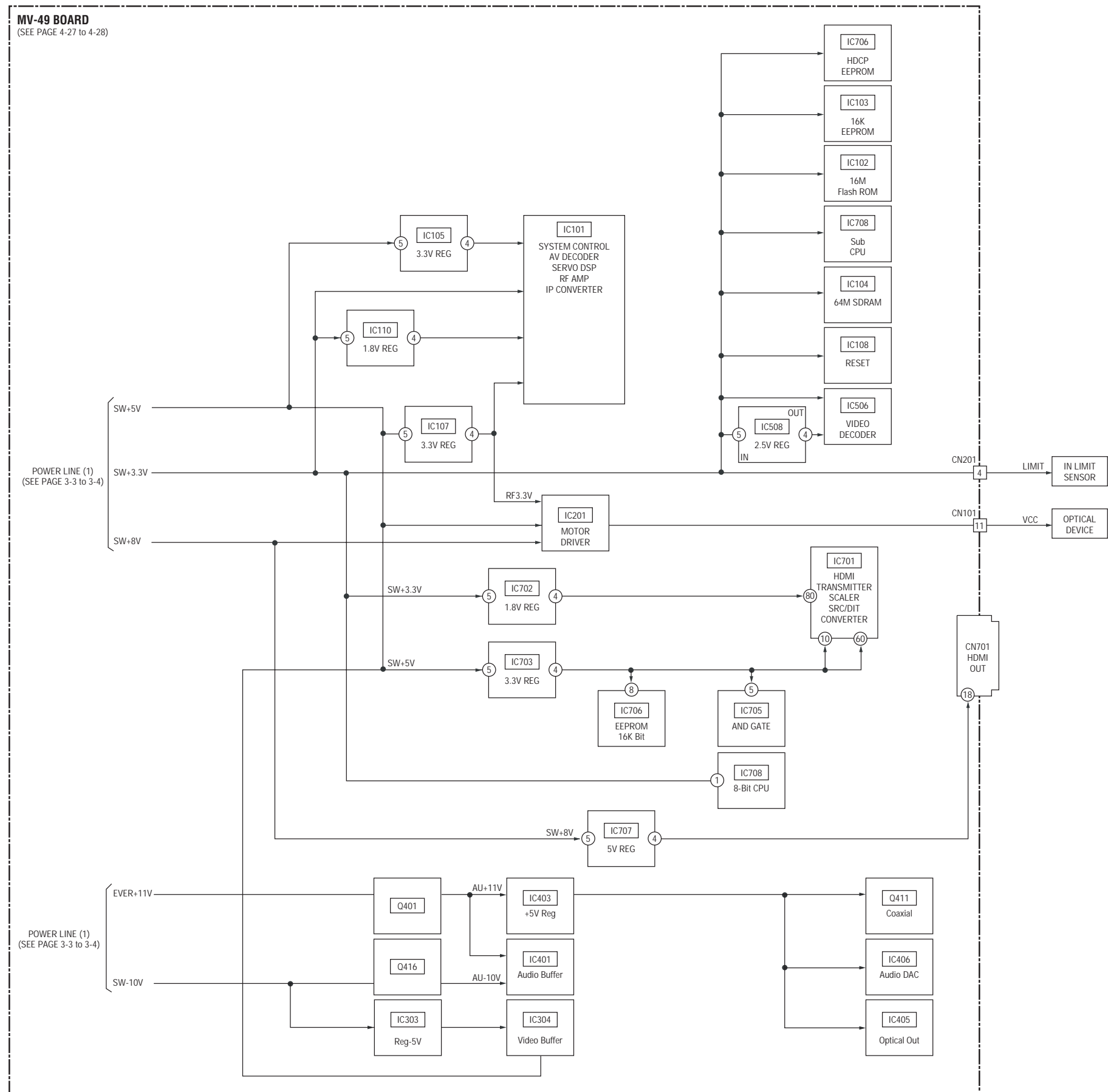

3-4. SYSTEM CONTROL/SIGNAL PROCESSOR BLOCK DIAGRAM

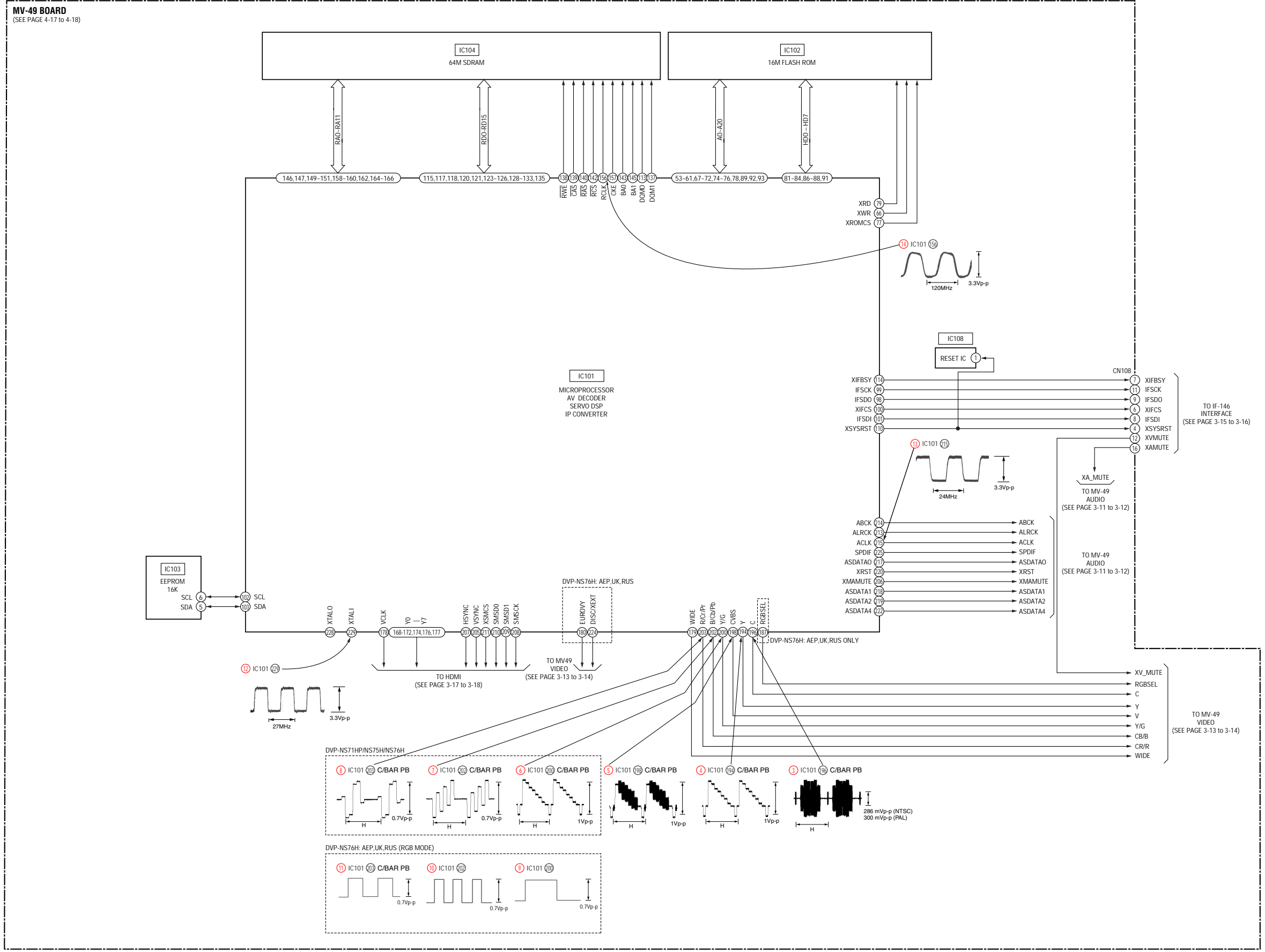

3-5. RF/SERVO BLOCK DIAGRAM

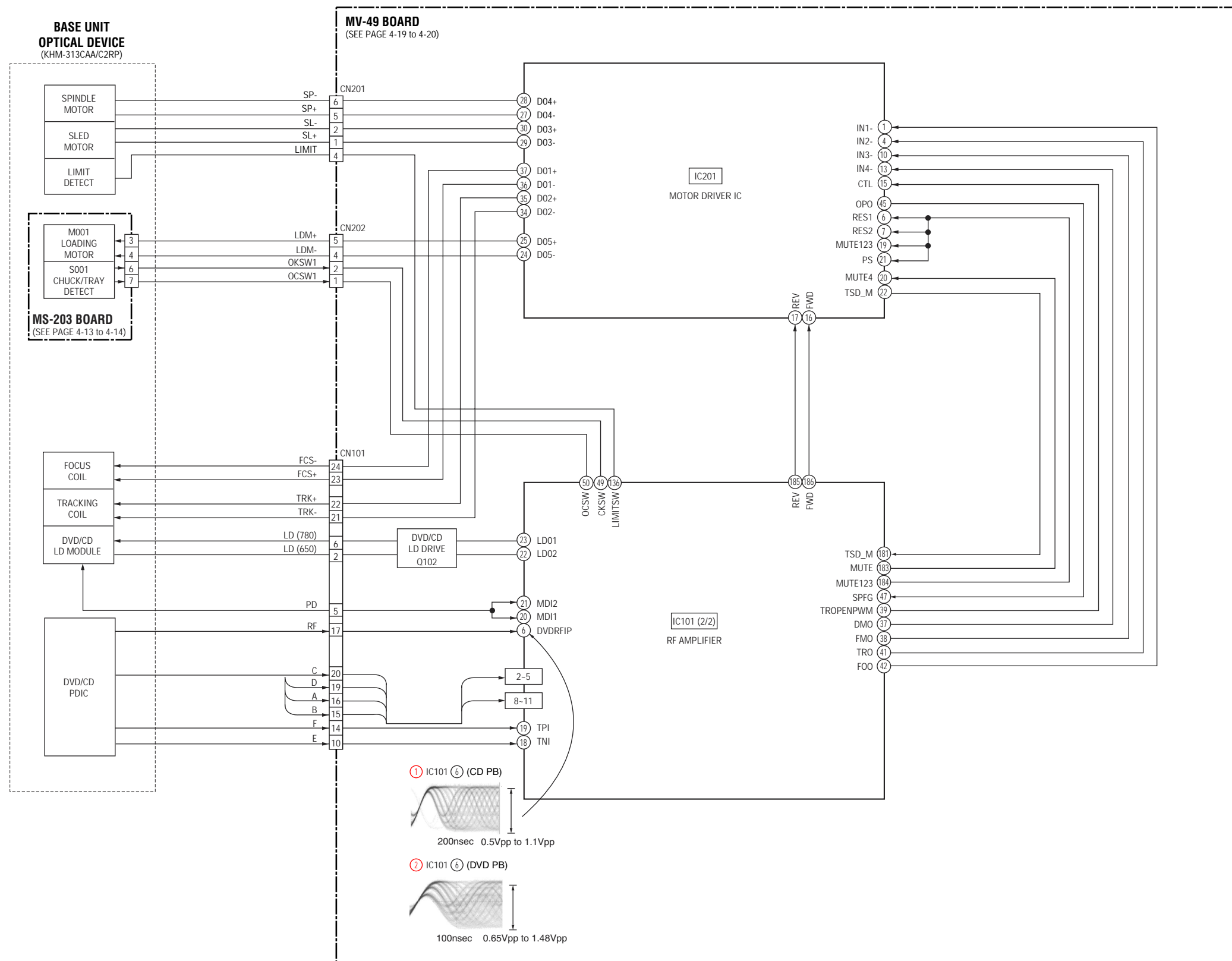

3-6. AUDIO BLOCK DIAGRAM

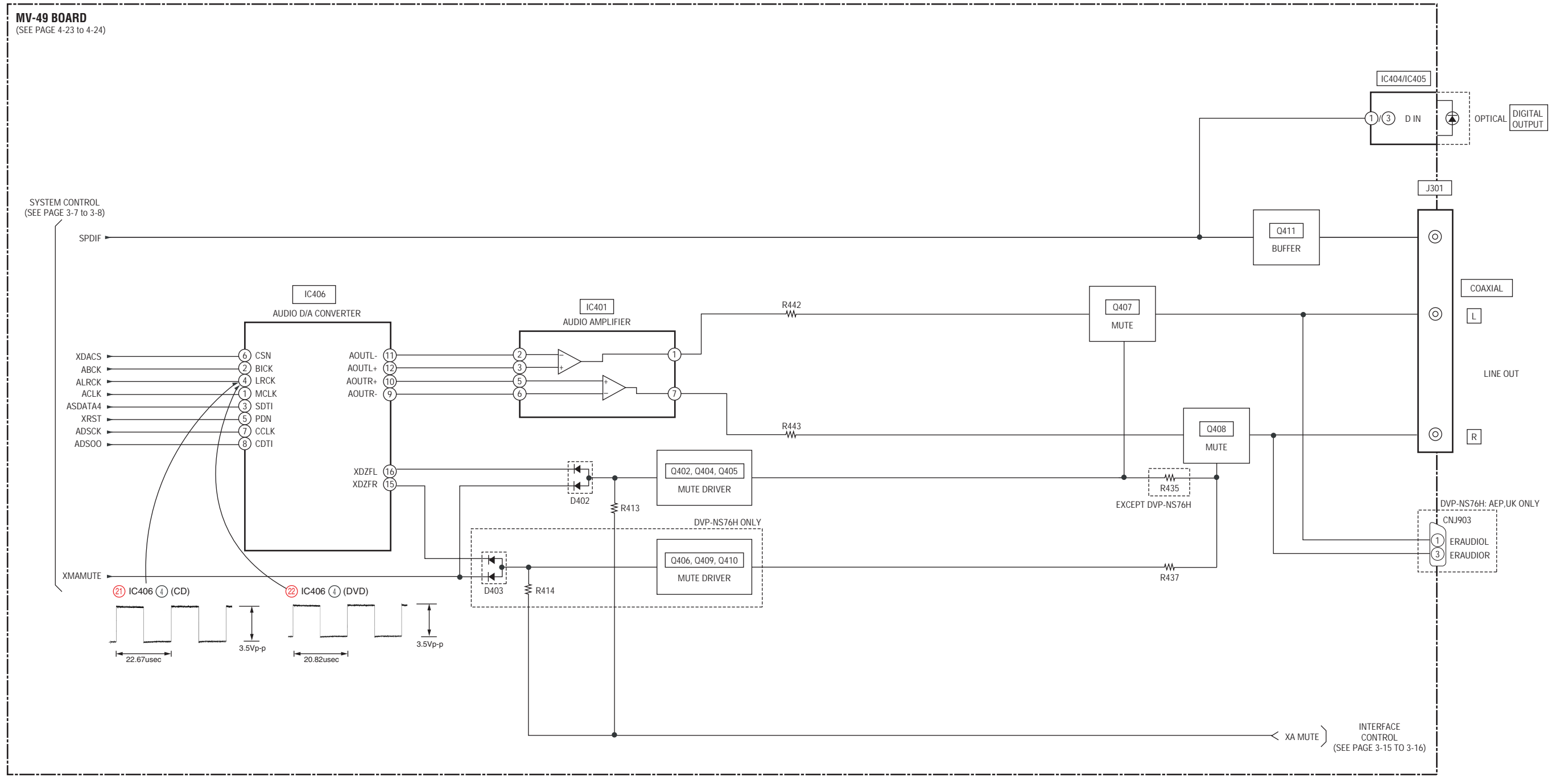

3-7. VIDEO BLOCK DIAGRAM

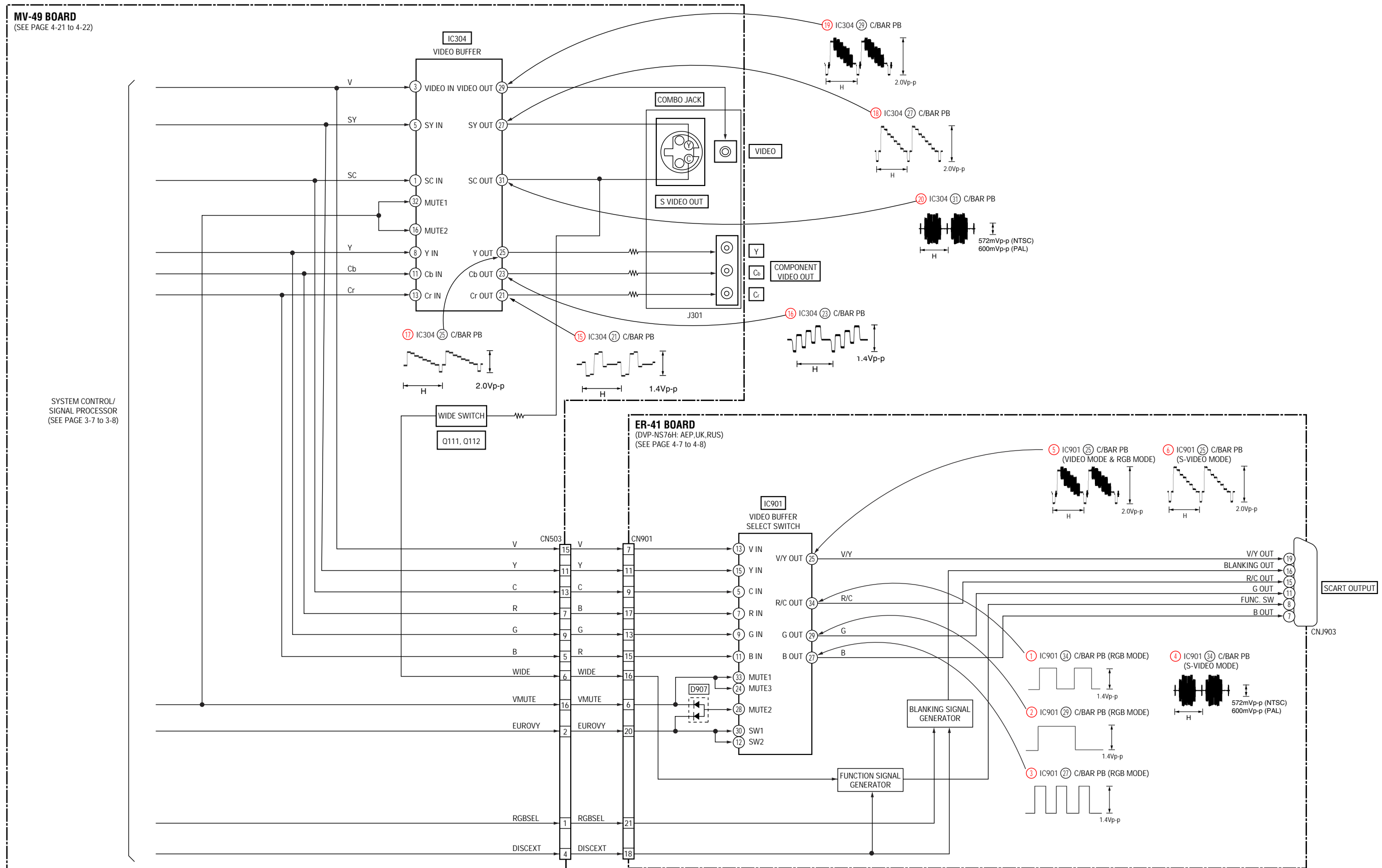

3-8. INTERFACE CONTROL BLOCK DIAGRAM

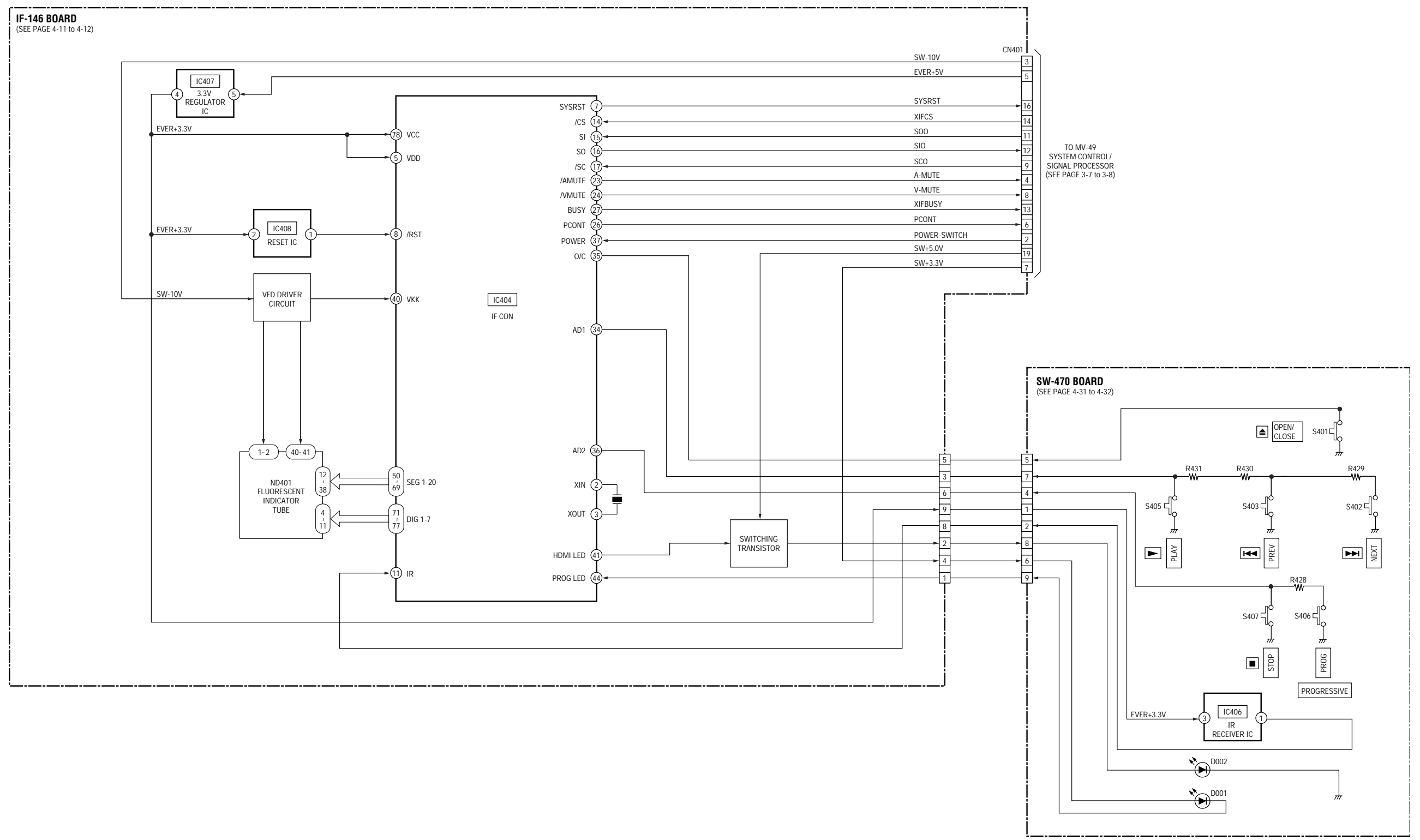

3-9. HDMI BLOCK DIAGRAM

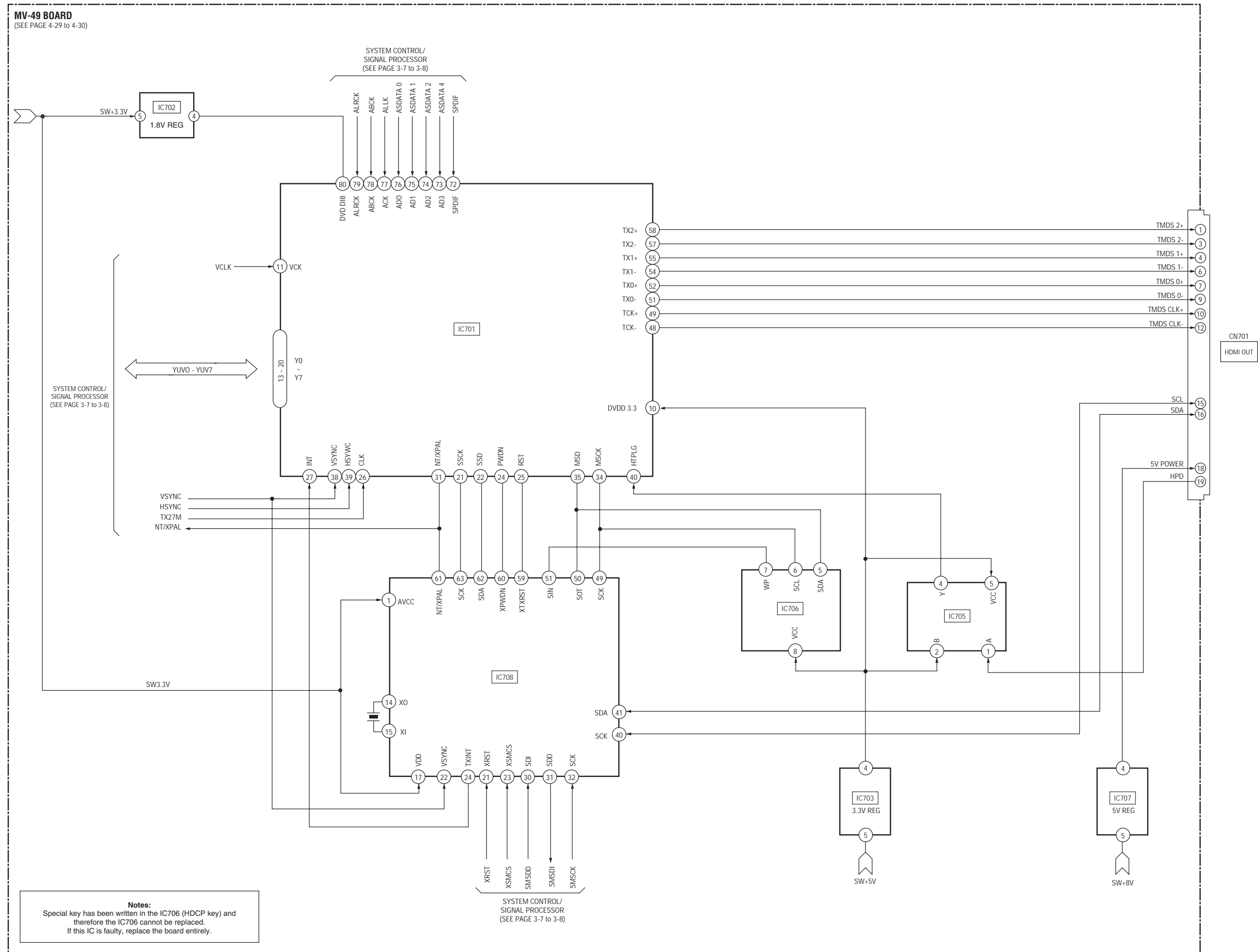

SECTION 4
PRINTED WIRING BOARDS AND SCHEMATIC DIAGRAMS

4-1. FRAME SCHEMATIC DIAGRAM

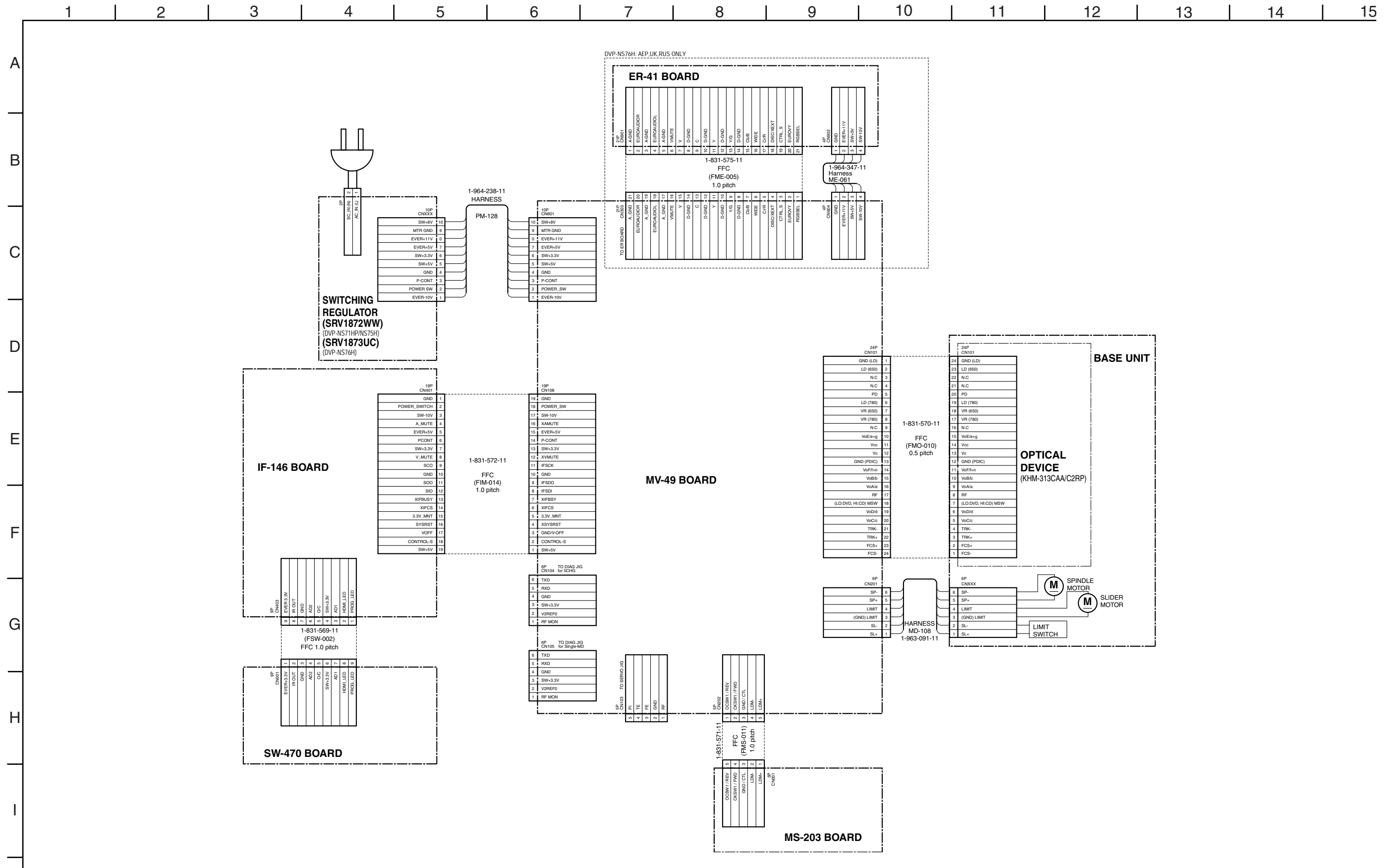

ER-41 (SCART) PRINTED WIRING BOARD

•  : Uses unleaded solder.

ER-41 BOARD (SIDE A)

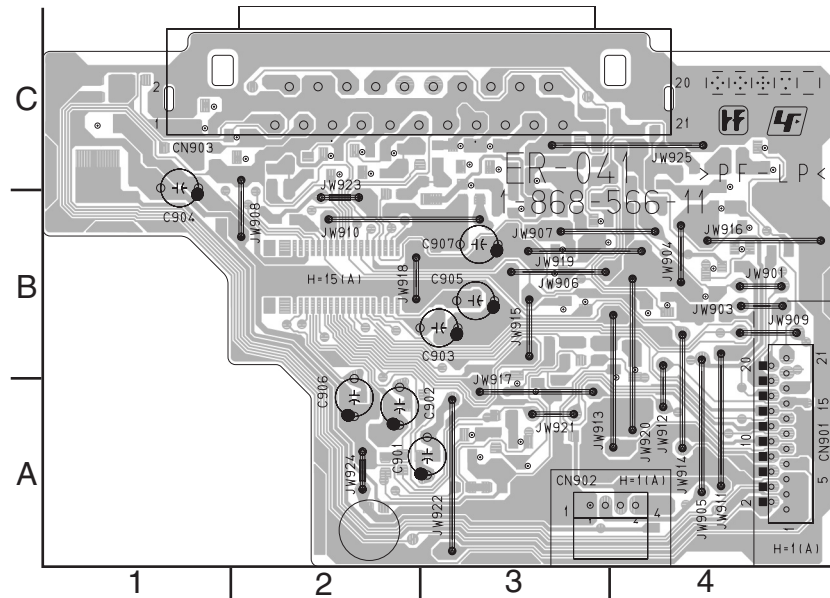

ER-41 BOARD (SIDE B)

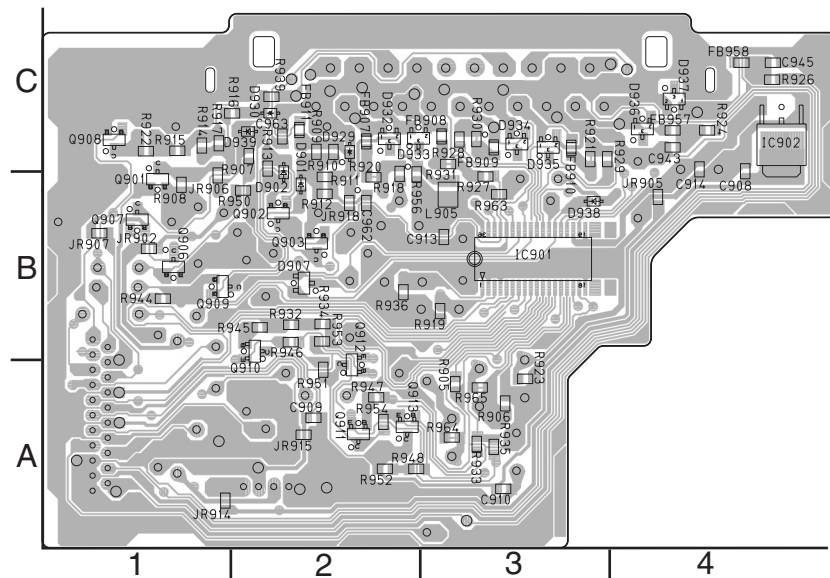

For printed wiring board

There are a few cases that the part printed on this diagram isn't mounted in this model.

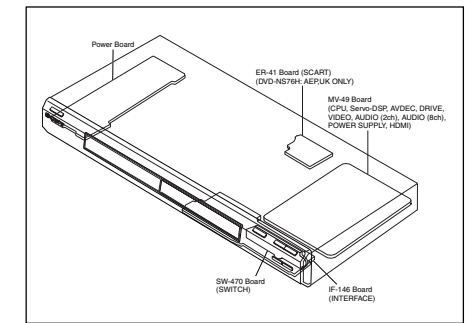

ER-41 BOARD

SIDE B

| | |
|-------|-----|
| IC901 | B-3 |
| IC902 | C-4 |
| | |
| Q901 | B-1 |
| Q902 | B-2 |
| Q903 | B-2 |
| Q906 | B-1 |
| Q907 | B-1 |
| Q908 | C-1 |
| Q909 | B-1 |
| Q910 | B-2 |
| Q911 | A-2 |
| Q912 | A-2 |
| Q913 | A-2 |
| | |
| D901 | B-2 |
| D902 | B-2 |
| D907 | B-2 |
| D929 | C-2 |
| D930 | C-2 |
| D932 | C-2 |
| D933 | C-2 |
| D934 | C-3 |
| D935 | C-3 |
| D936 | C-4 |
| D937 | C-4 |
| D938 | B-3 |
| D939 | C-2 |

For Schematic Diagram

- Refer to page 4-5 for printed wiring board of ER-41 board.
- Refer to page 4-4 for waveform

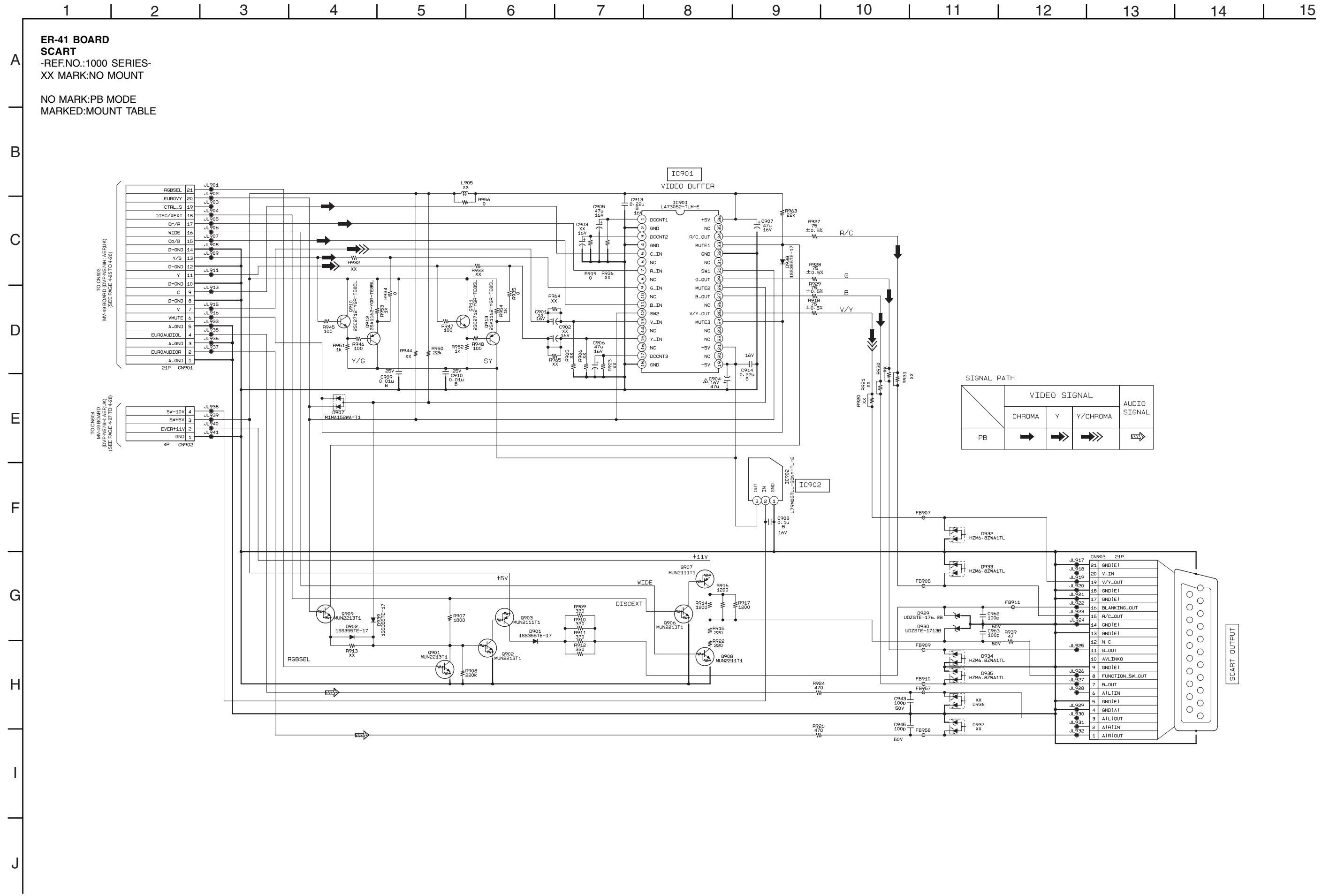

IF-146 (INTERFACE) PRINTED WIRING BOARD

•  : Uses unleaded solder.

IF-146 BOARD (SIDE A)

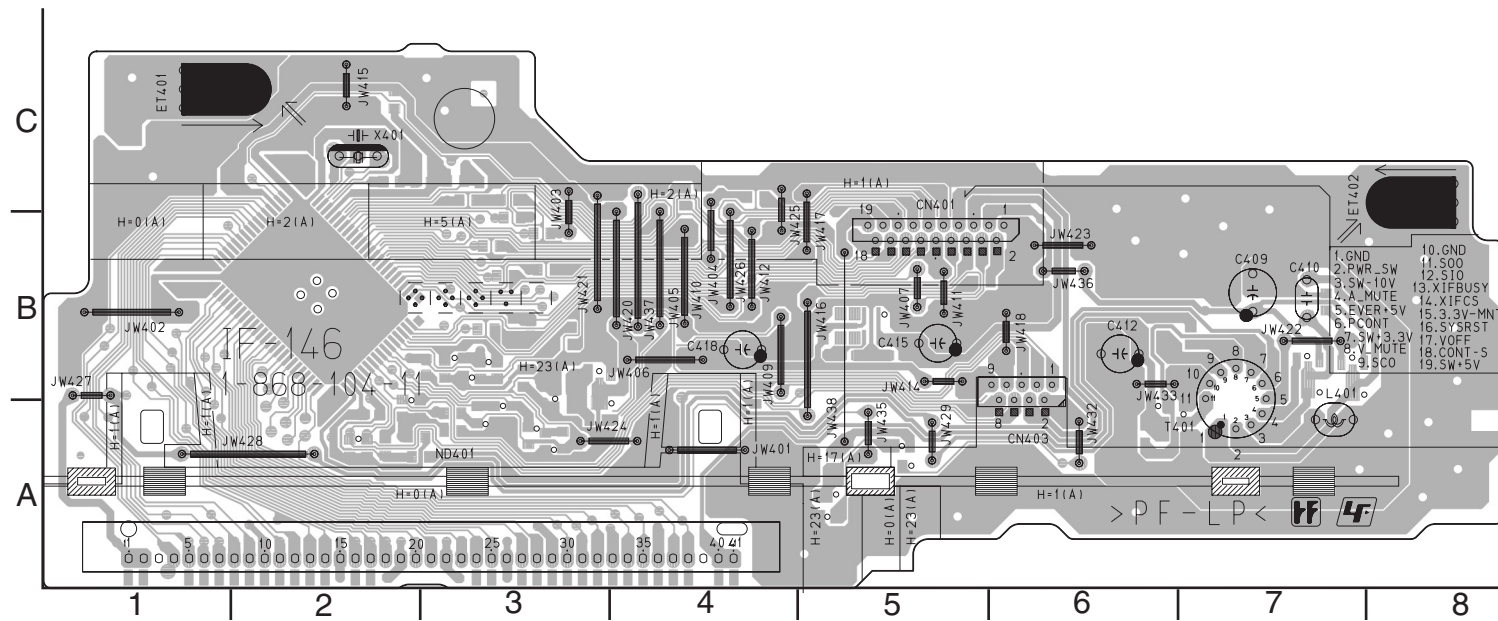

For printed wiring board

There are a few cases that the part printed on this diagram isn't mounted in this model.

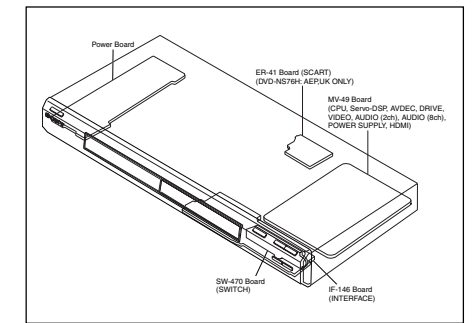

IF-146 BOARD

SIDE B

- IC404 B-7
- IC407 B-4
- IC408 B-5

- Q401 B-1
- Q402 B-2
- Q404 A-4
- Q405 A-4

- D402 B-2
- D403 A-2
- D406 A-2

IF-146 BOARD (SIDE B)

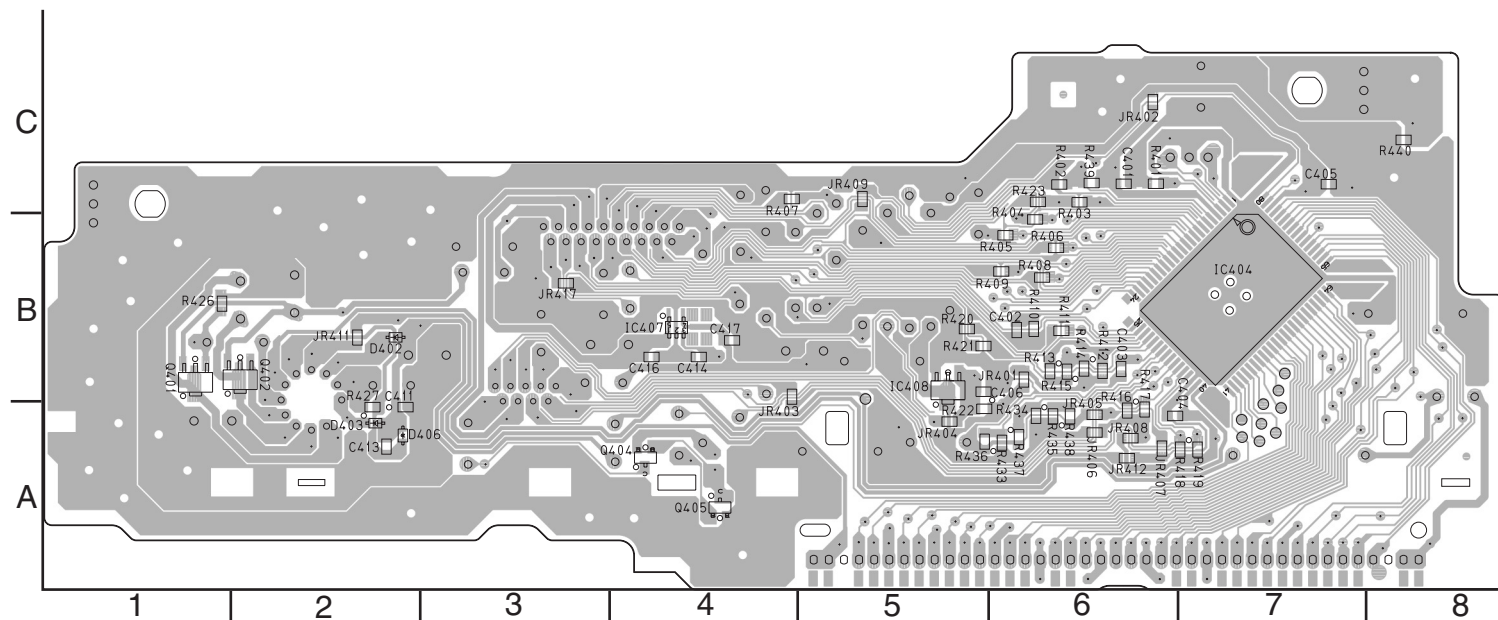

MS-203 (LOADING MOTOR) PRINTED WIRING BOARD

•  : Uses unleaded solder.

MS-203 BOARD

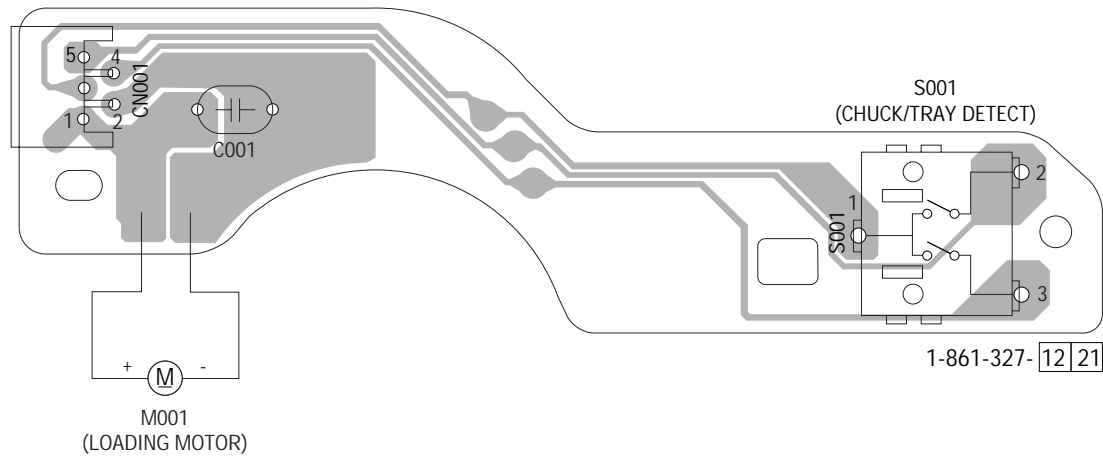

For printed wiring board

There are a few cases that the part printed on this diagram isn't mounted in this model.

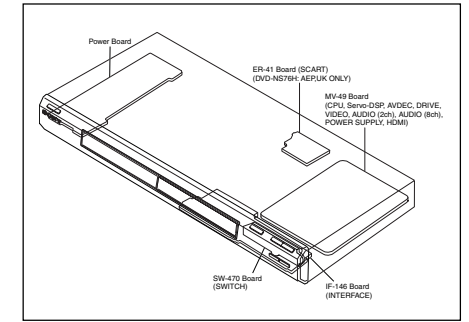

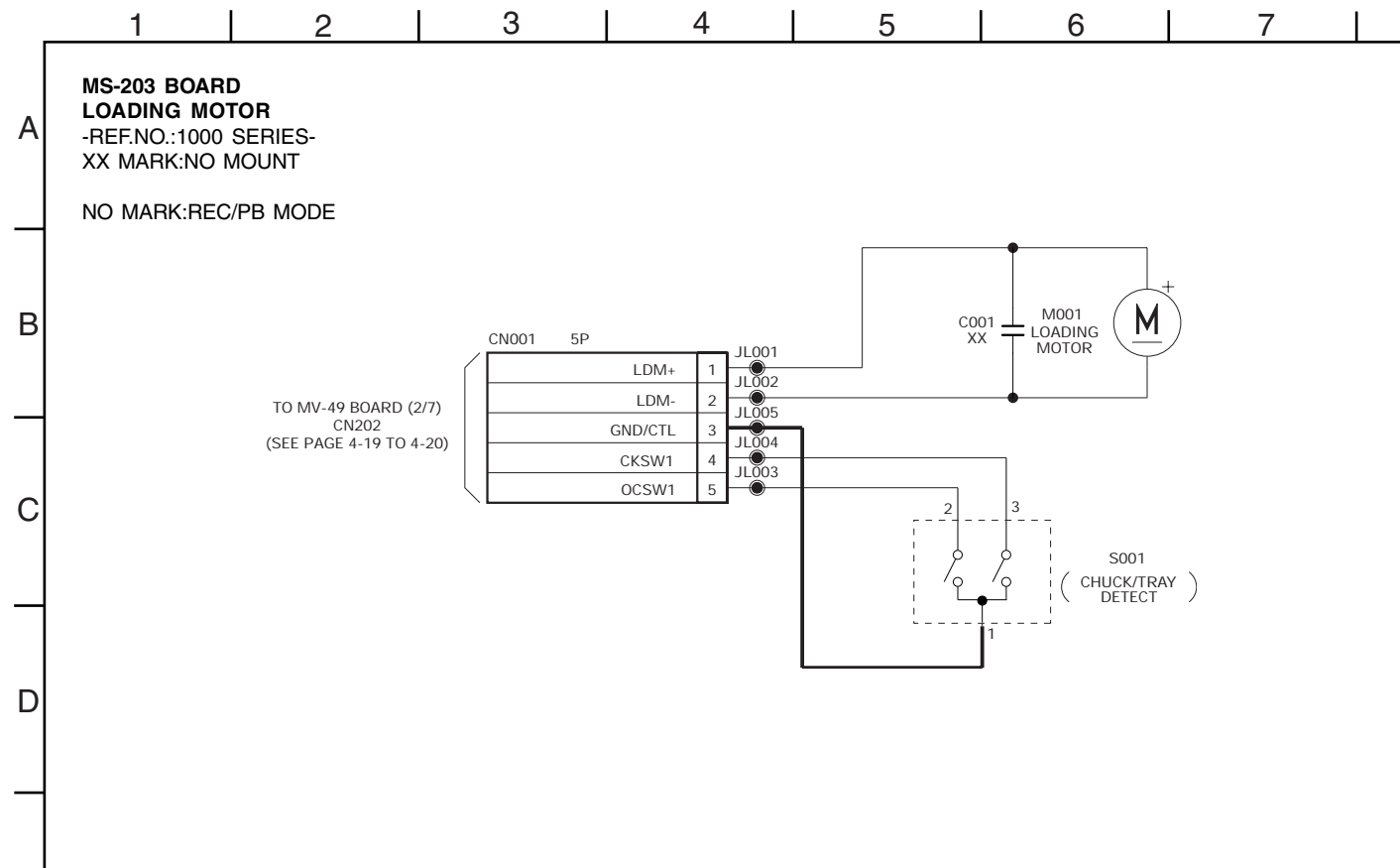

For Schematic Diagram

• Refer to page 4-13 for printed wiring board of MS-203 board.

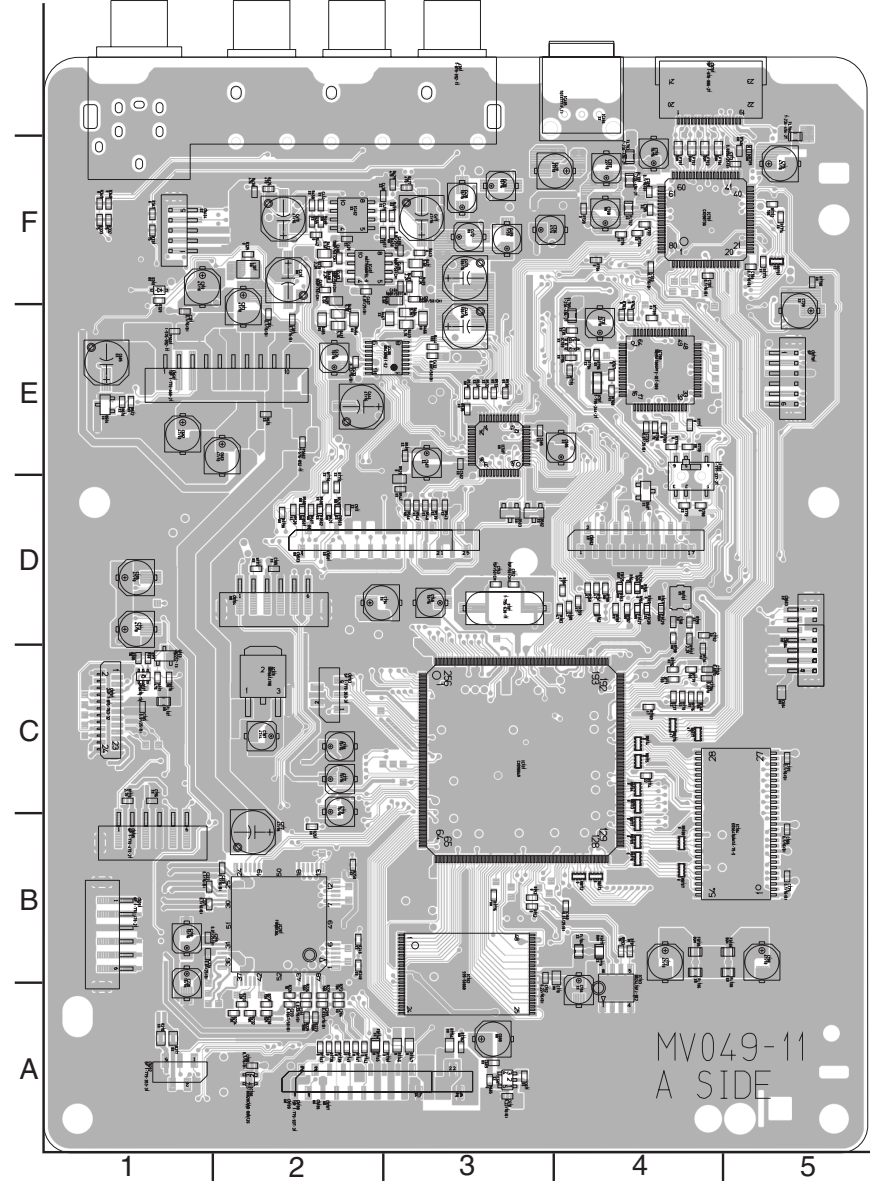

MV-49 (CPU, Servo-DSP, AVDEC, DRIVE, VIDEO, AUDIO (2ch), AUDIO (8ch), POWER SUPPLY, HDMI) PRINTED WIRING BOARD
MV-49 BOARD (SIDE A)



•  : Uses unleaded solder.

MV-49 BOARD (SIDE B)

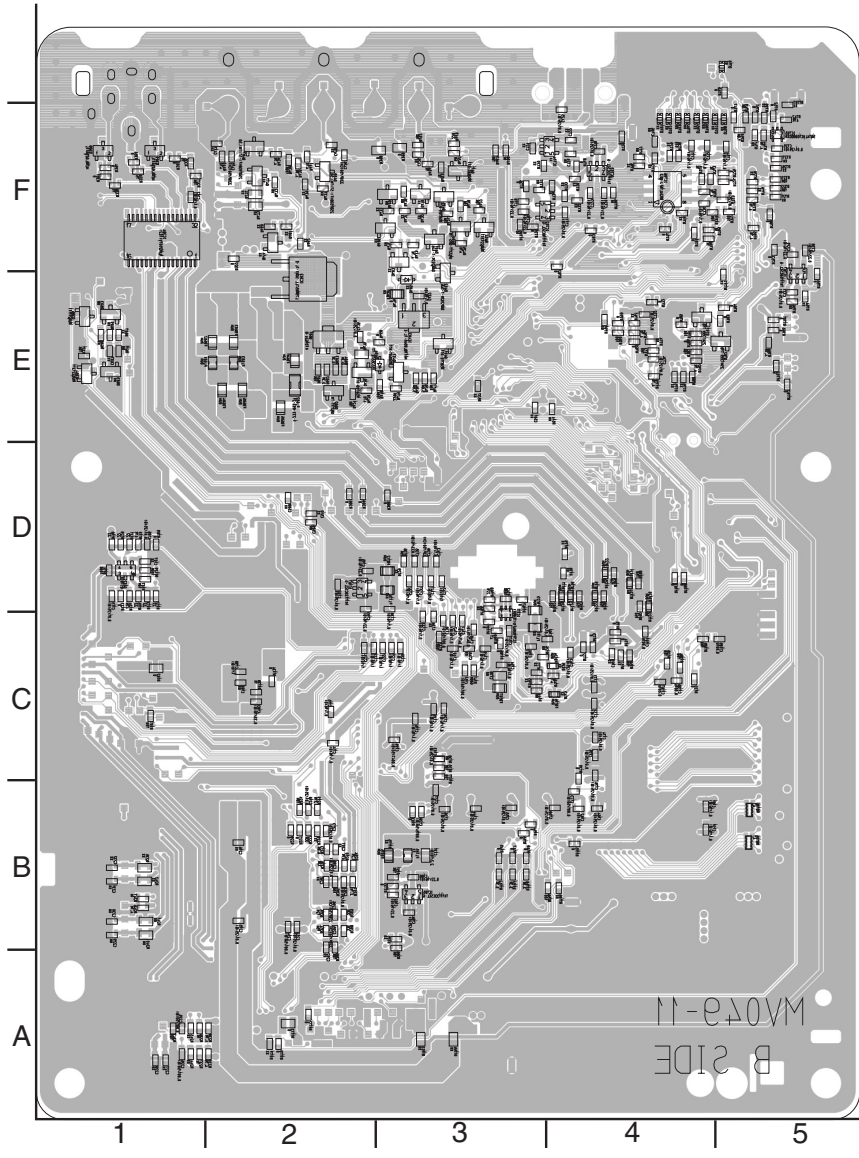

For printed wiring board

There are a few cases that the part printed on this diagram isn't mounted in this model.

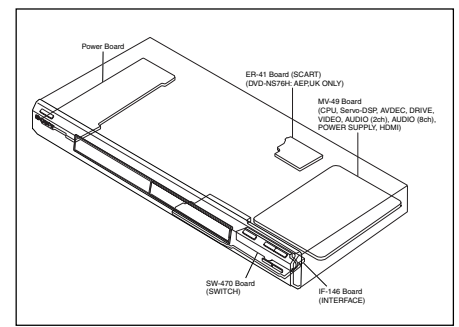

MV-49 BOARD

| SIDE A | | SIDE B | |
|--------|-----|--------|-----|
| IC101 | C-3 | IC105 | B-3 |
| IC102 | A-3 | IC107 | D-2 |
| IC104 | B-5 | IC111 | C-3 |
| IC108 | A-2 | IC303 | E-2 |
| IC110 | C-2 | IC304 | F-1 |
| IC201 | B-2 | IC403 | E-3 |
| IC401 | F-2 | IC702 | F-4 |
| IC405 | G-4 | IC703 | F-4 |
| IC406 | E-3 | IC705 | F-5 |
| IC701 | F-4 | IC706 | F-4 |
| IC708 | E-4 | IC707 | E-5 |
| Q101 | C-1 | Q102 | D-1 |
| Q103 | C-1 | Q304 | E-1 |
| | | Q305 | E-1 |
| | | Q401 | F-3 |
| | | Q402 | F-3 |
| | | Q403 | F-3 |
| | | Q404 | F-3 |
| | | Q405 | F-3 |
| | | Q407 | F-2 |
| | | Q408 | F-2 |
| | | Q411 | F-3 |
| | | Q416 | E-2 |
| | | Q601 | E-2 |
| | | Q602 | E-2 |
| | | Q701 | E-4 |
| | | Q702 | E-5 |
| | | D308 | F-1 |
| | | D309 | F-1 |
| | | D401 | F-3 |
| | | D402 | E-3 |
| | | D404 | E-3 |

For Schematic Diagram

- Refer to page 4-15 for printed wiring board of MV-49 board.
- Refer to page 4-4 for waveform

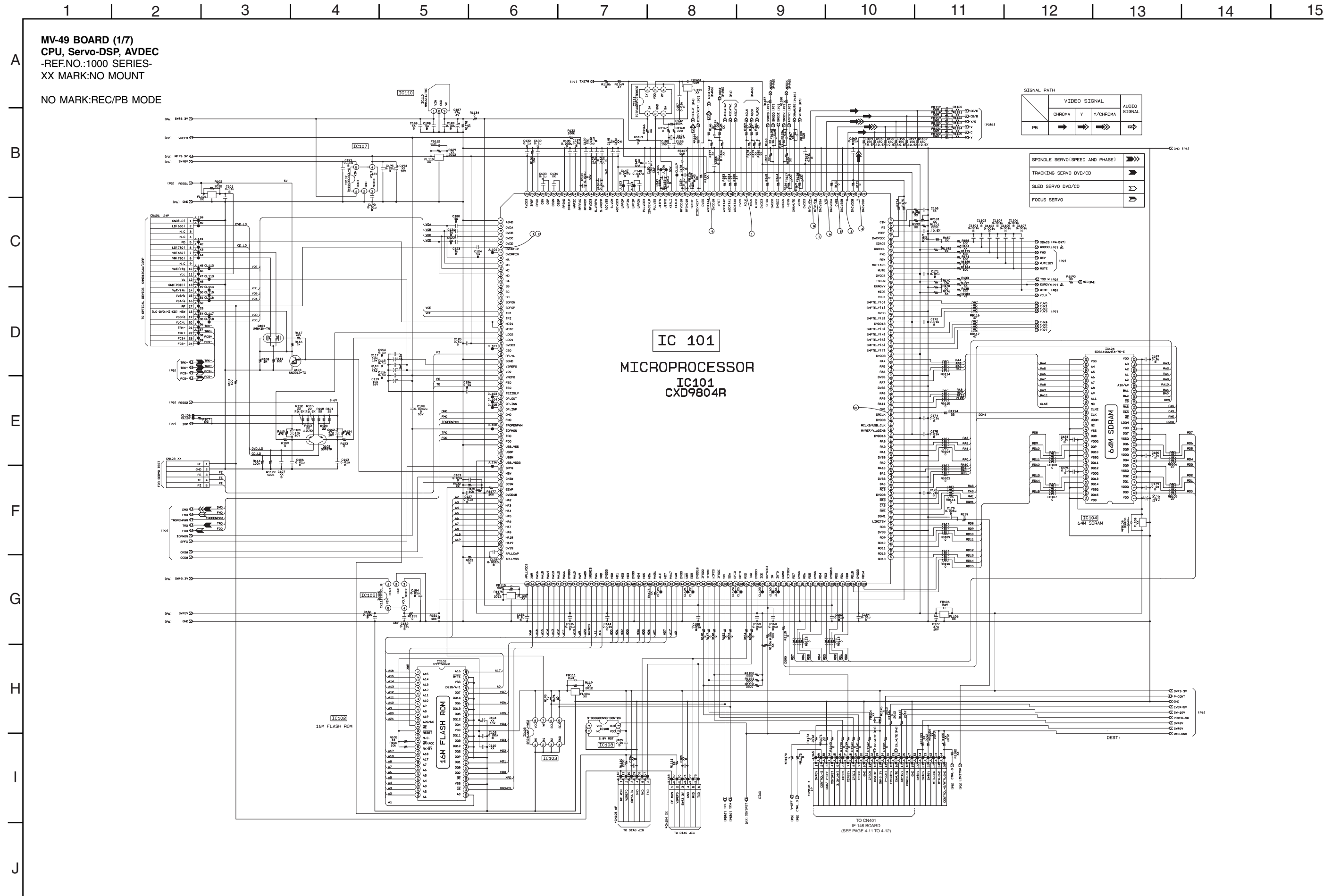

For Schematic Diagram

- Refer to page 4-15 for printed wiring board of MV-49 board.
- Refer to page 4-4 for waveform

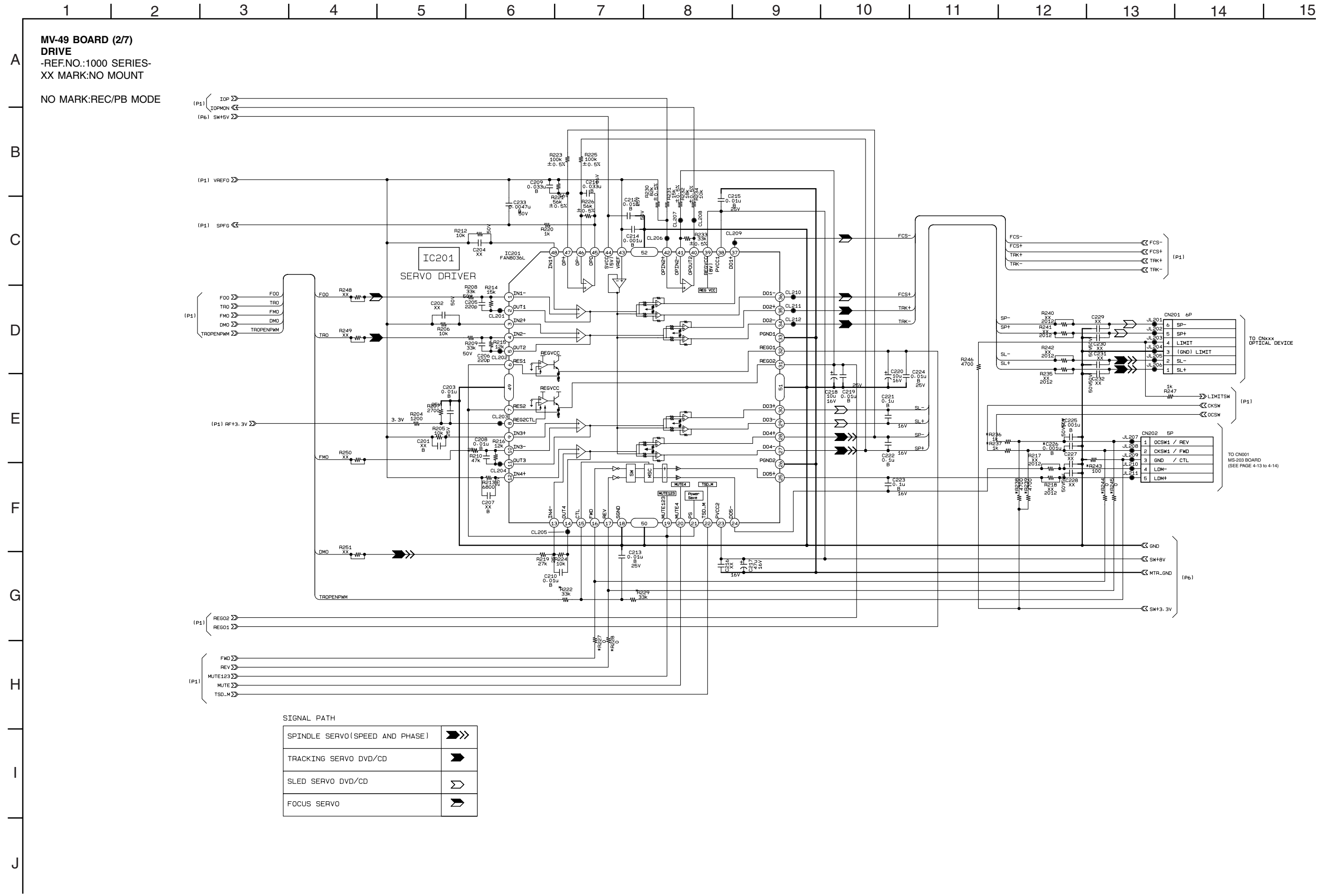

For Schematic Diagram

- Refer to page 4-15 for printed wiring board of MV-49 board.
- Refer to page 4-4 for waveform

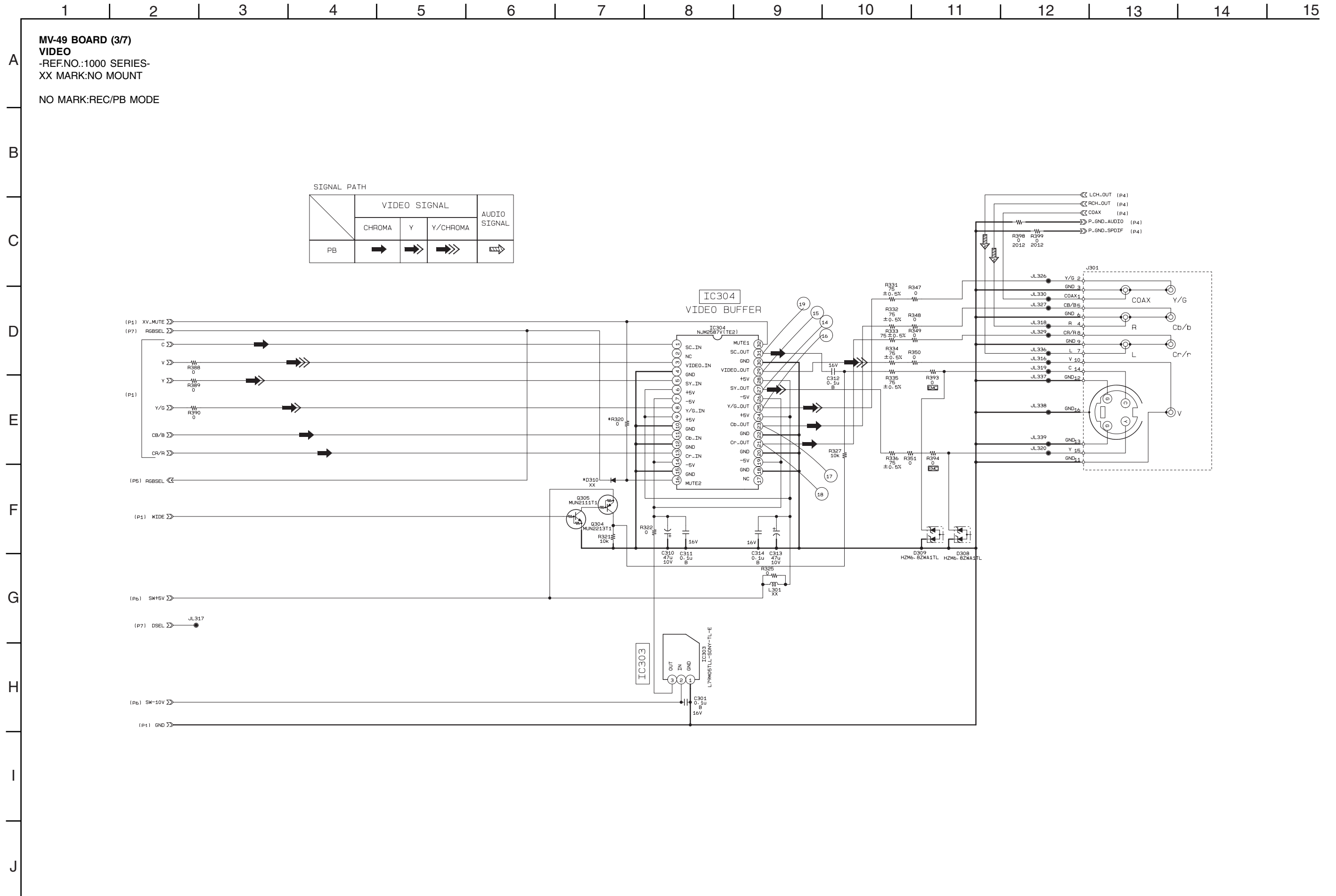

For Schematic Diagram

- Refer to page 4-15 for printed wiring board of MV-49 board.
- Refer to page 4-4 for waveform

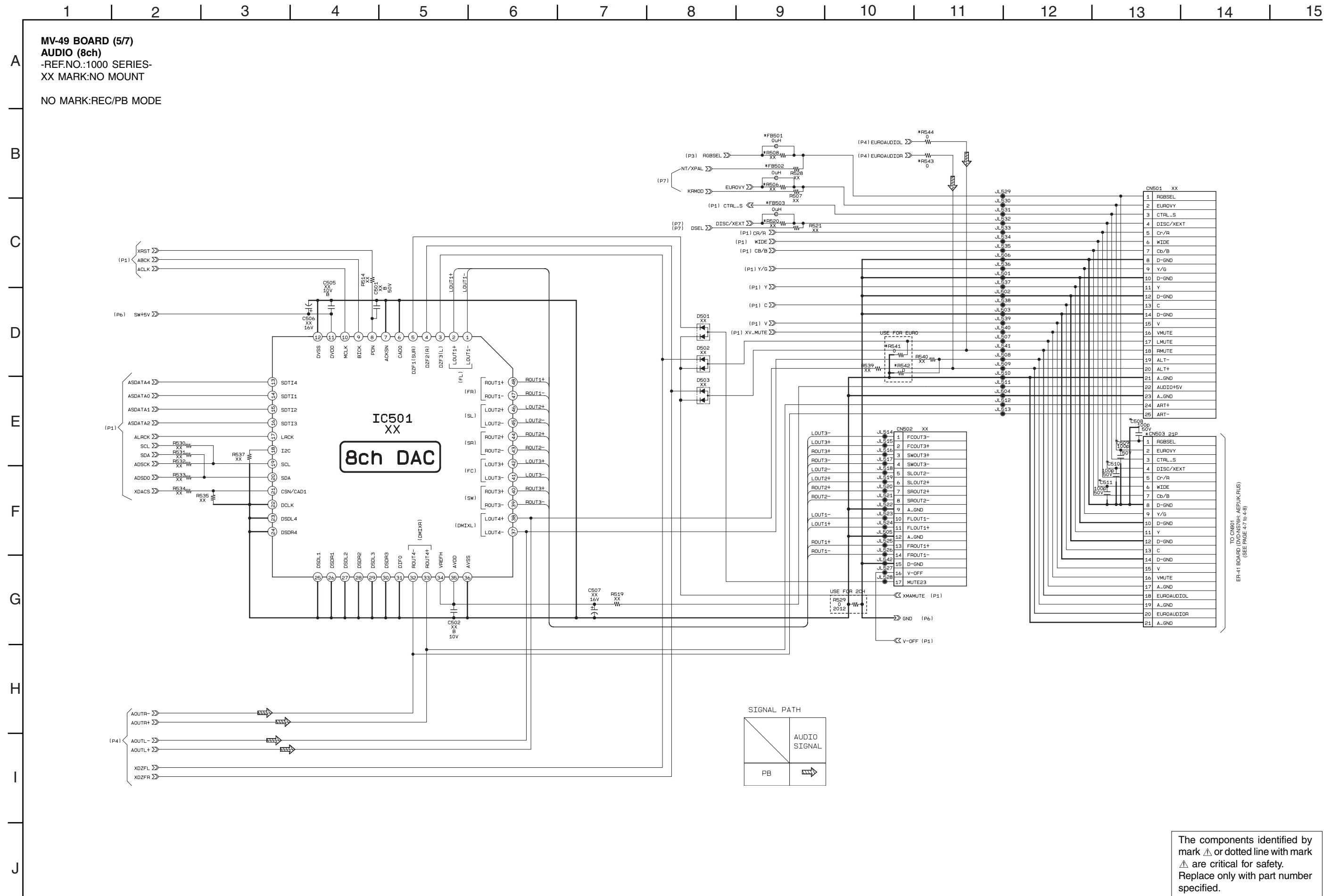

The components identified by mark Δ or dotted line with mark Δ are critical for safety. Replace only with part number specified.

For Schematic Diagram

- Refer to page 4-15 for printed wiring board of MV-49 board.
- Refer to page 4-4 for waveform

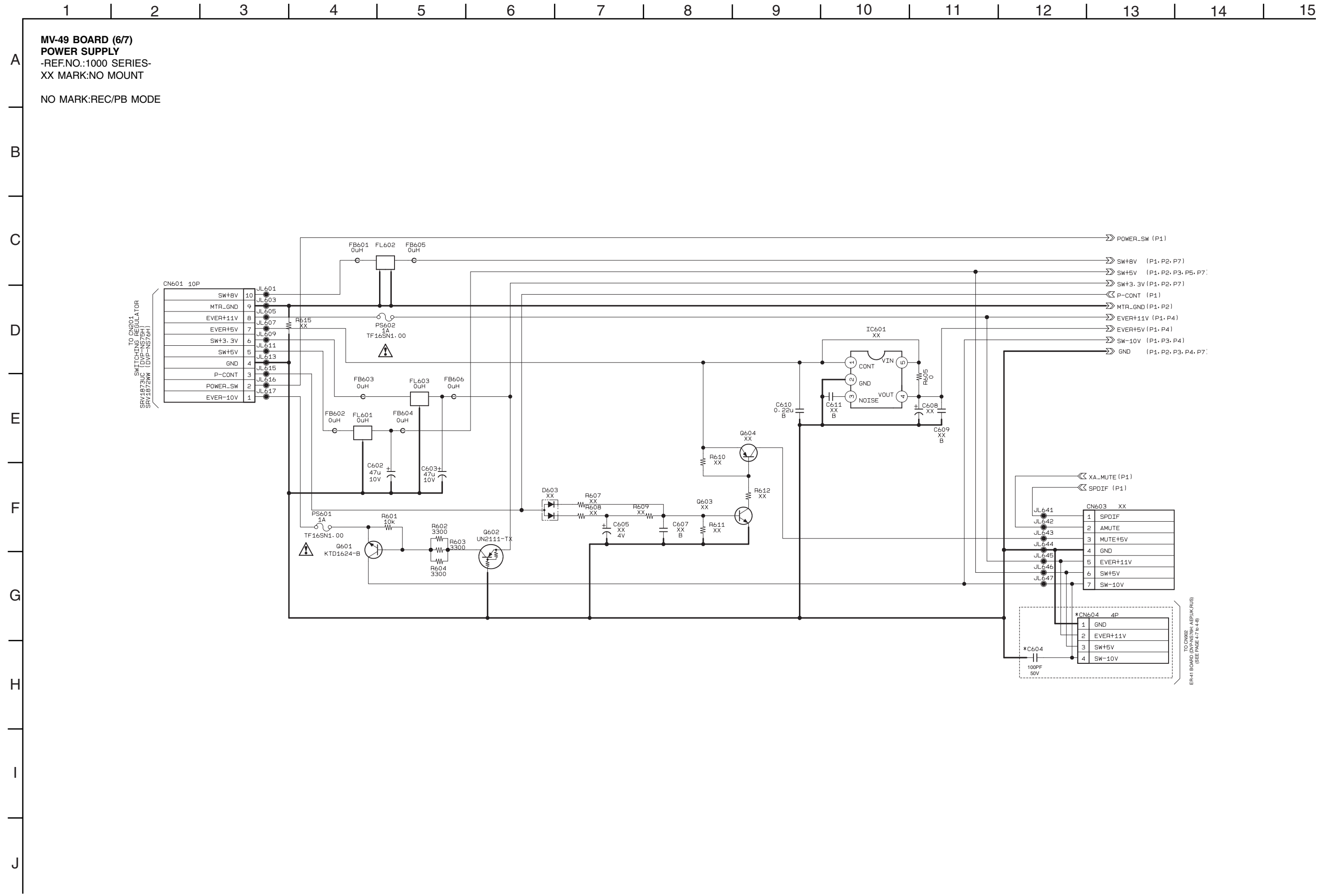

For Schematic Diagram

- Refer to page 4-15 for printed wiring board of MV-49 board.
- Refer to page 4-4 for waveform

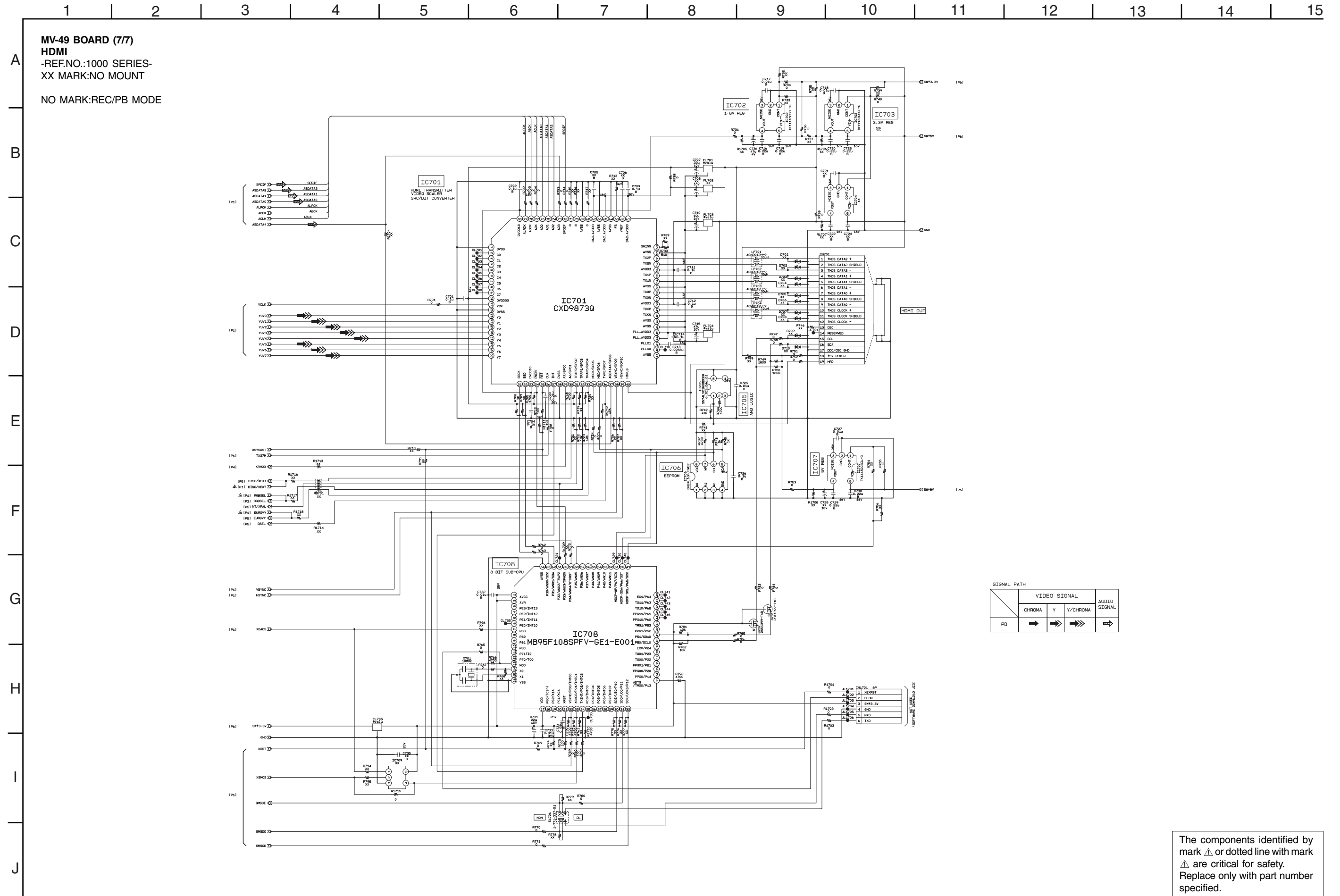

SW-470 (SWITCH) PRINTED WIRING BOARD

SW-470 BOARD (SIDE A)

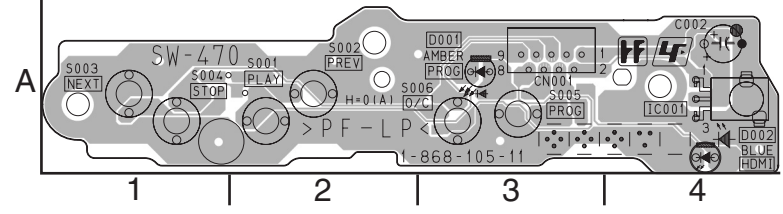

• : Uses unleaded solder.

SW-470 BOARD (SIDE B)

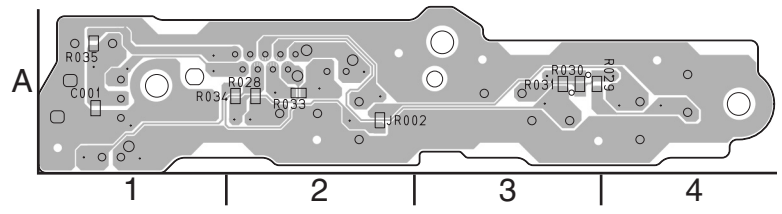

For printed wiring board

There are a few cases that the part printed on this diagram isn't mounted in this model.

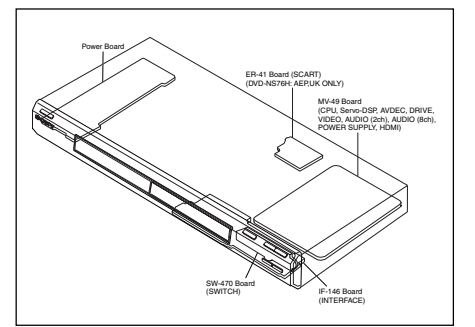

SW-470 BOARD SIDE A

- IC001 A-4
- D001 A-3

For Schematic Diagram

• Refer to page 4-31 for printed wiring board of SW-470 board.

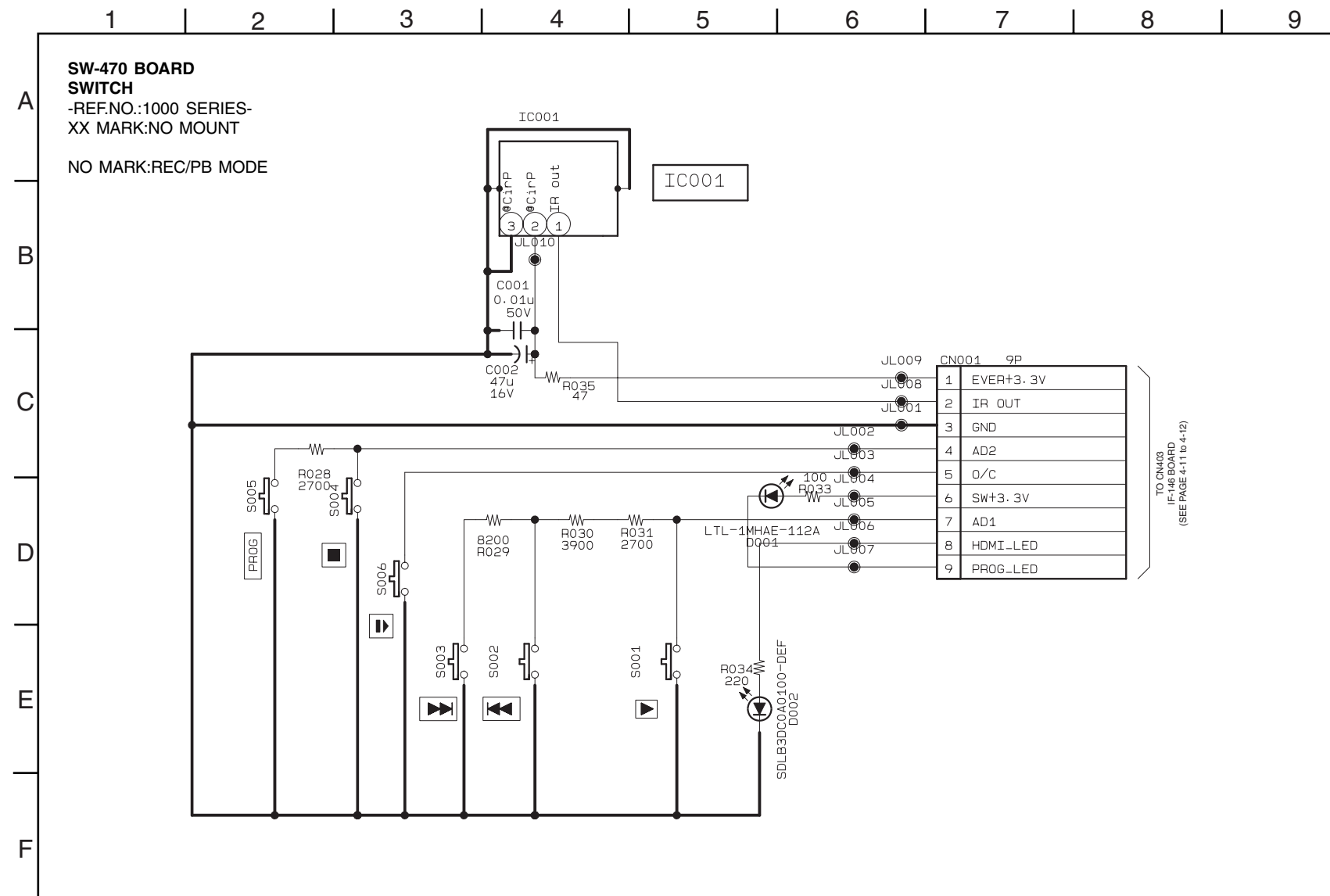

For Schematic Diagram

• Refer to page 4-33 for printed wiring board of Power board.

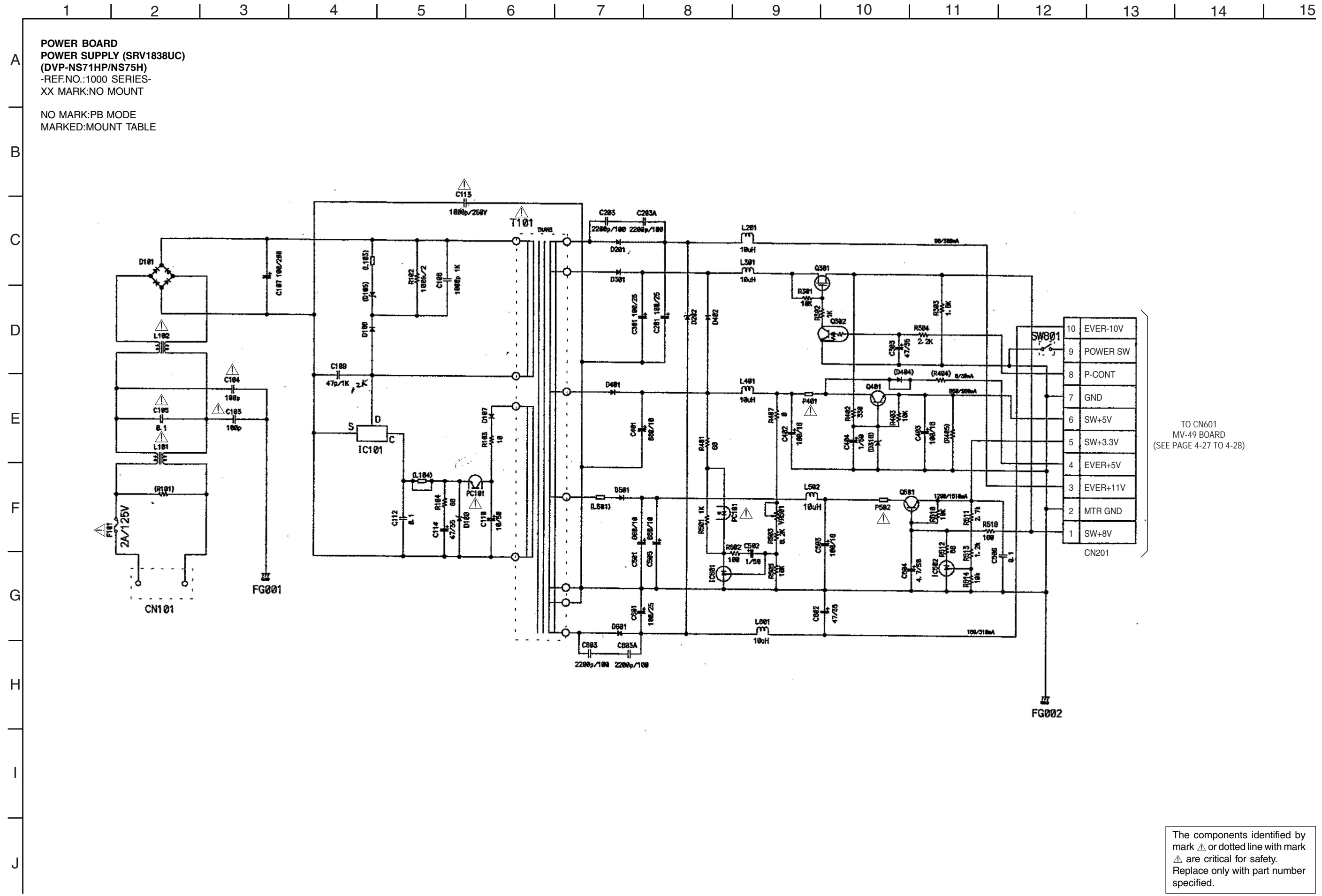

POWER BOARD
POWER SUPPLY (SRV1838UC)
 (DVP-NS71HP/NS75H)
 -REF.NO.:1000 SERIES-
 XX MARK:NO MOUNT

NO MARK:PB MODE
 MARKED:MOUNT TABLE

| | |
|----|----------|
| 10 | EVER-10V |
| 9 | POWER SW |
| 8 | P-CONT |
| 7 | GND |
| 6 | SW+5V |
| 5 | SW+3.3V |
| 4 | EVER+5V |
| 3 | EVER+11V |
| 2 | MTR GND |
| 1 | SW+8V |

CN201

TO CN601
 MV-49 BOARD
 (SEE PAGE 4-27 TO 4-28)

The components identified by mark \triangle or dotted line with mark \triangle are critical for safety. Replace only with part number specified.

POWER BLOCK (SRV1839WW) PRINTED WIRING BOARD

•  : Uses unleaded solder.

POWER BOARD (SRV1839WW) (SIDE A)
(DVP-NS76H)

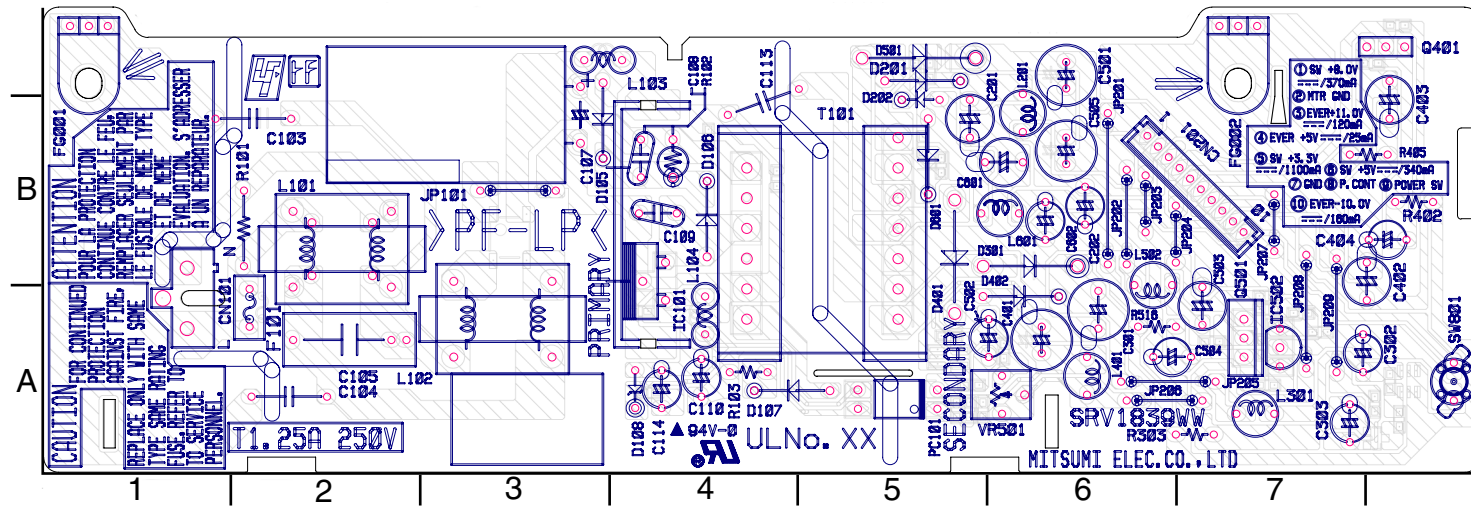

For printed wiring board

There are a few cases that the part printed on this diagram isn't mounted in this model.

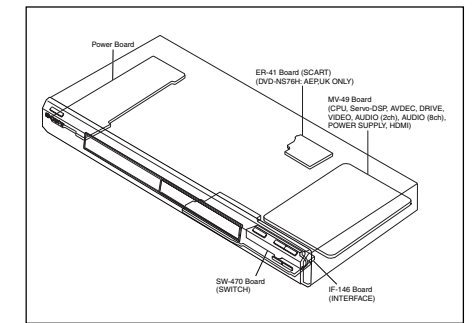

POWER BOARD (SRV1839WW)

SIDE A

- IC101 A-4
- IC502 A-7
- Q401 C-8
- Q501 A-7
- D105 B-3
- D106 B-4
- D107 A-4
- D108 A-4
- D201 C-5
- D202 B-5
- D301 B-6
- D401 A-5
- D402 A-6
- D501 C-5
- D601 B-5

SIDE B

- IC501 A-3
- Q301 A-1
- Q302 A-1
- D101 B-6

POWER BOARD (SRV1839WW) (SIDE B)
(DVP-NS76H)

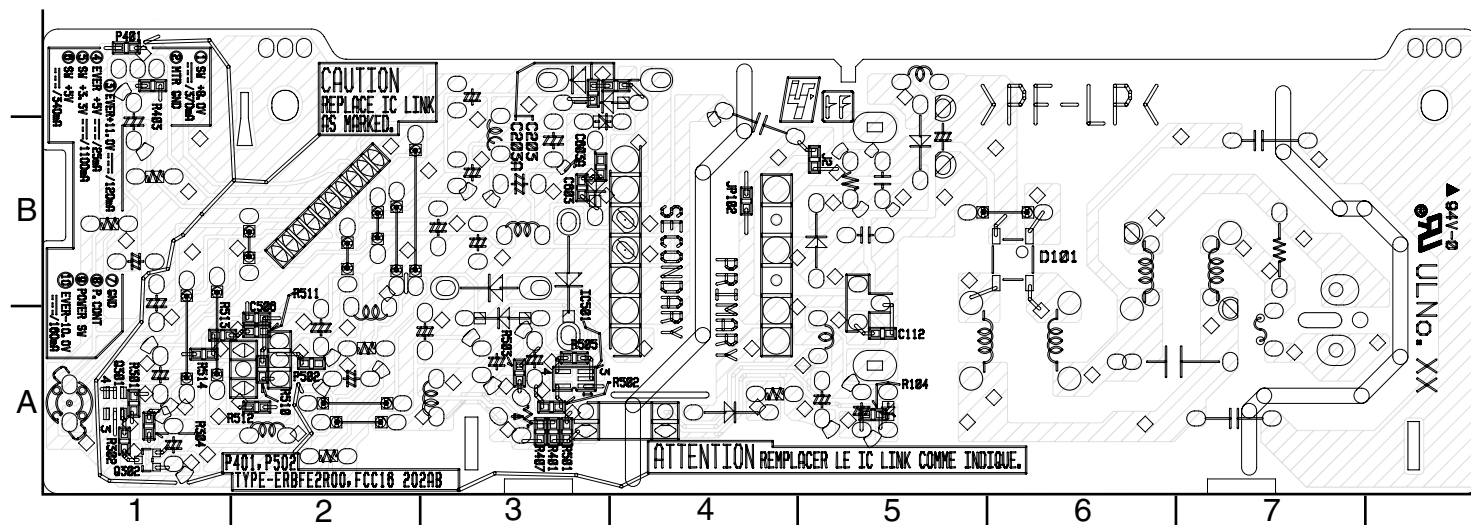

For Schematic Diagram

• Refer to page 4-37 for printed wiring board of Power board.

1 2 3 4 5 6 7 8 9 10 11 12 13 14 15

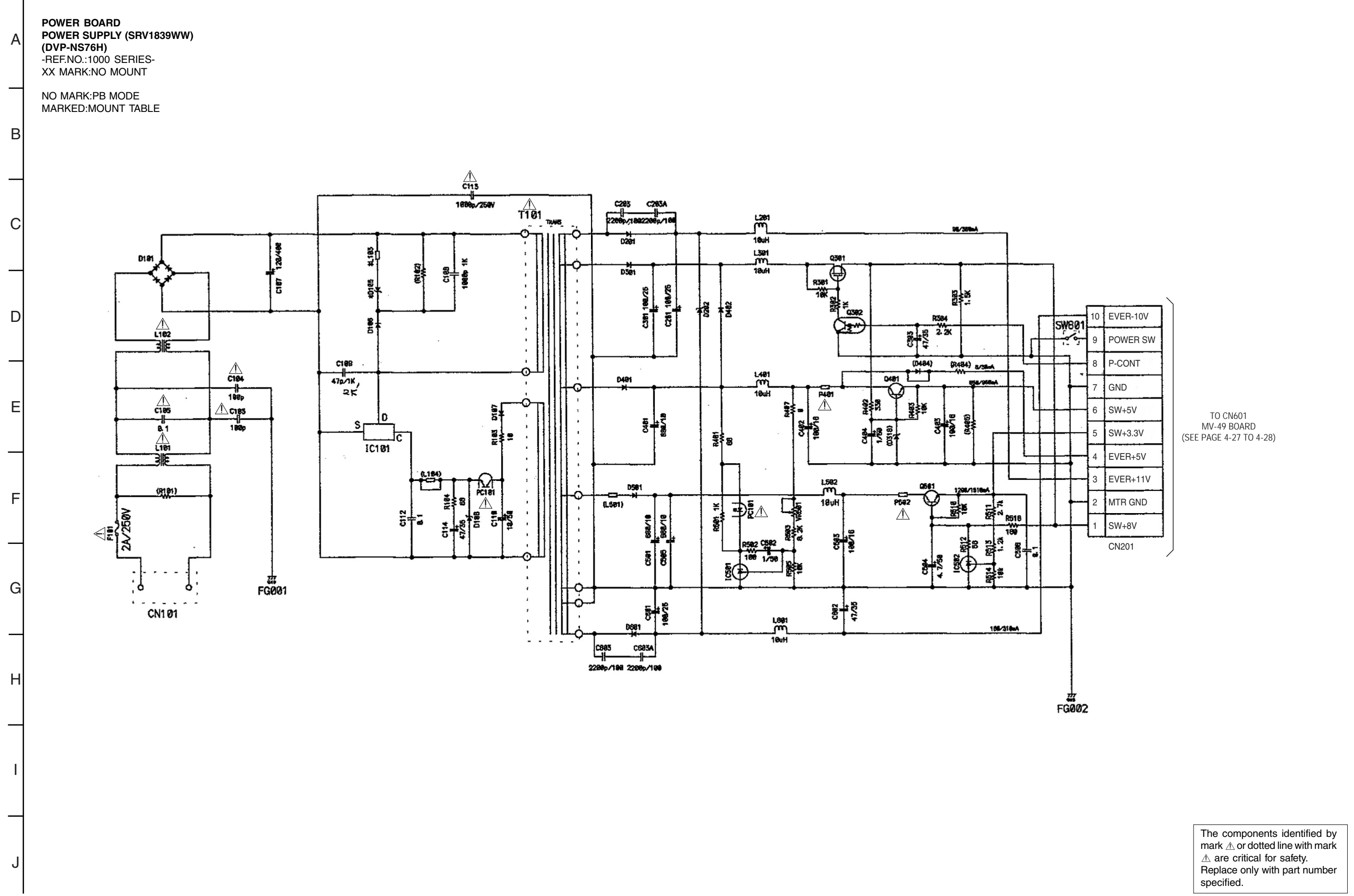

SECTION 5

IC PIN FUNCTION DESCRIPTION

5-1. SYSTEM CONTROL PIN FUNCTION (MV-49 BOARD IC101)

| Pin No. | Pin name | Type | Function |
|---------|-----------|----------------------|---|
| 1 | AGND | | Ground pin for analog circuitry |
| 2 | DVDA | Analog Input | AC coupled input path A |
| 3 | DVDB | Analog Input | AC coupled input path B |
| 4 | DVDC | Analog Input | AC coupled input path C |
| 5 | DVDD | Analog Input | AC coupled input path D |
| 6 | DVDRFIP | Analog Input | AC coupled DVD RF signal input RFIP |
| 7 | DVDRFIN | Analog Input | AC coupled DVD RF signal input RFIN |
| 8 | MA | Analog Input | DC coupled main-beam RF signal input A |
| 9 | MB | Analog Input | DC coupled main-beam RF signal input B |
| 10 | MC | Analog Input | DC coupled main-beam RF signal input C |
| 11 | MD | Analog Input | DC coupled main-beam RF signal input D |
| 12 | SA | Analog Input | DC coupled sub-beam RF signal input A |
| 13 | SB | Analog Input | DC coupled sub-beam RF signal input B |
| 14 | SC | Analog Input | DC coupled sub-beam RF signal input C |
| 15 | SD | Analog Input | DC coupled sub-beam RF signal input D |
| 16 | SDFON | Analog Input | CD focusing error negative input |
| 17 | SDFOP | Analog Input | CD focusing error positive input |
| 18 | TNI | Analog Input | 3 beam satellite PD signal negative input |
| 19 | TPI | Analog Input | 3 beam satellite PD signal positive input |
| 20 | MDI1 | Analog Input | Laser power monitor input |
| 21 | MDI2 | Analog Input | Laser power monitor input |
| 22 | LDO2 | Analog Output | Laser driver output |
| 23 | LDO1 | Analog Output | Laser driver output |
| 24 | SVDD3 | Power | Analog 3.3V power |
| 25 | CSO | Analog Output | Central servo |
| 26 | RFLVL | Analog Output | RFRP low pass output |
| 27 | SGND | Ground | Ground pin for analog circuitry |
| 28 | V2REFO | Analog Output | Reference voltage 2.8V |
| 29 | V20 | Analog Output | Reference voltage 2.0V |
| 30 | VREFO | Analog Output | Reference voltage 1.4V |
| 31 | FEO | Analog Output | Focus error monitor output |
| 32 | TEO | Analog Output | Tracking error monitor output |
| 33 | TEZISLV | Analog Output | TE Slicing Level |
| 34 | OP_OUT | Analog Output | OP amp output |
| 35 | OP_INN | Analog Input | OP amp negative input |
| 36 | OP_INP | Analog Input | OP amp positive input |
| 37 | DMO | Analog Output | Disc motor control output. PWM output |
| 38 | FMO | Analog Output | Feed motor control. PWM output |
| 39 | TROPENPWM | Analog Output | Tray PWM output/Tray open output |
| 40 | IOPMON | Analog Input | IOP Monitor |
| 41 | TRO | Analog Output | PDM output of tracking servo compensator |
| 42 | FOO | Analog Output | PDM output of focus servo compensator |
| 43 | USB_VSS | Ground | Ground pin for USB |
| 44 | NC | | Not used |
| 45 | NC | | Not used |
| 46 | USB_VDD3 | Power Input LVTTL | 3.3V power pin for USB |
| 47 | SPFG | 3.3 V, SMT,PU | General A/D input -> Iop Monitor |

DVP-NS71HP/NS75H/NS76H

| Pin No. | Pin name | Type | Function |
|---------|----------|-------------------------------|---|
| 48 | MSW | Analog Output | Laser Mode SW(H: DVD L: CD) |
| 49 | CKSW | Analog Input | Disc chucking SW sensor |
| 50 | OCSW | Input | Open Close Switch |
| 51 | EEWP | Output | EEPROM write Protect Control (L: write allowed) |
| 52 | DVDD18 | Power | 1.8V power pin for internal digital circuitry |
| 53 | HA2 | Output PU | Host address bit2 |
| 54 | HA3 | Output PU | Host address bit3 |
| 55 | HA4 | Output PU | Host address bit4 |
| 56 | HA5 | Output PU | Host address bit5 |
| 57 | HA6 | Output PU | Host address bit6 |
| 58 | HA7 | Output PU | Host address bit7 |
| 59 | HA8 | Output PU | Host address bit8 |
| 60 | HA18 | Output SMT | Host address bit18 |
| 61 | HA19 | Output SMT | Host address bit19 |
| 62 | DVSS | Ground | Ground pin for internal digital circuitry |
| 63 | APLLCAP | Analog Input | APLL External Capacitance connection |
| 64 | APLLVSS | Ground | Ground pin for audio clock circuitry |
| 65 | APLLVDD3 | Power | 3.3V power for audio clock circuitry |
| 66 | xWR | Output SMT | Write enable, active Low |
| 67 | HA16 | Output | Host address bit16 |
| 68 | HA15 | Output PU | Host address bit15 |
| 69 | HA14 | Output PU | Host address bit14 |
| 70 | HA13 | Output PU | Host address bit13 |
| 71 | HA12 | Output PU | Host address bit12 |
| 72 | HA11 | Output PU | Host address bit11 |
| 73 | DVDD3 | Power | 3.3V power pin for internal digital circuitry |
| 74 | HA10 | Output PU | Host address bit10 |
| 75 | HA9 | Output PU | Host address bit9 |
| 76 | HA20 | Output SMT | Host address bit20 |
| 77 | xROMCS | Output PU, SMT | Chip select, active Low |
| 78 | HA1 | Output PU | Host address bit1 |
| 79 | xRD | Output SMT | Read enable, active Low |
| 80 | DVDD3 | Power | 3.3V power pin for internal digital circuitry |
| 81 | HD0 | Output | Host data bit0 |
| 82 | HD1 | Output | Host data bit1 |
| 83 | HD2 | Output | Host data bit2 |
| 84 | HD3 | Output | Host data bit3 |
| 85 | DVSS | Ground | Ground pin for internal digital circuitry |
| 86 | HD4 | Output | Host data bit4 |
| 87 | HD5 | Output | Host data bit5 |
| 88 | HD6 | Output | Host data bit6 |
| 89 | HA21 | Output SMT | Host address bit21 |
| 90 | NC | | Not used |
| 91 | HD7 | Output | Host data bit7 |
| 92 | HA17 | Output | Host address bit17 |
| 93 | HA0 | Output PU | Host address bit0 |
| 94 | DVSS | Ground | Ground pin for internal digital circuitry |
| 95 | NC | | Not used |
| 96 | NC | | Not used |
| 97 | DVDD18 | Power Output PU,SMT | 1.8V power pin for internal digital circuitry |
| 98 | IFSDO | Default High Output PU,SMT | Ext. CPU Serial data output (H/W method) |
| 99 | IFCK | Default High Output PU,SMT | Ext. CPU Serial clock (H/W method) |

| Pin No. | Pin name | Type | Function |
|---------|----------|-------------------------------|--|
| 100 | xIFCS | Default High | Chip select for Ext.CPU (Low Active, H/W method) |
| 101 | IFSDI | Input SMT Output PU,SMT | Ext. CPU Serial data Input (H/W method) |
| 102 | SCL | Default High Output PU,SMT | IIC clock pin |
| 103 | SDA | Default High Output PU,SMT | IIC data pin |
| 104 | HDMI-SCL | Fixed Low | HDMI-DDC IIC Clock Pin |
| 105 | HDMI-SPA | Fixed Low | HDMI-DDC Data Pin |
| 106 | RXD | Input PU,SMT Output PU,SMT | Hardwired RS232C RXD |
| 107 | TXD | Default High | Hardwired RS232C TXD |
| 108 | DVDD3 | Power | 3.3V power pin for internal digital circuitry |
| 109 | ICE | Output PU,SMT | Ice mode enable |
| 110 | xSYSRST | Input PU,SMT | MT1389 reset input, active Low |
| 111 | NC | | Not Used |
| 112 | xTXINT | PU,SMT | 8032 external interrupt 0 (for MT1392) |
| 113 | DQM0 | Output Output Default | Mask for DRAM input/output byte 0 |
| 114 | IFBSY | Input | Ext. CPU Ready/Busy interrupt signal (H: Busy, L: ready) |
| 115 | RD7 | Output | DRAM data bit7 |
| 116 | DVSS | Ground | Ground pin for internal digital circuitry |
| 117 | RD6 | Output | DRAM data bit6 |
| 118 | RD5 | Output | DRAM data bit5 |
| 119 | DVSS | Ground | Ground pin for internal digital circuitry |
| 120 | RD4 | Output | DRAM data bit4 |
| 121 | RD3 | Output | DRAM data bit3 |
| 122 | DVDD18 | Power | 1.8V power pin for internal digital circuitry |
| 123 | RD2 | Output | DRAM data bit2 |
| 124 | RD1 | Output | DRAM data bit1 |
| 125 | RD0 | Output | DRAM data bit0 |
| 126 | RD15 | Output | DRAM data bit15 |
| 127 | DVDD3 | Power | 3.3V power pin for internal digital circuitry |
| 128 | RD14 | Output | DRAM data bit14 |
| 129 | RD13 | Output | DRAM data bit13 |
| 130 | RD12 | Output | DRAM data bit12 |
| 131 | RD11 | Output | DRAM data bit11 |
| 132 | RD10 | Output | DRAM data bit10 |
| 133 | RD9 | Output | DRAM data bit9 |
| 134 | DVSS | Ground | Ground pin for internal circuitry |
| 135 | RD8 | Output Output Default | DRAM data bit8 |
| 136 | LIMITSW | Input | Inlimit SW sensor input signal |
| 137 | DQM1 | Output | Mask for DRAM input/output byte 1 |
| 138 | RWE# | Output | DRAM write enable |
| 139 | CAS# | Output | DRAM column address strobe |
| 140 | RAS# | Output | DRAM row address strobe |
| 141 | DVDD3 | Power | 3.3V power pin for internal digital circuitry |
| 142 | RCS# | Output | DRAM chip select |
| 143 | BA0 | Output | DRAM bank address 0 |
| 144 | DVSS | Ground | Ground pin for internal digital circuitry |
| 145 | BA1 | Output | DRAM bank address 1 |
| 146 | RA10 | Output | DRAM address bit10 |
| 147 | RA0 | Output | DRAM address bit0 |
| 148 | DVSS | Ground | Ground pin for internal digital circuitry |
| 149 | RA1 | Output | DRAM address bit1 |

| Pin No. | Pin name | Type | Function |
|---------|----------|-------------------------|---|
| 150 | RA2 | Output | DRAM address bit2 |
| 151 | RA3 | Output | DRAM address bit3 |
| 152 | DVDD18 | Power | 1.8V power pin for internal digital circuitry |
| 153 | NC | | Not used |
| 154 | NC | | Not used |
| 155 | DVDD3 | Power | 3.3V power pin for internal digital circuitry |
| 156 | DRCLK | Output | DRAM clock |
| 157 | CKE | Output | DRAM clock enable |
| 158 | RA11 | Output PD | DRAM address bit11 |
| 159 | RA9 | Output | DRAM address bit9 |
| 160 | RA8 | Output | DRAM address bit8 |
| 161 | DVSS | Ground | Ground pin for internal digital circuitry |
| 162 | RA7 | Output | DRAM address bit7 |
| 163 | DVSS | Ground | Ground pin for internal digital circuitry |
| 164 | RA6 | Output | DRAM address bit6 |
| 165 | RA5 | Output | DRAM address bit5 |
| 166 | RA4 | Output | DRAM address bit4 |
| 167 | DVDD3 | Power | 3.3V power pin for internal digital circuitry |
| 168 | SMPTE_Y7 | Output | Video data output bit 7 |
| 169 | SMPTE_Y6 | Output | Video data output bit 6 |
| 170 | SMPTE_Y5 | Output | Video data output bit 5 |
| 171 | SMPTE_Y4 | Output | Video data output bit 4 |
| 172 | SMPTE_Y3 | Output | Video data output bit 3 |
| 173 | DVDD18 | Power Output Default | 1.8V power pin for internal digital circuitry |
| 174 | SMPTE_Y2 | Output | Video data output bit 2 |
| 175 | DVSS | Ground | Ground pin for internal digital circuitry |
| 176 | SMPTE_Y1 | Output | Video data output bit 1 |
| 177 | SMPTE_Y0 | Output | Video data output bit 0 |
| 178 | TSD_M | Input PU | SERVO GPIO 3 |
| 179 | WIDE | Output PU | Voltage select output signal for S-terminal (H: 16:9, L: 4:3) |
| 180 | EUROVY | Output PD | CVBS/S terminal select output signal (H: CBVS, L: S-terminal) |
| 181 | TSD-M | Output PD | Thermal shutdown for motor driver |
| 182 | DVDD3 | Power | 3.3V power pin for internal digital circuitry |
| 183 | MUTE | Output PD | Servo driver mute signal |
| 184 | MUTE123 | Output PD | Servo driver mute signal |
| 185 | REV | Output PD | Loading control signal (Reverse) |
| 186 | FWD | Output PD | Loading control signal (Forward) |
| 187 | RGBSEL | Output PD | RGB/YCbCr: select output signal (H: RGB Disable, L: RGB) |
| 188 | XDACS | Output PD | Chip select for DAC (Active Low) |
| 189 | DACVDDC | Power | 3.3V power for Video DAC circuitry |
| 190 | VREF | Analog Input | Bandgap Ref Voltage (No connect) |
| 191 | FS | Analog Input | Full Scale Adjustment |
| 192 | CIN | Output | Compensation capacitor |
| 193 | DACVSSC | Ground | Ground pin for Video DAC circuitry |
| 194 | Y | Output | Analog Y output |
| 195 | DACVddb | Power | 3.3V power for Video DAC circuitry |
| 196 | C | Output | Analog chroma output |
| 197 | DACVSSB | Ground | Ground pin for Video DAC circuitry |
| 198 | CVBS | Output | Analog composit output |
| 199 | DACVDDA | Power | 3.3V power for Video DAC circuitry |
| 200 | Y/G | Output | Green signal on Y signal output |
| 201 | DACVSSA | Ground | Ground pin for Video DAC circuitry |
| 202 | B/Cb/Pb | Output | Blue signal or Cb signal output |
| 203 | R/Cr/Pr | Output | Red signal or Cr signal output |

| Pin No. | Pin name | Type | Function |
|---------|-----------|------------------------------|--|
| 204 | DVDD3 | Power | 3.3V power pin for Video DAC digital circuitry |
| 205 | VSYN | Output SMT | Vertical sync signal output for ITU-R BT.601 |
| 206 | xMAMUTE | Output SMT | Main Audio mute signal |
| 207 | HSYN | Output SMT Output Default | Horizontal sync signal output for ITU-R BT.601 |
| 208 | ADACK | Output | ADAC Serial Clock |
| 209 | NC | | Not used |
| 210 | ADSDO | Output | ADAC Serial data output |
| 211 | NC | | Not used |
| 212 | DVDD3 | Power | 3.3V power pin for internal digital circuitry |
| 213 | ALRCK | Output PD,SMT | Audio left/right channel clock |
| 214 | ABCK | Output | Audio Bit Clock output (ADAC BCK output) |
| 215 | ACLK | Output | Master clock output for Audio DAC (ADAC CLK (Master clock) output) |
| 216 | DVSS | Ground | Ground pin for internal digital circuitry |
| 217 | ASDATA0 | Output PD, SMT | Audio serial data 0:L/R |
| 218 | ASDATA1 | Output PD, SMT | Audio serial data 1:SL/SR |
| 219 | ASDATA2 | Output PD, SMT | Audio serial data 2:C/SW |
| 220 | xRST | Default Low | Reset output signal for ADAC (Low Active) |
| 221 | DVDD18 | Power | 1.8V power pin for internal digital circuitry |
| 222 | ASDATA4 | Output PD,SMT | Audio serial data 4:Down-mixed L/R |
| 223 | DVSS | Ground | Ground pin for internal digital circuitry |
| 224 | DISC/XEXT | Output | DISC/External input select output signal (H: DISC, L: EXT in) |
| 225 | SPDIF | Output | SPDIF output |
| 226 | RFGND18 | Ground | Ground pin for internal analog circuitry |
| 227 | RFVDD18 | Power | 1.8V power pin for internal analog circuitry |
| 228 | XTALO | Output | 27MHz crystal output |
| 229 | XTALI | Input | 27MHz crystal input |
| 230 | JITFO | Analog Output | The output terminal of RF jitter meter |
| 231 | JITFN | Analog Input | The input terminal of RF jitter meter |
| 232 | PLLVSS | Ground | Ground pin for data PLL and related analog circuitry |
| 233 | IDACEXP | Analog Output | Data PLL DAC Low-pass filter |
| 234 | PLLVD3 | Power | 3.3V power pin for data PLL and related analog circuitry |
| 235 | LPFON | Analog Output | The negative output terminal of loop filter amplifier |
| 236 | LPFIP | Analog Input | The positive input terminal of loop filter amplifier |
| 237 | LPFIN | Analog Input | The negative input of loop filter amplifier |
| 238 | LPFOP | Analog Output | The positive output of loop filter amplifier |
| 239 | ADCVD3 | Power | Power pin for ADC circuitry |
| 240 | S_VCM | Analog Input | SACD Common mode reference |
| 241 | ADCVSS | Ground | Ground pin for ADC circuitry |
| 242 | S_VREFP | Analog Input | SACD Top reference |
| 243 | S_VREFN | Analog Input | SACD Bottom reference |
| 244 | RFVDD3 | Power | 3.3V power pin for RF digital circuitry |
| 245 | RFRPDC | Analog Output | RF ripple detect output |
| 246 | RFRPAC | Analog Input | RF ripple detect input (through AC-coupling) |
| 247 | HRFZC | Analog Input | High frequency RF ripple zero crossing |
| 248 | CRTPLP | Analog Output | Defect level filter capacitor connecting |
| 249 | RFGND | Ground | Ground pin for RF digital circuitry |
| 250 | CEQP | Analog Output | EQ offset loop capacitance |
| 251 | CEQN | Analog Input | EQ offset loop capacitance |
| 252 | OSP | Analog Output | RF Offset cancellation capacitor connecting |
| 253 | OSN | Analog Output | RF Offset cancellation capacitor connecting |
| 254 | RFGC | Analog Output | RF AGC loop capacitor connecting for DVD-ROM |
| 255 | IREF | Analog Input | Input reference current input |
| 256 | AVDD3 | Power | 3.3V power pin for analog circuitry |

SECTION 6 TEST MODE

6-1. EXECUTING IOP MEASUREMENT

In order to execute IOP measurement, the following standard procedures must be followed.

- (1) In standby mode, press **[TOP MENU]**, **[CLEAR]**, **[POWER]** to enter Remocon Diagnosis Mode.

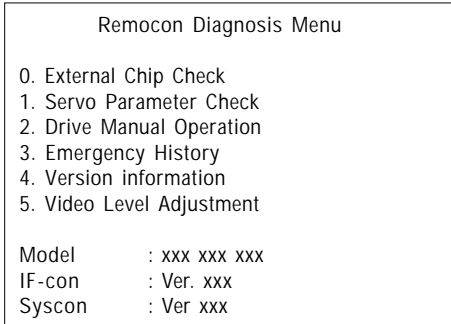

- (2) Select "2. Drive Manual Operation" by pressing the **[2]** key on the remote commander. The screen will appear as below.

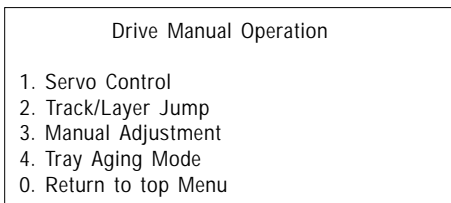

- (3) Select "3. Manual Adjustment" by pressing the **[3]** key on the remote commander. The screen will appear as below.

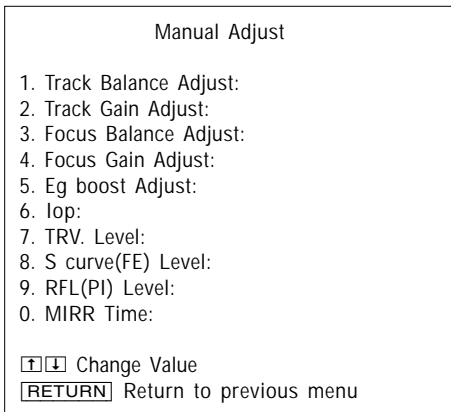

- (4) Select Iop by pressing **[6]** key on the remote commander.

- (5) Wait until a hexadecimal number appear.

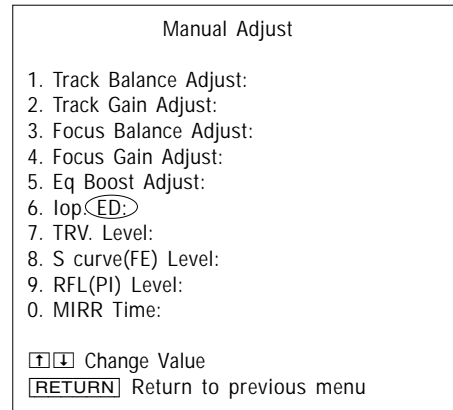

- (6) Convert data from hexadecimal to decimal.

- (7) Use the following formula to calculate IOP in mA
IOP (mA)=IOP (decimal) x 0.622678.

- (8) Press **[RETURN]** to return back to previous menu.

- (9) Press **[0]** to return to Top Menu and power OFF the DVD Player.

6-2. EMERGENCY HISTORY CHECK

Information of Emergency History.

- (1) In standby mode, press **[TOP MENU]**, **[CLEAR]**, **[POWER]** to enter Remocon Diagnosis Mode.

- (2) Select "3. Emergency History".

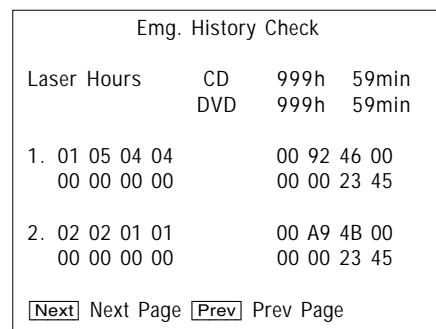

- (3) Laser Hours
DVD Laser ON time. (Total ON time)
CD Laser ON time. (Total ON time)

- (4) Emergency History
The history information from last "1" to "10" can be scrolled with **[NEXT]** key or **[PREV]** key.

- (5) Error code

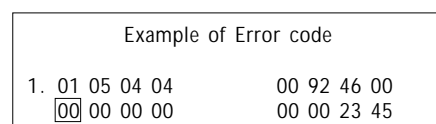

- (6) Error code list
 - 01: Communication error (No reply from syscon)
 - 02: Syscon hung up
 - 03: Power OFF request when syscon hung up
 - 19: Thermal shutdown
 - 24: MoveSledHome error
 - 25: Mecha move error (5 Changer)
 - 26: Mecha move stack error
 - 30: DC Motor adjustment error
 - 31: DPD offset adjustment error
 - 32: TE Balance adjustment error
 - 33: TE Sensor adjustment error
 - 34: TE loop gain adjustment error
 - 35: FE loop gain adjustment error
 - 36: Bad jitter after adjustment
 - 40: Focus NG
 - 42: Focus Layer Jump NG
 - 52: Open kick spindle error
 - 51: Spindle stop error
 - 60: Focus on error
 - 61: Seek fail error
 - 62: read Qdata/ID error
 - 70: Lead In Data Read Fail
 - 71: TOC read time out (CD)
 - 80: Can't Buffering
 - 81: Unknown media type

(7) Error code parameters

| Example of Error code | | | |
|-----------------------|----|-------------|-------------|
| 1. | 01 | 05 04 04 | 00 92 46 00 |
| | | 00 00 00 00 | 00 00 23 45 |

This is the detailed contents of error information

(8) Laser hours at error happend.

| Example of Error code | | | |
|-----------------------|----|-------------|-------------|
| 1. | 01 | 05 04 04 | 00 92 46 00 |
| | | 00 00 00 00 | 00 00 23 45 |

This is Laser hours when an error happend.

(9) How to Clear laser hours

Press **[DISPLAY]**, **[CLEAR]** keys in this order.
Both CD and DVD data are cleared.

| Emg. History Check | | | |
|--------------------|-------------|-------------|------|
| Laser Hours | CD | 0h | 0min |
| | DVD | 0h | 0min |
| 1. | 01 05 04 04 | 00 92 46 00 | |
| | 00 00 00 00 | 00 00 23 45 | |
| 2. | 02 02 01 01 | 00 A9 4B 00 | |
| | 00 00 00 00 | 00 00 23 45 | |

Next Next Page
 Prev Prev Page
0 Return to Top Menu

(10) How to Clearing Emergency code

Press **[TOPMENU]**, **[CLEAR]** keys in this order.
All emergency code are cleared.

| Emg. History Check | | | |
|--------------------|-------------|-------------|-------|
| Laser Hours | CD | 999h | 59min |
| | DVD | 999h | 59min |
| 1. | 00 00 00 00 | 00 00 00 00 | |
| | 00 00 00 00 | 00 00 00 00 | |
| 2. | 00 00 00 00 | 00 00 00 00 | |
| | 00 00 00 00 | 00 00 00 00 | |

Next Next Page
 Prev Prev Page

(11) Press - key, return to TOP MENU.

6-3. INITIALIZING SETUP DATA

How to initializing setup data.

- (1) In standby mode, press **[TOP MENU]**, **[CLEAR]**, **[POWER]** to enter Remocon Diagnosis Mode.
- (2) Select "3. Emergency History".

| Emg. History Check | | | |
|--------------------|-------------|-------------|-------|
| Laser Hours | CD | 999h | 59min |
| | DVD | 999h | 59min |
| 1. | 01 05 04 04 | 00 92 46 00 | |
| | 00 00 00 00 | 00 00 23 45 | |
| 2. | 02 02 01 01 | 00 A9 4B 00 | |
| | 00 00 00 00 | 00 00 23 45 | |

Next Next Page
 Prev Prev Page

(3) Initializing setup data

Press **[MENU]**, **[CLEAR]** keys in this order.
The data have been initialized when "Initialize setup data..." message is displayed.

| Emg. History Check | | | |
|---------------------------|-----|------|-------|
| Laser Hours | CD | 999h | 59min |
| | DVD | 999h | 59min |
| Initialize setup data ... | | | |

Next Next Page
 Prev Prev Page

- (4) The Emergency history display screen will be restored soon.

| Emg. History Check | | | |
|---|-----|-------------|-------|
| Laser Hours | CD | 999h | 59min |
| | DVD | 999h | 59min |
| 1. 01 05 04 04 | | 00 92 46 00 | |
| 00 00 00 00 | | 00 00 23 45 | |
| 2. 02 02 01 01 | | 00 A9 4B 00 | |
| 00 00 00 00 | | 00 00 23 45 | |
| <input type="button" value="Next"/> Next Page <input type="button" value="Prev"/> Prev Page | | | |

- (12) Press key, return to TOP MENU.

6-4. VERSION INFORMATION

Information of firmware version.

- (1) In standby mode, press , , to enter Remocon Diagnosis Mode.
- (2) Select "4. Version Information".

| Version information | |
|---|--------------|
| Firm (Main) | : Ver. xxxxx |
| Firm (Sub) | : xxxxx |
| RISC | : xxxxx |
| 8032 | : xxxxx |
| Audio DSP | : xxxxx |
| Servo DSP | : Ver. xxxxx |
| Sub CPU | : Ver. xxxxx |
| <input type="button" value="0"/> Return to Top Menu | |

- (3) Press key, return to TOP MENU.

6-5. IF CON SELF DIAGNOSTIC FUNCTION

1. IF-146 BOARDS (IF CON)TEXT MODE

The IF-146 boards (IF CON) test mode is the IF CON self-diagnosis mode. The IF CON can diagnose the functions of the IF-146 boards that the IF CON controls. Normally, the IF CON makes a serial communication with the SYSTEM CONTROL and operates following the commands from the SYSTEM CONTROL, but in the Test mode, the IF CON operates independently from the SYSTEM CONTROL.

In the test mode, the following functions can be checked.

1. Button function
2. Remote commander receiving function
3. SYSTEM CONTROL-IF CON serial communication
4. Fluorescent display tube lighting check
 - Grid check
 - Anode check
5. LED control function

In the test mode, the main unit operates same as usual, except voltage monitoring, communication, display of fluorescent display tube, and LED control.

1. The routine that monitors +3.3V (PCONT) of MV-49 boards is not provided.
2. The monitoring timer for serial communication with the SYSTEM CONTROL is not provided. The main unit is not placed in the Standby mode, even if the communication with SYSTEM CONTROL is normal.
3. Display of fluorescent display tube.
(Normally, display is mode following the commands from SYSTEM CONTROL).
4. LED control.
(Normally, control is mode made following the commands from SYSTEM CONTROL).

2. OPERATION OF SELF CHECK MODE

The Self Check mode is the function to conduct the basic test to the FL display and DVD panel section.

2-1. Self Check Mode Transition Processing

At the AC Power ON after reset of IF CON is released, while pressing with the MV-49 boards are not connected to the IF-146 boards, or while pressing the key on the main unit with the IF CON in STANDBY mode, enter → (or) on the remote commander, and the main unit transits to the Self Check Mode.

2-2. Operation of Auto Self Check

When the Self Check mode becomes active at the AC Power ON or by key input, the test display of the following steps (1) to (4) is repeated.

- (1) FLD and LED all ON (for 5 seconds)

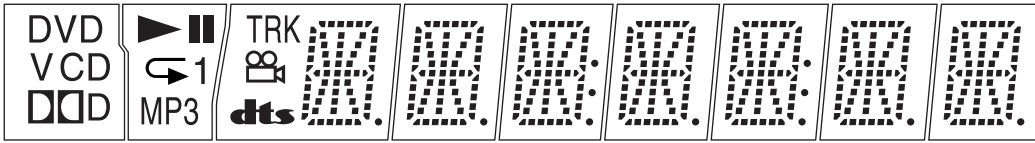

- (2) MODEL display (for 2 seconds)

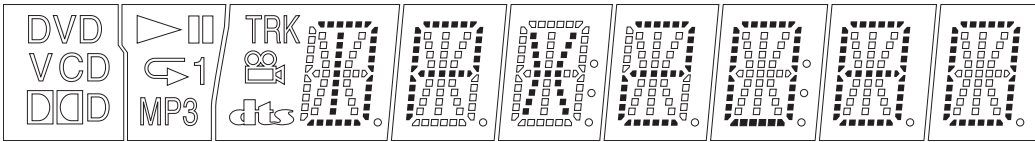

- (3) Version display (for 2 seconds)

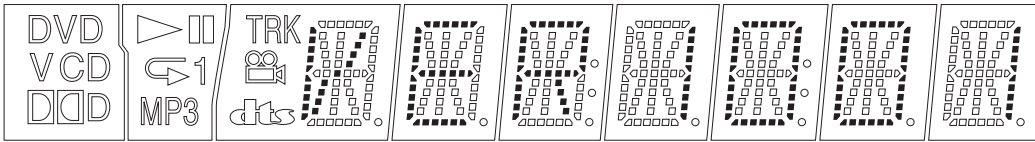

- (4) ROM creation date display (for 2 seconds)

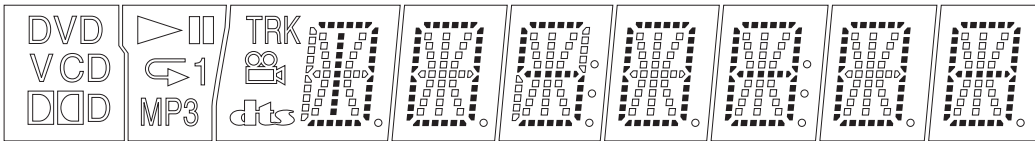



2-3. Each Self Check Function

Each Self Check function tests the FLD display, LED display, and key input.

| Input Voltage [V] | IC404: Pin No. (Signal) | | | |
|----------------------|-------------------------|--------------|---------------|--------|
| | PIN ③④ (AD1) | PIN ③⑤ (O/C) | PIN ③⑥ (STOP) | PIN ③⑦ |
| 0 - 0.20 | PLAY | OPEN/CLOSE | STOP | POWER |
| 0.60 - 0.82 | - | - | PROGRESSIVE | - |
| 1.16 - 1.47 | PREVIOUS | - | - | - |
| 1.80 - 2.12 | NEXT | - | - | - |
| 2.48 - 2.70 | - | - | - | - |

2-3-1. FLD and LED All ON

2-3-1-1. Transition Keys in Self Check Mode

-  key and  key on the main unit
-  key on the remote commander

2-3-1-2. Operation and display

In this mode, all LEDs and all segments of FLD turn ON.

- Example of FLD all ON

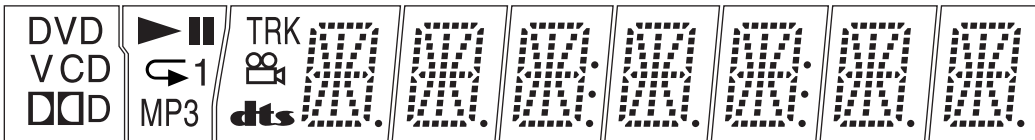

2-3-2. Main Unit Key Name Display and Key Code Display

2-3-2-1. Transition Keys in Self Check Mode

- Keys on the main unit except keys transited in Self Check Mode

2-3-2-2. Operation and Display

When a key on the main unit is pressed in the Self Check mode, the name of that key code is displayed on the FLD. Also, code "NOTHING" is displayed when nothing is entered. Also, DVD, VCD segments turn on when a communication error occurred.

- Key code display
(at input of  key, key code: 0Ah)

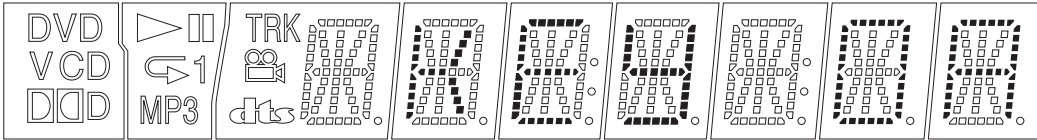

- At input of faulty voltage

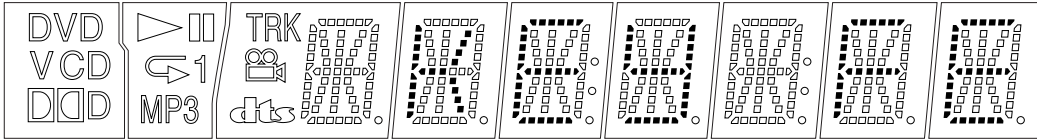

- When key is pressed double

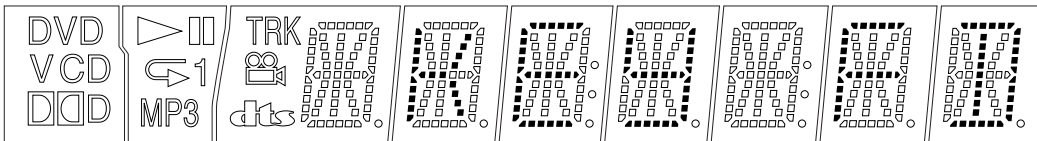

2-3-3. Remote Commander

2-3-3-1. Transition Keys in Self Check Mode

- Remote commander keys except keys transited in Self Check Mode

2-3-3-2. Operation and Display

When a key on the remote commander is pressed in the Self Check Mode, the name of that key code is displayed on the FLD. Also, code "NOTHING" is displayed when nothing is entered. Also, VIDEO CD, DVD, and CD segments turn on when a communication error occurred.

- Remote commander key code display (at input of  key, key code:39h)

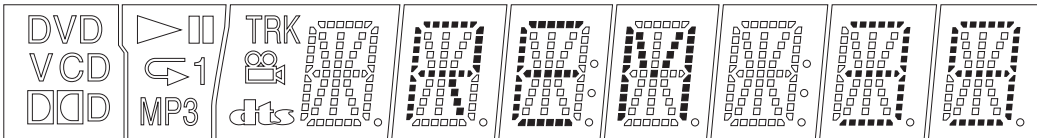

2-3-4. Communication Monitoring Display

The communication state is monitored and displayed while the key name on the main unit and the remote commander is displayed. When the communication to the System Controller failed, VIDEO CD, DVD, and CD segments turn on.

- Communication error display (at no input of key and remote commander)

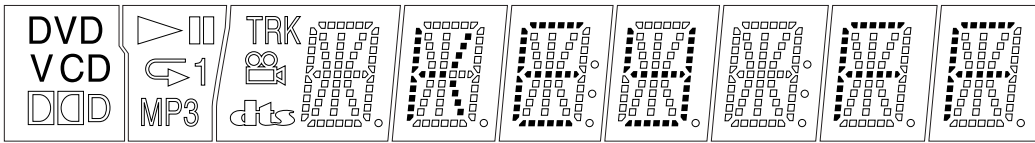

- Communication error display (at code display without input of the remote commander)

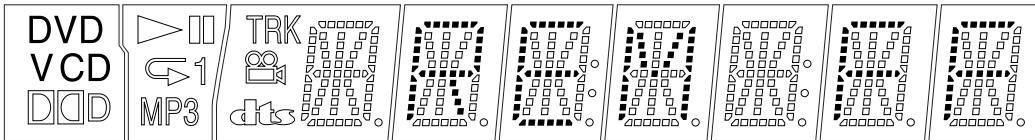

2-3-5. FLD Anode Test Display and SHUTTLE Click Operation Test

2-3-5-1. Transition Keys in Self Check Mode

- [Right Arrow] key on the remote commander
- SHUTTLE on the remote commander during Anode Test display (This unit does not provide JOG/SHUTTLE, and therefore use another DVD remote commander having the JOG/SHUTTLE)

2-3-5-2. Operation and Display

The Self Check Mode transits to this mode when [Right Arrow] key is entered. This tests whether each segment turns on individually. Only the first segment of each grid of FLD turns on, and each time the SHUTTLE is entered, the segment of each grid switched in order. When SHUTTLE input is clockwise, the segment switches in 1 - 2 - 3 direction, or counterclockwise it switches in 3 - 2 - 1 direction.

- Display at the start of Anode Test

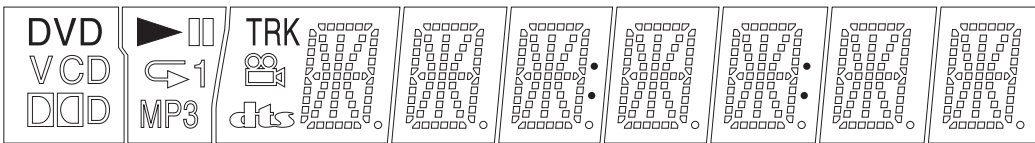

↓ (Input in CW direction)

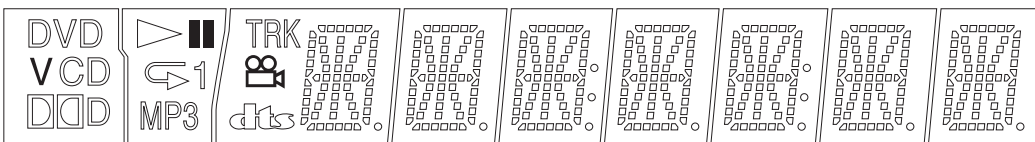

2-3-6. FLD Grid Test Display and SHUTTLE Click Operation Test

2-3-6-1. Transition Keys in Self Check Mode

-  key on the remote commander
- SHUTTLE on the remote commander during Grid Test display
(This unit does not provide JOG/SHUTTLE, and therefore use another DVD remote commander having the JOG/SHUTTLE)

2-3-6-2. Operation and Display

The Self Check Mode transits to this mode when  key is entered. This tests whether each grid turns on individually. The first grid only of FLD turns on and other grid turn off. Each time the SHUTTLE is entered, the grid is switched in order. When SHUTTLE input is clockwise, the grid switched in 1 - 2 - 3 direction, or counterclockwise it switches in 3 - 2 - 1 direction.

- Display at the start of Grid Test

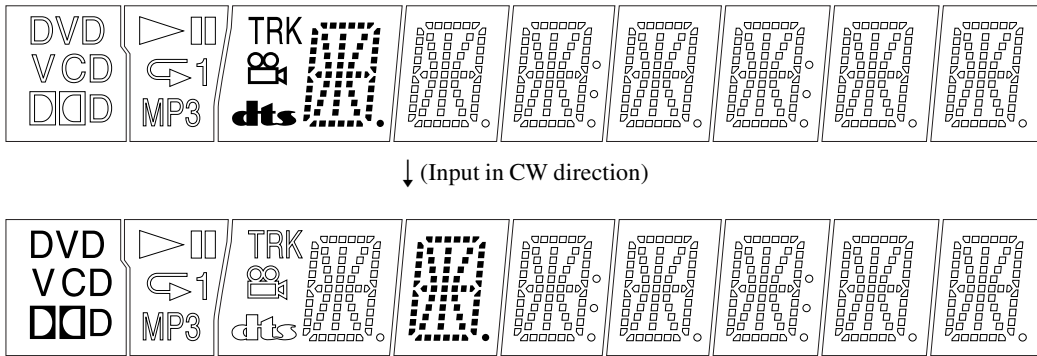

2-3-7. LED Test Display

2-3-7-1. Transition Keys in Self Check Mode

-  key on the remote commander
- SHUTTLE on the remote commander during Grid Test display
(This model does not provide JOG/SHUTTLE, and therefore use another DVD remote commander having the JOG/SHUTTLE)

2-3-7-2. Operation and Display

LED is switched in order by the input JOG/SHUTTLE on the remote commander. Also, LED ON/OFF is switched by the input of same key as the function that turns on the LED concerned.

- FLD display during LED Test

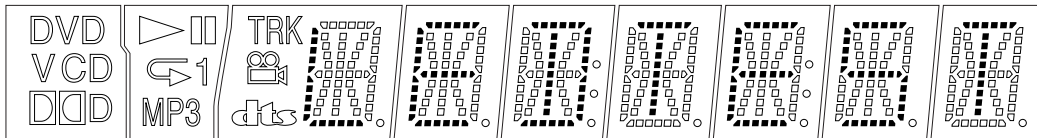

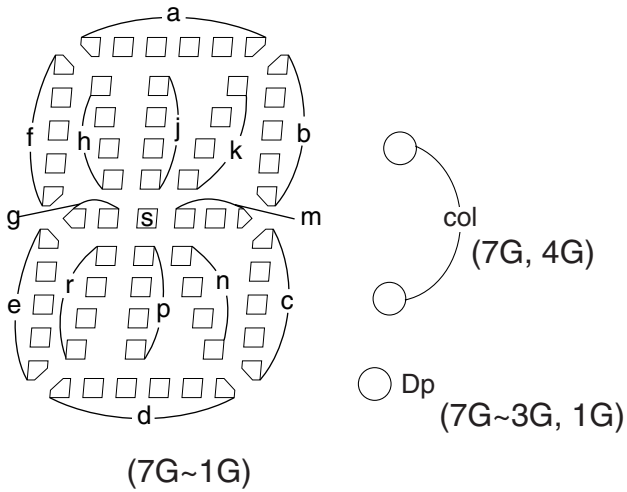
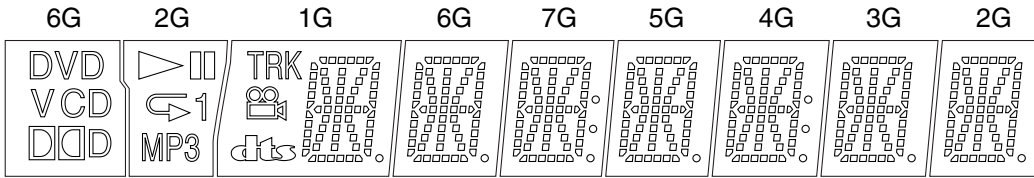

ANODE CONNECTION

| | 7G | 6G | 5G | 4G | 3G | 2G | 1G |
|-----|-----|-----|----|-----|----|-----|-----|
| P1 | col | DVD | - | col | - | ▶ | TRK |
| P2 | - | V | - | - | - | ⏸ | 📹 |
| P3 | - | CD | - | - | - | ↶ | dts |
| P4 | - | DDD | - | - | - | 1 | - |
| P5 | Dp | Dp | Dp | Dp | Dp | MP3 | Dp |
| P6 | a | a | a | a | a | a | a |
| P7 | k | k | k | k | k | k | k |
| P8 | j | j | j | j | j | j | j |
| P9 | h | h | h | h | h | h | h |
| P10 | b | b | b | b | b | b | b |
| P11 | f | f | f | f | f | f | f |
| P12 | m | m | m | m | m | m | m |
| P13 | s | s | s | s | s | s | s |
| P14 | g | g | g | g | g | g | g |
| P15 | c | c | c | c | c | c | c |
| P16 | d | d | d | d | d | d | d |
| P17 | r | r | r | r | r | r | r |
| P18 | p | p | p | p | p | p | p |
| P19 | n | n | n | n | n | n | n |
| P20 | e | e | e | e | e | e | e |

SECTION 7 ELECTRICAL ADJUSTMENT

This section describes procedures and instructions necessary for adjusting electrical circuits in this unit.

Instruments required:

- (1) Color monitor TV
- (2) Oscilloscope 1 or 2 phenomena, band width over 100 MHz, with delay mode
- (3) Frequency counter (over 8 digits)
- (4) Digital multimeter
- (5) Standard commander (RMT-D175A/RMT-D175P)
- (6) DVD reference disc
 HLX-501 (J-6090-071-A) (dual layer) (NTSC)
 HLX-503 (J-6090-069-A) (single layer) (NTSC)
 HLX-504 (J-6090-088-A) (single layer) (NTSC)
 HLX-505 (J-6090-089-A) (dual layer) (NTSC)

7-1. POWER SUPPLY OUTPUT VOLTAGE CHECK

| | |
|------------------|---------------------------|
| Mode | Except standby |
| Instrument | Digital multimeter |
| EVER +5 V Check | |
| Test point | CN201 pin ④ |
| Specification | 5.0 ± 0.3 Vdc |
| SW +3.3 V Check | |
| Test point | CN201 pin ⑤ |
| Specification | 3.35 ± 0.2 Vdc |
| SW+5 V Check | |
| Test point | CN201 pin ⑥ |
| Specification | $5.0^{+0.2}_{-0.3}$ Vdc |
| SW +8 V Check | |
| Test point | CN201 pin ① |
| Specification | 8.0 ± 0.5 Vdc |
| EVER +11 V Check | |
| Test point | CN201 pin ③ |
| Specification | $11.0^{+1.0}_{-0.5}$ Vdc |
| EVER -10 V Check | |
| Test point | CN201 pin ⑩ |
| Specification | $-10.0^{+0.5}_{-1.0}$ Vdc |

Checking method:

- (1) Confirm that each voltage satisfies the specification.

Caution!

Please do not touch any electrical parts at primary circuit to avoid electrical shock.

7-2. ADJUSTMENT OF VIDEO SYSTEM

1. Checking Video Level

<Purpose>

Checking Video Level the NTSC/PAL standard, and if not correct, the brightness will be too large or small.

| | |
|---------------|---|
| Mode | HLX-504 play back |
| Signal | Color bars 100% |
| Test point | LINE OUT (VIDEO) connector (75 Ω terminated) |
| Instrument | Oscilloscope |
| Specification | 1.0 ± 0.08 Vp-p |

Adjusting method:

- 1) In the Video Signal menu "1" Color Bar 100% play back.
- 2) Confirm that the Video Level is 1.0 ± 0.08 Vp-p.

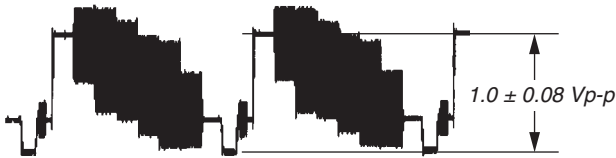

Fig. 7-1.

2. Checking Progressive Video Output Level

<Purpose>

Check progressive video output level. If it is incorrect, correct brightness will not be attained when connected to, for instance, projector.

| | |
|---------------|--|
| Mode | HLX-504 play back |
| Signal | Color bars 100% |
| Test point | COMPONENT VIDEO OUT (Y) connector (75 Ω terminated) |
| Instrument | Oscilloscope |
| Specification | 1.0 ± 0.08 Vp-p |

Adjusting method:

- 1) In the Video Signal menu "1" Color Bar 100% play back.
- 2) Confirm that the Y level is 1.0 ± 0.08 Vp-p.



Fig. 7-2.

3. Checking S Video Output S-Y

<Purpose>

Check S-terminal video output. If it is incorrect, pictures will not be displayed correctly in spite of connection to the TV with a S-terminal cable.

| | |
|---------------|--|
| Mode | HLX-504 play back |
| Signal | Color bars 100% |
| Test point | S VIDEO OUT (S-Y) connector (75 Ω terminated) |
| Instrument | Oscilloscope |
| Specification | 1.0 ± 0.08 Vp-p |

Checking method:

- 1) In the Video Signal menu "1" Color Bar 100% play back.
- 2) Confirm that the S-Y level is 1.0 ± 0.08 Vp-p.

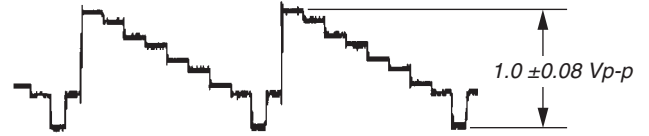

Fig. 7-3.

4. Checking S Video Output S-C

<Purpose>

This checks whether the S-C satisfies the NTSC/PAL standard. If it is not correct, the colors will be too dark or light.

| | |
|---------------|---|
| Mode | HLX-504 play back |
| Signal | Color bars 100% |
| Test point | S VIDEO OUT (S-C) connector (75 Ω terminated) |
| Instrument | Oscilloscope |
| Specification | A = 286 ± 50 mVp-p (NTSC) A = 300 ± 50 mVp-p (PAL) |

Checking method:

- 1) In the Video Signal menu "1" Color Bar 100% play back.
- 2) Confirm that the S-C burst is "A".

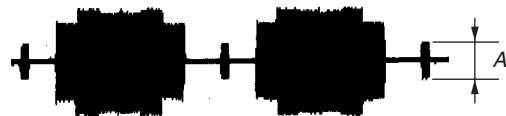

Fig. 7-4.

5. Checking Component Video Output Y

<Purpose>

This checks component video output Y. If it is incorrect, correct brightness will not be attained when connected to, for instance, projector.

| | |
|---------------|--|
| Mode | HLX-504 play back |
| Signal | Color bars |
| Test point | COMPONENT VIDEO OUT (Y) connector, (75 Ω terminated) |
| Instrument | Oscilloscope |
| Specification | $1.0 \pm 0.08 \text{ Vp-p}$ |

Checking method:

- 1) In the Video Signal menu "1" Color Bar 100% play back.
- 2) Confirm that the Y level is $1.0 \pm 0.08 \text{ Vp-p}$.



Fig. 7-5.

6. Checking Component Video Output B-Y

<Purpose>

This checks component video output B-Y. If it is incorrect, correct colors will not be displayed when connected to, for instance, projector.

| | |
|---------------|---|
| Mode | HLX-504 play back |
| Signal | Color bars |
| Test point | COMPONENT VIDEO OUT (P _B) connector (75 Ω terminated) |
| Instrument | Oscilloscope |
| Specification | $A = 700 \pm 70 \text{ mVp-p}$ |

Checking method:

- 1) In the Video Signal menu "1" Color Bar 100% play back.
- 2) Confirm that the B-Y level is A.

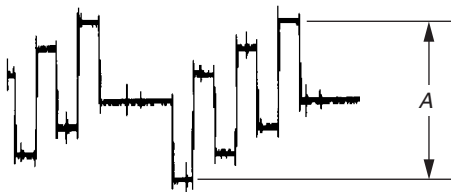

Fig. 7-6.

7. Checking Component Video Output R-Y

<Purpose>

This checks component video output R-Y. If it is incorrect, correct colors will not be displayed when connected to, for instance, projector.

| | |
|---------------|---|
| Mode | HLX-504 play back |
| Signal | Color bars |
| Test point | COMPONENT VIDEO OUT (P _R) connector (75 Ω terminated) |
| Instrument | Oscilloscope |
| Specification | $B = 700 \pm 70 \text{ mVp-p}$ |

Checking method:

- 1) In the Video Signal menu "1" Color Bar 100% play back.
- 2) Confirm that the R-Y level is B.

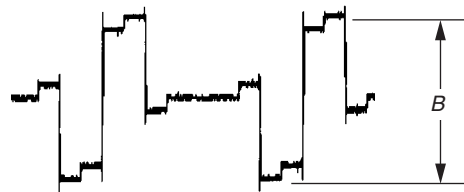

Fig. 7-7.

SECTION 8 REPAIR PARTS LIST

8-1. EXPLODED VIEWS

NOTE:

- -XX and -X mean standardized parts, so they may have some difference from the original one.
- Items marked "*" are not stocked since they are seldom required for routine service. Some delay should be anticipated when ordering these items.
- The mechanical parts with no reference number in the exploded views are not supplied.
- Color Indication of Appearance Parts
Example:
KNOB, BALANCE (WHITE) . . . (RED)

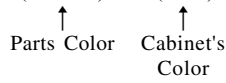

- Abbreviation
AEP : Europe Model
CND : Canadian Model
E : Latin America Model
KR : Korea Model
RUS : Russian Model
SP : Singapore Model

The components identified by mark \triangle or dotted line with mark \triangle are critical for safety. Replace only with part number specified.

8-1-1. MAIN SECTION

ns : not supplied

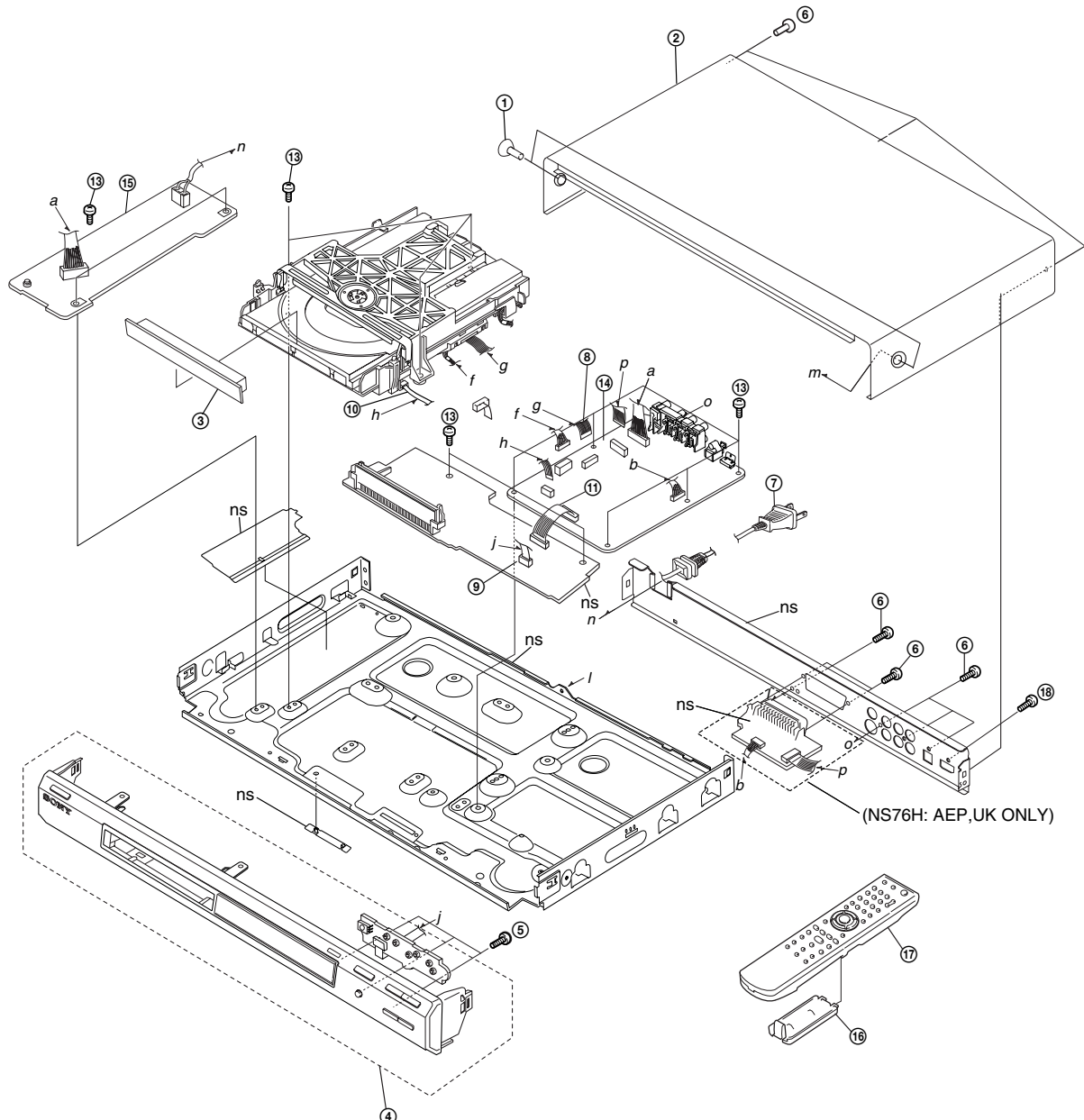

DVP-NS71HP/NS75H/NS76H

| <u>Ref. No.</u> | <u>Part No.</u> | <u>Description</u> | <u>Remark</u> |
|-----------------|-----------------|---|---------------|
| 1 | 3-070-883-41 | SCREW, TAPPING | |
| 2 | A-1164-622-A | SERVICE ASSY, CASE UPPER | |
| 3 | 2-660-717-11 | COVER, TRAY (NS71HP/NS75H) | |
| 3 | 2-660-717-41 | COVER, TRAY (NS76H) | |
| 4 | X-2108-001-1 | PANEL ASSY, FRONT (NS71HP/NS75H) | |
| 4 | X-2108-006-2 | PANEL ASSY, FRONT (NS76H) | |
| 4 | X-2148-042-1 | PANEL ASSY, FRONT (NS71HP) | |
| 5 | 3-087-053-01 | +BVTP2.6 (3CR) | |
| 6 | 3-077-331-11 | +BV3 (3-CR) | |
| △7 | 1-828-451-11 | POWER-SUPPLY CORD (NS71HP/NS75H) | |
| △7 | 1-828-450-11 | POWER-SUPPLY CORD (EXCEPT NS76H:UK,KR) | |
| △7 | 1-828-454-11 | POWER-SUPPLY CORD (NS76H:UK) | |
| △7 | 1-828-871-11 | POWER-SUPPLY CORD (NS76H:KR) | |
| 8 | 1-831-570-11 | CABLE, FLEXIBLE FLAT (FMO-010) | |
| 9 | 1-831-569-11 | CABLE, FLEXIBLE FLAT (FSW-002) | |
| * 10 | 1-831-571-11 | CABLE, FLEXIBLE FLAT (FMS-011) | |
| * 11 | 1-831-572-11 | CABLE, FLEXIBLE FLAT (FIM-014) | |
| * 12 | 1-831-575-11 | CABLE, FLEXIBLE FLAT (FME-005) (NS76H:AEP,UK,RUS) | |
| 13 | 3-077-331-21 | +BV3 (3-CR) | |
| 14 | A-1164-623-A | SERVICE ASSY, MV (NS71HP/NS75H) | |
| 14 | A-1164-642-A | SERVICE ASSY, MV (NS76H:E) | |
| 14 | A-1164-630-A | SERVICE ASSY, MV (NS76H:SP) | |
| 14 | A-1166-008-A | SERVICE ASSY, MV (NS76H:KR) | |
| 14 | A-1171-331-A | SERVICE ASSY, MV (NS76H:AEP,UK) | |
| 14 | A-1171-483-A | SERVICE ASSY, MV (NS76H:RUS) | |
| △15 | 1-468-974-11 | POWER SUPPLY BLOCK (NS71HP/NS75H) | |
| △15 | 1-468-973-11 | POWER SUPPLY BLOCK (NS76H) | |
| 16 | 3-081-834-21 | BATTERY COVER (SMK7G) | |
| 17 | 1-479-179-11 | REMOTE COMMANDER (RMT-D175A) (NS71HP/NS75H/NS76H:E,KR) | |
| 17 | 1-479-179-21 | REMOTE COMMANDER (RMT-D175P) (NS76H:SP,AEP,UK,RUS) | |
| 18 | 3-088-023-01 | +B3 (3-CR) | |

Note :
The components identified by mark △ or dotted line with mark △ are critical for safety. Replace only with part number specified.

8-1-2. MECHANISM DECK ASSEMBLY

ns : not supplied

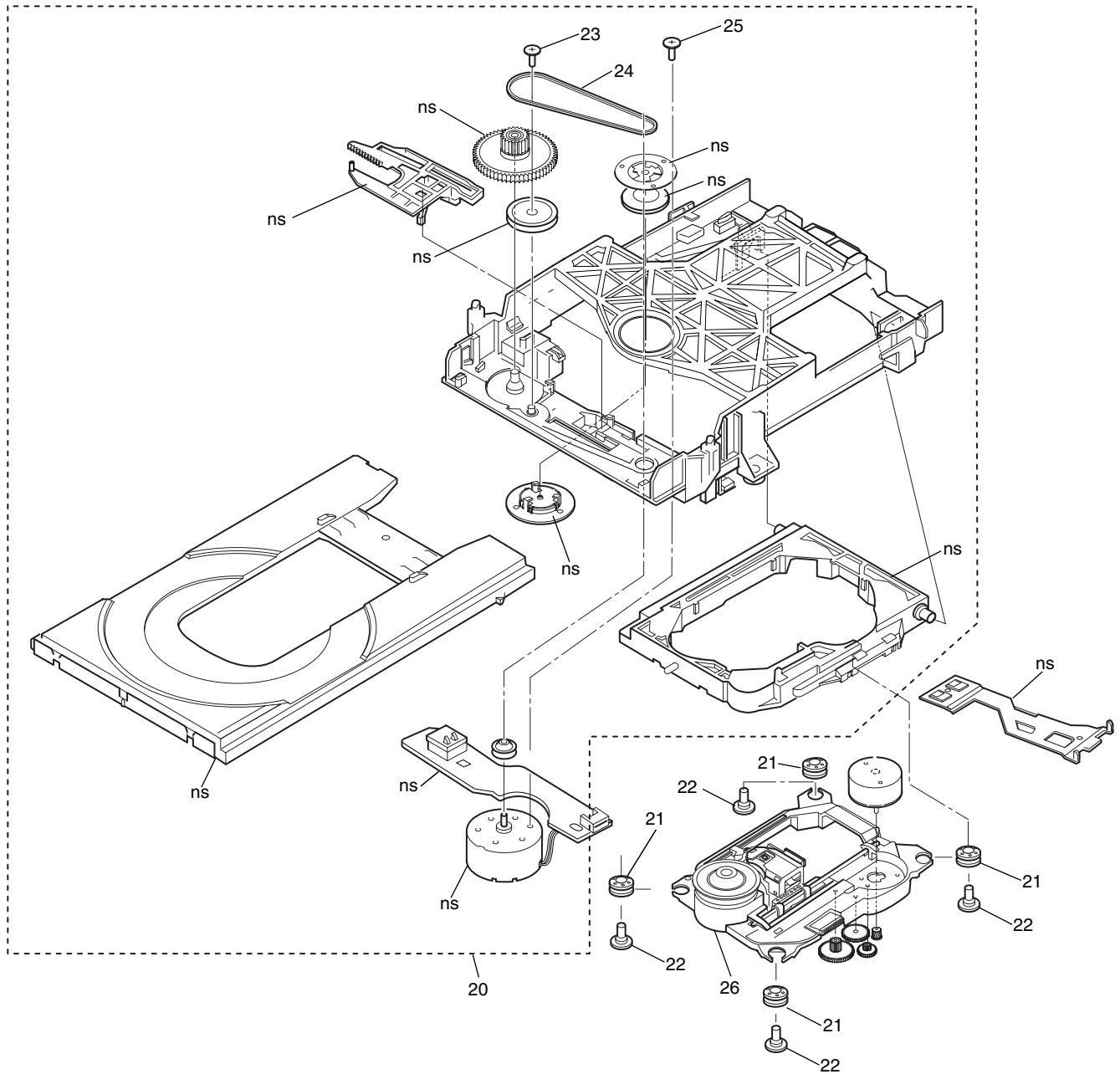

| Ref. No. | Part No. | Description | Remark |
|----------|--------------|--------------------------------|--------|
| 20 | A-6071-669-A | LOADING ASSY(M) | |
| 21 | 3-088-372-01 | INSULATOR | |
| 22 | 3-087-599-01 | INSULATOR SCREW | |
| 23 | 4-674-137-11 | SCREW (PTP2X5) | |
| 24 | 3-088-371-01 | BELT | |
| 25 | 4-974-725-11 | SCREW (M1.7X2.5), P | |
| △ 26 | 8-820-321-05 | DEVICE,OPTICAL KHM-313CAA/C2RP | |

ER-41

8-2. ELECTRICAL PARTS LIST

NOTE:

- Due to standardization, replacements in the parts list may be different from the parts specified in the diagrams or the components used on the set.
- -XX and -X mean standardized parts, so they may have some difference from the original one.
- RESISTORS
All resistors are in ohms.
METAL: Metal-film resistor.
METAL OXIDE: Metal oxide-film resistor.
F: nonflammable
- Not all of the parts for POWER BLOCK (HS12S2U) are listed.
- Items marked "*" are not stocked since they are seldom required for routine service.
Some delay should be anticipated when ordering these items.

- SEMICONDUCTORS
In each case, u: μ , for example:
uA. . : μ A. . uPA. . : μ PA. .
uPB. . : μ PB. . uPC. . : μ PC. .
uPD. . : μ PD. .
- CAPACITORS
uF: μ F
- COILS
uH: μ H
- Abbreviation
AEP : Europe Model
CND : Canadian Model
E : Latin America Model
KR : Korea Model
RUS : Russian Model
SP : Singapore Model

The components identified by mark Δ or dotted line with mark Δ are critical for safety. Replace only with part number specified.

When indicating parts by reference number, please include the board.

| Ref. No. | Part No. | Description | Remark | Ref. No. | Part No. | Description | Remark |
|----------|--------------|----------------------------|-------------------|----------|--------------|------------------------------|--------|
| | | ER-41 BOARD ***** | | | | <FERRITE> | |
| | | <CAPACITOR> | | FB907 | 1-469-796-21 | FERRITE, CHIP | |
| C904 | 1-126-947-11 | CAP, ELECT | 47MF | FB908 | 1-469-796-21 | FERRITE, CHIP | |
| C905 | 1-126-947-11 | CAP, ELECT | 47MF | FB909 | 1-469-796-21 | FERRITE, CHIP | |
| C906 | 1-126-947-11 | CAP, ELECT | 47MF | FB910 | 1-469-796-21 | FERRITE, CHIP | |
| C907 | 1-126-947-11 | CAP, ELECT | 47MF | FB911 | 1-414-233-22 | FERRITE | 0UH |
| C909 | 1-162-970-91 | CERAMIC CHIP | 0.01UF 10.00% 25V | FB957 | 1-414-233-22 | FERRITE | 0UH |
| C910 | 1-162-970-91 | CERAMIC CHIP | 0.01UF 10.00% 25V | FB958 | 1-414-233-22 | FERRITE | 0UH |
| C913 | 1-164-489-91 | CERAMIC CHIP | 0.22UF 10.00% 16V | | | <IC> | |
| C914 | 1-164-489-91 | CERAMIC CHIP | 0.22UF 10.00% 16V | IC901 | 6-705-924-01 | IC LA73052-TLM-E | |
| C943 | 1-162-927-91 | CERAMIC CHIP | 100PF 5.00% 50V | IC902 | 8-759-667-17 | IC L79M05TLL-SONY-TL-E | |
| C945 | 1-162-927-91 | CERAMIC CHIP | 100PF 5.00% 50V | | | <RESISTOR> | |
| C962 | 1-163-251-91 | CERAMIC CHIP | 100PF 5.00% 50V | JR902 | 1-216-295-91 | SHORT CHIP | 0 |
| C963 | 1-163-251-91 | CERAMIC CHIP | 100PF 5.00% 50V | JR905 | 1-216-295-91 | SHORT CHIP | 0 |
| | | <CONNECTOR> | | JR906 | 1-216-295-91 | SHORT CHIP | 0 |
| CN901 | 1-815-387-11 | CONNECTOR, FPC/FPC 21P | | JR907 | 1-216-295-91 | SHORT CHIP | 0 |
| * CN902 | 1-568-942-11 | PIN, CONNECTOR 4P | | JR914 | 1-216-295-91 | SHORT CHIP | 0 |
| CN903 | 1-816-044-12 | CONNECTOR, SQUARE TYPE 21P | | JR918 | 1-216-295-91 | SHORT CHIP | 0 |
| | | <DIODE> | | | | <TRANSISTOR> | |
| D901 | 8-719-988-61 | DIODE 1SS355TE-17 | | Q901 | 8-729-024-89 | TRANSISTOR MUN2213T1 | |
| D902 | 8-719-988-61 | DIODE 1SS355TE-17 | | Q902 | 8-729-024-89 | TRANSISTOR MUN2213T1 | |
| D907 | 8-719-050-37 | DIODE M1MA152WA-T1 | | Q903 | 8-729-024-83 | TRANSISTOR MUN2111T1 | |
| D929 | 8-719-069-56 | DIODE UDZSTE-176.2B | | Q906 | 8-729-024-89 | TRANSISTOR MUN2213T1 | |
| D930 | 8-719-083-63 | DIODE UDZSTE-1713B | | Q907 | 8-729-024-83 | TRANSISTOR MUN2111T1 | |
| D932 | 8-719-071-15 | DIODE HZM6.8ZWA1TL | | Q908 | 8-729-024-87 | TRANSISTOR MUN2211T1 | |
| D933 | 8-719-071-15 | DIODE HZM6.8ZWA1TL | | Q909 | 8-729-024-89 | TRANSISTOR MUN2213T1 | |
| D934 | 8-719-071-15 | DIODE HZM6.8ZWA1TL | | Q910 | 6-550-840-01 | TRANSISTOR 2SC2712-YGR-TE85L | |
| D935 | 8-719-071-15 | DIODE HZM6.8ZWA1TL | | Q911 | 6-550-840-01 | TRANSISTOR 2SC2712-YGR-TE85L | |
| D938 | 8-719-988-61 | DIODE 1SS355TE-17 | | Q912 | 6-550-841-01 | TRANSISTOR 2SA1162-YGR-TE85L | |
| D939 | 8-719-988-61 | DIODE 1SS355TE-17 | | Q913 | 6-550-841-01 | TRANSISTOR 2SA1162-YGR-TE85L | |

DVP-NS71HP/NS75H/NS76H

IF-146

MV

| Ref. No. | Part No. | Description | Remark | | | Ref. No. | Part No. | Description | Remark | | |
|--------------|--------------|---|------------|--------|-------|----------|--------------|--------------|----------|--------|-----|
| R418 | 1-216-073-91 | RES, CHIP | 10K (2012) | | | C119 | 1-124-779-21 | ELECT CHIP | 10UF | 20.00% | 16V |
| R419 | 1-216-073-91 | RES, CHIP | 10K (2012) | | | C120 | 1-165-908-91 | CERAMIC CHIP | 1UF | 10% | 10V |
| R420 | 1-216-027-91 | RES-CHIP | 120 | 5% | 1/10W | C121 | 1-165-908-91 | CERAMIC CHIP | 1UF | 10% | 10V |
| R421 | 1-216-013-91 | RES-CHIP | 33 | 5% | 1/10W | C122 | 1-165-908-91 | CERAMIC CHIP | 1UF | 10% | 10V |
| R422 | 1-216-097-91 | RES-CHIP | 100K | 5% | 1/10W | C123 | 1-165-908-91 | CERAMIC CHIP | 1UF | 10% | 10V |
| R423 | 1-216-065-91 | RES-CHIP | 4.7K | 5% | 1/10W | C124 | 1-165-908-91 | CERAMIC CHIP | 1UF | 10% | 10V |
| R426 | 1-216-073-91 | RES, CHIP | 10K (2012) | | | C125 | 1-107-826-91 | CERAMIC CHIP | 0.1UF | 10.00% | 16V |
| R427 | 1-216-083-91 | RES-CHIP | 27K | 5% | 1/10W | C126 | 1-107-826-91 | CERAMIC CHIP | 0.1UF | 10.00% | 16V |
| R433 | 1-216-073-91 | RES, CHIP (NS76H ONLY) | 10K (2012) | | | C127 | 1-162-970-91 | CERAMIC CHIP | 0.01UF | 10.00% | 25V |
| R434 | 1-216-073-91 | RES, CHIP (NS76H ONLY) | 10K (2012) | | | C128 | 1-162-965-91 | CERAMIC CHIP | 0.0015UF | 10.00% | 50V |
| R436 | 1-216-073-91 | RES, CHIP (NS71HP/NS75H/NS76H:E) | 10K (2012) | | | C130 | 1-107-826-91 | CERAMIC CHIP | 0.1UF | 10.00% | 16V |
| R436 | 1-216-065-91 | RES-CHIP (NS76H: SP, KR) | 4.7K | 5% | 1/10W | C131 | 1-125-889-91 | CERAMIC CHIP | 2.2UF | 10% | 10V |
| R436 | 1-216-057-91 | RES-CHIP (NS76H: AEP,UK) | 2.2K | 5% | 1/10W | C132 | 1-107-826-91 | CERAMIC CHIP | 0.1UF | 10.00% | 16V |
| R436 | 1-216-081-91 | RES-CHIP (NS76H: RUS) | 22K | 5% | 1/10W | C133 | 1-107-826-91 | CERAMIC CHIP | 0.1UF | 10.00% | 16V |
| R437 | 1-216-073-91 | RES, CHIP (NS71HP/NS75H/NS76H:SP,KR) | 10K (2012) | | | C135 | 1-164-677-91 | CERAMIC CHIP | 0.033UF | 10.00% | 16V |
| R437 | 1-216-057-91 | RES-CHIP (NS76H:E) | 2.2K | 5% | 1/10W | C136 | 1-162-970-91 | CERAMIC CHIP | 0.01UF | 10.00% | 25V |
| R437 | 1-216-081-91 | RES-CHIP (NS76H:RUS) | 22K | 5% | 1/10W | C137 | 1-107-826-91 | CERAMIC CHIP | 0.1UF | 10.00% | 16V |
| R439 | 1-216-073-91 | RES, CHIP | 10K (2012) | | | C138 | 1-162-964-91 | CERAMIC CHIP | 0.001UF | 10.00% | 50V |
| R440 | 1-216-295-91 | SHORT CHIP | 0 | | | C139 | 1-162-919-91 | CERAMIC CHIP | 22PF | 5.00% | 50V |
| | | <TRANSFORMER> | | | | C140 | 1-107-826-91 | CERAMIC CHIP | 0.1UF | 10.00% | 16V |
| T401 | 1-443-906-11 | DC-DC CONVERTER TRANSFORMER | | | | C141 | 1-107-826-91 | CERAMIC CHIP | 0.1UF | 10.00% | 16V |
| | | <VIBRATOR> | | | | C142 | 1-107-826-91 | CERAMIC CHIP | 0.1UF | 10.00% | 16V |
| X401 | 1-781-472-21 | VIBRATOR, CERAMIC | | | | C143 | 1-107-826-91 | CERAMIC CHIP | 0.1UF | 10.00% | 16V |
| | | | | | | C144 | 1-162-970-91 | CERAMIC CHIP | 0.01UF | 10.00% | 25V |
| | | | | | | C145 | 1-165-908-91 | CERAMIC CHIP | 1UF | 10% | 10V |
| | | | | | | C147 | 1-165-176-91 | CERAMIC CHIP | 0.047UF | 10.00% | 16V |
| | | | | | | C148 | 1-165-176-91 | CERAMIC CHIP | 0.047UF | 10.00% | 16V |
| | | | | | | C149 | 1-107-826-91 | CERAMIC CHIP | 0.1UF | 10.00% | 16V |
| | | | | | | C150 | 1-124-779-21 | ELECT CHIP | 10UF | 20.00% | 16V |
| | | | | | | C151 | 1-162-964-91 | CERAMIC CHIP | 0.001UF | 10.00% | 50V |
| | | | | | | C152 | 1-162-917-91 | CERAMIC CHIP | 15PF | 5.00% | 50V |
| | | | | | | C153 | 1-162-917-91 | CERAMIC CHIP | 15PF | 5.00% | 50V |
| | | | | | | C154 | 1-107-826-91 | CERAMIC CHIP | 0.1UF | 10.00% | 16V |
| | | | | | | C155 | 1-162-970-91 | CERAMIC CHIP | 0.01UF | 10.00% | 25V |
| | | | | | | C156 | 1-162-970-91 | CERAMIC CHIP | 0.01UF | 10.00% | 25V |
| | | | | | | C157 | 1-162-970-91 | CERAMIC CHIP | 0.01UF | 10.00% | 25V |
| | | | | | | C158 | 1-162-970-91 | CERAMIC CHIP | 0.01UF | 10.00% | 25V |
| | | | | | | C160 | 1-162-970-91 | CERAMIC CHIP | 0.01UF | 10.00% | 25V |
| | | | | | | C161 | 1-162-970-91 | CERAMIC CHIP | 0.01UF | 10.00% | 25V |
| | | | | | | C162 | 1-162-970-91 | CERAMIC CHIP | 0.01UF | 10.00% | 25V |
| | | | | | | C163 | 1-162-970-91 | CERAMIC CHIP | 0.01UF | 10.00% | 25V |
| | | | | | | C164 | 1-162-970-91 | CERAMIC CHIP | 0.01UF | 10.00% | 25V |
| | | | | | | C171 | 1-162-970-91 | CERAMIC CHIP | 0.01UF | 10.00% | 25V |
| | | | | | | C172 | 1-162-970-91 | CERAMIC CHIP | 0.01UF | 10.00% | 25V |
| | | | | | | C173 | 1-162-964-91 | CERAMIC CHIP | 0.001UF | 10.00% | 50V |
| | | | | | | C174 | 1-162-970-91 | CERAMIC CHIP | 0.01UF | 10.00% | 25V |
| | | | | | | C175 | 1-162-970-91 | CERAMIC CHIP | 0.01UF | 10.00% | 25V |
| | | | | | | C176 | 1-162-970-91 | CERAMIC CHIP | 0.01UF | 10.00% | 25V |
| | | | | | | C177 | 1-128-994-21 | ELECT CHIP | 47UF | 20% | 10V |
| | | | | | | C179 | 1-107-826-91 | CERAMIC CHIP | 0.1UF | 10.00% | 16V |
| | | | | | | C180 | 1-107-826-91 | CERAMIC CHIP | 0.1UF | 10.00% | 16V |
| | | | | | | C181 | 1-107-826-91 | CERAMIC CHIP | 0.1UF | 10.00% | 16V |
| | | | | | | C182 | 1-127-715-91 | CERAMIC CHIP | 0.22UF | 10% | 16V |
| | | | | | | C183 | 1-128-934-91 | CERAMIC CHIP | 0.33UF | 20% | 10V |
| | | | | | | C184 | 1-162-970-91 | CERAMIC CHIP | 0.01UF | 10.00% | 25V |
| | | | | | | C186 | 1-127-715-91 | CERAMIC CHIP | 0.22UF | 10% | 16V |
| | | | | | | C187 | 1-126-208-21 | ELECT CHIP | 47UF | 20.00% | 4V |
| | | | | | | C189 | 1-107-826-91 | CERAMIC CHIP | 0.1UF | 10.00% | 16V |
| | | | | | | C190 | 1-128-994-21 | ELECT CHIP | 47UF | 20% | 10V |
| | | | | | | C191 | 1-107-826-91 | CERAMIC CHIP | 0.1UF | 10.00% | 16V |
| A-1164-623-A | | SERVICE ASSY, MV NS71HP/NS75H) | | | | | | | | | |
| A-1164-642-A | | SERVICE ASSY, MV (NS76H:E) | | | | | | | | | |
| A-1164-630-A | | SERVICE ASSY, MV (NS76H:SP) | | | | | | | | | |
| A-1166-008-A | | SERVICE ASSY, MV (NS76H:KR) | | | | | | | | | |
| A-1171-331-A | | SERVICE ASSY, MV (NS76H:AEP,UK) | | | | | | | | | |
| A-1171-483-A | | SERVICE ASSY, MV (NS76H:RUS) | | | | | | | | | |
| | | ***** | | | | | | | | | |
| | | <CAPACITOR> | | | | | | | | | |
| C101 | 1-162-970-91 | CERAMIC CHIP | 0.01UF | 10.00% | 25V | | | | | | |
| C102 | 1-127-715-91 | CERAMIC CHIP | 0.22UF | 10% | 16V | | | | | | |
| C103 | 1-162-970-91 | CERAMIC CHIP | 0.01UF | 10.00% | 25V | | | | | | |
| C105 | 1-128-994-21 | ELECT CHIP | 47UF | 20% | 10V | | | | | | |
| C106 | 1-162-970-91 | CERAMIC CHIP | 0.01UF | 10.00% | 25V | | | | | | |
| C112 | 1-128-994-21 | ELECT CHIP | 47UF | 20% | 10V | | | | | | |
| C113 | 1-162-970-91 | CERAMIC CHIP | 0.01UF | 10.00% | 25V | | | | | | |
| C114 | 1-107-826-91 | CERAMIC CHIP | 0.1UF | 10.00% | 16V | | | | | | |
| C115 | 1-107-826-91 | CERAMIC CHIP | 0.1UF | 10.00% | 16V | | | | | | |
| C116 | 1-107-826-91 | CERAMIC CHIP | 0.1UF | 10.00% | 16V | | | | | | |
| C117 | 1-124-779-21 | ELECT CHIP | 10UF | 20.00% | 16V | | | | | | |
| C118 | 1-124-779-21 | ELECT CHIP | 10UF | 20.00% | 16V | | | | | | |

| Ref. No. | Part No. | Description | | | Remark | Ref. No. | Part No. | Description | | | Remark |
|----------|--------------|--------------|----------|--------|--------|----------|--------------|---|----------|--------|--------|
| C192 | 1-162-970-91 | CERAMIC CHIP | 0.01UF | 10.00% | 25V | C508 | 1-162-927-91 | CERAMIC CHIP | 100PF | 5.00% | 50V |
| C193 | 1-127-715-91 | CERAMIC CHIP | 0.22UF | 10% | 16V | | | (NS76H:AEP,UK,RUS ONLY) | | | |
| C195 | 1-127-715-91 | CERAMIC CHIP | 0.22UF | 10% | 16V | C509 | 1-162-927-91 | CERAMIC CHIP | 100PF | 5.00% | 50V |
| | | | | | | | | (NS76H:AEP,UK,RUS ONLY) | | | |
| C197 | 1-107-826-91 | CERAMIC CHIP | 0.1UF | 10.00% | 16V | C510 | 1-162-927-91 | CERAMIC CHIP | 100PF | 5.00% | 50V |
| C198 | 1-165-908-91 | CERAMIC CHIP | 1UF | 10% | 10V | | | (NS76H:AEP,UK,RUS ONLY) | | | |
| C199 | 1-162-968-91 | CERAMIC CHIP | 0.0047UF | 10.00% | 50V | C511 | 1-162-927-91 | CERAMIC CHIP | 100PF | 5.00% | 50V |
| C203 | 1-162-970-91 | CERAMIC CHIP | 0.01UF | 10.00% | 25V | | | (NS76H:AEP,UK,RUS ONLY) | | | |
| C205 | 1-164-230-91 | CERAMIC CHIP | 220PF | 5.00% | 50V | C602 | 1-128-994-21 | ELECT CHIP | 47UF | 20% | 10V |
| C206 | 1-164-230-91 | CERAMIC CHIP | 220PF | 5.00% | 50V | C603 | 1-128-994-21 | ELECT CHIP | 47UF | 20% | 10V |
| C208 | 1-162-970-91 | CERAMIC CHIP | 0.01UF | 10.00% | 25V | C604 | 1-163-251-91 | CERAMIC CHIP | 100PF | 5.00% | 50V |
| C209 | 1-164-677-91 | CERAMIC CHIP | 0.033UF | 10.00% | 16V | | | (NS76H:AEP,UK,RUS ONLY) | | | |
| C210 | 1-162-970-91 | CERAMIC CHIP | 0.01UF | 10.00% | 25V | C610 | 1-127-715-91 | CERAMIC CHIP | 0.22UF | 10% | 16V |
| C211 | 1-164-677-91 | CERAMIC CHIP | 0.033UF | 10.00% | 16V | | | | | | |
| C212 | 1-162-970-91 | CERAMIC CHIP | 0.01UF | 10.00% | 25V | C701 | 1-107-826-91 | CERAMIC CHIP | 0.1UF | 10.00% | 16V |
| C213 | 1-162-970-91 | CERAMIC CHIP | 0.01UF | 10.00% | 25V | C702 | 1-107-826-91 | CERAMIC CHIP | 0.1UF | 10.00% | 16V |
| C214 | 1-162-964-91 | CERAMIC CHIP | 0.001UF | 10.00% | 50V | C703 | 1-162-970-91 | CERAMIC CHIP | 0.01UF | 10.00% | 25V |
| C215 | 1-162-970-91 | CERAMIC CHIP | 0.01UF | 10.00% | 25V | C704 | 1-107-826-91 | CERAMIC CHIP | 0.1UF | 10.00% | 16V |
| C217 | 1-126-204-21 | ELECT CHIP | 47UF | 20.00% | 16V | C707 | 1-128-993-21 | ELECT CHIP | 22UF | 20% | 10V |
| C218 | 1-124-779-21 | ELECT CHIP | 10UF | 20.00% | 16V | | | | | | |
| C219 | 1-162-970-91 | CERAMIC CHIP | 0.01UF | 10.00% | 25V | C709 | 1-107-826-91 | CERAMIC CHIP | 0.1UF | 10.00% | 16V |
| C220 | 1-124-779-21 | ELECT CHIP | 10UF | 20.00% | 16V | C710 | 1-124-779-21 | ELECT CHIP | 10UF | 20.00% | 16V |
| C221 | 1-107-826-91 | CERAMIC CHIP | 0.1UF | 10.00% | 16V | C711 | 1-107-826-91 | CERAMIC CHIP | 0.1UF | 10.00% | 16V |
| C222 | 1-107-826-91 | CERAMIC CHIP | 0.1UF | 10.00% | 16V | C712 | 1-107-826-91 | CERAMIC CHIP | 0.1UF | 10.00% | 16V |
| C223 | 1-107-826-91 | CERAMIC CHIP | 0.1UF | 10.00% | 16V | C713 | 1-164-172-91 | CERAMIC CHIP | 0.0056UF | 10.00% | 25V |
| C224 | 1-162-970-91 | CERAMIC CHIP | 0.01UF | 10.00% | 25V | | | | | | |
| C225 | 1-162-964-91 | CERAMIC CHIP | 0.001UF | 10.00% | 50V | C714 | 1-107-826-91 | CERAMIC CHIP | 0.1UF | 10.00% | 16V |
| C226 | 1-162-964-91 | CERAMIC CHIP | 0.001UF | 10.00% | 50V | C715 | 1-128-994-21 | ELECT CHIP | 47UF | 20% | 10V |
| C233 | 1-162-968-91 | CERAMIC CHIP | 0.0047UF | 10.00% | 50V | C716 | 1-127-715-91 | CERAMIC CHIP | 0.22UF | 10% | 16V |
| C301 | 1-107-826-91 | CERAMIC CHIP | 0.1UF | 10.00% | 16V | C717 | 1-162-970-91 | CERAMIC CHIP | 0.01UF | 10.00% | 25V |
| C310 | 1-128-994-21 | ELECT CHIP | 47UF | 20% | 10V | C718 | 1-162-970-91 | CERAMIC CHIP | 0.01UF | 10.00% | 25V |
| C311 | 1-107-826-91 | CERAMIC CHIP | 0.1UF | 10.00% | 16V | | | | | | |
| C312 | 1-107-826-91 | CERAMIC CHIP | 0.1UF | 10.00% | 16V | C719 | 1-127-715-91 | CERAMIC CHIP | 0.22UF | 10% | 16V |
| C313 | 1-128-994-21 | ELECT CHIP | 47UF | 20% | 10V | C720 | 1-127-715-91 | CERAMIC CHIP | 0.22UF | 10% | 16V |
| C314 | 1-107-826-91 | CERAMIC CHIP | 0.1UF | 10.00% | 16V | C723 | 1-127-715-91 | CERAMIC CHIP | 0.22UF | 10% | 16V |
| C401 | 1-164-739-91 | CERAMIC CHIP | 560PF | 5.00% | 50V | C725 | 1-162-970-91 | CERAMIC CHIP | 0.01UF | 10.00% | 25V |
| C402 | 1-164-739-91 | CERAMIC CHIP | 560PF | 5.00% | 50V | C726 | 1-107-826-91 | CERAMIC CHIP | 0.1UF | 10.00% | 16V |
| C403 | 1-164-218-91 | CERAMIC CHIP | 180PF | 5.00% | 50V | | | | | | |
| C404 | 1-164-218-91 | CERAMIC CHIP | 180PF | 5.00% | 50V | C727 | 1-162-970-91 | CERAMIC CHIP | 0.01UF | 10.00% | 25V |
| C405 | 1-164-218-91 | CERAMIC CHIP | 180PF | 5.00% | 50V | C729 | 1-127-715-91 | CERAMIC CHIP | 0.22UF | 10% | 16V |
| C406 | 1-164-218-91 | CERAMIC CHIP | 180PF | 5.00% | 50V | C730 | 1-127-715-91 | CERAMIC CHIP | 0.22UF | 10% | 16V |
| C407 | 1-162-970-91 | CERAMIC CHIP | 0.01UF | 10.00% | 25V | C731 | 1-128-993-21 | ELECT CHIP | 22UF | 20% | 10V |
| C408 | 1-162-970-91 | CERAMIC CHIP | 0.01UF | 10.00% | 25V | C732 | 1-162-970-91 | CERAMIC CHIP | 0.01UF | 10.00% | 25V |
| C409 | 1-126-193-21 | ELECT CHIP | 1UF | 20.00% | 50V | | | | | | |
| C410 | 1-126-204-21 | ELECT CHIP | 47UF | 20.00% | 16V | C733 | 1-162-970-91 | CERAMIC CHIP | 0.01UF | 10.00% | 25V |
| C411 | 1-126-204-21 | ELECT CHIP | 47UF | 20.00% | 16V | C734 | 1-162-970-91 | CERAMIC CHIP | 0.01UF | 10.00% | 25V |
| C412 | 1-126-193-21 | ELECT CHIP | 1UF | 20.00% | 50V | C736 | 1-126-208-21 | ELECT CHIP | 47UF | 20.00% | 4V |
| C413 | 1-117-681-21 | ELECT CHIP | 100UF | 20.00% | 16V | C1101 | 1-162-964-91 | CERAMIC CHIP | 0.001UF | 10.00% | 50V |
| C415 | 1-164-230-91 | CERAMIC CHIP | 220PF | 5.00% | 50V | C1103 | 1-162-964-91 | CERAMIC CHIP | 0.001UF | 10.00% | 50V |
| C416 | 1-164-230-91 | CERAMIC CHIP | 220PF | 5.00% | 50V | | | | | | |
| C422 | 1-107-826-91 | CERAMIC CHIP | 0.1UF | 10.00% | 16V | C1104 | 1-162-964-91 | CERAMIC CHIP | 0.001UF | 10.00% | 50V |
| C425 | 1-162-970-91 | CERAMIC CHIP | 0.01UF | 10.00% | 25V | C1106 | 1-162-964-91 | CERAMIC CHIP | 0.001UF | 10.00% | 50V |
| C427 | 1-128-994-21 | ELECT CHIP | 47UF | 20% | 10V | C1107 | 1-162-964-91 | CERAMIC CHIP | 0.001UF | 10.00% | 50V |
| C428 | 1-124-779-21 | ELECT CHIP | 10UF | 20.00% | 16V | | | | | | |
| C429 | 1-124-779-21 | ELECT CHIP | 10UF | 20.00% | 16V | | | | | | |
| C432 | 1-162-964-91 | CERAMIC CHIP | 0.001UF | 10.00% | 50V | | | | | | |
| C433 | 1-127-715-91 | CERAMIC CHIP | 0.22UF | 10% | 16V | | | | | | |
| C434 | 1-124-779-21 | ELECT CHIP | 10UF | 20.00% | 16V | | | | | | |
| C435 | 1-162-970-91 | CERAMIC CHIP | 0.01UF | 10.00% | 25V | | | | | | |
| C444 | 1-126-204-21 | ELECT CHIP | 47UF | 20.00% | 16V | | | | | | |
| C445 | 1-117-681-21 | ELECT CHIP | 100UF | 20.00% | 16V | | | | | | |
| | | | | | | | | <CONNECTOR> | | | |
| | | | | | | * CN105 | 1-770-470-21 | PIN, CONNECTOR (PC BOARD) 6P | | | |
| | | | | | | * CN201 | 1-770-470-21 | PIN, CONNECTOR (PC BOARD) 6P | | | |
| | | | | | | * CN601 | 1-770-468-21 | PIN, CONNECTOR (PC BOARD) 10P | | | |
| | | | | | | CN604 | 1-573-290-21 | PIN, CONNECTOR (1.5MM) (SMD) 4P | | | |
| | | | | | | | | (DVP-NS76H:AEP,UK,RUS ONLY) | | | |
| | | | | | | CN1701 | 1-573-806-21 | PIN, CONNECTOR (1.5MM) (SMD) 6P | | | |
| | | | | | | | | | | | |
| | | | | | | | | <DIODE> | | | |
| | | | | | | D308 | 8-719-071-15 | DIODE HZM6.8ZWA1TL | | | |
| | | | | | | D309 | 8-719-071-15 | DIODE HZM6.8ZWA1TL | | | |
| | | | | | | D310 | 8-719-988-61 | DIODE 1SS355TE-17 (NS76H:AEP,UK,RUS ONLY) | | | |

MV

| Ref. No. | Part No. | Description | Remark |
|-----------|--------------|---|--------|
| D401 | 8-719-914-43 | DIODE DAN202K | |
| D402 | 8-719-914-44 | DIODE DAP202K | |
| D403 | 8-719-914-44 | DIODE DAP202K (DVP-NS76H:AEP,UK,RUS ONLY) | |
| D404 | 8-719-988-61 | DIODE 1SS355TE-17 | |
| <FERRITE> | | | |
| FB106 | 1-469-324-21 | FERRITE | OUH |
| FB107 | 1-469-324-21 | FERRITE | OUH |
| FB108 | 1-469-324-21 | FERRITE | OUH |
| FB111 | 1-469-670-21 | FERRITE | OUH |
| FB112 | 1-469-670-21 | FERRITE | OUH |
| FB115 | 1-469-670-21 | FERRITE | OUH |
| FB116 | 1-414-226-21 | FERRITE | OUH |
| FB117 | 1-469-118-21 | FERRITE | OUH |
| FB118 | 1-469-118-21 | FERRITE | OUH |
| FB119 | 1-469-118-21 | FERRITE | OUH |
| FB120 | 1-469-118-21 | FERRITE | OUH |
| FB121 | 1-469-118-21 | FERRITE | OUH |
| FB122 | 1-469-118-21 | FERRITE | OUH |
| FB123 | 1-469-324-21 | FERRITE | OUH |
| FB124 | 1-469-118-21 | FERRITE | OUH |
| FB125 | 1-469-118-21 | FERRITE | OUH |
| FB126 | 1-469-118-21 | FERRITE | OUH |
| FB129 | 1-469-118-21 | FERRITE | OUH |
| FB501 | 1-469-118-21 | FERRITE | OUH |
| | | (NS76H:AEP,UK,RUS ONLY) | |
| FB502 | 1-469-118-21 | FERRITE | OUH |
| | | (NS76H:AEP,UK,RUS ONLY) | |
| FB503 | 1-469-118-21 | FERRITE | OUH |
| | | (NS76H:AEP,UK,RUS ONLY) | |
| FB601 | 1-469-324-21 | FERRITE | OUH |
| FB602 | 1-469-324-21 | FERRITE | OUH |
| FB603 | 1-469-324-21 | FERRITE | OUH |
| FB605 | 1-469-324-21 | FERRITE | OUH |
| FB606 | 1-469-324-21 | FERRITE | OUH |
| FL601 | 1-234-177-21 | FERRITE | OUH |
| FL602 | 1-233-893-21 | FILTER, CHIP EMI | |
| FL603 | 1-234-177-21 | FERRITE | OUH |
| FL701 | 1-234-494-21 | FILTER, EMI REMOVAL (SMD) | |
| FL703 | 1-234-494-21 | FILTER, EMI REMOVAL (SMD) | |
| FL704 | 1-234-494-21 | FILTER, EMI REMOVAL (SMD) | |
| FL705 | 1-234-494-21 | FILTER, EMI REMOVAL (SMD) | |

| Ref. No. | Part No. | Description | Remark |
|---|--------------|--------------------------|--------|
| <IC> | | | |
| Notes: MV-49 mounted PWB must be replaced if IC103 (EEPROM) is damaged or not functioning. The old MV-49 mounted PWB must be completely destroyed before disposal, as required by CPRM-key regulation. | | | |
| Notes: Special key has been written in the IC706 (HDCP key) and therefore the IC706 cannot be replaced. If this IC is faulty, replace the board entirely. | | | |
| IC101 | 6-706-727-01 | IC CXD9804R | |
| IC102 | | IC(ROM) | |
| IC103 | SEE NOTE | | |
| IC104 | 6-707-897-01 | IC EDS6416AHTA-75-E | |
| IC105 | 6-702-302-01 | IC TK11133CSCL-G | |
| IC107 | 6-702-302-01 | IC TK11133CSCL-G | |
| IC108 | 6-703-224-01 | IC S-80828CNNB-B8NT2G | |
| IC110 | 6-707-739-01 | IC MM1661JTRE | |
| IC201 | 6-704-524-01 | IC FAN8036L | |
| IC303 | 8-759-667-17 | IC L79M05TLL-SONY-TL-E | |
| IC304 | 6-706-453-01 | IC NJM2587V(TE2) | |
| IC401 | 6-707-187-01 | IC HA17558AFEL-E | |
| IC403 | 6-706-025-01 | IC HA178L05UA-TL-E | |
| IC404 | 6-600-431-01 | ICGP1FAV50TK0F | |
| IC406 | 6-707-490-01 | IC AK4385ET-E2 | |
| IC701 | 6-708-682-01 | IC CXD9873Q | |
| IC702 | 6-702-300-01 | IC TK11118CSCL-G | |
| IC703 | 6-702-302-01 | IC TK11133CSCL-G | |
| IC705 | 6-703-046-01 | IC SN74LVC1G08DCKR | |
| IC706 | | SEE NOTE | |
| IC707 | 6-705-337-01 | IC TK11150CSCL-G | |
| IC708 | 6-806-400-01 | IC MB95F108SPFV-GE1-E001 | |
| <INDUCTOR> | | | |
| * LF701 | 1-813-308-11 | INDUCTOR | OUH |
| * LF702 | 1-813-308-11 | INDUCTOR | OUH |
| * LF703 | 1-813-308-11 | INDUCTOR | OUH |
| * LF704 | 1-813-308-11 | INDUCTOR | OUH |
| <FUSE> | | | |
| △ PS601 | 1-576-892-11 | FUSE | 1A 32V |
| △ PS602 | 1-576-892-11 | FUSE | 1A 32V |

Note :
 The components identified by mark △ or dotted line with mark △ are critical for safety. Replace only with part number specified.

| Ref. No. | Part No. | Description | Remark | Ref. No. | Part No. | Description | Remark |
|----------|--------------|--------------------------------|--------|----------|--------------|-------------------------|--------|
| | | <TRANSISTOR> | | R142 | 1-216-845-91 | METAL CHIP 100K 5% | 1/10W |
| Q101 | 6-550-008-01 | TRANSISTOR UM6K1N-TN | | R144 | 1-216-864-91 | SHORT CHIP 0 | |
| Q102 | 6-550-653-01 | TRANSISTOR QST8TR | | | | (NS76H:AEP,UK,RUS ONLY) | |
| Q103 | 8-729-424-63 | TRANSISTOR UN2212-TX | | R145 | 1-216-864-91 | SHORT CHIP 0 | |
| Q304 | 8-729-024-89 | TRANSISTOR MUN2213T1 | | R146 | 1-216-805-91 | METAL CHIP 47 5% | 1/10W |
| Q305 | 8-729-024-83 | TRANSISTOR MUN2111T1 | | R147 | 1-216-864-91 | SHORT CHIP 0 | |
| Q401 | 8-729-010-10 | TRANSISTOR MSB710-RT1 | | R148 | 1-216-864-91 | SHORT CHIP 0 | |
| Q402 | 8-729-024-89 | TRANSISTOR MUN2213T1 | | R151 | 1-216-833-91 | METAL CHIP 10K 5% | 1/10W |
| Q403 | 8-729-010-25 | TRANSISTOR MSD601-RT1 | | R152 | 1-216-864-91 | SHORT CHIP 0 | |
| Q404 | 8-729-424-72 | TRANSISTOR UN2217-QRS-TX | | R153 | 1-216-864-91 | SHORT CHIP 0 | |
| Q405 | 8-729-010-05 | TRANSISTOR MSB709-RT1 | | R154 | 1-216-864-91 | SHORT CHIP 0 | |
| Q406 | 8-729-024-89 | TRANSISTOR MUN2213T1 | | R155 | 1-216-864-91 | SHORT CHIP 0 | |
| | | (DVP-NS76H:AEP,UK,RUS ONLY) | | R156 | 1-216-809-91 | METAL CHIP 100 5% | 1/10W |
| Q407 | 6-550-137-01 | TRANSISTOR2SD1938(F)-ST(TX).SO | | R158 | 1-216-809-91 | METAL CHIP 100 5% | 1/10W |
| Q408 | 6-550-137-01 | TRANSISTOR2SD1938(F)-ST(TX).SO | | R159 | 1-216-805-91 | METAL CHIP 47 5% | 1/10W |
| Q409 | 8-729-424-72 | TRANSISTOR UN2217-QRS-TX | | R160 | 1-216-805-91 | METAL CHIP 47 5% | 1/10W |
| | | (DVP-NS76H:AEP,UK,RUS ONLY) | | R161 | 1-216-805-91 | METAL CHIP 47 5% | 1/10W |
| Q410 | 8-729-010-05 | TRANSISTOR MSB709-RT1 | | R162 | 1-216-864-91 | SHORT CHIP 0 | |
| | | (DVP-NS76H:AEP,UK,RUS ONLY) | | R164 | 1-216-864-91 | SHORT CHIP 0 | |
| Q411 | 8-729-010-25 | TRANSISTOR MSD601-RT1 | | R166 | 1-216-864-91 | SHORT CHIP 0 | |
| Q416 | 8-729-010-05 | TRANSISTOR MSB709-RT1 | | R169 | 1-216-864-91 | SHORT CHIP 0 | |
| Q601 | 6-551-458-01 | TRANSISTOR KTD1624-B | | R171 | 1-216-809-91 | METAL CHIP 100 5% | 1/10W |
| Q602 | 8-729-424-08 | TRANSISTOR UN2111 | | R172 | 1-216-864-91 | SHORT CHIP 0 | |
| Q701 | 8-729-012-58 | TRANSISTOR 2SK1399-T1B | | R173 | 1-216-864-91 | SHORT CHIP 0 | |
| Q702 | 8-729-012-58 | TRANSISTOR 2SK1399-T1B | | R174 | 1-216-864-91 | SHORT CHIP 0 | |
| | | <RESISTOR> | | R175 | 1-216-864-91 | SHORT CHIP 0 | |
| R101 | 1-216-809-91 | METAL CHIP 100 5% | 1/10W | R183 | 1-216-805-91 | METAL CHIP 47 5% | 1/10W |
| R102 | 1-216-295-91 | SHORT CHIP 0 | | R184 | 1-216-805-91 | METAL CHIP 47 5% | 1/10W |
| R103 | 1-216-864-91 | SHORT CHIP 0 | | R185 | 1-216-805-91 | METAL CHIP 47 5% | 1/10W |
| R106 | 1-216-833-91 | METAL CHIP 10K 5% | 1/10W | R189 | 1-218-827-91 | METAL CHIP 150 0.5% | 1/10W |
| R107 | 1-216-833-91 | METAL CHIP 10K 5% | 1/10W | R190 | 1-218-827-91 | METAL CHIP 150 0.5% | 1/10W |
| R108 | 1-216-857-91 | METAL CHIP 1M 5% | 1/10W | R191 | 1-216-821-91 | METAL CHIP 1K 5% | 1/10W |
| R109 | 1-216-864-91 | SHORT CHIP 0 | | R192 | 1-218-827-91 | METAL CHIP 150 0.5% | 1/10W |
| R110 | 1-216-841-91 | METAL CHIP 47K 5% | 1/10W | R193 | 1-216-821-91 | METAL CHIP 1K 5% | 1/10W |
| R111 | 1-216-809-91 | METAL CHIP 100 5% | 1/10W | R195 | 1-218-827-91 | METAL CHIP 150 0.5% | 1/10W |
| R112 | 1-211-977-91 | METAL CHIP 22 0.5% | 1/10W | R204 | 1-216-822-91 | METAL CHIP 1.2K 5% | 1/10W |
| R113 | 1-211-977-91 | METAL CHIP 22 0.5% | 1/10W | R205 | 1-216-833-91 | METAL CHIP 10K 5% | 1/10W |
| R114 | 1-216-845-91 | METAL CHIP 100K 5% | 1/10W | R206 | 1-216-833-91 | METAL CHIP 10K 5% | 1/10W |
| R115 | 1-211-977-91 | METAL CHIP 22 0.5% | 1/10W | R207 | 1-216-826-91 | METAL CHIP 2.7K 5% | 1/10W |
| R116 | 1-216-821-91 | METAL CHIP 1K 5% | 1/10W | R208 | 1-216-839-91 | METAL CHIP 33K 5% | 1/10W |
| R117 | 1-216-841-91 | METAL CHIP 47K 5% | 1/10W | R209 | 1-216-839-91 | METAL CHIP 33K 5% | 1/10W |
| R118 | 1-216-801-91 | METAL CHIP 22 5% | 1/10W | R210 | 1-216-841-91 | METAL CHIP 47K 5% | 1/10W |
| R120 | 1-216-801-91 | METAL CHIP 22 5% | 1/10W | R212 | 1-216-833-91 | METAL CHIP 10K 5% | 1/10W |
| R121 | 1-216-801-91 | METAL CHIP 22 5% | 1/10W | R213 | 1-218-867-11 | RES, CHIP 6.8K (1608) | |
| R123 | 1-216-864-91 | SHORT CHIP 0 | | R214 | 1-216-835-91 | METAL CHIP 15K 5% | 1/10W |
| R124 | 1-216-841-91 | METAL CHIP 47K 5% | 1/10W | R215 | 1-216-834-91 | METAL CHIP 12K 5% | 1/10W |
| R132 | 1-216-845-91 | METAL CHIP 100K 5% | 1/10W | R216 | 1-216-834-91 | METAL CHIP 12K 5% | 1/10W |
| R133 | 1-216-864-91 | SHORT CHIP 0 | | R219 | 1-216-838-91 | METAL CHIP 27K 5% | 1/10W |
| R134 | 1-216-864-91 | SHORT CHIP 0 | | R220 | 1-216-821-91 | METAL CHIP 1K 5% | 1/10W |
| R135 | 1-216-833-91 | METAL CHIP 10K 5% | 1/10W | R221 | 1-218-889-91 | METAL CHIP 56K 0.5% | 1/10W |
| R136 | 1-216-835-91 | METAL CHIP 15K 5% | 1/10W | R222 | 1-216-839-91 | METAL CHIP 33K 5% | 1/10W |
| R137 | 1-216-864-91 | SHORT CHIP 0 | | R223 | 1-218-895-91 | METAL CHIP 100K 0.5% | 1/10W |
| | | (NS76H:AEP,UK,RUS ONLY) | | R224 | 1-216-833-91 | METAL CHIP 10K 5% | 1/10W |
| R138 | 1-216-809-91 | METAL CHIP 100 5% | 1/10W | R225 | 1-218-895-91 | METAL CHIP 100K 0.5% | 1/10W |
| R139 | 1-216-864-91 | SHORT CHIP 0 | | R226 | 1-218-889-91 | METAL CHIP 56K 0.5% | 1/10W |
| R140 | 1-216-833-91 | METAL CHIP 10K 5% | 1/10W | R227 | 1-216-864-91 | SHORT CHIP 0 | |
| R141 | 1-216-855-91 | METAL CHIP 680K 5% | 1/10W | R228 | 1-216-864-91 | SHORT CHIP 0 | |
| | | | | R230 | 1-218-893-91 | METAL CHIP 82K 0.5% | 1/10W |
| | | | | R231 | 1-218-875-91 | METAL CHIP 15K 0.5% | 1/10W |

MV

| Ref. No. | Part No. | Description | | | Remark | Ref. No. | Part No. | Description | | | Remark |
|----------|--------------|--------------------------------|------|------|--------|----------|--------------|--------------------------------|------|----|--------|
| R232 | 1-218-877-91 | METAL CHIP | 18K | 0.5% | 1/10W | R427 | 1-216-817-91 | METAL CHIP | 470 | 5% | 1/10W |
| R233 | 1-218-883-91 | METAL CHIP | 33K | 0.5% | 1/10W | R428 | 1-216-833-91 | METAL CHIP | 10K | 5% | 1/10W |
| R234 | 1-216-833-91 | METAL CHIP | 10K | 5% | 1/10W | R429 | 1-216-841-91 | METAL CHIP | 47K | 5% | 1/10W |
| R236 | 1-216-821-91 | METAL CHIP | 1K | 5% | 1/10W | R431 | 1-216-833-91 | METAL CHIP | 10K | 5% | 1/10W |
| R237 | 1-216-821-91 | METAL CHIP | 1K | 5% | 1/10W | | | (NS76H:AEP,UK,RUS ONLY) | | | |
| R238 | 1-216-829-91 | METAL CHIP | 4.7K | 5% | 1/10W | R432 | 1-216-833-91 | METAL CHIP | 10K | 5% | 1/10W |
| R239 | 1-216-829-91 | METAL CHIP | 4.7K | 5% | 1/10W | | | (NS76H:AEP,UK,RUS ONLY) | | | |
| R243 | 1-216-809-91 | METAL CHIP | 100 | 5% | 1/10W | R433 | 1-216-841-91 | METAL CHIP | 47K | 5% | 1/10W |
| R246 | 1-216-829-91 | METAL CHIP | 4.7K | 5% | 1/10W | | | (NS76H:AEP,UK,RUS ONLY) | | | |
| R247 | 1-216-821-91 | METAL CHIP | 1K | 5% | 1/10W | R434 | 1-216-829-91 | METAL CHIP | 4.7K | 5% | 1/10W |
| R320 | 1-216-864-91 | SHORT CHIP | 0 | | | R435 | 1-216-829-91 | METAL CHIP | 4.7K | 5% | 1/10W |
| | | (EXCEPT NS76H:AEP,UK,RUS ONLY) | | | | | | (EXCEPT NS76H:AEP,UK,RUS ONLY) | | | |
| R320 | 1-216-833-91 | METAL CHIP | 10K | 5% | 1/10W | R436 | 1-216-833-91 | METAL CHIP | 10K | 5% | 1/10W |
| | | (NS76H:AEP,UK,RUS ONLY) | | | | | | (NS76H:AEP,UK,RUS ONLY) | | | |
| R321 | 1-216-833-91 | METAL CHIP | 10K | 5% | 1/10W | R437 | 1-216-829-91 | METAL CHIP | 4.7K | 5% | 1/10W |
| R322 | 1-216-864-91 | SHORT CHIP | 0 | | | | | (NS76H:AEP,UK,RUS ONLY) | | | |
| R325 | 1-216-864-91 | SHORT CHIP | 0 | | | R438 | 1-216-845-91 | METAL CHIP | 100K | 5% | 1/10W |
| R327 | 1-216-833-91 | METAL CHIP | 10K | 5% | 1/10W | R439 | 1-216-845-91 | METAL CHIP | 100K | 5% | 1/10W |
| R331 | 1-211-990-91 | METAL CHIP | 75 | 0.5% | 1/10W | | | (NS76H:AEP,UK,RUS ONLY) | | | |
| R333 | 1-211-990-91 | METAL CHIP | 75 | 0.5% | 1/10W | R440 | 1-216-817-91 | METAL CHIP | 470 | 5% | 1/10W |
| R334 | 1-211-990-91 | METAL CHIP | 75 | 0.5% | 1/10W | R441 | 1-216-817-91 | METAL CHIP | 470 | 5% | 1/10W |
| R335 | 1-211-990-91 | METAL CHIP | 75 | 0.5% | 1/10W | R442 | 1-216-864-91 | SHORT CHIP | 0 | | |
| R336 | 1-211-990-91 | METAL CHIP | 75 | 0.5% | 1/10W | R443 | 1-216-864-91 | SHORT CHIP | 0 | | |
| R347 | 1-216-864-91 | SHORT CHIP | 0 | | | R444 | 1-216-809-91 | METAL CHIP | 100 | 5% | 1/10W |
| R348 | 1-216-864-91 | SHORT CHIP | 0 | | | R449 | 1-216-813-91 | METAL CHIP | 220 | 5% | 1/10W |
| R349 | 1-216-864-91 | SHORT CHIP | 0 | | | R451 | 1-216-807-91 | METAL CHIP | 68 | 5% | 1/10W |
| R350 | 1-216-864-91 | SHORT CHIP | 0 | | | R452 | 1-216-833-91 | METAL CHIP | 10K | 5% | 1/10W |
| R351 | 1-216-864-91 | SHORT CHIP | 0 | | | R453 | 1-216-821-91 | METAL CHIP | 1K | 5% | 1/10W |
| R388 | 1-216-864-91 | SHORT CHIP | 0 | | | R454 | 1-216-821-91 | METAL CHIP | 1K | 5% | 1/10W |
| R389 | 1-216-864-91 | SHORT CHIP | 0 | | | R456 | 1-216-821-91 | METAL CHIP | 1K | 5% | 1/10W |
| R390 | 1-216-864-91 | SHORT CHIP | 0 | | | R463 | 1-216-833-91 | METAL CHIP | 10K | 5% | 1/10W |
| R393 | 1-216-864-91 | SHORT CHIP | 0 | | | R468 | 1-216-864-91 | SHORT CHIP | 0 | | |
| R394 | 1-216-864-91 | SHORT CHIP | 0 | | | R475 | 1-216-295-91 | SHORT CHIP | 0 | | |
| R398 | 1-216-295-91 | SHORT CHIP | 0 | | | R476 | 1-216-295-91 | SHORT CHIP | 0 | | |
| R399 | 1-216-295-91 | SHORT CHIP | 0 | | | R484 | 1-216-830-91 | METAL CHIP | 5.6K | 5% | 1/10W |
| R401 | 1-208-799-91 | METAL CHIP | 5.1K | 0.5% | 1/10W | R529 | 1-216-295-91 | SHORT CHIP | 0 | | |
| R402 | 1-208-799-91 | METAL CHIP | 5.1K | 0.5% | 1/10W | R541 | 1-216-864-91 | SHORT CHIP | 0 | | |
| R403 | 1-208-799-91 | METAL CHIP | 5.1K | 0.5% | 1/10W | | | (NS76H:AEP,UK,RUS ONLY) | | | |
| R404 | 1-208-799-91 | METAL CHIP | 5.1K | 0.5% | 1/10W | R542 | 1-216-864-91 | SHORT CHIP | 0 | | |
| R405 | 1-208-800-91 | METAL CHIP | 5.6K | 0.5% | 1/10W | | | (NS76H:AEP,UK,RUS ONLY) | | | |
| R406 | 1-208-800-91 | METAL CHIP | 5.6K | 0.5% | 1/10W | R543 | 1-216-864-91 | SHORT CHIP | 0 | | |
| R407 | 1-216-825-91 | METAL CHIP | 2.2K | 5% | 1/10W | | | (NS76H:AEP,UK,RUS ONLY) | | | |
| R408 | 1-216-825-91 | METAL CHIP | 2.2K | 5% | 1/10W | R544 | 1-216-864-91 | SHORT CHIP | 0 | | |
| R409 | 1-216-825-91 | METAL CHIP | 2.2K | 5% | 1/10W | | | (NS76H:AEP,UK,RUS ONLY) | | | |
| R410 | 1-216-825-91 | METAL CHIP | 2.2K | 5% | 1/10W | R601 | 1-216-833-91 | METAL CHIP | 10K | 5% | 1/10W |
| R411 | 1-208-800-91 | METAL CHIP | 5.6K | 0.5% | 1/10W | R602 | 1-216-827-91 | METAL CHIP | 3.3K | 5% | 1/10W |
| R412 | 1-208-800-91 | METAL CHIP | 5.6K | 0.5% | 1/10W | R603 | 1-216-827-91 | METAL CHIP | 3.3K | 5% | 1/10W |
| R413 | 1-216-829-91 | METAL CHIP | 4.7K | 5% | 1/10W | R604 | 1-216-827-91 | METAL CHIP | 3.3K | 5% | 1/10W |
| R414 | 1-216-829-91 | METAL CHIP | 4.7K | 5% | 1/10W | R605 | 1-216-864-91 | SHORT CHIP | 0 | | |
| | | (NS76H:AEP,UK,RUS ONLY) | | | | R701 | 1-216-864-91 | SHORT CHIP | 0 | | |
| R416 | 1-216-830-91 | METAL CHIP | 5.6K | 5% | 1/10W | R702 | 1-216-864-91 | SHORT CHIP | 0 | | |
| R417 | 1-216-833-91 | METAL CHIP | 10K | 5% | 1/10W | R703 | 1-216-864-91 | SHORT CHIP | 0 | | |
| R418 | 1-216-845-91 | METAL CHIP | 100K | 5% | 1/10W | R704 | 1-216-864-91 | SHORT CHIP | 0 | | |
| R419 | 1-216-849-91 | METAL CHIP | 220K | 5% | 1/10W | R705 | 1-216-829-91 | METAL CHIP | 4.7K | 5% | 1/10W |
| R420 | 1-216-817-91 | METAL CHIP | 470 | 5% | 1/10W | R708 | 1-216-821-91 | METAL CHIP | 1K | 5% | 1/10W |
| R421 | 1-216-833-91 | METAL CHIP | 10K | 5% | 1/10W | R709 | 1-216-821-91 | METAL CHIP | 1K | 5% | 1/10W |
| R422 | 1-216-833-91 | METAL CHIP | 10K | 5% | 1/10W | R712 | 1-216-809-91 | METAL CHIP | 100 | 5% | 1/10W |
| R424 | 1-216-833-91 | METAL CHIP | 10K | 5% | 1/10W | R714 | 1-216-864-91 | SHORT CHIP | 0 | | |
| R425 | 1-216-841-91 | METAL CHIP | 47K | 5% | 1/10W | R718 | 1-216-829-91 | METAL CHIP | 4.7K | 5% | 1/10W |
| R426 | 1-216-817-91 | METAL CHIP | 470 | 5% | 1/10W | R722 | 1-216-833-91 | METAL CHIP | 10K | 5% | 1/10W |
| | | | | | | R723 | 1-216-833-91 | METAL CHIP | 10K | 5% | 1/10W |

| Ref. No. | Part No. | Description | | | Remark | Ref. No. | Part No. | Description | | | Remark |
|----------|--------------|-------------|------|------|--------|----------|--------------|-----------------------------|------|----|--------|
| R724 | 1-216-864-91 | SHORT CHIP | 0 | | | R1146 | 1-216-295-91 | SHORT CHIP | 0 | | |
| R725 | 1-216-864-91 | SHORT CHIP | 0 | | | R1147 | 1-216-295-91 | SHORT CHIP | 0 | | |
| R728 | 1-216-864-91 | SHORT CHIP | 0 | | | R1150 | 1-216-827-91 | METAL CHIP | 3.3K | 5% | 1/10W |
| R730 | 1-218-840-91 | METAL CHIP | 510 | 0.5% | 1/10W | R1151 | 1-216-827-91 | METAL CHIP | 3.3K | 5% | 1/10W |
| R731 | 1-216-864-91 | SHORT CHIP | 0 | | | R1152 | 1-216-827-91 | METAL CHIP | 3.3K | 5% | 1/10W |
| R734 | 1-216-864-91 | SHORT CHIP | 0 | | | R1167 | 1-216-864-91 | SHORT CHIP | 0 | | |
| R736 | 1-216-864-91 | SHORT CHIP | 0 | | | R1168 | 1-216-813-91 | METAL CHIP | 220 | 5% | 1/10W |
| R738 | 1-216-864-91 | SHORT CHIP | 0 | | | R1169 | 1-216-805-91 | METAL CHIP | 47 | 5% | 1/10W |
| R740 | 1-216-864-91 | SHORT CHIP | 0 | | | R1170 | 1-216-864-91 | SHORT CHIP | 0 | | |
| R742 | 1-216-841-91 | METAL CHIP | 47K | 5% | 1/10W | R1172 | 1-216-864-91 | SHORT CHIP | 0 | | |
| R743 | 1-216-821-91 | METAL CHIP | 1K | 5% | 1/10W | R1173 | 1-216-295-91 | SHORT CHIP | 0 | | |
| R744 | 1-216-829-91 | METAL CHIP | 4.7K | 5% | 1/10W | R1177 | 1-216-809-91 | METAL CHIP | 100 | 5% | 1/10W |
| R745 | 1-216-821-91 | METAL CHIP | 1K | 5% | 1/10W | R1178 | 1-216-821-91 | METAL CHIP | 1K | 5% | 1/10W |
| R747 | 1-216-864-91 | SHORT CHIP | 0 | | | R1179 | 1-216-809-91 | METAL CHIP | 100 | 5% | 1/10W |
| R748 | 1-216-864-91 | SHORT CHIP | 0 | | | R1181 | 1-216-864-91 | SHORT CHIP | 0 | | |
| R749 | 1-216-824-91 | METAL CHIP | 1.8K | 5% | 1/10W | R1183 | 1-216-805-91 | METAL CHIP | 47 | 5% | 1/10W |
| R750 | 1-216-824-91 | METAL CHIP | 1.8K | 5% | 1/10W | R1184 | 1-216-809-91 | METAL CHIP | 100 | 5% | 1/10W |
| R751 | 1-216-864-91 | SHORT CHIP | 0 | | | R1185 | 1-216-809-91 | METAL CHIP | 100 | 5% | 1/10W |
| R752 | 1-216-864-91 | SHORT CHIP | 0 | | | R1186 | 1-216-864-91 | SHORT CHIP | 0 | | |
| R753 | 1-216-864-91 | SHORT CHIP | 0 | | | R1187 | 1-216-864-91 | SHORT CHIP | 0 | | |
| R754 | 1-216-833-91 | METAL CHIP | 0 | | | R1191 | 1-216-864-91 | SHORT CHIP | 0 | | |
| R759 | 1-216-864-91 | SHORT CHIP | 0 | | | R1701 | 1-216-864-91 | SHORT CHIP | 0 | | |
| R760 | 1-216-809-91 | METAL CHIP | 100 | 5% | 1/10W | R1702 | 1-216-864-91 | SHORT CHIP | 0 | | |
| R762 | 1-216-864-91 | SHORT CHIP | 0 | | | R1703 | 1-216-864-91 | SHORT CHIP | 0 | | |
| R763 | 1-216-864-91 | SHORT CHIP | 0 | | | R1705 | 1-216-821-91 | METAL CHIP | 1K | 5% | 1/10W |
| R764 | 1-216-829-91 | METAL CHIP | 4.7K | 5% | 1/10W | R1706 | 1-216-821-91 | METAL CHIP | 1K | 5% | 1/10W |
| R765 | 1-216-864-91 | SHORT CHIP | 0 | | | R1710 | 1-216-829-91 | METAL CHIP | 4.7K | 5% | 1/10W |
| R766 | 1-216-829-91 | METAL CHIP | 4.7K | 5% | 1/10W | R1711 | 1-216-833-91 | METAL CHIP | 10K | 5% | 1/10W |
| R767 | 1-216-864-91 | SHORT CHIP | 0 | | | R1712 | 1-216-833-91 | METAL CHIP | 10K | 5% | 1/10W |
| R769 | 1-216-864-91 | SHORT CHIP | 0 | | | R1715 | 1-216-864-91 | SHORT CHIP | 0 | | |
| R770 | 1-216-864-91 | SHORT CHIP | 0 | | | | | | | | |
| R771 | 1-216-864-91 | SHORT CHIP | 0 | | | | | <NETWORK> | | | |
| R772 | 1-216-864-91 | SHORT CHIP | 0 | | | | | | | | |
| R773 | 1-216-809-91 | METAL CHIP | 100 | 5% | 1/10W | RB103 | 1-234-400-21 | CONDUCTOR, NETWORK (2010X4) | | | |
| R780 | 1-216-864-91 | SHORT CHIP | 0 | | | RB104 | 1-234-400-21 | CONDUCTOR, NETWORK (2010X4) | | | |
| R781 | 1-216-833-91 | METAL CHIP | 10K | 5% | 1/10W | RB105 | 1-234-371-21 | RES, NETWORK 47 (1005X4) | | | |
| R782 | 1-216-833-91 | METAL CHIP | 10K | 5% | 1/10W | RB106 | 1-234-371-21 | RES, NETWORK 47 (1005X4) | | | |
| R783 | 1-216-864-91 | SHORT CHIP | 0 | | | RB107 | 1-234-400-21 | CONDUCTOR, NETWORK (2010X4) | | | |
| R785 | 1-216-864-91 | SHORT CHIP | 0 | | | RB108 | 1-234-400-21 | CONDUCTOR, NETWORK (2010X4) | | | |
| R786 | 1-216-864-91 | SHORT CHIP | 0 | | | RB109 | 1-234-400-21 | CONDUCTOR, NETWORK (2010X4) | | | |
| R787 | 1-216-829-91 | METAL CHIP | 4.7K | 5% | 1/10W | RB110 | 1-234-400-21 | CONDUCTOR, NETWORK (2010X4) | | | |
| R788 | 1-216-864-91 | SHORT CHIP | 0 | | | RB111 | 1-234-400-21 | CONDUCTOR, NETWORK (2010X4) | | | |
| R789 | 1-216-864-91 | SHORT CHIP | 0 | | | RB112 | 1-234-400-21 | CONDUCTOR, NETWORK (2010X4) | | | |
| R790 | 1-216-829-91 | METAL CHIP | 4.7K | 5% | 1/10W | RB113 | 1-234-400-21 | CONDUCTOR, NETWORK (2010X4) | | | |
| R792 | 1-216-829-91 | METAL CHIP | 4.7K | 5% | 1/10W | RB114 | 1-234-400-21 | CONDUCTOR, NETWORK (2010X4) | | | |
| R793 | 1-216-864-91 | SHORT CHIP | 0 | | | RB115 | 1-234-400-21 | CONDUCTOR, NETWORK (2010X4) | | | |
| R1101 | 1-218-855-91 | METAL CHIP | 2.2K | 0.5% | 1/10W | RB116 | 1-234-371-21 | RES, NETWORK 47 (1005X4) | | | |
| R1102 | 1-218-827-91 | METAL CHIP | 150 | 0.5% | 1/10W | RB117 | 1-234-371-21 | RES, NETWORK 47 (1005X4) | | | |
| R1110 | 1-216-826-91 | METAL CHIP | 2.7K | 5% | 1/10W | | | | | | |
| R1114 | 1-216-801-91 | METAL CHIP | 22 | 5% | 1/10W | | | | | | |
| R1115 | 1-216-864-91 | SHORT CHIP | 0 | | | | | <SWITCH> | | | |
| R1129 | 1-216-845-91 | METAL CHIP | 100K | 5% | 1/10W | S1701 | 1-771-337-21 | SWITCH, SLIDE | | | |
| R1133 | 1-216-864-91 | SHORT CHIP | 0 | | | | | | | | |
| R1134 | 1-216-864-91 | SHORT CHIP | 0 | | | | | | | | |
| R1138 | 1-216-864-91 | SHORT CHIP | 0 | | | | | <CRYSTAL> | | | |
| R1139 | 1-216-864-91 | SHORT CHIP | 0 | | | | | | | | |
| R1140 | 1-216-864-91 | SHORT CHIP | 0 | | | X101 | 1-795-630-11 | VIBRATOR, CRYSTAL | | | |
| R1141 | 1-216-864-91 | SHORT CHIP | 0 | | | X701 | 1-795-244-21 | VIBRATOR, CERAMIC | | | |
| R1142 | 1-216-864-91 | SHORT CHIP | 0 | | | | | | | | |
| R1143 | 1-216-864-91 | SHORT CHIP | 0 | | | | | | | | |
| R1145 | 1-216-295-91 | SHORT CHIP | 0 | | | | | | | | |

SW-470

POWER BLOCK (SRV1838UC)

POWER BLOCK (SRV1839WW)

| Ref. No. | Part No. | Description | Remark | | |
|----------|--------------|-------------------------|--------|--------|-------|
| | | SW-470 BOARD ***** | | | |
| | | <CAPACITOR> | | | |
| C001 | 1-163-021-91 | CERAMIC CHIP | 0.01UF | 10.00% | 50V |
| C002 | 1-126-786-91 | ELECT | 47UF | 20% | 16V |
| | | <CONNECTOR> | | | |
| CN001 | 1-794-473-11 | CONNECTOR, FPC/FFC 9P | | | |
| | | <DIODE> | | | |
| D001 | 6-501-147-01 | DIODE LTL-1MHAE-112A | | | |
| D002 | 6-500-598-01 | DIODE SDLB3DC0A0100-DEF | | | |
| | | <IC> | | | |
| IC001 | 6-600-256-01 | IC GP1UE27SXX0F | | | |
| | | <RESISTOR> | | | |
| JR002 | 1-216-295-91 | SHORT CHIP | 0 | | |
| R028 | 1-216-059-91 | RES-CHIP | 2.7K | 5% | 1/10W |
| R029 | 1-216-071-91 | RES-CHIP | 8.2K | 5% | 1/10W |
| R030 | 1-216-063-91 | RES-CHIP | 3.9K | 5% | 1/10W |
| R031 | 1-216-059-91 | RES-CHIP | 2.7K | 5% | 1/10W |
| R033 | 1-216-025-91 | RES-CHIP | 100 | 5% | 1/10W |
| R034 | 1-216-033-91 | RES-CHIP | 220 | 5% | 1/10W |
| R035 | 1-216-017-91 | RES-CHIP | 47 | 5% | 1/10W |
| | | <SWITCH> | | | |
| S001 | 1-771-410-21 | SWITCH, TACT | | | |
| S002 | 1-771-410-21 | SWITCH, TACT | | | |
| S003 | 1-771-410-21 | SWITCH, TACT | | | |
| S004 | 1-771-410-21 | SWITCH, TACT | | | |
| S005 | 1-771-410-21 | SWITCH, TACT | | | |
| S006 | 1-771-410-21 | SWITCH, TACT | | | |

| Ref. No. | Part No. | Description | Remark |
|----------|--------------|--|--------|
| | | ACCESSORIES ***** | |
| | 1-569-008-22 | ADAPTOR, CONVERSION 2P (NS76H:E) | |
| | 1-751-271-71 | CORD, CONNECTION (AV) (EXCEPT NS76H:AEP) | |
| | 2-662-865-11 | MANUAL, INSTRUCTION (ENGLISH) (NS75H) | |
| | 2-662-865-21 | MANUAL, INSTRUCTION (FRENCH) (NS75H:CND) | |
| | 2-662-865-31 | MANUAL, INSTRUCTION (SPANISH) (NS76H:E) | |
| | 2-662-866-11 | MANUAL, INSTRUCTION (ENGLISH) (NS76H:SP) | |
| | 2-662-866-22 | MANUAL, INSTRUCTION (THAI) (NS76H:SP) | |
| | 2-662-866-32 | MANUAL, INSTRUCTION (KOREAN) (NS76H:KR) | |
| | 2-666-955-11 | MANUAL, INSTRUCTION (GERMAN) (NS76H:AE1) | |
| | 2-666-955-21 | MANUAL, INSTRUCTION (FRENCH) (NS76H:AE1) | |
| | 2-666-955-31 | MANUAL, INSTRUCTION (DUTCH) (NS76H:AE1) | |
| | 2-666-955-41 | MANUAL, INSTRUCTION (ITALIAN) (NS76H:AE1) | |
| | 2-666-955-51 | MANUAL, INSTRUCTION (SPANISH) (NS76H:AE2) | |
| | 2-666-955-61 | MANUAL, INSTRUCTION (PORTUGUESE) (NS76H:AE2) | |
| | 2-666-955-71 | MANUAL, INSTRUCTION (GREEK) (NS76H:AE2) | |
| | 2-666-956-12 | MANUAL, INSTRUCTION (ENGLISH) (NS76H:UK) | |
| | 2-666-956-21 | MANUAL, INSTRUCTION (DANISH) (NS76H:AE3) | |
| | 2-666-956-31 | MANUAL, INSTRUCTION (FINNISH) (NS76H:AE3) | |
| | 2-666-956-41 | MANUAL, INSTRUCTION (SWEEDISH) (NS76H:AE3) | |
| | 2-666-956-51 | MANUAL, INSTRUCTION (POLISH) (NS76H:AE3) | |
| | 2-686-160-11 | MANUAL, INSTRUCTION(ENGLISH) (NS71HP) | |
| | 2-666-956-61 | MANUAL, INSTRUCTION (RUSSIAN) (NS76H:RUS) | |
| | 1-479-179-11 | REMOTE COMMANDER (RMT-D175A) (NS71HP/NS75H/NS76H:E, KR) | |
| | 1-479-179-21 | REMOTE COMMANDER(RMT-D175P) (NS76H:SP,AEP,UK,RUS) | |

△ 1-468-974-11 POWER BLOCK (SRV1838UC)
(NS71HP/NS75H)

△ 1-468-973-11 POWER BLOCK (SRV1839WW)
(NS76H)

Note :
The components identified by mark △ or dotted line with mark △ are critical for safety. Replace only with part number specified.

