

Descriptions

The DW8501 is an instant On/Off LED driver for high power LED applications. At DW8501 output stage, one regulated current port is designed to provide a uniform and constant current sink for driving LEDs within a large range of V_F variations. DW8501 easily provides users a consistent current source. User may adjust the output current from up to 1.5A through an external resistor, R_S , which gives users flexibility in controlling the light intensity of LEDs. In addition, users can precisely adjust LED brightness from 0% to 100% via output enable (EN) with Pulse Width Modulation. DW8501 also guarantees that LEDs can be cascaded to maximum 40V at the output port.

Features

- Constant output current invariant to supply and load voltage change
- 5V to 40V supply voltage
- Up to 1.5A adjustable regulated output current
- Built-in thermal derating circuit
- Available PWM dimming control
- Output current adjusted through an external resistor
- TO-252, SOT-223 Package

Applications

- LED light bulbs
- Signage and decorative LED lighting
- General lighting of flat panel displays
- RGB backlighting LED driver
- Current stabilizer with DC/DC or AC/DC
- Automotive lighting
- General purpose constant current source

Typical Application Circuit

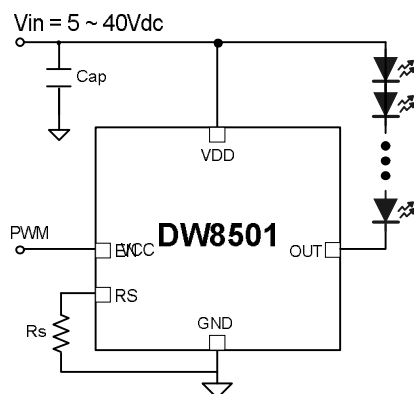

Ordering Information

Device	Marking	Package	Operating Temp
DW8501-TO252	DW8501	TO-252	-35°C ~ +85°C
DW8501-SOT223	DW8501	SOT-223	-35°C ~ +85°C

Package Information



Package	Size
TO-252-5L	6.5x5.5x2.3(mm)
SOT-223-5L	6.5x3.5x1.8(mm)

Pin Connection

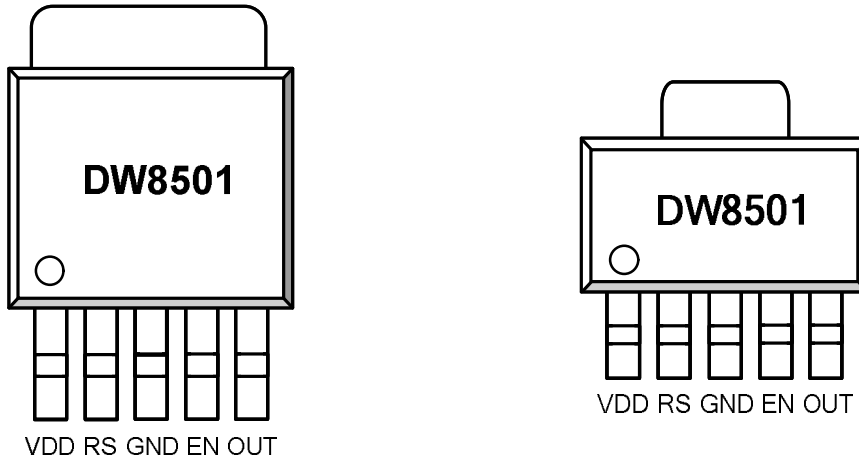

Pin Description

Pin	Name	Description
1	VDD	Supply voltage input
2	RS	Output current set input. Connect a resistor from RS to GND to set the LED bias current
3	GND	Ground
4	EN	Output stage enable control pin. High enable the OUT pin. Dimming control is possible by PWM(Pulse width modulation). Typically, It operates under 30kHz.
5	OUT	Output pin. Sink current is decided by the current on R_{SET} connected to RS
6	HS	Heat sink, normally connected GND

Absolute Maximum Ratings

Characteristics		Symbol	Value	Unit
Supply voltage		V_{DD}	41	V
Output voltage		V_{OUT}	23	V
Enable voltage		V_{EN}	41	V
Reference voltage		V_{RS}	5	V
Package thermal resistance	TO-252-5L	θ_{JA}	38.59	$^{\circ}\text{C}/\text{W}$
	SOT-223-5L	θ_{JA}	80	$^{\circ}\text{C}/\text{W}$
Operating temperature		T_{OPR}	-35~+85	$^{\circ}\text{C}$
Storage Temperature		T_{STG}	-55~+150	$^{\circ}\text{C}$

Note 1. θ_{ja} is measured in the convection at $T_a=30^{\circ}\text{C}$ on a high effective thermal conductivity test board(4 Layers, 2S2P) of JEDEC 51-7 thermal measurement standard.
2. PCB dimension is 100x100x1.6mm and 4 layers.

Recommended Operation Conditions

Characteristics	Symbol	Min.	Typ.	Max.	Unit
Supply voltage	V_{DD}	5	-	40	V
Enable voltage	V_{EN}	-	-	40	V
Output sink current	I_{OUT}	-	-	1.5	A

Electrical Characteristics

$V_{DD} = 24V$, $T_a = -35^{\circ}C \sim +85^{\circ}C$, unless otherwise specified. Typical values are at $T_A = +25^{\circ}C$

Characteristics	Symbol	Conditions	Min.	Typ.	Max.	Unit
Input supply voltage	V_{DD}		5	-	40	V
Output linearity voltage	V_{OUT_LINE}	$V_{DD}=24V$, $I_{SET}=300mA$,	-	-	3	V
Output current	I_{OUT}		-	-	1.5	A
Quiescent Current	I_{Q_ON}	EN = 24V	0.8	1	1.5	mA
	I_{Q_OFF}	EN = 0V	85	120	250	uA
EN input leakage current	I_{EN_LIK}		30	45	60	uA
Input high voltage	V_{IH}		2	-	-	V
Input low voltage	V_{IL}		-	-	0.8	V
LED output drop-out voltage	V_{DROP}	$V_{DD}=40V$, $I_{SET}=300mA$	-	270	-	mV
Thermal derating	T_D		-	140	-	$^{\circ}C$
Thermal derating hysteresis	T_{DHYS}		-	15	-	$^{\circ}C$
Rset Voltage	V_{SET}		0.59	0.61	0.63	V
Output current	I_{OUT}	$2K\Omega$	295	305	315	mA

Note : Output dropout voltage : $90\% \times I_{OUT}$

Block Diagram

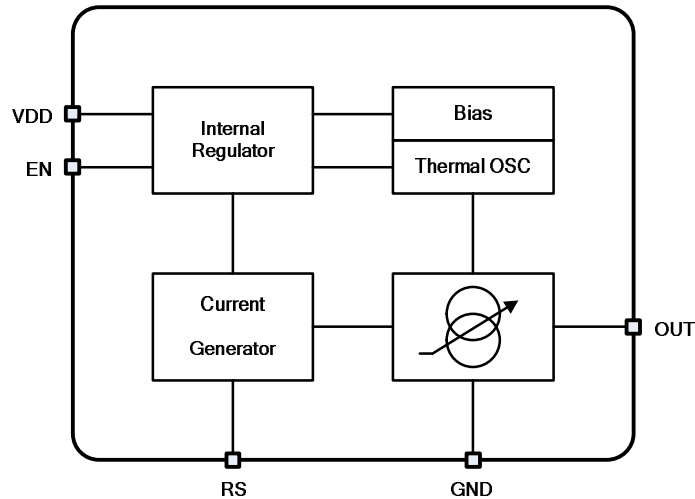

Application notice

Setting Output Current

$$I_{out} [mA] = (610[mV]/R_{set}[ohm]) \times 1000$$

Rset(kΩ)	Iout(mA)
4	152
2	305
1.22	500
1.02	598
0.76	802
0.68	897
0.61	1000

Powersequence

There is an electrostatic diode between VDD and EN.
When dimming control, It must input EN signal after inputs VDD. ($t \geq 1ms$)
If not use Dimming control, EN connect to VDD.

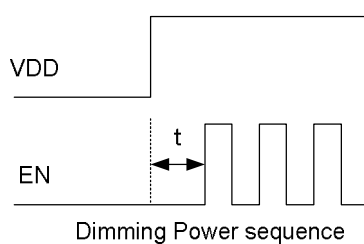

Electrical Characteristics Curves

$V_{DD} = 12V, V_{OUT} = 2V, T_a = -35^{\circ}C \sim +85^{\circ}C$, unless otherwise specified. Typical values are at $T_A = +25^{\circ}C$

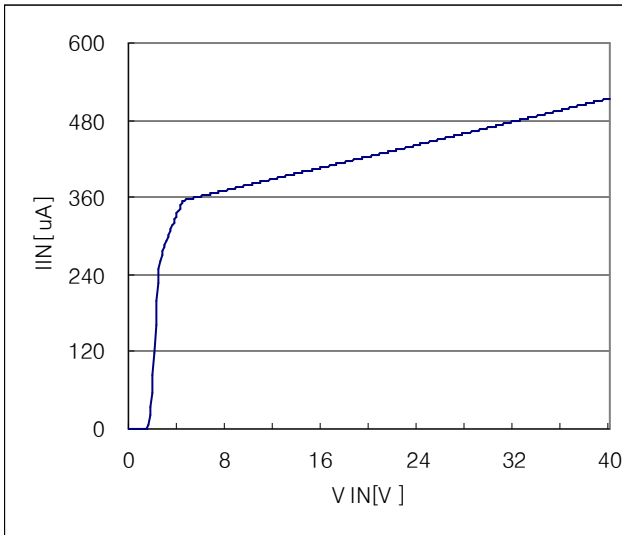

Quiescent vs. VDD

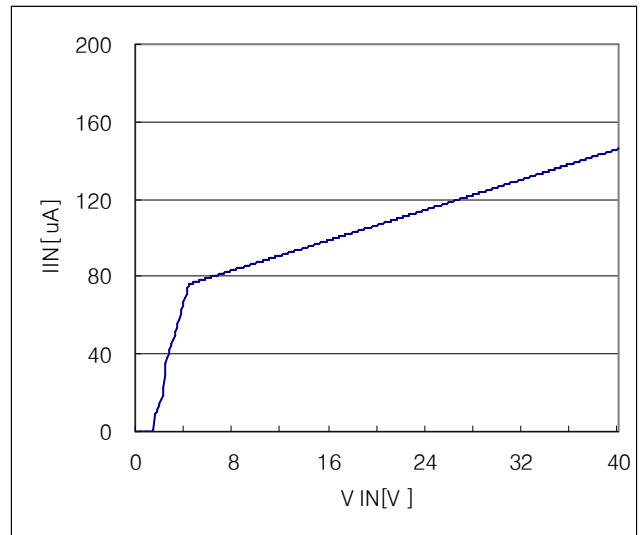

Ishutdown vs. VDD

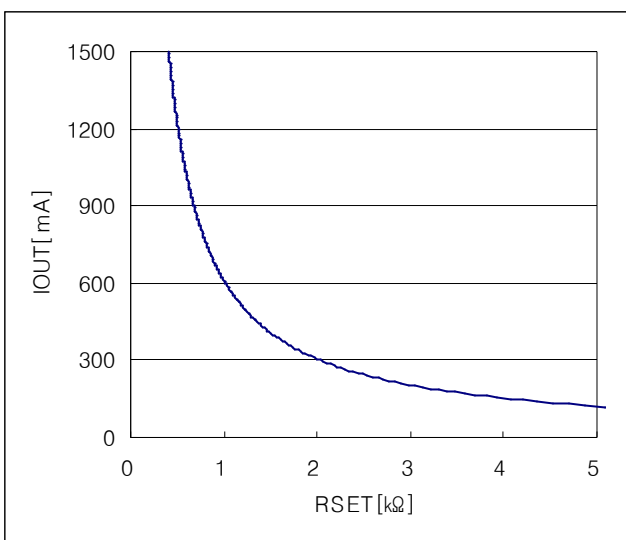

IOUT vs. Rset

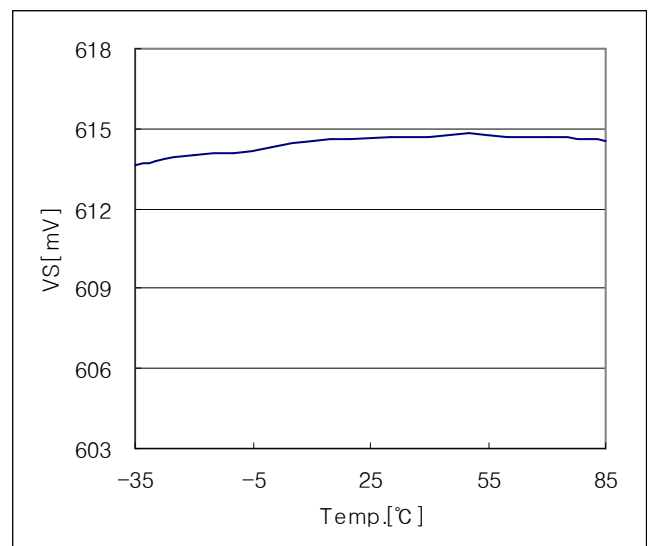

Vreference vs. Temperature

Electrical Characteristics Curves (continued)

$V_{DD} = 12V, V_{OUT} = 2V, T_a = -35^{\circ}C \sim +85^{\circ}C$, unless otherwise specified. Typical values are at $T_A = +25^{\circ}C$

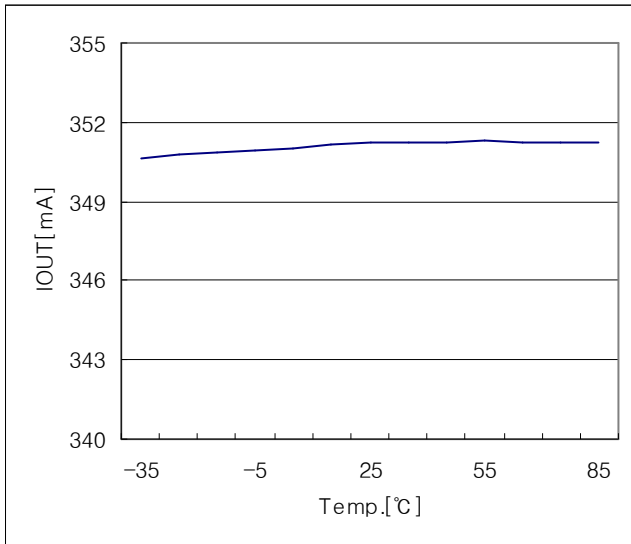

IOUT vs. Temperature

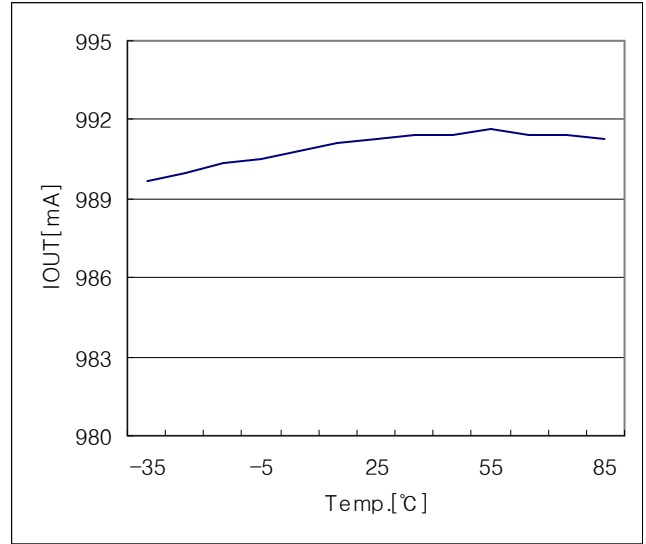

IOUT vs. Temperature

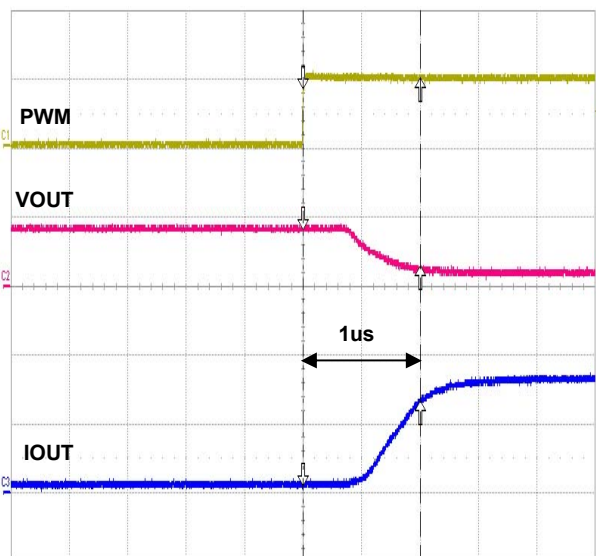

PWM Rising Time

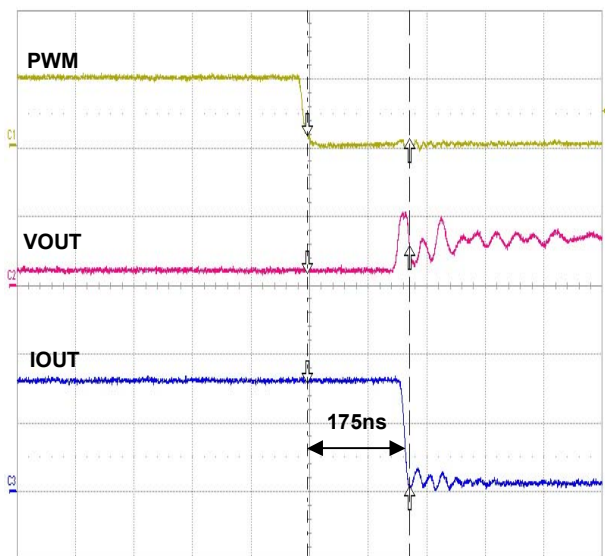

PWM Falling Time

Typical Applications

※ LED VF = 3.3V, IF = 20mA

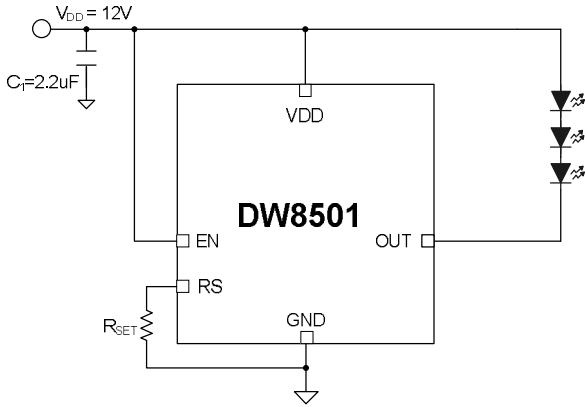

Figure 1. VDD=12V

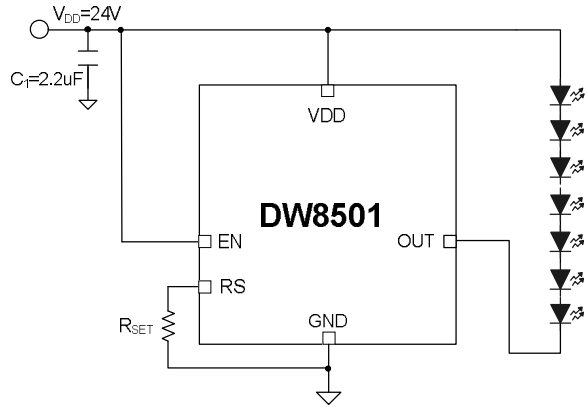

Figure 2. VDD=24V

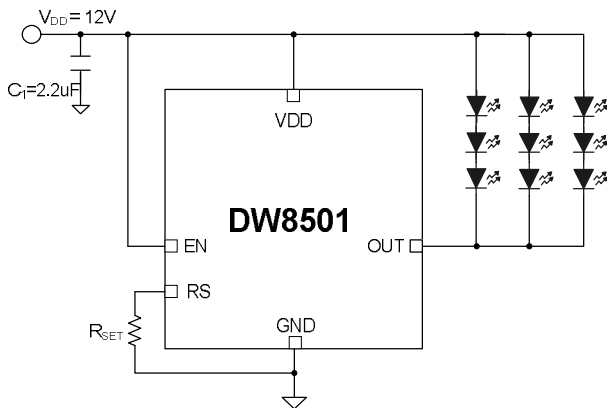

Figure 3. PWM Dimming Typical Application

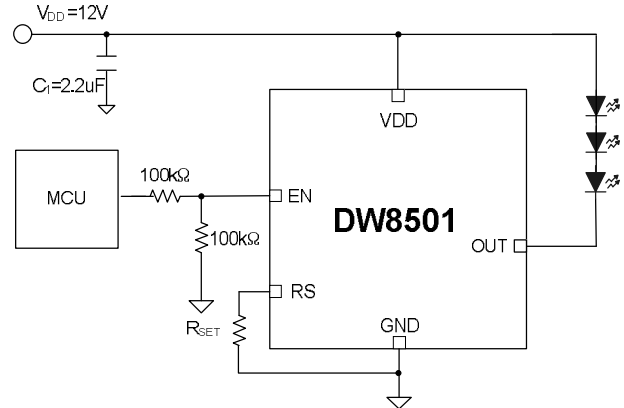

Figure 4. VDD=12V, 9 LED

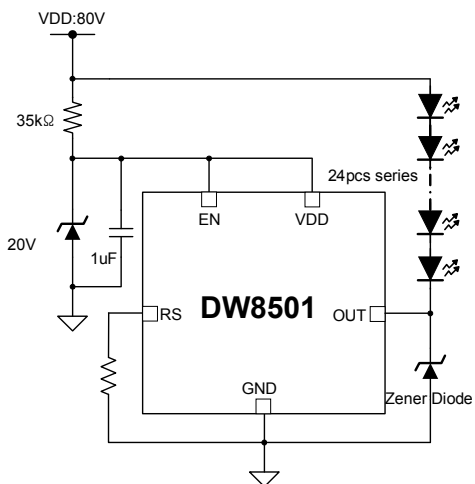
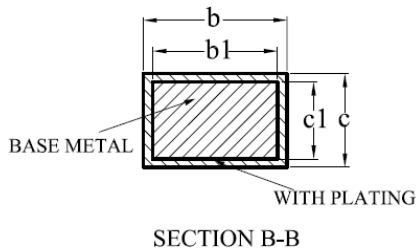
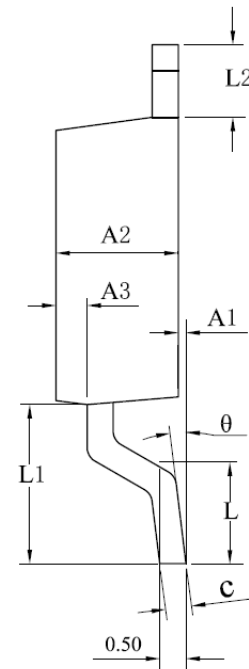
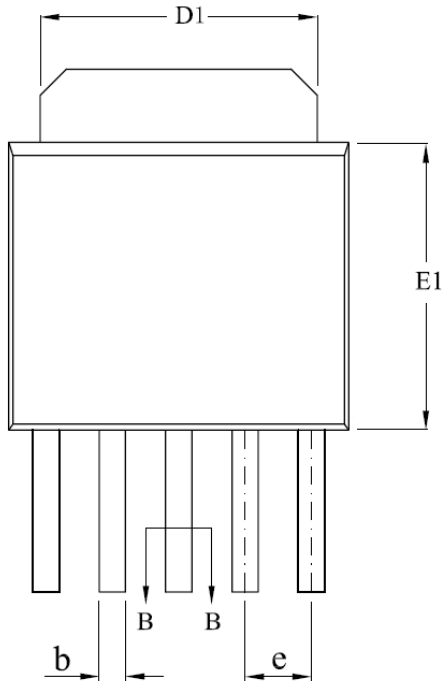

Figure 5. High Voltage Application (VDD=80V)

Package Dimension (TO-252-5L 6.5 x 10 x 2.3)



SYMBOL	MILLIMETER		
	MIN	NOM	MAX
A1	0.05	0.15	0.25
A2	2.10	2.30	2.50
A3	0.50	0.60	0.70
b	0.46	—	0.60
b1	0.45	0.50	0.55
c	0.49	—	0.56
c1	0.48	0.50	0.52
D	6.30	6.50	6.70
D1	5.30REF		
E1	5.30	5.50	5.70
e	1.27BSC		
L	1.40	1.50	1.60
L1	3.00	3.10	3.20
L2	1.40BSC		
θ	0	—	8°

Foot Print

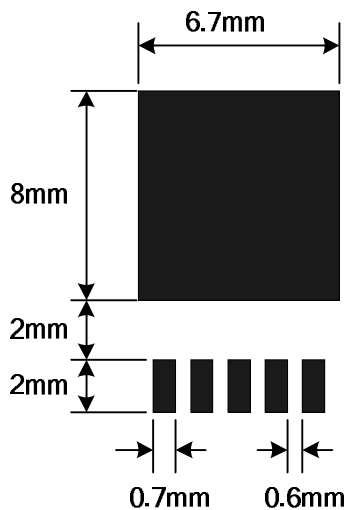

Package Dimension (SOT-223-5L 6.5 x 7 x 1.8)

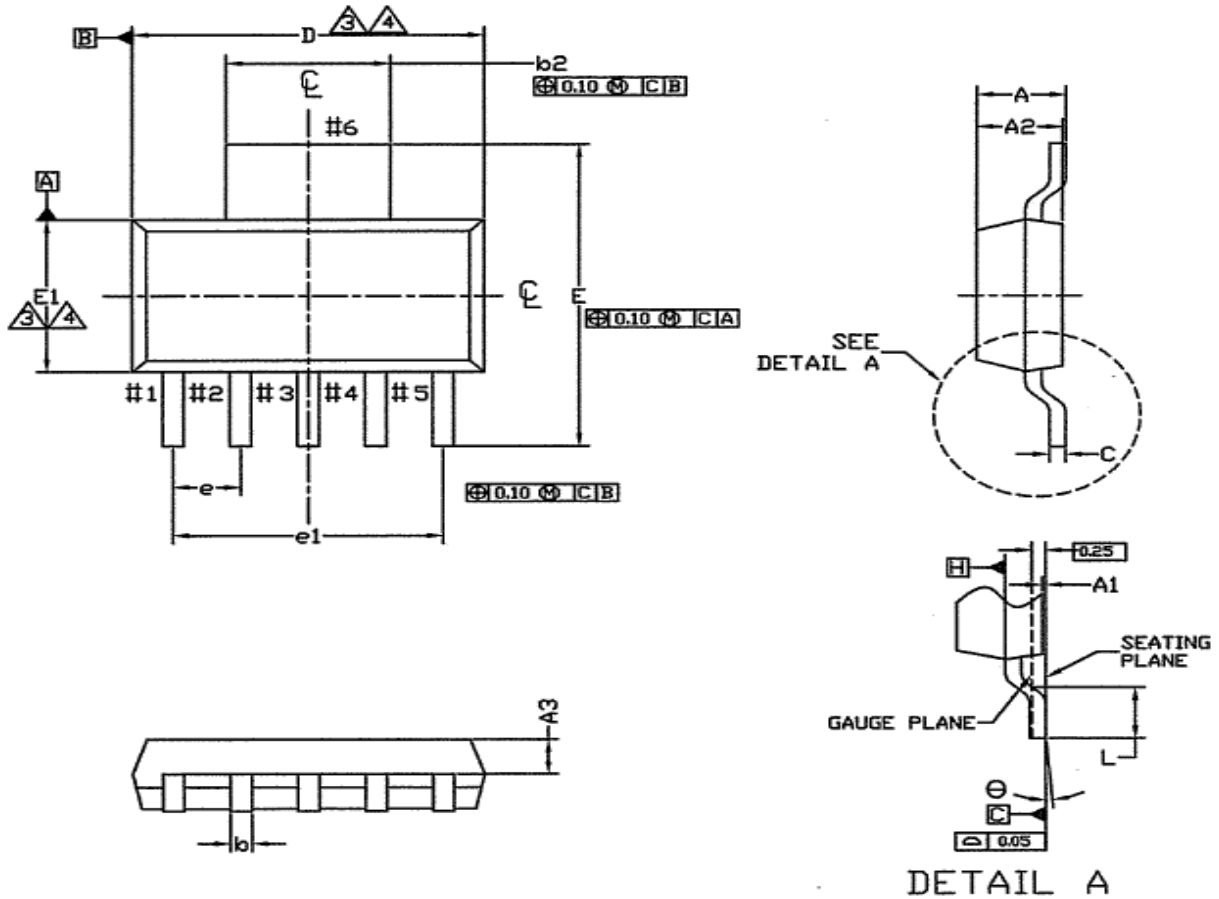

Foot Print

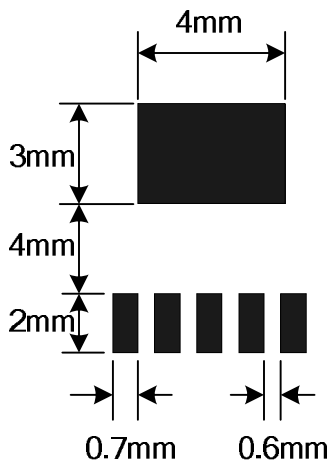

SYMBOL	ALL DIMENSIONS IN MILLIMETERS		
	MINIMUM	NORMAL	MAXIMUM
A	-	-	1.80
A1	0.02	0.06	0.10
A2	1.55	1.60	1.65
A3	0.90 REF.		
b	0.41	0.457	0.51
b2	2.95	3.00	3.05
c	0.24	0.28	0.32
D	6.45	6.50	6.55
E	6.86	7.00	7.26
E1	3.45	3.50	3.55
e	1.27 BSC.		
e1	5.08 BSC.		
L	0.91	-	1.14
θ	0°	4°	8°