



# DX10N60R/DX10N60F

## N-Channel MOSFET 600V, 10A, 0.7Ω

### General Description

These N-channel MOSFET are produced using advanced DeXin's MOSFET Technology, which provides low on- state resistance, rugged avalanche, high switching performance and excellent quality.

These devices are suitable device for SMPS, high Speed switching and general purpose applications.

### Features

- $V_{DS} = 600V$
- $V_{DS} = 660V$  @  $T_{jmax}$
- $I_D = 10A$  @  $V_{GS} = 10V$
- $R_{DS(ON)} \leq 0.7\Omega$  @  $V_{GS} = 10V$

### Applications

- Power Supply
- PFC
- High Current, High Speed Switching

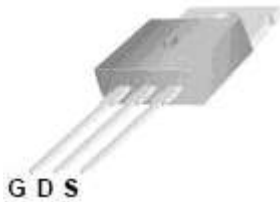

TO-220  
DX F Series



TO-220F  
DX Series

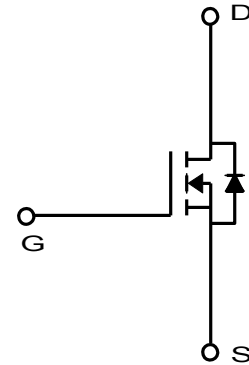

### Absolute Maximum Ratings ( $T_a = 25^\circ C$ )

Characteristics		Symbol	MDP10N60G	MDF10N60G	Unit
Drain-Source Voltage		$V_{DSS}$	600		V
Drain-Source Voltage @ $T_{jmax}$		$V_{DSS} @ T_{jmax}$	660		V
Gate-Source Voltage		$V_{GSS}$	±30		V
Continuous Drain Current	$T_c=25^\circ C$	$I_D$	10	10*	A
	$T_c=100^\circ C$		6.3	6.3*	A
Pulsed Drain Current <sup>(1)</sup>		$I_{DM}$	40	40*	A
Power Dissipation	$T_c=25^\circ C$	$P_D$	156	48	W W/°C
	Derate above 25 °C		1.25	0.38	
Repetitive Avalanche Energy <sup>(1)</sup>		$E_{AR}$	15.6		mJ
Peak Diode Recovery $dv/dt$ <sup>(3)</sup>		$dv/dt$	4.5		V/ns
Single Pulse Avalanche Energy <sup>(4)</sup>		$E_{AS}$	520		mJ
Junction and Storage Temperature Range		$T_J, T_{stg}$	-55~150		°C

\*  $I_D$  limited by maximum junction temperature

### Thermal Characteristics

Characteristics	Symbol	MDP10N60G	MDF10N60G	Unit
Thermal Resistance, Junction-to-Ambient <sup>(1)</sup>	$R_{\theta JA}$	62.5	62.5	°C/W
Thermal Resistance, Junction-to-Case <sup>(1)</sup>	$R_{\theta JC}$	0.8	2.6	

## Ordering Information

Part Number	Temp. Range	Package	Packing	RoHS Status
DX10N60R	-55~150°C	TO-220	Tube	Halogen Free
DX10N60F	-55~150°C	TO-220F	Tube	Halogen Free

## Electrical Characteristics (Ta =25°C)

Characteristics	Symbol	Test Condition	Min	Typ	Max	Unit
<b>Static Characteristics</b>						
Drain-Source Breakdown Voltage	$BV_{DSS}$	$I_D = 250\mu A, V_{GS} = 0V$	600	-	-	V
Gate Threshold Voltage	$V_{GS(th)}$	$V_{DS} = V_{GS}, I_D = 250\mu A$	3.0	-	5.0	V
Drain Cut-Off Current	$I_{DSS}$	$V_{DS} = 600V, V_{GS} = 0V$	-	-	1	$\mu A$
Gate Leakage Current	$I_{GSS}$	$V_{GS} = \pm 30V, V_{DS} = 0V$	-	-	100	nA
Drain-Source ON Resistance	$R_{DS(ON)}$	$V_{GS} = 10V, I_D = 5.0A$	-	0.58	0.7	$\Omega$
Forward Transconductance	$g_{fs}$	$V_{DS} = 30V, I_D = 5.0A$	-	9	-	S
<b>Dynamic Characteristics</b>						
Total Gate Charge	$Q_g$	$V_{DS} = 480V, I_D = 10A, V_{GS} = 10V^{(3)}$	-	32	-	nC
Gate-Source Charge	$Q_{gs}$		-	8.7	-	
Gate-Drain Charge	$Q_{gd}$		-	12.2	-	
Input Capacitance	$C_{iss}$	$V_{DS} = 25V, V_{GS} = 0V, f = 1.0MHz$	-	1360	-	pF
Reverse Transfer Capacitance	$C_{rss}$		-	7.7	-	
Output Capacitance	$C_{oss}$		-	151	-	
Turn-On Delay Time	$t_{d(on)}$	$V_{GS} = 10V, V_{DS} = 300V, I_D = 10A, R_G = 25\Omega^{(3)}$	-	53	-	ns
Rise Time	$t_r$		-	38	-	
Turn-Off Delay Time	$t_{d(off)}$		-	116	-	
Fall Time	$t_f$		-	32	-	
<b>Drain-Source Body Diode Characteristics</b>						
Maximum Continuous Drain to Source Diode Forward Current	$I_S$		-	10	-	A
Source-Drain Diode Forward Voltage	$V_{SD}$	$I_S = 10A, V_{GS} = 0V$	-		1.4	V
Body Diode Reverse Recovery Time	$t_{rr}$	$I_F = 10A, di/dt = 100A/\mu s^{(3)}$	-	340	-	ns
Body Diode Reverse Recovery Charge	$Q_{rr}$		-	3.3	-	$\mu C$

Note :

1. Pulse width is based on  $R_{\theta JC}$  &  $R_{\theta JA}$  and the maximum allowed junction temperature of 150°C.
2. Pulse test: pulse width  $\leq 300\mu s$ , duty cycle  $\leq 2\%$ , pulse width limited by junction temperature  $T_{J(MAX)} = 150^\circ C$ .
3.  $I_{SD} \leq 10A$ ,  $di/dt \leq 200A/\mu s$ ,  $V_{DD} = 50V$ ,  $R_G = 25\Omega$ , Starting  $T_J = 25^\circ C$
4.  $L = 9.6mH$ ,  $I_{AS} = 10.0A$ ,  $V_{DD} = 50V$ ,  $R_G = 25\Omega$ , Starting  $T_J = 25^\circ C$ ,

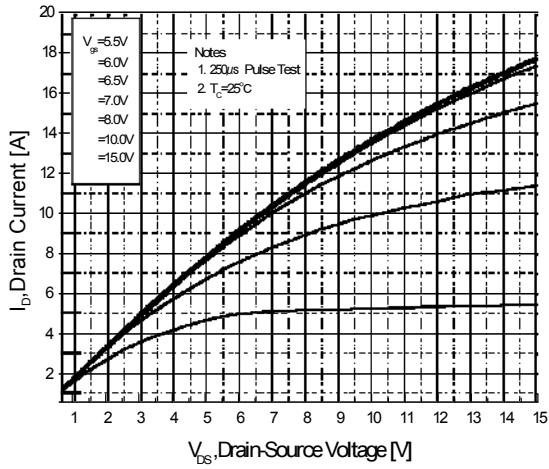

Fig.1 On-Region Characteristics

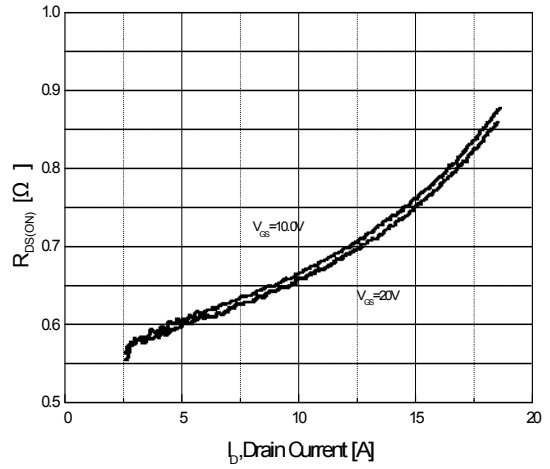

Fig.2 On-Resistance Variation with Drain Current and Gate Voltage

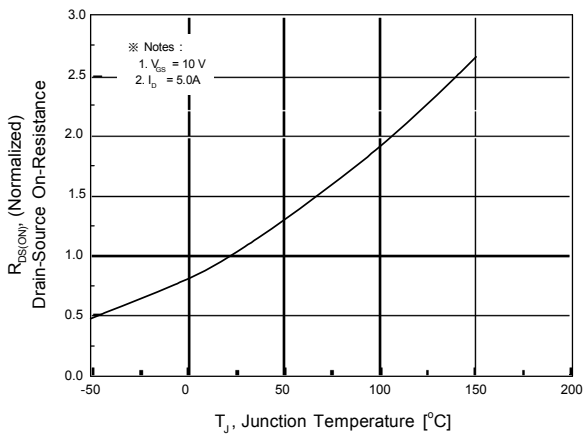

Fig.3 On-Resistance Variation with Temperature

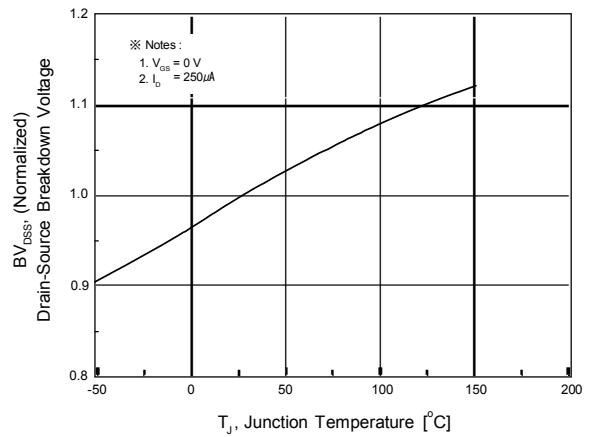

Fig.4 Breakdown Voltage Variation vs. Temperature

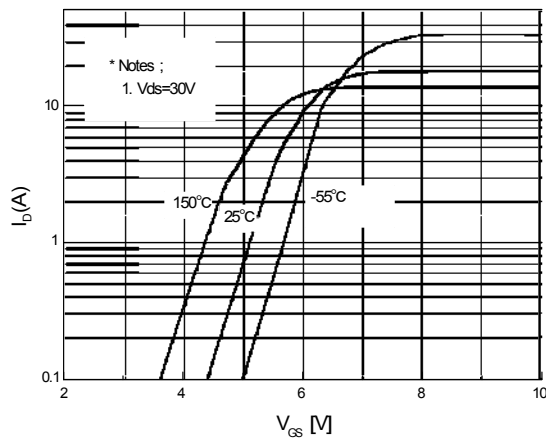

Fig.5 Transfer Characteristics

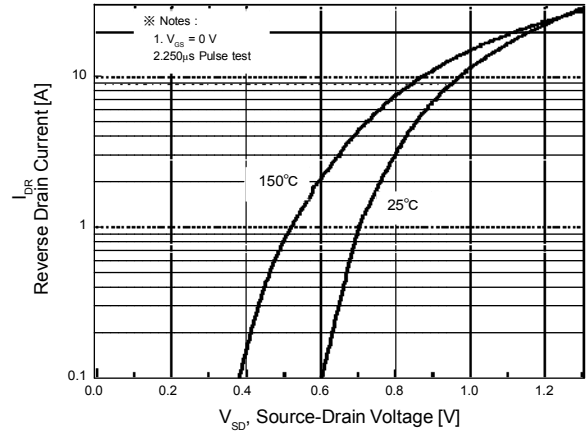

Fig.6 Body Diode Forward Voltage Variation with Source Current and Temperature

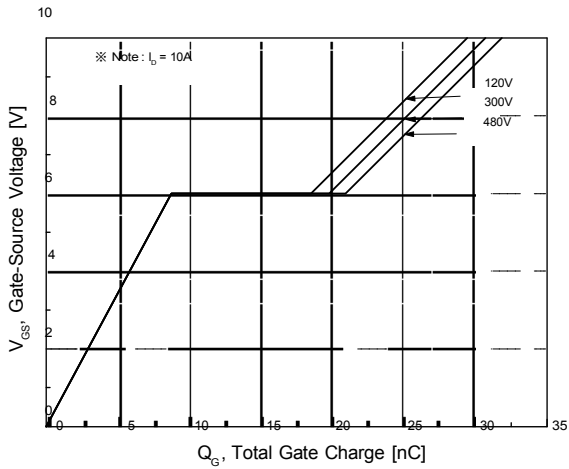

Fig.7 Gate Charge Characteristics

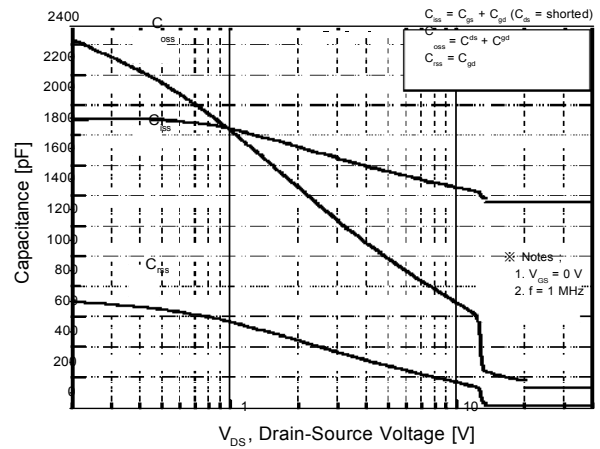

Fig.8 Capacitance Characteristics

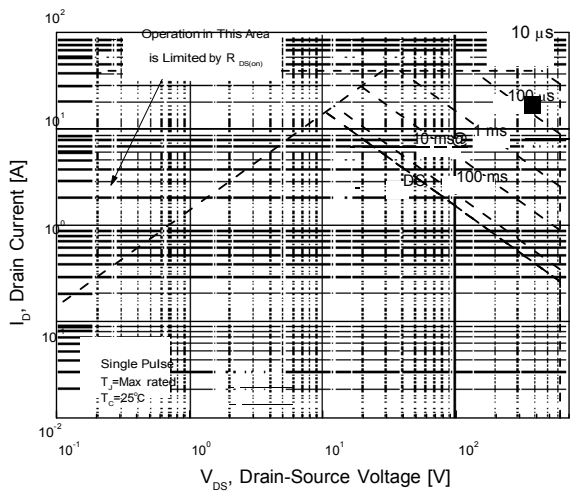

Fig.9 Maximum Safe Operating Area  
DX10N60R(TO-220)

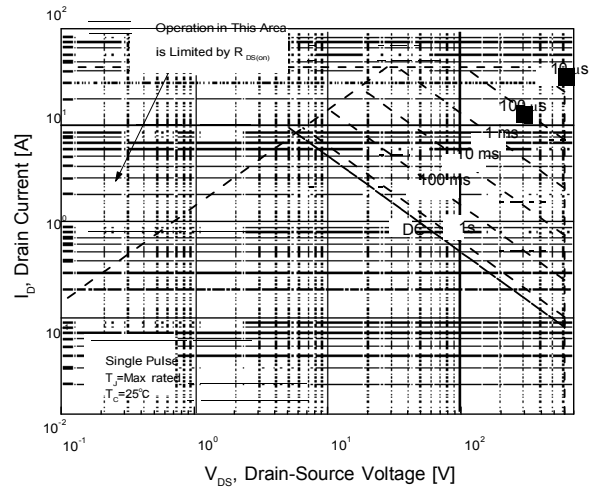

Fig.10 Maximum Safe Operating Area  
DX10N60F(TO-220F)

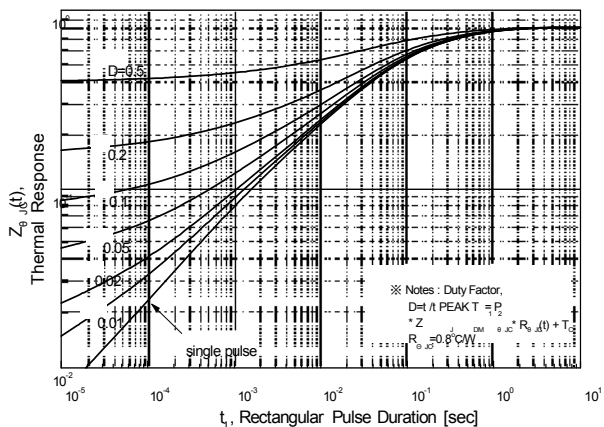

Fig.11 Transient Thermal Response Curve  
DX10N60R(TO-220)

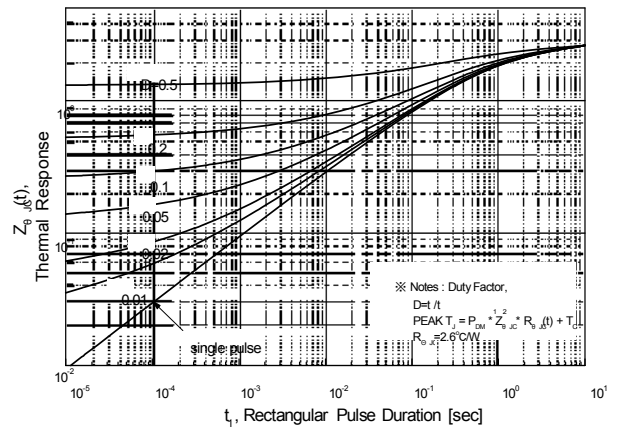

Fig.12 Transient Thermal Response Curve  
DX10N60F(TO-220F)

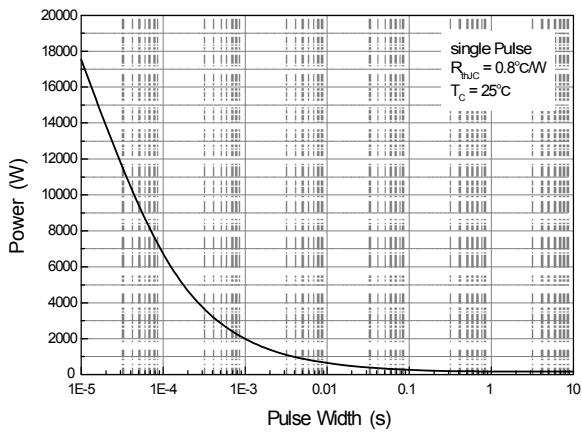

Fig.13 Single Pulse Maximum Power Dissipation DX10N60R(TO-220)

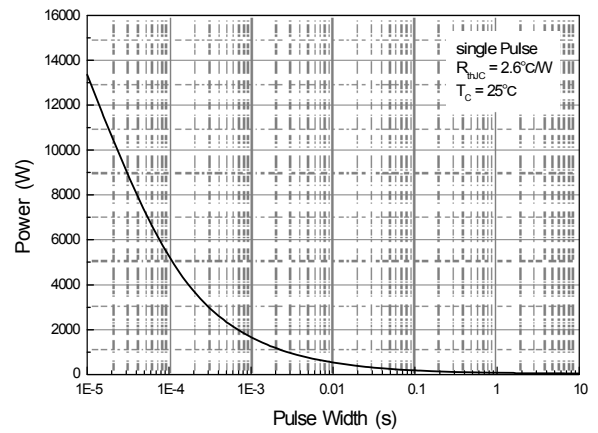

Fig.14 Single Pulse Maximum Power Dissipation DX10N60F(TO-220F)

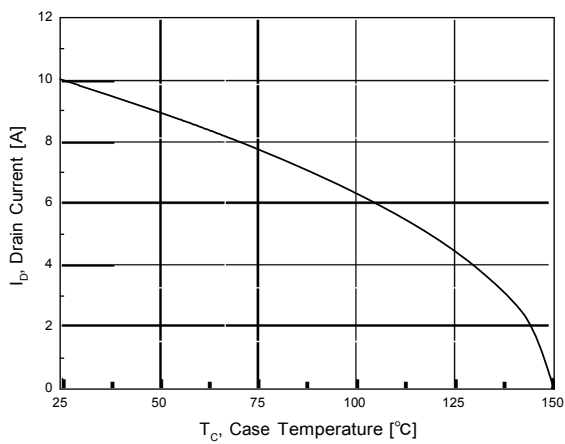
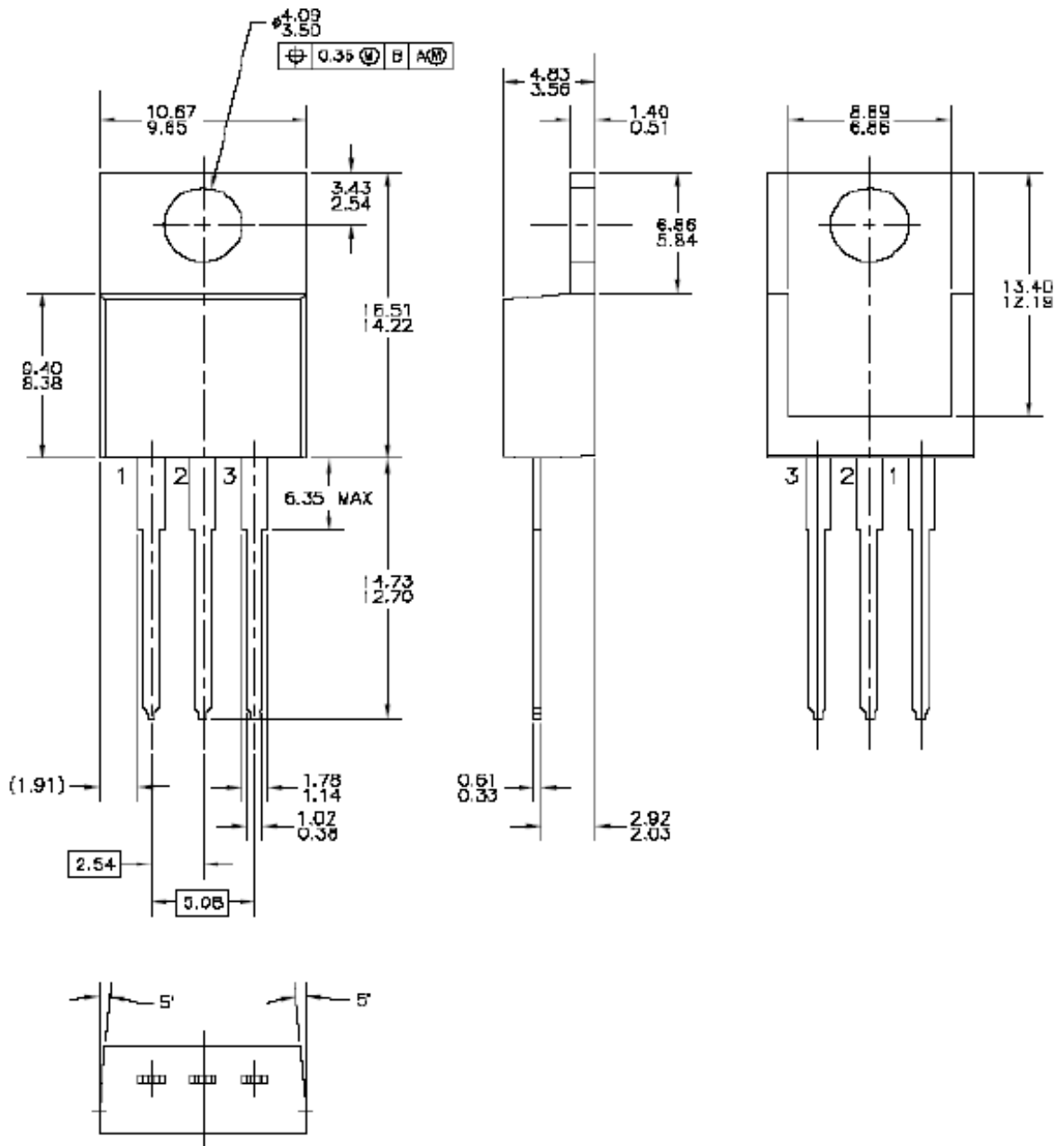

Fig.15 Maximum Drain Current vs. Case Temperature

Physical Dimensions

TO-220



## Physical Dimensions

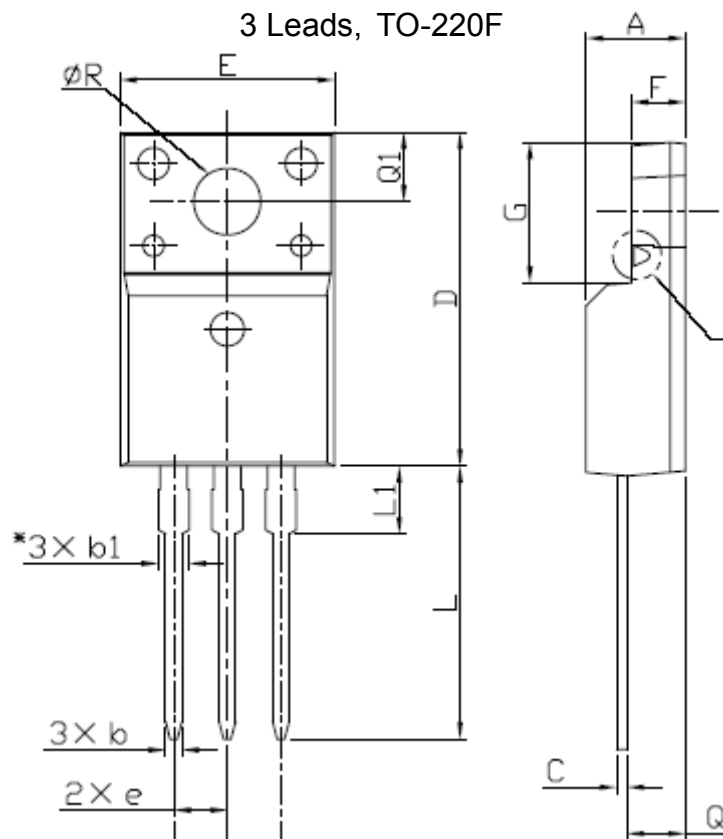

Dimensions are in millimeters unless otherwise specified

Symbol	Min	Nom	Max
A	4.50		4.93
b	0.63		0.91
b1	1.15		1.47
C	0.33		0.63
D	15.47		16.13
E	9.60		10.71
e		2.54	
F	2.34		2.84
G	6.48		6.90
L	12.24		13.72
L1	2.79		3.67
Q	2.52		2.96
Q1	3.10		3.50
ϕ R	3.00		3.55

**DISCLAIMER:**

The Products are not designed for use in hostile environments, including, without limitation, aircraft, nuclear power generation, medical appliances, and devices or systems in which malfunction of any Product can reasonably be expected to result in a personal injury. Seller's customers using or selling Seller's products for use in such applications do so at their own risk and agree to fully defend and indemnify Seller.