

DYP Ultrasonic Sensor

DYP-ME007Y-PWM module provides ultrasonic 30cm-3m of non-contact distance measurement function, range sensor in the sensor output corresponding to the objects in the high pulse width signal. Right picture shows the DYP-ME007Y-PWM appearance.

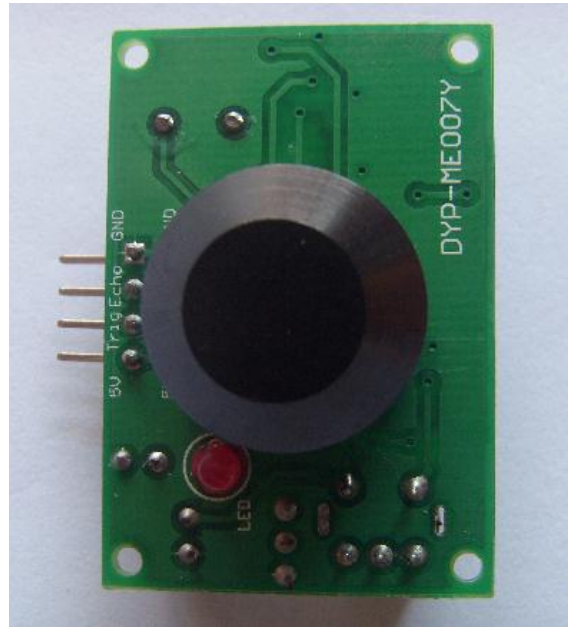

Features

- Detecting range: 30cm-3m
- Best in 30 degree angle
- Electronic brick compatible interface
- 5VDC power supply
- Breadboard friendly
- Dual transducer

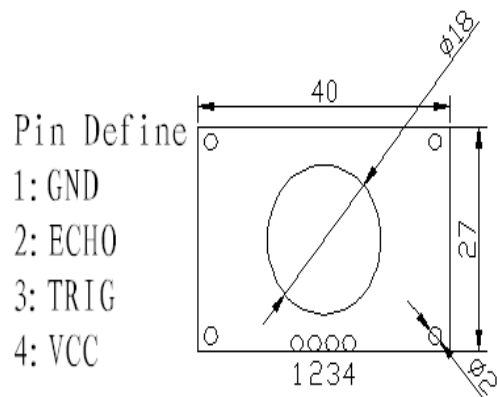

Specifications

Supply voltage	5 v
Global Current Consumption	15 mA
Ultrasonic Frequency	40k Hz
Maximal Range	350 cm
Minimal Range	30 cm
Resolution	1 cm
Trigger Pulse Width	10 μ s
Outline Dimension	40x27x15 mm

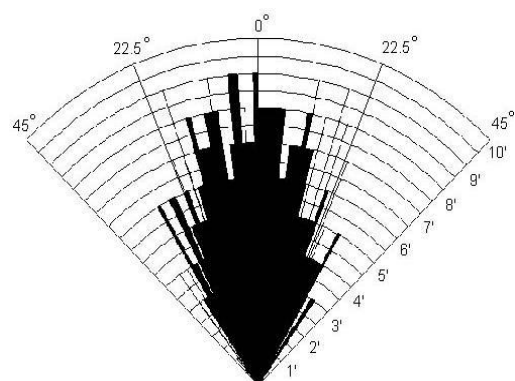

*Practical test of performance,
Best in 30 degree*

Sequence chart

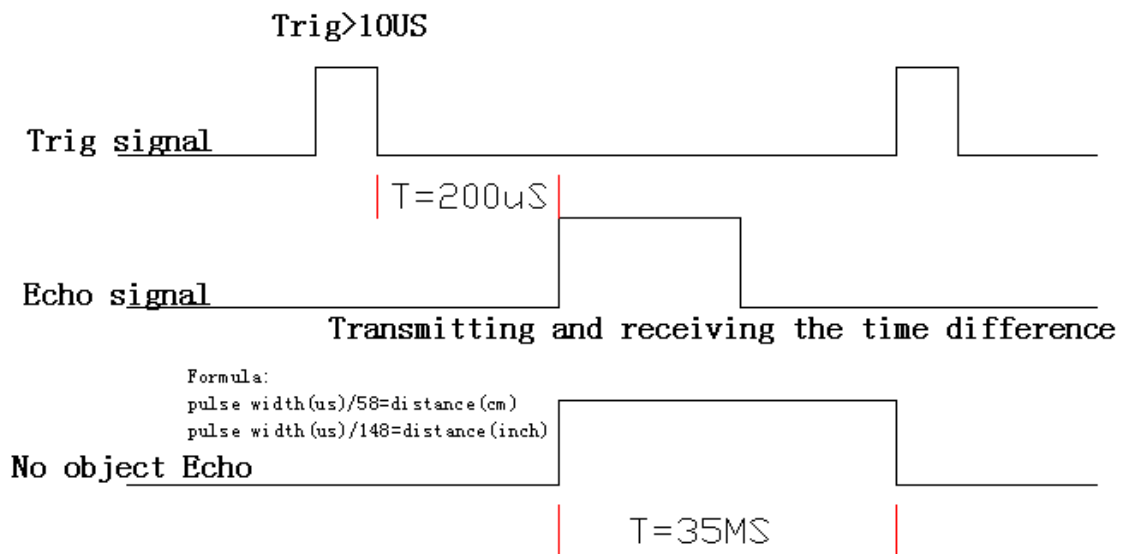

Description:

After power on, the module waiting for the trigger signal. Triggered automatically issued within 8 40kHz cycle level, and to detect the long echo time, and through the corresponding timer output level TTL level PWM pulse width. According to the object at different distances, a corresponding proportion of the output pulse width. MCU can be used to determine the timing of pulses calculated distance. Formula: $\mu\text{S}/5.8 = \text{mm}$, or $\mu\text{S}/148 = \text{inches}$. If the object is not detected, the module output pin pin will output a constant pulse width of about 35MS.

Note: The module detects a minimum distance of 30cm, 30cm inside the object, the signal will be inaccurate.