

ALTERNATOR DIODE FOR AUTOMOTIVE APPLICATION.

FEATURES

- Average Forward Current : $I_O=30A$.
- Zener Voltage : 23V(Typ.)

POLARITY

E30A23VPS E30A23VPR
(+ Type) (- Type)

MAXIMUM RATING (Ta=25)

CHARACTERISTIC	SYMBOL	RATING	UNIT
Average Forward Current	$I_{F(AV)}$	30	A
Peak 1 Cycle Surge Current	$I_{F(1)}$	300(50Hz)	A
Repetitive Peak Reverse Surge Current	I_{RSM}	20	A
Transient Peak Reverse Voltage	V_{RSM}	17	V
Peak Reverse Voltage	V_{RM}	17	V
Junction Temperature	T_j	-40 ~ 200	°C
Storage Temperature Range	T_{stg}	-40 ~ 200	°C

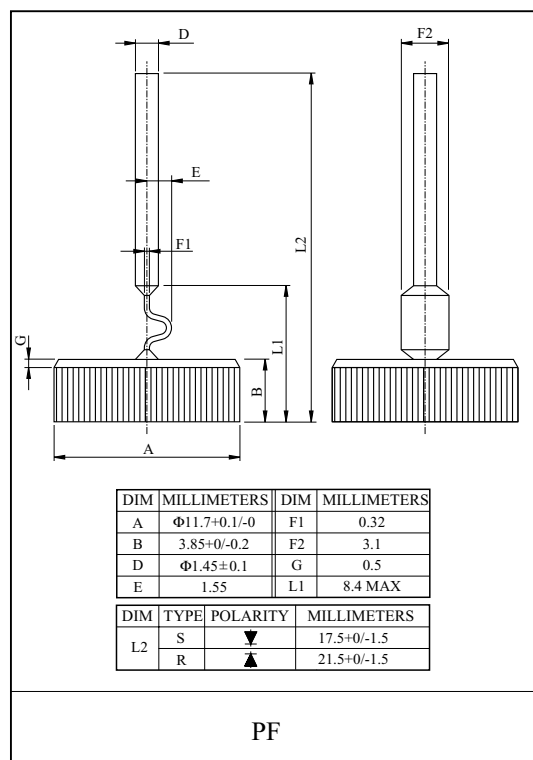

ELECTRICAL CHARACTERISTICS (Ta=25)

CHARACTERISTIC	SYMBOL	TEST CONDITION	MIN.	TYP.	MAX.	UNIT
Peak Forward Voltage	V_{FM}	$I_{FM}=100A$	-	-	1.17	V
Zener Voltage	V_Z	$I_Z=10mA$	21	23	25	V
Repetitive Peak Reverse Current	I_{RRM}	$V_R=V_{RM}$	-	-	10	μA
Transient Thermal Resistance	V_F	$I_{FM}=100A$	-	-	140	mV
Reverse Leakage Current Under High Temperature	HIR	$T_a=150$, $V_R=V_{RM}$	-	-	2.5	mA
Temperature Resistance	R_{th}	DC total junction to case	-	-	1.0	/W