

ALTERNATOR DIODE FOR AUTOMOTIVE APPLICATION.

FEATURES

- Average Forward Current : $I_O=30A$.
- Reverse Voltage : 200V(Min)

POLARITY

E30A2CDS E30A2CDR
(+ Type) (- Type)

MAXIMUM RATING (Ta=25 °C)

CHARACTERISTIC	SYMBOL	RATING	UNIT
Repetitive Peak Reverse Voltage	V_{RRM}	200	V
Average Forward Current	$I_{F(AV)}$	30	A
Peak 1 Cycle Surge Current	I_{FSM}	300 (10ms Condition)	A
Junction Temperature	T_j	-40 ~ 200	°C
Storage Temperature Range	T_{stg}	-40 ~ 200	°C

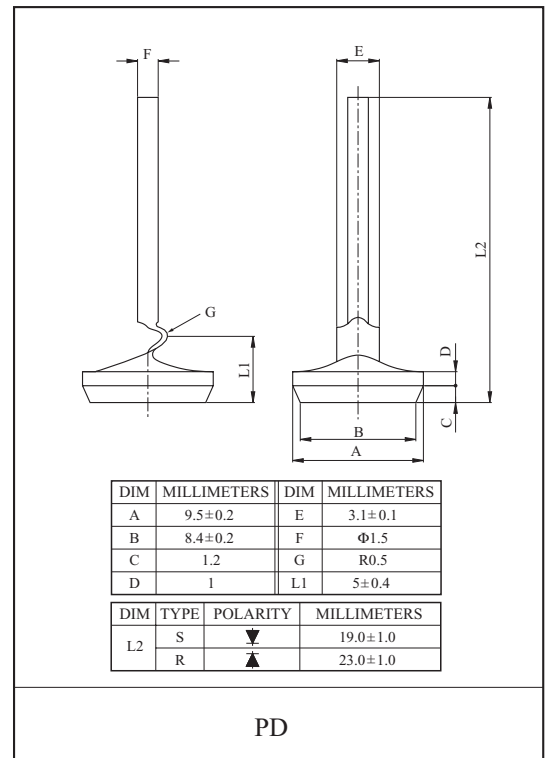

ELECTRICAL CHARACTERISTICS (Ta=25 °C)

CHARACTERISTIC	SYMBOL	TEST CONDITION	MIN.	TYP.	MAX.	UNIT
Peak Forward Voltage	V_{FM}	$I_{FM}=100A$	-	-	1.20	V
Reverse Voltage	V_{RM}	$I_R=5mA$	200	-	-	V
Repetitive Peak Reverse Current	I_{RRM}	$V_R=200V$	-	-	50	μA
Reverse Recovery Time	t_{rr}	$I_F=-I_R 100mA$	-	-	15	μS
Reverse Leakage Current Under High Temperature	H_{IR}	Ta=150 °C, $V_R=V_{RM}$	-	-	2.5	mA
Temperature Resistance	R_{th}	Junction to case	-	1.0	-	°C/W