

ALTERNATOR DIODE FOR AUTOMOTIVE APPLICATION.

FEATURES

- Average Forward Current : $I_O=35A$.
- Repetitive Peak Reverse Voltage : $V_{RRM}=200V$

POLARITY

E35A2CBS E35A2CBR
(+ Type) (- Type)

MAXIMUM RATING (Ta=25 °C)

CHARACTERISTIC	SYMBOL	RATING	UNIT
Average Forward Current	$I_{F(AV)}$	35	A
Peak 1 Cycle Surge Current	I_{FSM}	300 (60Hz)	A
Repetitive Peak Reverse Voltage	V_{RRM}	200	V
Junction Temperature	T_j	-40 ~ 215	°C
Storage Temperature Range	T_{stg}	-40 ~ 215	°C

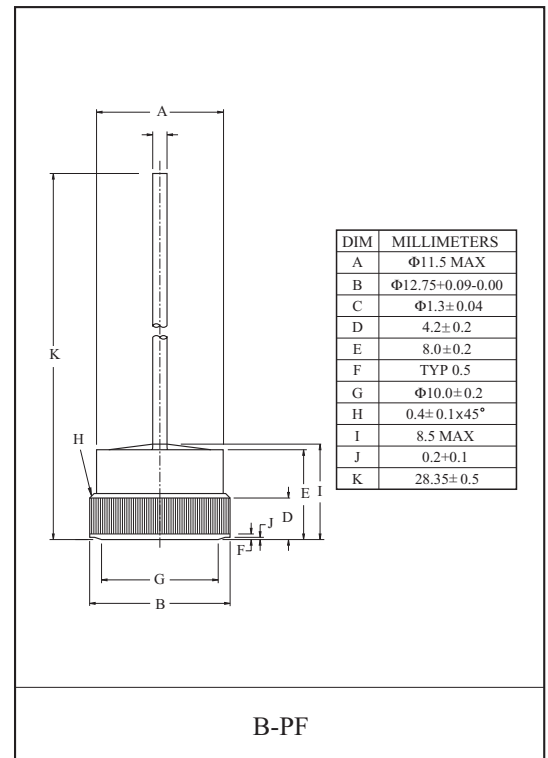

ELECTRICAL CHARACTERISTICS (Ta=25 °C)

CHARACTERISTIC	SYMBOL	TEST CONDITION	MIN.	TYP.	MAX.	UNIT
Forward Voltage	V_F	$I_{FM}=100A$	-	-	1.10	V
Reverse Voltage	V_R	$I_R=5mA$	200	-	-	V
Reverse Current	I_R	$V_R=200V$	-	-	50	μA
Transient Thermal Resistance	ΔV_F	$I_{FM}=100A, I_M=100mA, P_w=100ms$	-	-	100	mV
Reverse Leakage Current Under High Temperature	HI_R	$T_a=150\text{ °C}, V_R=200V$	-	-	2.5	mA
Reverse Recovery Time	t_{rr}	$I_F=0.1A, I_R=0.1A$	-	-	15	μs
Temperature Resistance	R_{th}	DC total Junction to case	-	-	0.8	°C/W