

E5AX Temperature Controllers

with SPI Protocol Communication

System Manual

Produced June 1993

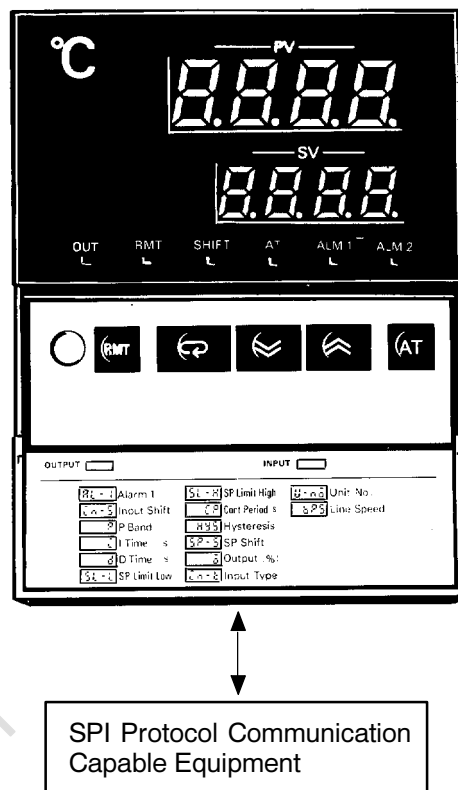

www.datasheet4u.com

www.DataSheet4U.com

Notice:

OMRON products are manufactured for use according to proper procedures by a qualified operator and only for the purposes described in this manual.

The information in this manual should be read completely and be thoroughly understood prior to attempting to operate the E5AX Temperature Controller.

The following conventions are used to indicate and classify warnings in this manual. Always heed the information provided with them.

DANGER! Indicates information that, if not heeded, could result in loss of life or serious injury.

Caution Indicates information that, if not heeded, could result in minor injury or damage to the product.

OMRON Product References

All OMRON product names are capitalized in this manual.

The abbreviation TC means Temperature Controller unless otherwise specified.

Visual Aids

The following headings appear in the left column of the manual to help you locate different types of information.

Note Indicates information of particular interest for efficient and convenient operation of the product.

© OMRON, 1993

All rights reserved. No part of this publication may be reproduced, stored in a retrieval system, or transmitted, in any form, or by any means, mechanical, electronic, photocopying, recording, or otherwise, without the prior written permission of OMRON.

No patent liability is assumed with respect to the use of the information contained herein. Moreover, because OMRON is constantly striving to improve its high-quality products, the information contained in this manual is subject to change without notice. Every precaution has been taken in the preparation of this manual. Nevertheless, OMRON assumes no responsibility for errors or omissions. Neither is any liability assumed for damages resulting from the use of the information contained in this publication.

TABLE OF CONTENTS

SECTION 1

Introduction 1

1-1 Introductory Terms and Definitions 2

1-2 System Configuration 2

1-3 Supported SPI Protocol Software Commands 3

SECTION 2

Components and Switch Settings 5

2-1 Front Panel 6

2-2 Back Panel 7

2-3 Setting the E5AX Internal Switches 9

SECTION 3

Installation 23

3-1 Wiring 24

3-2 Mounting 26

SECTION 4

Operation 31

4-1 Setting the E5AX Controller 32

4-2 Programming the E5AX 33

SECTION 5

Troubleshooting 51

5-1 E5AX Front Panel 52

5-2 Establishing Communication 52

5-3 Software Errors 58

5-4 SPI Protocol Error Byte 58

APPENDICES

A Standard Models 63

B Hardware Specifications 65

C Dimensions 69

D Communication Protocol Specification 71

E Alarm Setting 79

F Communication Flowchart 83

G ASCII List 85

Glossary 87

Index 95

OMRON Sales Offices 101

Revision History 105

About this Manual:

This manual describes the proper operation of the E5AX Temperature Controller with SPI protocol communication.

Section 1 introduces the relationship of the E5AX Temperature Controller to the SPI communication protocol network.

Section 2 provides a general description of the E5AX front and back panels, and internal switch settings.

Section 3 indicates proper wiring and panel mounting methods.

Section 4 describes setting the E5AX for both remote and direct programming.

Section 5 provides a troubleshooting guide.

Appendix A lists the part numbers for all the standard parts.

Appendix B details the hardware specifications.

Appendix C provides the dimensions of the various products.

Appendix D details the communication protocol specifications.

Appendix E explains the relationship of the E5AX to the SPI protocol.

Appendix F describes the tributary communication behavior for polling and selecting.

Appendix G provides an ASCII code list.

SECTION 1

Introduction

1-1	Introductory Terms and Definitions	2
1-2	System Configuration	2
1-3	Supported SPI Protocol Software Commands	3

1-1 Introductory Terms and Definitions

SPI

The Society of the Plastics Industry, Inc., Washington D.C.

SPI Protocol

The SPI Protocol is a defined set of software commands enabling bi-directional data exchange between a master device and multiple slave devices, thus forming a manufacturing cell.

The protocol was developed to simplify vendor/user relationships by providing a predictable, flexible, and dependable communication system. For vendors, the protocol minimizes development costs, allows them to specialize in one protocol and offer an industry-wide recognized feature.

Control station

The station on a data communications link with the overall responsibility for monitoring the communications link and assuring the link's orderly operation. The control station has the responsibility for initiating recovery procedures in the event of abnormal conditions on the link.

Tributary station

A station on the data communication link that is not the control station.

Master station

Also known as the host or control station. A station that has control of the data communication link at a given instant. The assignment of master status to a given station is temporary and is controlled by the procedures set forth in the categories described in the SPI communication protocol standard. Master status is normally conferred upon a station so that it may transmit a message, but a station need not have a message to send to be nominated master.

Slave station

A tributary station that has been selected to receive a transmission from the station designated as the master station. The assignment of slave status is temporary, under control of the master station, and is continuous for the duration of the transmission.

Poll

A command from the master station to the slave station(s) which invites the transmission of data.

Select

A command from the master station to the slave station(s) which requests the reception of data.

VSD

Voltage sensing device used by the E5AX to monitor the status of the power supplied to external machinery.

Note For additional definitions used throughout this manual see the attached Glossary.

1-2 System Configuration

OMRON's E5AX Temperature Controller with SPI protocol communication is used to control a process temperature while the SPI Protocol Communication Board (E53-X03-SPI) within the E5AX translates process information between the E5AX and an SPI control station, and can be controlled by the processing machine's controller.

Fig. 1 shows a typical application, a molding station. The SPI control station is master to the E5AX controller, issuing commands to and requesting data from the SPI-equipped E5AX.

All stations on an SPI network communicate through the same cable; one station transmits at a time while the others listen. The SPI control station uses a user-specified device identifier (DEVID) and address to communicate directly with an individual tributary machine on the network. The E5AX can be set to one of four DEVIDs to specify the type of controller the E5AX is to function as: a mold TC, chiller, dryer or self-tuning general purpose TC.

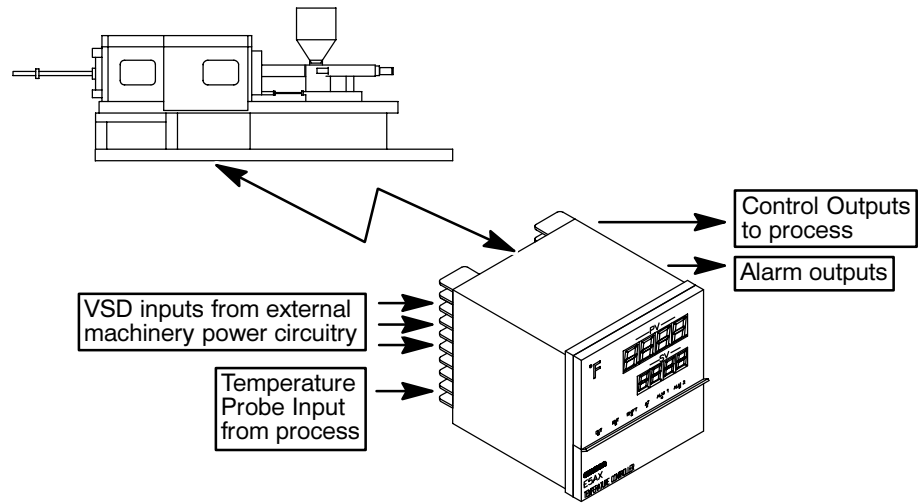

Fig. 1

1-3 Supported SPI Protocol Software Commands

Table 1

Controller Type	Command Function	Poll (hex)		Select (hex)		Required
Mold TC (DEVID 20h), Chiller (DEVID 21h), Dryer (DEVID 22h)	Echo	20	20	20	21	Yes
	Version	20	22	N/A		Yes
	Setpoint process temperature	20	30	20	31	Yes
	Alarm, high temperature deviation	20	32	20	33	Yes
	Alarm, low temperature deviation	20	34	20	35	Yes
	Status, process	20	40	N/A		Yes
	Temperature, to process	20	70	N/A		Yes

Table 2

Controller Type	Command Function	Poll (hex)		Select (hex)		Required
Self-tuning General Purpose Temperature Controller (DEVID 26h)	Echo	20	20	20	21	Yes
	Version	20	22	N/A		Yes
	Process setpoint 1	31	20	30-31	21	Yes
	Process value	31	22	N/A		Yes
	Alarm active status	31	2E	N/A		Yes
	Alarm 1 setpoint	31	2C	30-31	2D	No
	Alarm 2 setpoint	32	32	30-31	33	No
	Alarm 1 reset	N/A		30-31	35	No
	Alarm 2 reset	N/A		30-31	37	No
	Alarm 1 control	31	38	30-31	39	No
	Alarm 2 control	31	3C	30-31	3D	No
	Alarm hysteresis	31	42	30-31	43	No
	Controller status	31	44	N/A		No
	Autotune proportional band 1	31	46	30-31	47	No
	Autotune reset 1	31	4A	30-31	4B	No
	Autotune rate 1	31	4E	30-31	4F	No
	Autotune status	31	52	N/A		No
	Autotune controls	N/A		30-31	55	No
	Heat cool ratio	31	64	30-31	65	No

SPI compatibility has been achieved by this product's support of all required SPI commands and those non-required commands which the E5AX is capable of supporting. Furthermore, this product passes all tests of the SPI Machinery Division Committee on Communication Protocol (CCP) Simulation Software version 1.02, copyright SPI, 1989.

SECTION 2

Components and Switch Settings

2-1	Front Panel	6
2-2	Back Panel	7
2-3	Setting the E5AX Internal Switches	9

2-1 Front Panel

Key Descriptions

The following diagram identifies and briefly describes the major features found on the E5AX Temperature controller front panel. Slight differences in the front panel exist between models.

E5AX-A03-SPI

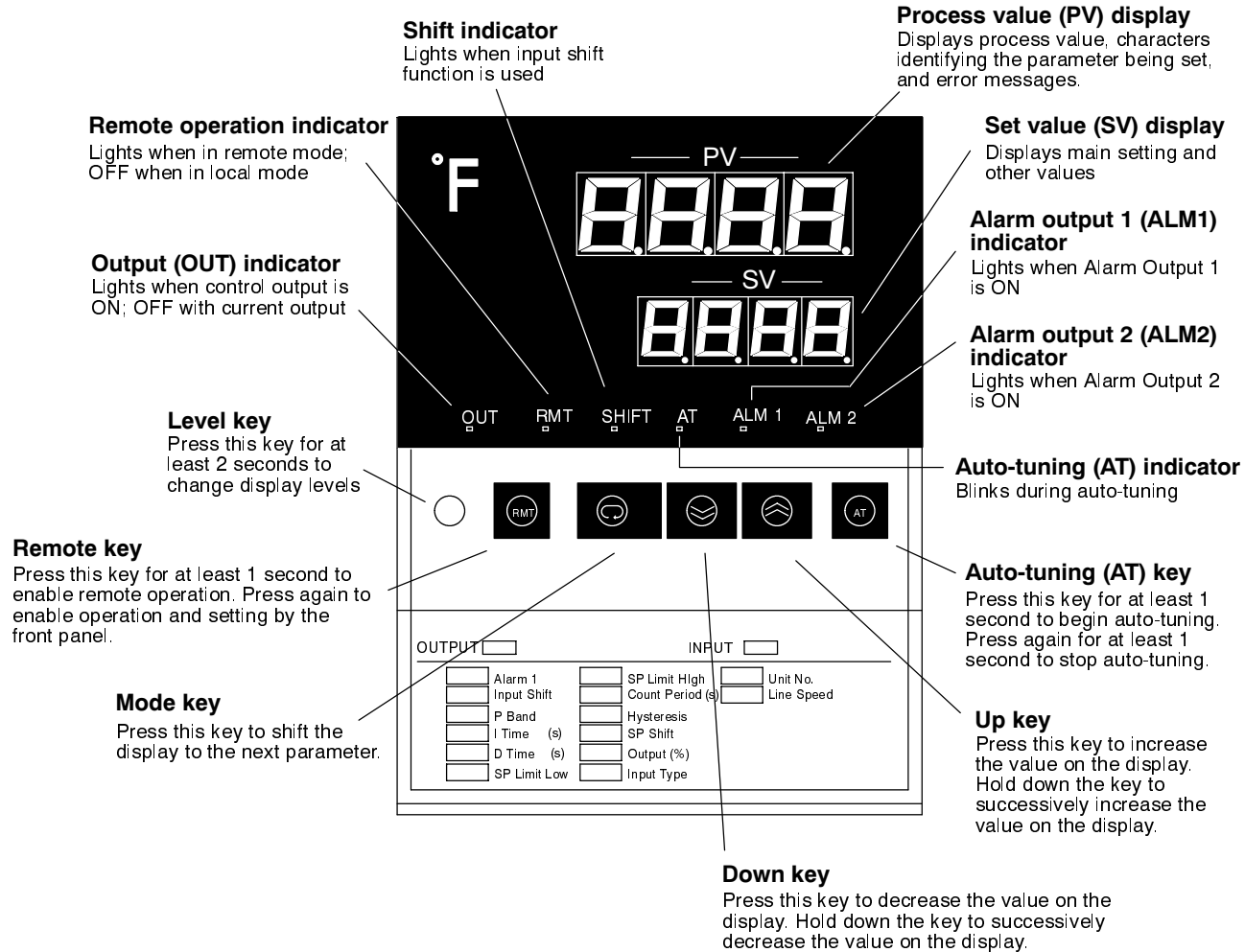

Fig. 2

E5AX-AH03-SPI is as above, but without the shift indicator and one alarm indicator. Additional indicators instead display heater burnout and sensor error conditions.

E5AX-VAA03-SPI is as above, but display both heat and cool output conditions, and only one alarm.

Remote & Local Modes

Remote Mode

Pressing the remote key for at least one second sets the E5AX to remote mode. In remote mode, the keys on the front panel cannot be used, except for monitoring the operation with the mode key and level key. Only in remote mode can communication using the SPI protocol have an effect on E5AX operation.

Local Mode

Pressing the remote key again sets the E5AX to local mode, enabling setting changes with the keys on the front panel. In local mode, the E5AX cannot be remotely controlled by either polls or selects from the master station. Changing from one mode to another cannot be remotely controlled.

2-2 Back Panel

Connector/Terminals

Communications Connector

A 9-pin D-Sub connector is used for connecting to the data communication link. Communications are executed using RS-485 as the hardware interface.

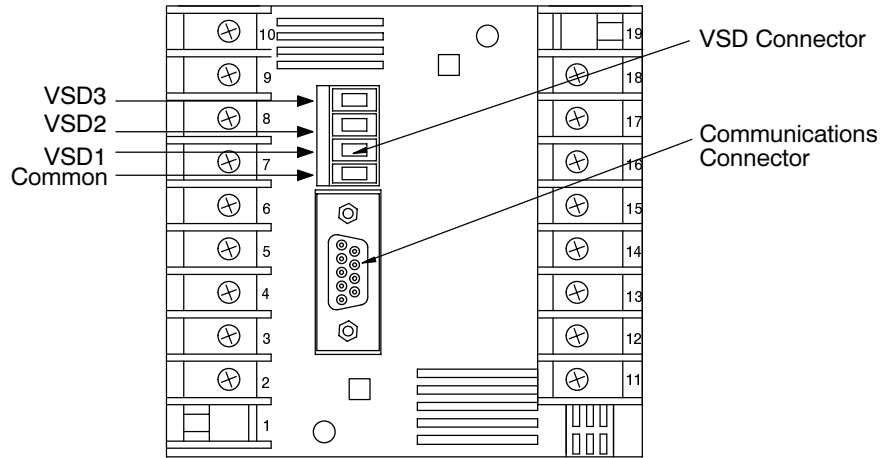

Fig. 3

VSD Connector: Weidmueller, Inc. SL4 12670.6 and BL4 12593.6 (external).

External Interface Requirements

RS-485 Interface

Pin 4 is connected to pin 8 on the SPI board.

Pin 5 is connected to pin 9 on the SPI board.

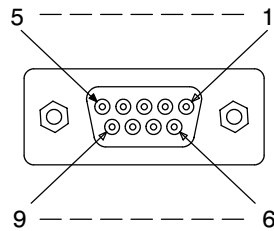

Fig. 4

Table 3

Signal name	Pin
Feed non-inverting circuit (transmit/receive +)	4
Feed inverting circuit (transmit/receive -)	5
Return non-inverting circuit (transmit/receive +)	8
Return inverting circuit (transmit/receive -)	9
Signal ground	3
Shield ground	1

E5AX Internal Communication Connection

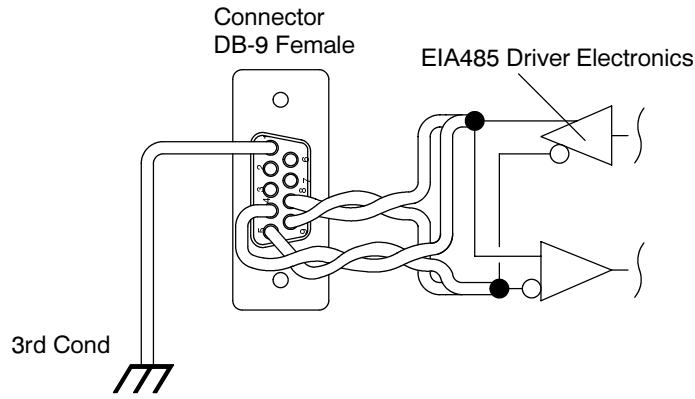

Fig. 5

Daisy-chain (Multi-drop) Connections of Multiple Stations

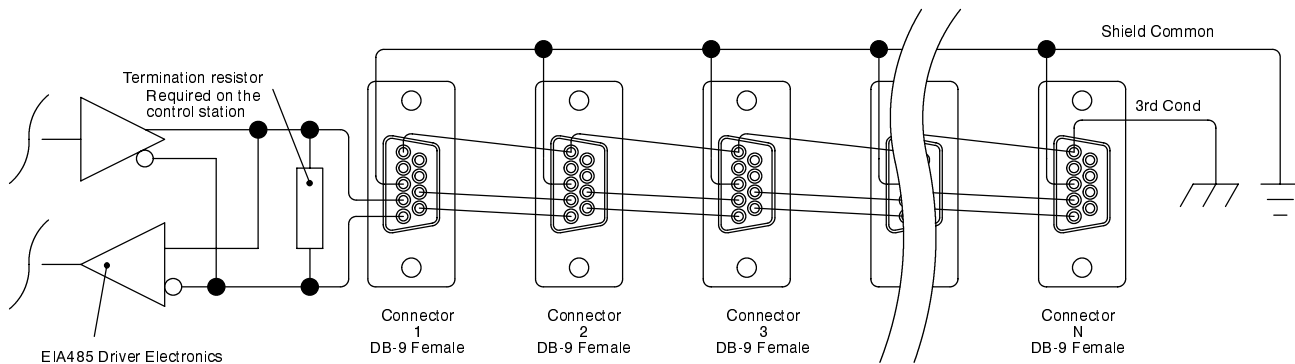

Fig. 6

VSD Input

- 3 VSDs to detect machine errors
- 120 VAC signal detection
- 4 connections (3 signal, 1 common); screw terminal type
- Connectors capable of supporting 22 to 14 AWG wire
- Active high/low switch affects the 3 inputs' logic simultaneously

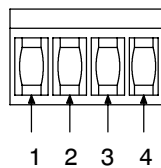

Fig. 7

Table 4

Signal name	Terminal
Voltage sensor common input	1
Voltage sensor 1 (VSD1)	2
Voltage sensor 2 (VSD2)	3
Voltage sensor 3 (VSD3)	4

Caution Never short-circuit or apply voltage exceeding that rated to the pins or terminals. Doing so will damage the internal circuit.

2-3 Setting the E5AX Internal Switches

Before applying power to the E5AX, set the internal switches by following the procedures outlined below.

DANGER! Disconnect power before working on any equipment.

Caution The E5AX components should be handled with extreme caution and only with proper grounding to protect the electronic components from possible damage by static electricity. Never short-circuit or apply voltage exceeding that rated to the pins or terminals. Doing so will damage the internal circuits.

Removing All External Cables

Before removing the internal mechanism from the housing, be sure that no cables are connected to both of the SPI board's connectors.

Caution If the SPI board is drawn out of the housing with the exterior cabling attached, the SPI board may be damaged.

To avoid the necessity of disconnecting the input lines, the VSD input connector itself can be removed from the SPI communications board. Simply press downward on the connector, then pull it free from the board, as shown in Fig. 8.

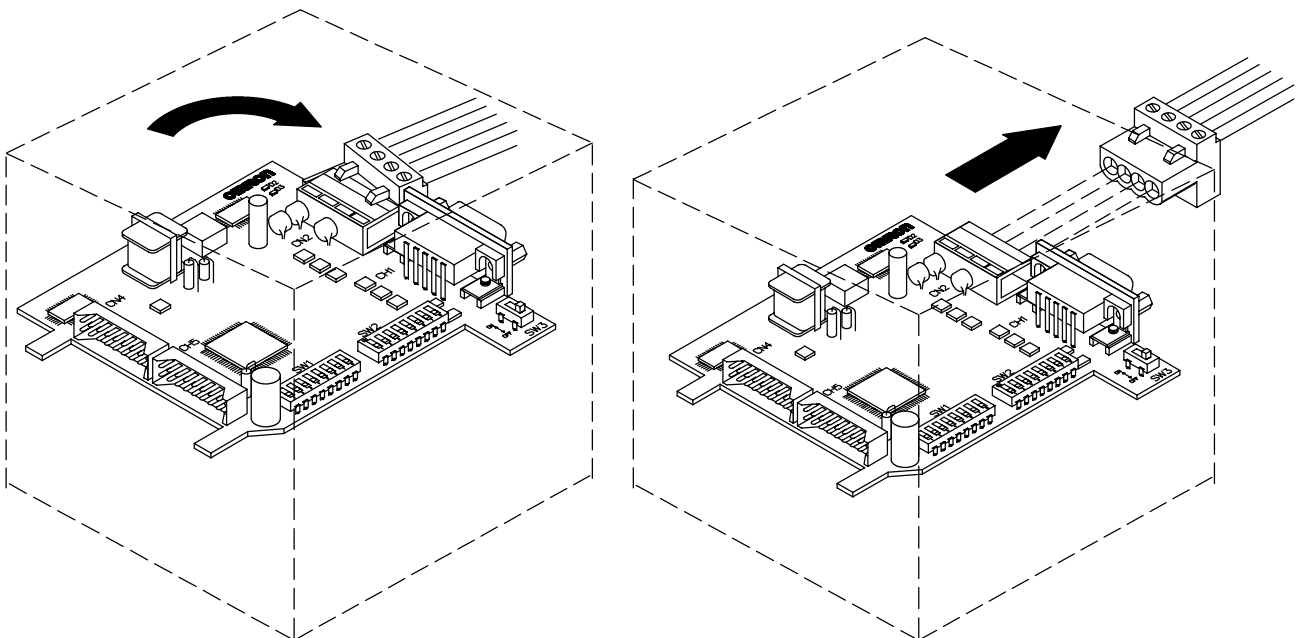

Fig. 8

Note Wires connected to the E5AX case terminals (numbered 1-19) are not affected by removing the internal mechanism. Those wires can therefore be left attached.

Removing the Internal Mechanism from the E5AX Case

Open the E5AX by pressing the hook (located on the bottom of the front panel) with your finger while pulling out the internal mechanism.

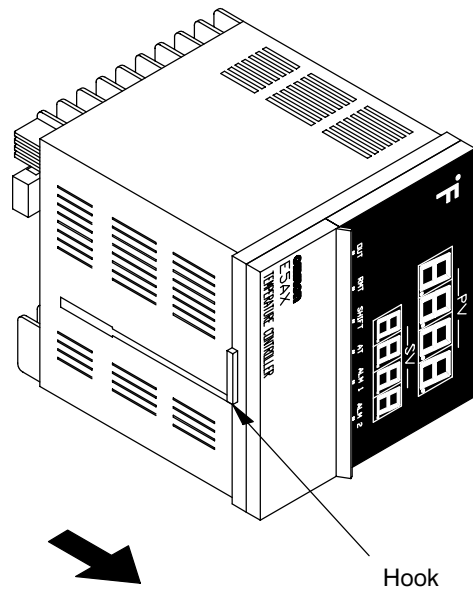

Fig. 9

Removing the SPI Board

Remove the SPI board by tilting it up and pulling it out of its internal connector.

Caution Be careful not to damage any wiring or other components.

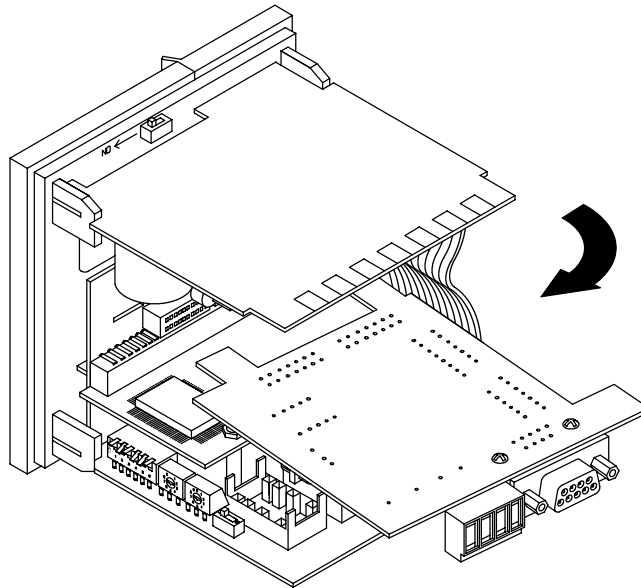

Fig. 10

Mounting or Removing the Output Unit

To mount the Output Unit, insert it in the direction shown by the arrow. Mount the Output Unit oriented so that the Output Unit's legs fit naturally into the socket.

When removing the Output Unit, be sure to first remove the SPI communications board, being careful not to damage the SPI board or the other internal components. Once the SPI board is removed, the Output Unit may be easily extracted using a small flat-blade screwdriver to pry it up.

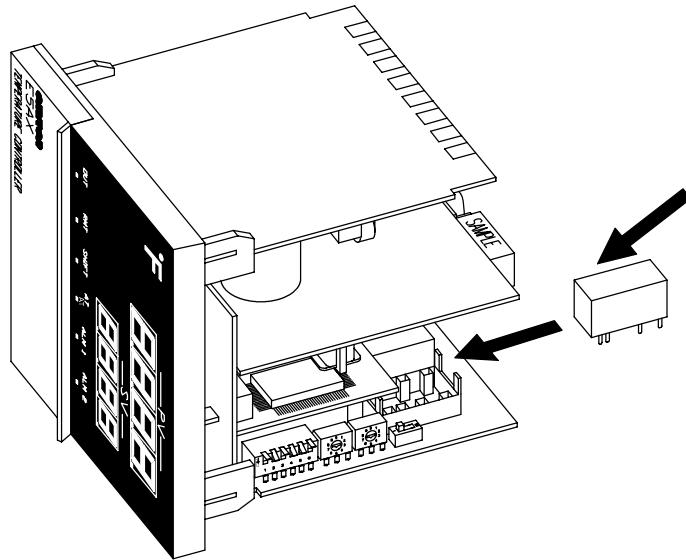

Fig. 11

Locations of Internal Switches

The E5AX-VAA03-SPI Temperature Controller requires 2 Output Units: 1 for heating, and 1 for cooling. Three sets of internal switches are located on the top right side of the controller.

- 1, 2, 3...**
1. The function selector SW201 (in-line DIP type) determines control mode, normal/reverse output, input shift, temperature sensor standard, scale indication (°C or °F), and PID constant indication where manual fine-tuning may be desirable.
 2. The alarm mode selector(s) set the alarm mode from the nine alarm functions available, including upper and lower limit alarms, upper limit alarm only, lower limit alarm only, upper and lower limit range alarm, alarms with standby sequence that eliminate nuisance alarms during start-up, event alarm and proportional alarm.

3. The output selector SW202 (a slide switch) must be set to the proper position for the type of Output Unit installed. For Relay, SSR, and voltage Output Units, set the switch to the PULSE position (OFF); for a current Output Unit, set the switch to the CURRENT position (ON).

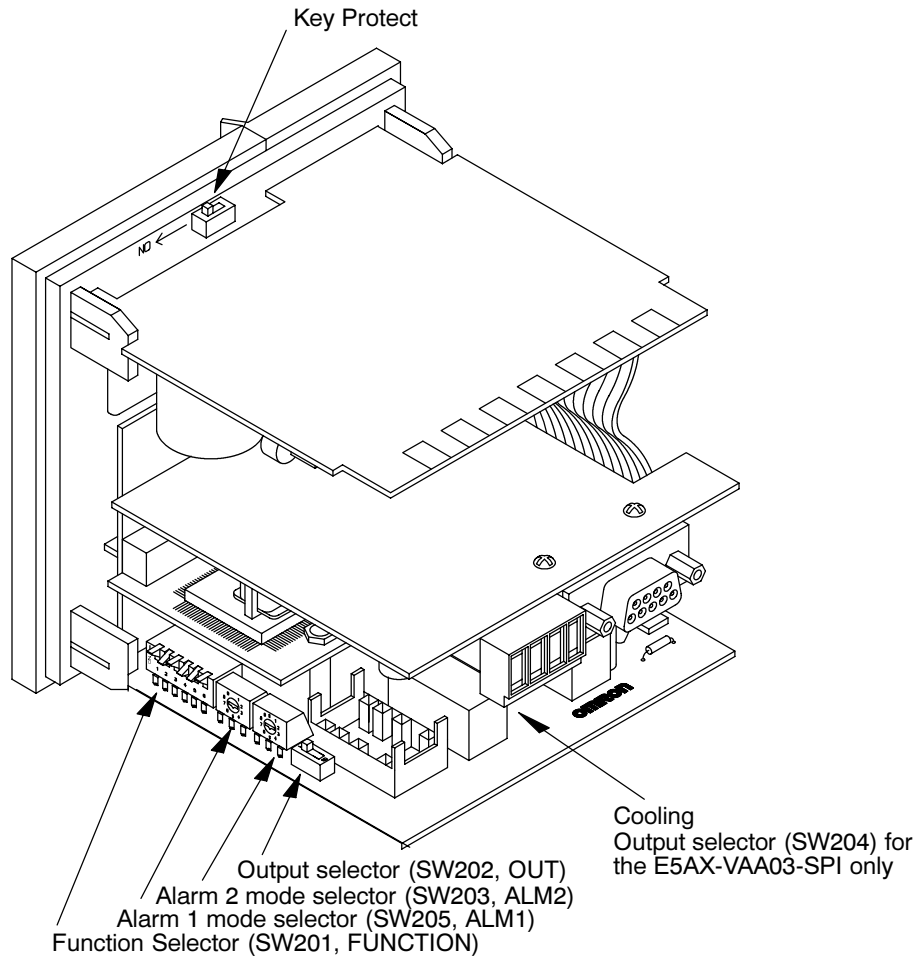

Fig. 12

The temperature sensor selector (rotary DIP type) is SW206, located on the bottom right side.

E5AX Switch Settings

Function Selection: SW201



SW201 Functions

Table 5

Function		Pin no.					
		1	2	3	4	5	6
Control mode*	ON/OFF	ON					
	PID	OFF					
Output operation**	Normal (Cooling)		ON				
	Reverse (Heating)		OFF				
Input shift data display	Enable			ON			
	Disable			OFF			
Temperature Sensor standard	DIN				ON		
	JIS				OFF		
Display units	°F					ON	
	°C					OFF	
PID constant data display	Enable						ON
	Disable						OFF
Factory setting		OFF	OFF	OFF	OFF	ON	OFF

*For the E5AX-VAA03-SPI Temperature Controller, both heating or cooling outputs will be set to the same control mode.

**For the E5AX-VAA03-SPI Temperature Controller, only normal operation is available with the cooling output; output operation is not selectable.

The SPI Protocol technically requires units to be in °F, however the E5AX can be set for °C if desired.

Advanced PID Control

Omron’s advanced PID control adds a feed-forward (FF) function to conventional PID control. In the diagram below, the conventional PID controller responds to disturbance (d) to quickly achieve stability. However, it overshoots the target value because it lacks sufficient control. Omron prevents overshoot in PID control by using a feed-forward function that is not affected by the disturbance. As shown below, the feed-forward function operates from the target value (r) to achieve fast response without overshooting the target value.

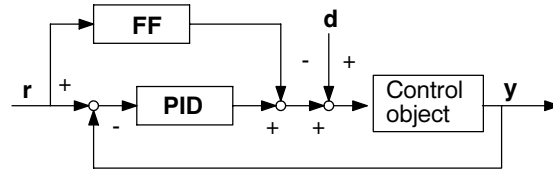

Fig. 13

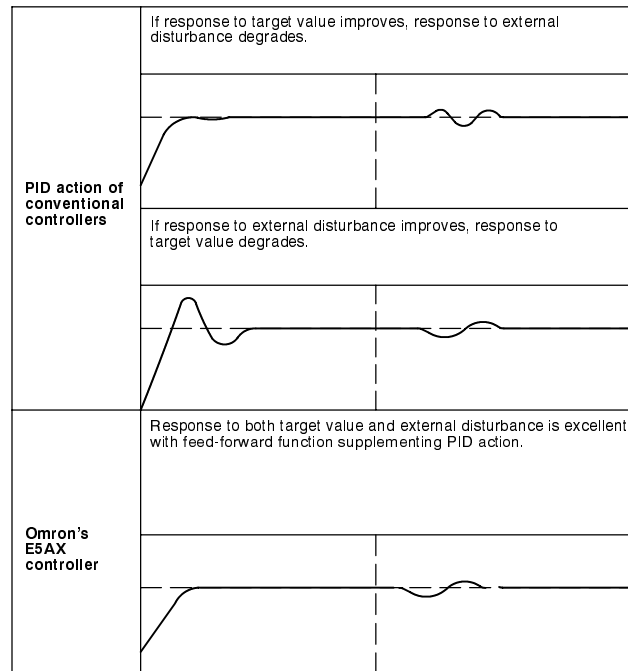

Fig. 14

Key Protection

The key protect switch is used to protect the controller against unauthorized front panel setting changes. When the setting key lockout switch (SW101) is set to the On position, the level key, up and down keys, and the auto-tuning (AT) key cannot be operated. In effect the Temperature Controller is write-protected and only the set values (such as alarm values) can be read out from the front panel.

Table 6

		Key Protect Switch*	
		OFF	ON
Mode key		Enabled	Enabled
Up key		Enabled	Disabled
Down key		Enabled	Disabled
AT key		Enabled	Disabled
Level key		Enabled	Disabled

*Factory setting: OFF

Output Selectors

Table 7

Pulse/Current Selector*	
Unit	Switch position
Relay Output Unit	Pulse
SSR Output Unit	Pulse
Voltage Output Unit	Pulse
Current Output Unit	Current

*Factory setting: PULSE

Alarm Mode Selection

One or two alarm mode selectors are provided depending on the exact model of E5AX: ALM2 (SW203) for all types and ALM1 (SW205) for E5AX-A03-SPI. Nine alarm modes, listed in the table below, can be selected using these switches. Alarm switches are factory set to position 2 for Upper Limit Alarm.

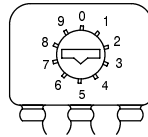

Fig. 15

Table 8

No.	Alarm mode	Character code in display level 2	Alarm output operation	Setting range
0	No alarm	Nothing displayed	Output off	
1	Upper- and lower-limit alarms]- - [-		0 to 9999 (TC)* 0 to 999.9 (Pt)**
2	Upper-limit alarm	- - - [-		-999 to 9999 (TC) -99.9 to 999.9 (Pt)
3	Lower-limit alarm]- - -		
4	Upper- and lower-limit range alarm	- [-] -		0 to 9999 (TC) 0 to 999.9 (Pt)
5	Upper- and lower-limit alarm with standby sequence	3 - - E		
6	Upper-limit alarm with standby sequence	- - - E		-999 to 9999 (TC) -99.9 to 999.9 (Pt)
7	Lower-limit alarm with standby sequence	3 - - -		
8	Event alarm	1 - - [-		
9	Proportional alarm	P r 0	Refer to the explanation that follows.	

*TC: Thermocouple

**PT: Platinum resistance thermometer

X: Alarm value

Y: An absolute value within the selected temperature scale range

Negative Alarm Values

If a negative value is set as X, the operation will be as follows:

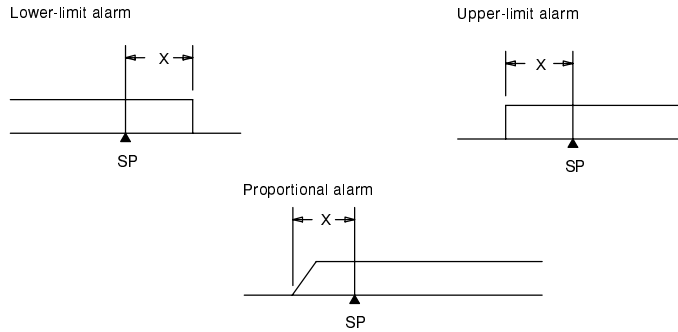

Fig. 16

Proportional Alarm

ALM 1 can be used to select the proportional alarm mode (Switch position 9) for E5AX-A03-SPI and E5AX-AH03-SPI only. Alarm mode 9 has no function for E5AX-VAA03-SPI.

The proportional alarm function is initiated when the temperature reaches a set alarm point (A in Fig. 17), which is the lower limit of a proportional band. When the temperature rises to the upper limit of the proportional band (point B in the figure), the alarm output is turned on.

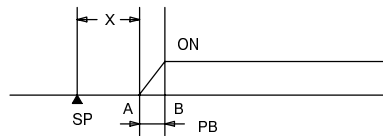

Fig. 17

Proportional band (fixed at 42°C/°F)

Proportional period is 20 seconds

The operation of the alarm function is not affected by pin 2 of the function selector (SW201).

Standby Sequence

Alarm functions with stand-by sequence suppress nuisance alarms when the controller is first powered up. Choosing alarm mode 5 eliminates nuisance alarms on both the high and low alarm; mode number 6 eliminates just the high alarm and setting number 7 just the low.

As shown in Fig. 18, the alarm output is suppressed until the temperature exceeds the alarm band or alarm limit one time.

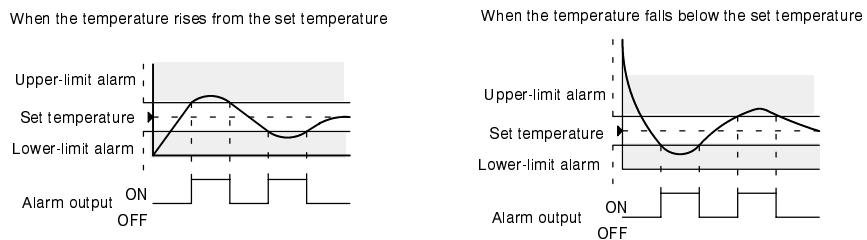
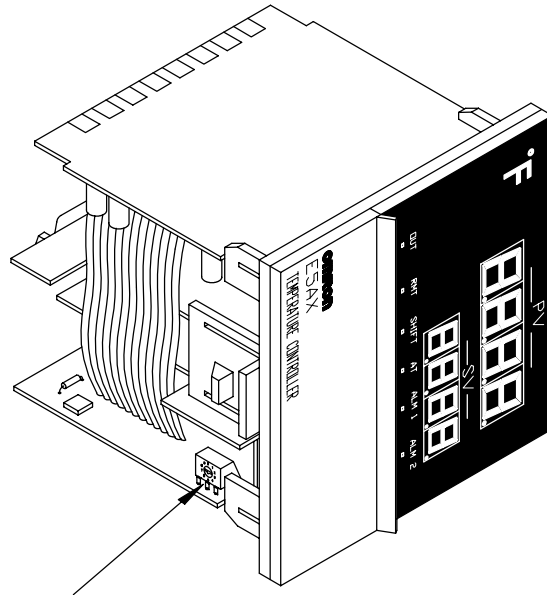

Fig. 18

Sensor Selector: SW206



Temperature sensor selector (SW206, INPUT)

Fig. 19

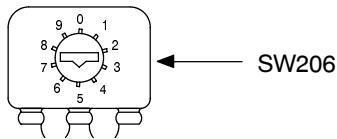

Fig. 20

Table 9

Selector	Sensor	Setting temperature range		Indication temperature range	
		°C	°F	°C	°F
0	R	0 to 1700	0 to 3000	-20 to 1720	-4 to 3128
1	S	0 to 1700	0 to 3000	-20 to 1720	-4 to 3128
2	K	-200 to 1300	-300 to 2300	-220 to 1320	-364 to 2408
3	J	-100 to 850	-100 to 1500	-120 to 870	-184 to 1598
4	T	-200 to 400	-300 to 700	-220 to 420	-364 to 788
5	E	0 to 600	0 to 1100	-20 to 620	-4 to 1148
6	JPt100	-99.9 to 450.0	-99.9 to 800.0	-99.9 to 470.0	-99.9 to 878.0
7	Pt100	-99.9 to 450.0	-99.9 to 800.0	-99.9 to 470.0	-99.9 to 878.0
8	L	-100 to 850	-100 to 1500	-120 to 870	-184 to 1598
9	U	-200 to 400	-300 to 700	-220 to 420	-364 to 788

Setting the SPI Switches

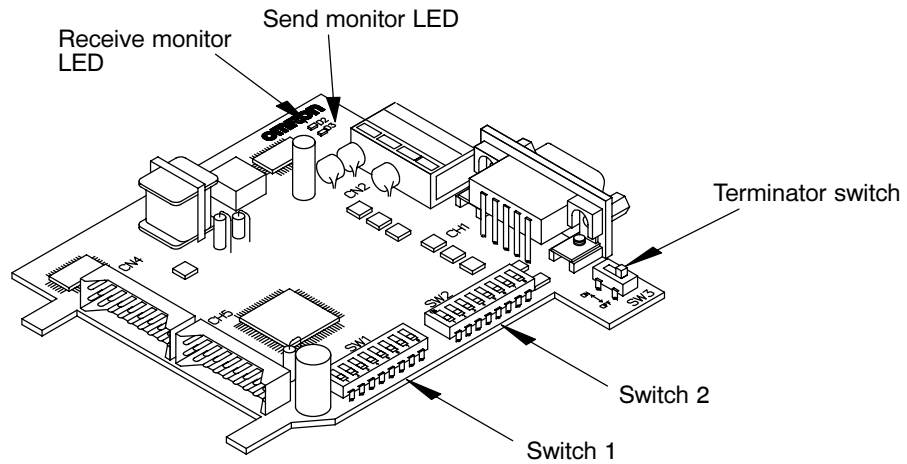

Fig. 21

SW1

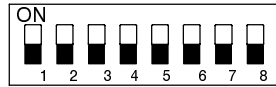

Fig. 22

Table 10

Function		Pin no.							
		1	2	3	4	5	6	7	8
Baud rate*	1200 baud	OFF	OFF	OFF					
	2400 baud	ON	OFF	OFF					
	4800 baud	OFF	ON	OFF					
	9600 baud	ON	ON	OFF					
	19200 baud	OFF	OFF	ON					
Device ID (decimal)**	32 (Mold TC)				OFF	OFF	OFF		
	33 (Chiller)				ON	OFF	OFF		
	34 (Dryer)				OFF	ON	OFF		
	38 (General TC)				ON	ON	OFF		
VSD inputs	Active high							OFF	
	Active low							ON	
Write mode of E5AX	Backup mode								OFF
	RAM write mode								ON
Factory setting		OFF	ON	OFF	OFF	OFF	OFF	OFF	OFF

*Other switch settings are regarded as 19200 bps.

**Other switch settings are regarded as 38.

Setting the Baud Rate: SW1, Pins 1 to 3

The baud rate determines the transmission speed for communications with the SPI control station. It is set by DIP switch 1 (SW1), pins 1 to 3 on the SPI board. Set the baud rate to the fastest rate available to the SPI control station's controller.

Setting the Device ID (DEVID): SW1, Pins 4 to 6

The device identification can be chosen from among the following list depending on how the E5AX is to be used.

Table 11

Device ID (decimal)	Device ID (hex)	Controller Type
32	20	Mold TC
33	21	Chiller

Device ID (decimal)	Device ID (hex)	Controller Type
34	22	Dryer
38	26	Self-Tuning General Purpose TC

The device ID is factory set to DEVID 32 (decimal).

Setting the VSD Inputs Active High/Low: SW1, Pin 7

Active high/low is set by DIP switch 1, pin 7.

When active high, VSD inputs 1 to 3 are regarded as logically high (1) when the input voltage exceeds 80 V relative to common. When active low, they are regarded as logically high (1) when the input voltage is below 10 V.

Process status or alarm status will change depending upon VSD input status. Unless all 3 VSDs are logically high, a machine error can be detected by the master station.

Unused VSDs must be set to logical high.

Only one common line should be used.

To configure, connect each VSD to one of the equipment's 120 V AC power lines and the common VSD input to the common power line of all VSD-monitored equipment.

DANGER! Care should be used when handling the VSD connector due to the possible presence of 120 V AC.

Note The SPI board is factory set to active high.

Setting the Write Mode: SW1, Pin 8

The write mode of the E5AX is set by DIP switch 1, pin 8.

The select value data sent from the master station is internally stored in the E5AX, which has non-volatile memory and RAM. The select value is stored in the non-volatile memory even when the power is turned off. The RAM, however, should be used instead of the non-volatile memory if the select value must be changed frequently while operating the E5AX. This is because the service life of the non-volatile memory, if it is used frequently, will be short when compared with the RAM.

The E5AX has two kinds of write modes (backup mode and RAM write mode), either of which can be chosen for data storage.

Backup Mode

In the backup mode, all set values are stored in non-volatile memory and RAM. This mode should not be selected if the value you set must be frequently changed (more than a few times a day in single value control operation, for example) while operating the E5AX.

The E5AX automatically enters its backup mode initially each time power is turned on. The non-volatile memory also stores data when the E5AX is in local mode.

The following block diagram shows the condition of data storage for the backup mode and local mode:

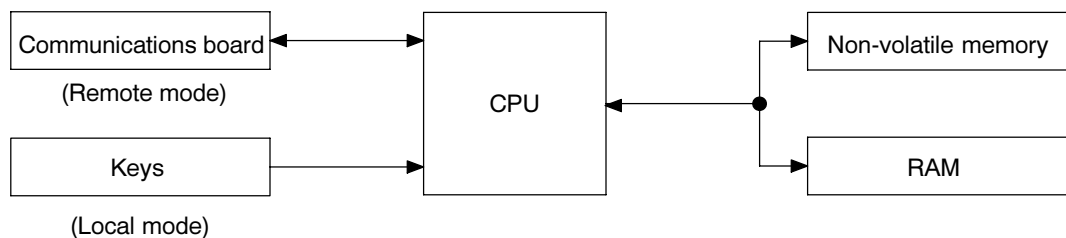

Fig. 23

Ram Write Mode

In the RAM write mode, all set values are stored in RAM while power is on. This mode should be selected if the value you set must be changed frequently (in program control operation, for example). Any set value stored in the RAM is lost when the power is turned off. Even if the mode is switched from Ram Write Mode to Backup Mode, the value cannot be written into the non-volatile memory.

The following block diagram shows the data storage in the RAM write mode.

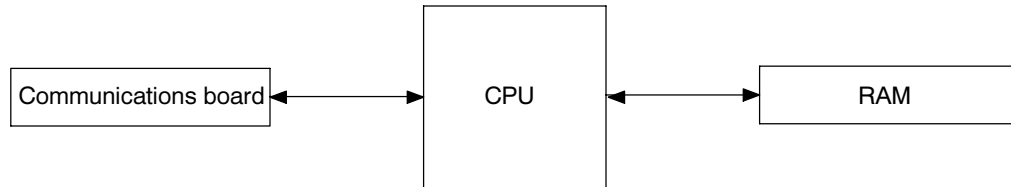

Fig. 24

Write Mode Selection and Remote/Local Modes

Switching from the remote mode to the local mode or vice versa does not affect the write mode which was previously set. Any values that have been set are automatically stored in the non-volatile memory when the mode is switched from the remote mode to the local mode. In the local mode, values are stored in the non-volatile memory regardless of the write mode that has been selected.

Note The SPI board is factory set to backup mode.

Setting the Address on the SPI Board: SW2

Each SPI tributary is assigned a specific address to enable easy identification of the various SPI tributaries during communication with the SPI control station. The same address may not be set for more than one tributary of each Device ID within the same network.

The address is set by DIP switch 2, and must be set within the range of 32 to 254. The settings of 0 to 31 are regarded as 32, and 255 as 254. Pins 1 to 8 respectively correspond to 2^0 to 2^7 .

Note The SPI board is factory set to 32.

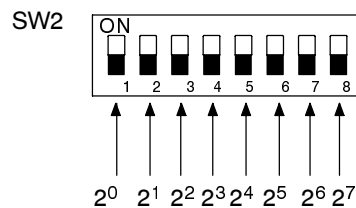

Fig. 25

Setting the Terminator: SW3

Turn ON the terminator SW3 of the E5AX at the end of the transmission line. All other units on the network must have SW3 turned OFF. Refer to Fig. 26. Refer to the SPI control station manufacturer's operation manual for its termination requirements.

Caution If a wrong controller is designated as the terminator, the operating current will increase, thus causing the Temperature Controller to malfunction.

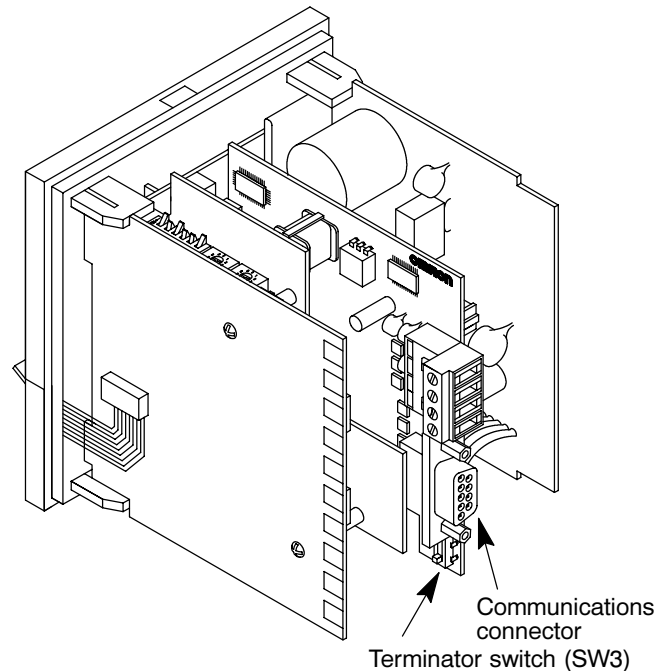

Fig. 26

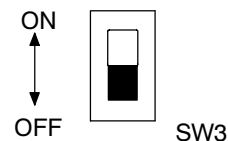

Fig. 27

Re-connecting Components

After all switch settings are completed, mount the SPI communication board onto the unit, and then insert the unit as far as it will go into the E5AX housing.

Caution Confirm that the hook at the bottom of the housing is securely engaged; otherwise, the internal mechanism may fall out when a cable is connected to the communication board's connectors at the back of the housing.

Wire the VSD connector. After normally tightening the VSD terminal screws, tighten another half-turn so that the lead wire is pressed down completely and locked to prevent loosening. Then confirm that the wire is properly fixed to the terminal. Attach the VSD connector to the SPI board.

Securely insert the communications connector from the external system into the communications connector on the Temperature Controller. After connection, tighten the screws on either side of the communications connector with a screwdriver. Refer to Fig. 28.

If you are using an equivalent connector, be sure that the connector screws are the following metric size: M2.6 x 0.45 mm.

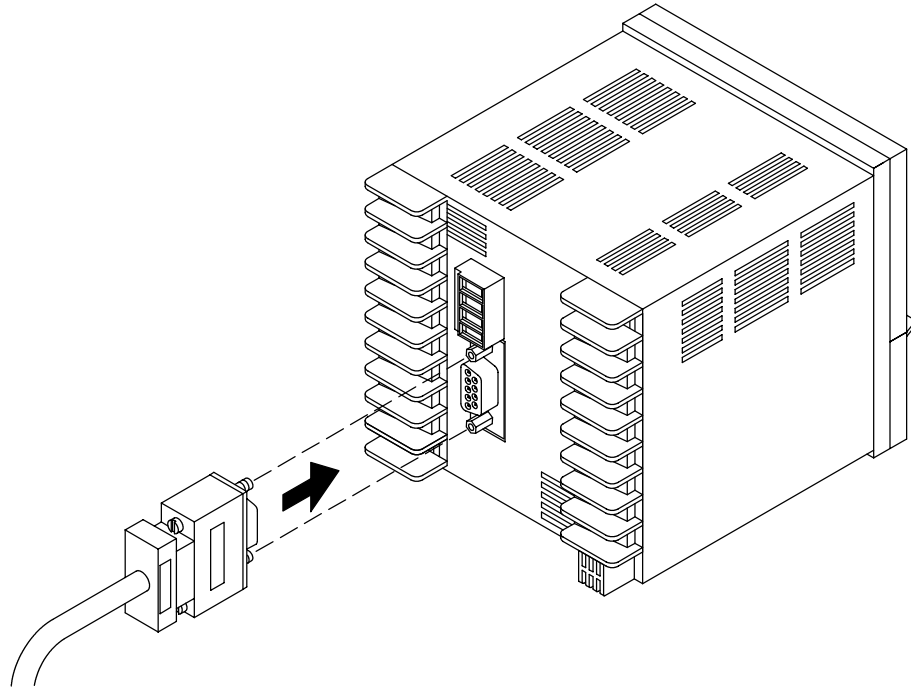

Fig. 28

SECTION 3 Installation

3-1	Wiring	24
3-2	Mounting	26

3-1 Wiring

Terminal Connections

The following are the terminal connections for the E5AX Temperature Controllers with SPI Protocol Communication Function.

E5AX-A03-SPI Temperature Controller

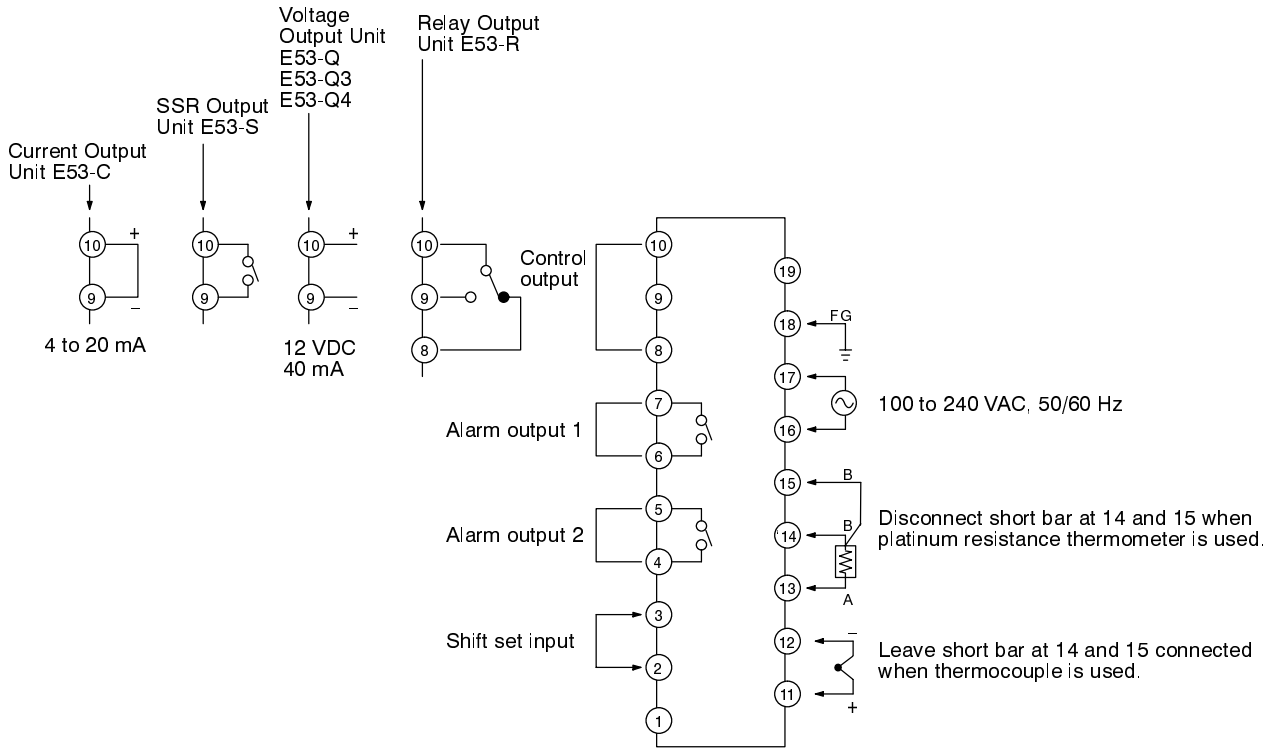

Fig. 29

E5AX-AH03-SPI Temperature Controller

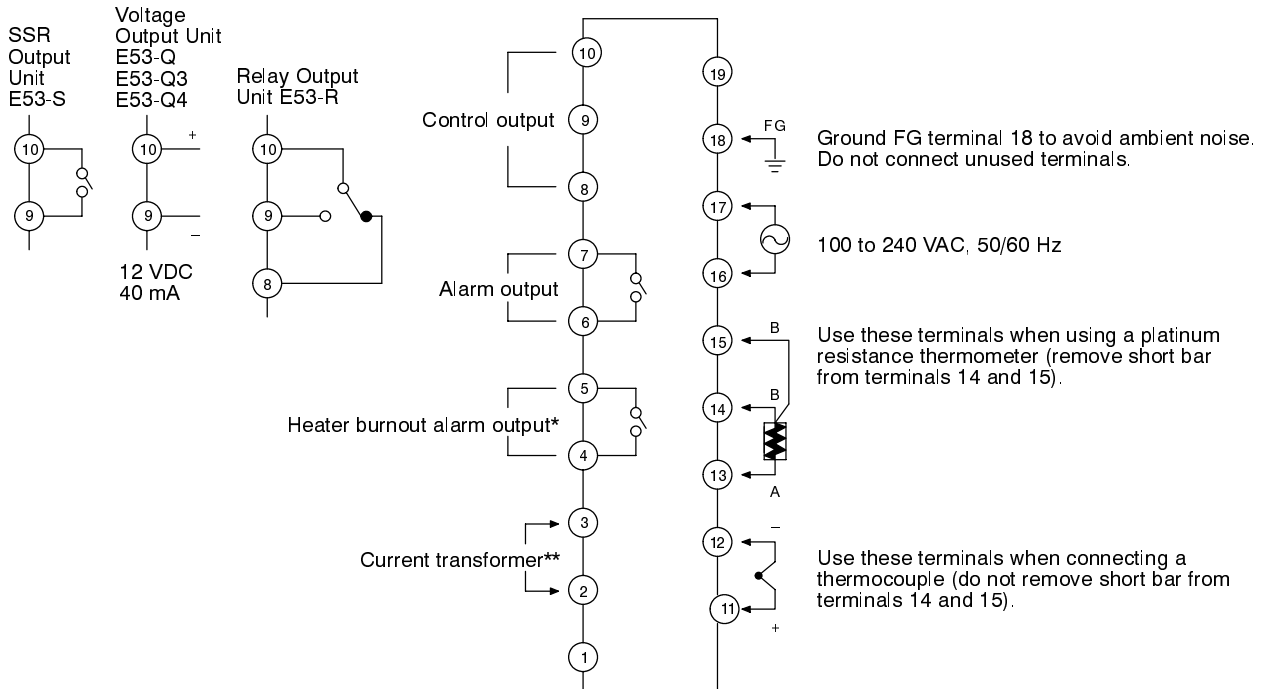

Fig. 30

* Heater burnout alarm output terminal is used to indicate both heater burnout and sensor errors.

** Current Transformer must be either E54-CT1 or E54-CT3.

E5AX-VAA03-SPI Temperature Controller

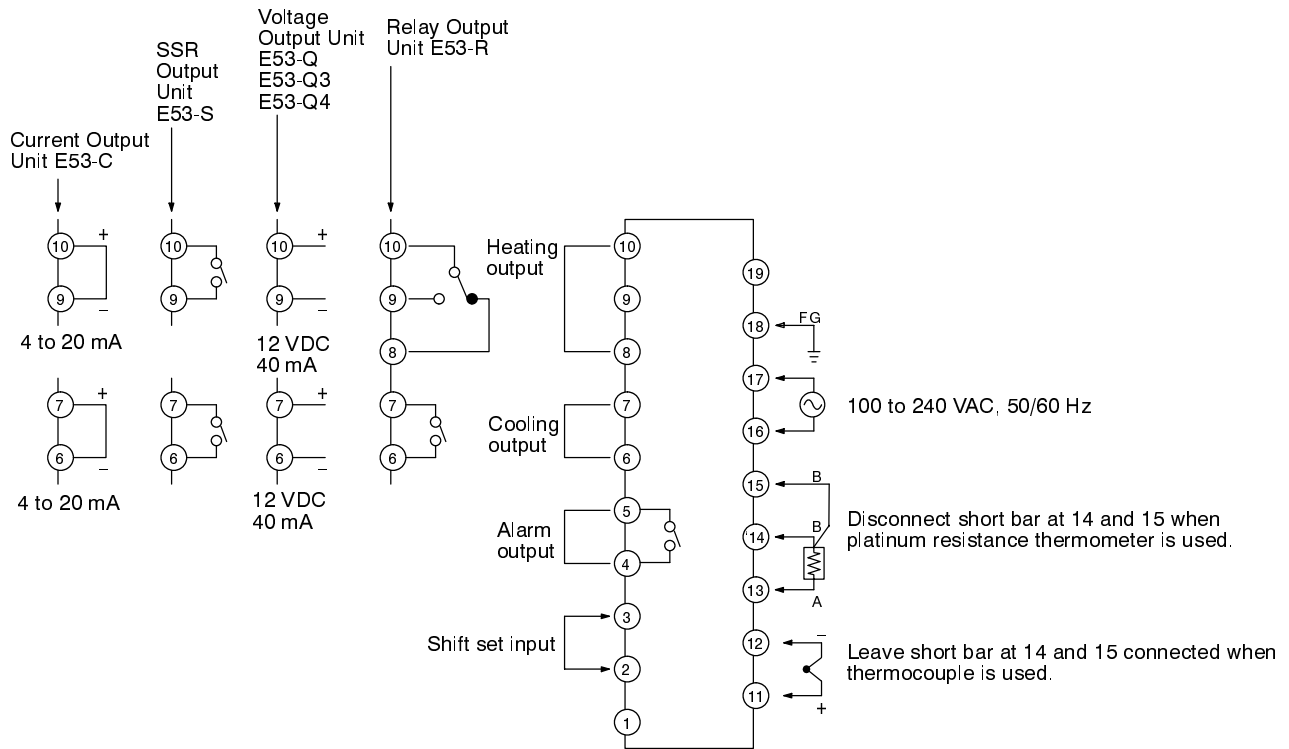

Fig. 31

- Note**
1. The field ground (FG) terminal 18 does not usually have to be grounded. Ground it through a resistance of less than 100Ω only when the Temperature Controller is placed in an electrically noisy environment.
 2. Do not use the vacant terminals.

3-2 Mounting

Communications Connector

Before mounting the Temperature Controller, be sure to consider the added depth required by connected cables.

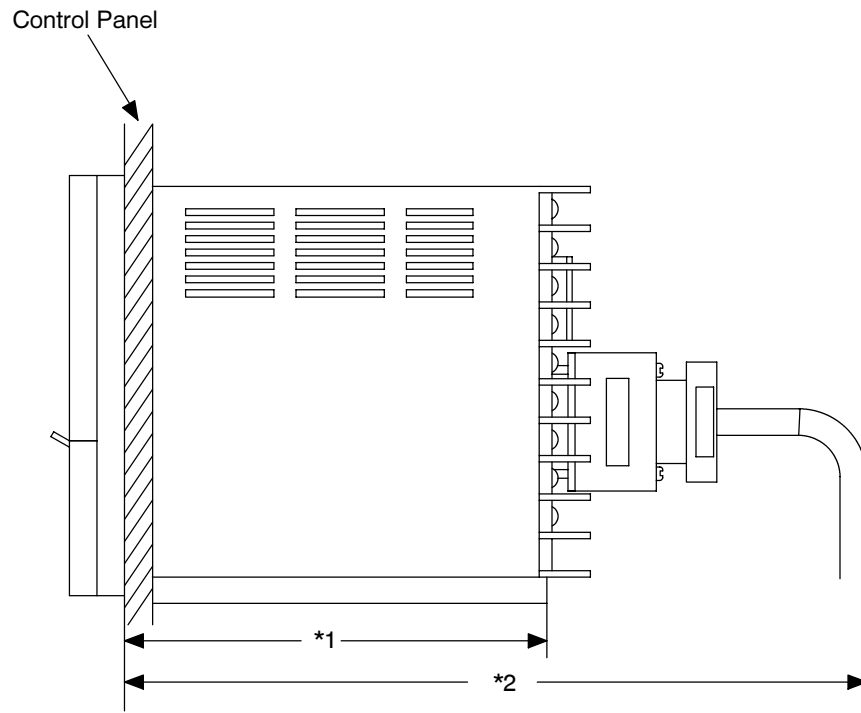

Fig. 32

Table 12

Depth of the main body from panel when mounted	
*1: Without OMRON XM4 D-sub Connector	*2: With OMRON XM4 D-sub Connector
100 mm	No less than 160 mm (9-pin connector)

The following OMRON D-Sub connector is recommended:

9 pin: XM4A-0921 (plug) + XM2S-0911 (hood)

Cable length: 500 m maximum (total)

Panel Cutout

The dimensions of the Temperature Controller conform to DIN 43700.

Recommended panel thickness is 0.04 to 0.32 inches.

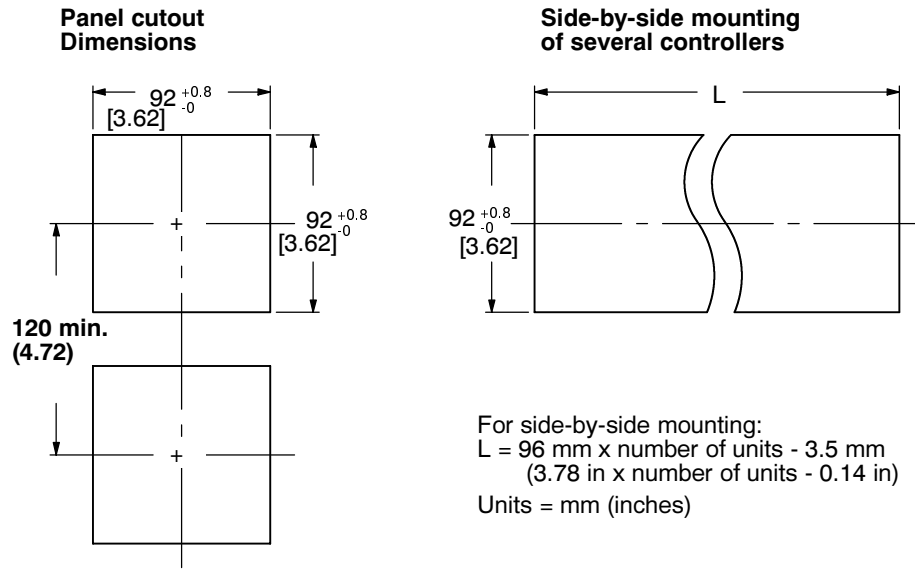

Fig. 33

Install the Temperature Controller in a location not exposed to excessive dust or corrosive gases. Locations exposed to heavy shock or vibration, water or oil sprays or high temperatures should also be avoided.

The E5AX Temperature Controller needs to be isolated from equipment that generates strong high-frequency electrical noise (such as welding equipment).

Mounting Brackets

To mount the E5AX into the panel, follow this procedure:

- 1, 2, 3...
1. Slide the unit into position
 2. From the back of the E5AX, attach the mounting brackets into the channels running back to front along the top and bottom of the E5AX. See Fig. 34 for the proper configuration.

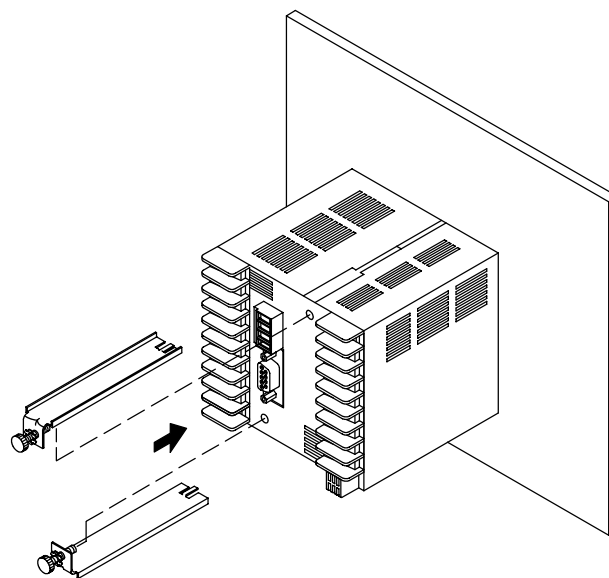

Fig. 34

3. Screw the finger-bolts into the E5AX; the clip at the front of the mounting bracket will grip the panel at the front of the unit.

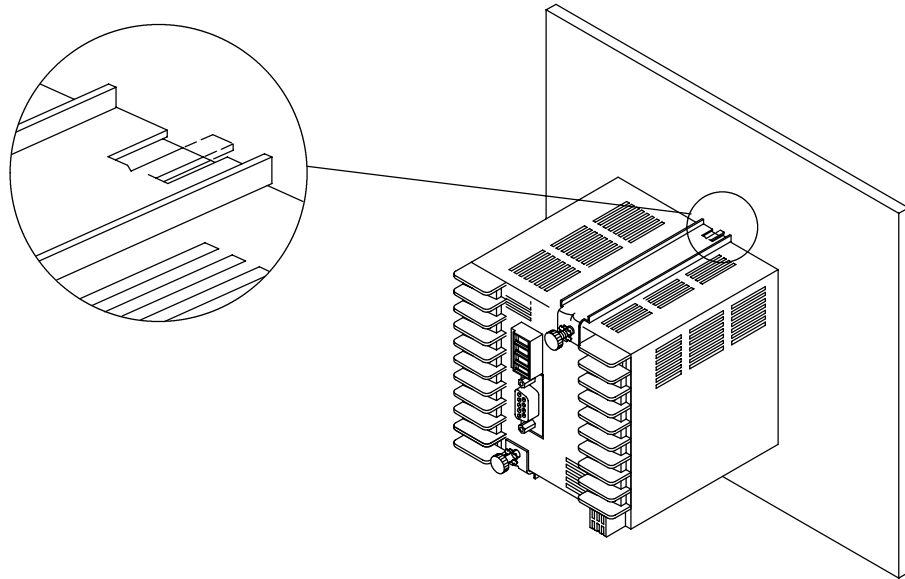

Fig. 35

E5AX Terminal Connection

Use M3.5 solderless terminals with the Temperature Controller’s M3.5 self-rising pressure plate screws.

For solder-dipped leads, strip 6 to 12 mm of the lead wire and carefully compact the wire tip.

Do not tighten the terminal screw with excessive force.

The terminal block of the Temperature Controller is constructed so that lead wires can be connected to all the terminals from the same direction.

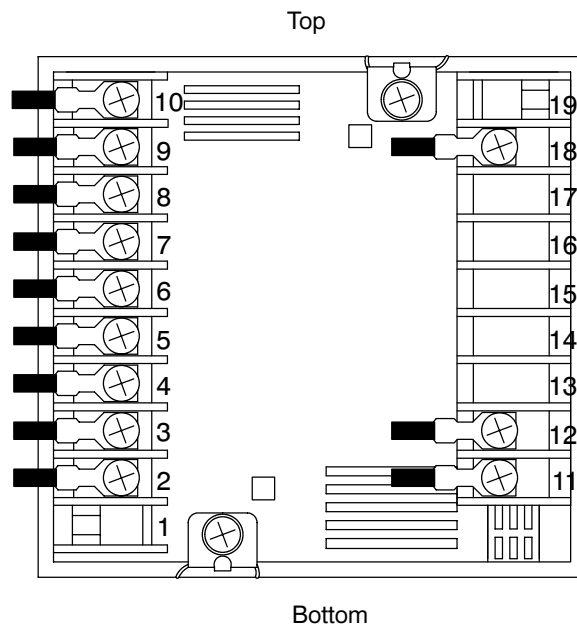

Fig. 36

Temperature Sensor Connection

To reduce induced noise, the lead wires connecting the temperature sensor to the Temperature Controller must be separated from the power lines and load lines wherever possible. Use the specified compensating conductors for thermocouples. When using a thermocouple as the temperature sensor, attach the short-circuit bar shown in the terminal block on the housing.

Use lead wires having a small resistance for platinum RTD sensors. Be sure to remove the short-circuit bar from the terminals when using the platinum RTD sensor.

Terminal Layout Diagram

The Temperature Controller allows an input and output device to be freely selected. Use the terminal layout diagram on the housing of the controller to identify the output device mounted in the Temperature Controller by marking the diagram as follows:

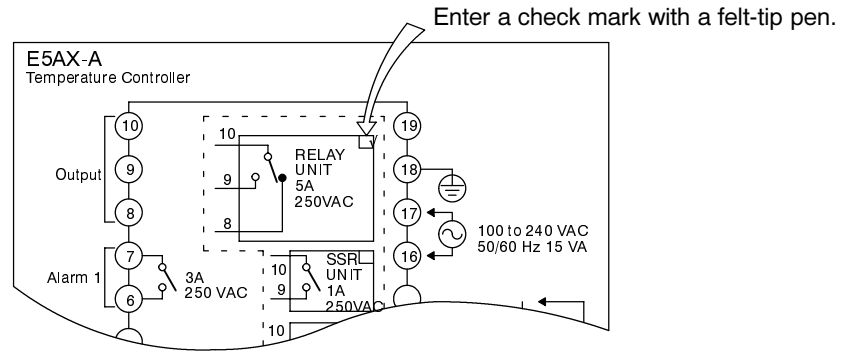

Fig. 37

Stickers

Stickers indicating the Temperature Sensor type and Output Unit are supplied with each unit. Attach these stickers on the front panel as shown so that the Temperature Sensor and Output Unit mounted in the Temperature Controller can be identified at a glance.

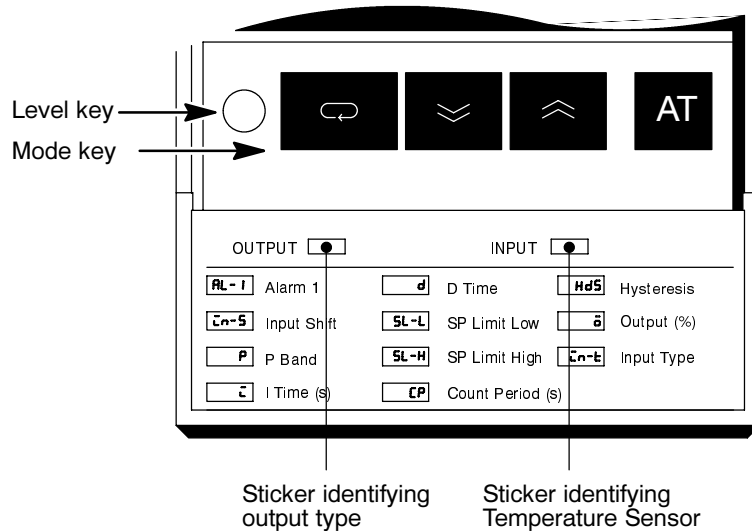

Fig. 38

SECTION 4

Operation

4-1	Setting the E5AX Controller	32
4-2	Programming the E5AX	33
4-2-1	E5AX-A03-SPI	36
4-2-2	E5AX-AH03-SPI	45
4-2-3	E5AX-VAA03-SPI	47

4-1 Setting the E5AX Controller

Before powering up after making switch setting changes, be sure the SPI board, the internal E5AX mechanism and all cables are properly inserted and connected.

Before attempting communications, set the baud rate to 9600 bps and the controller number according to the following procedures. Use the keys on the front of the E5AX to make the settings. Place the E5AX in local mode using the remote key.

The baud rate and controller numbers are set at display level 2.

The E5AX controller number (0) has no relation to the SPI communication address.

The E5AX internal baud rate (9600) has no relation to the SPI master/slave station baud rate set with the SPI board's SW1 pins 1 to 3.

Display Levels

The E5AX goes to display level 0 when power is turned on. The display level changes when the level key is depressed for two seconds or more. The display level contents at each level are shown in Fig.39.

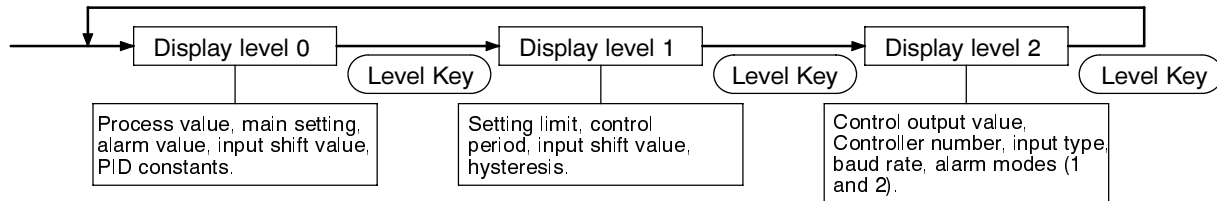

Fig.39

Mode level 2

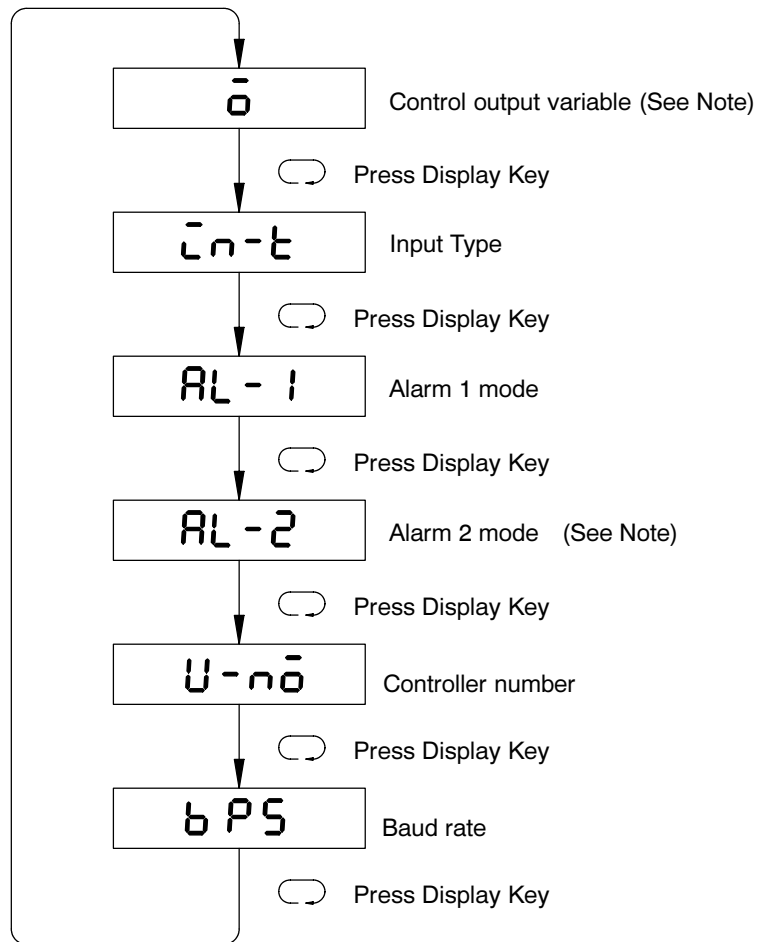

Fig.40

Controller Number U-n0

The controller number must be set to 0 to allow SPI Protocol communication. The Controller number is factory set to 0.

Baud Rate bPS

The baud rate must be set to 9600 to allow SPI Protocol communication.. The rate is factory set to 9600 bps.

Remote Mode

The Temperature Controller must be in remote mode to allow communication. Press the remote key for at least 1 second until the remote operation indicator (RMT) lights.

Note The set value becomes effective only after the E5AX's power is turned off once, and then back on again.

4-2 Programming the E5AX

Remote Programming

Refer to the host machine's operating instructions for enacting the following commands within the E5AX.

Refer to *Appendix F Communication Flowchart* for flowcharts which technically describe how the commands are communicated.

SPI Protocol Command Nomenclature

The following is a list of the E5AX-supported SPI Protocol commands and their definitions.

Use these commands when the E5AX is set for Mold TC, Chiller, and Dryer use:

Table 13

Command	Description
Echo	Controller integrity command. Controller will accept and retain the data provided. The controller will provide the retained data in response to a poll inquiry.
Version	Controller version command. The controller will provide a version number according to the following format: AABB, where AA = SPI assigned version level BB = Vendor assigned version level (use optional) If not used BB = 00.
Setpoint Process Temperature	Temperature at which the process is to be maintained. Units are assumed to be °F.*
Alarm, High Temperature Deviation	This value, in conjunction with the process setpoint, determines at what temperature the high alarm will occur. It must always be positive. Units are assumed to be °F.*
Alarm, Low Temperature Deviation	This value, in conjunction with the process setpoint, determines at what temperature the low alarm will occur. It must always be positive. Units are assumed to be °F.*

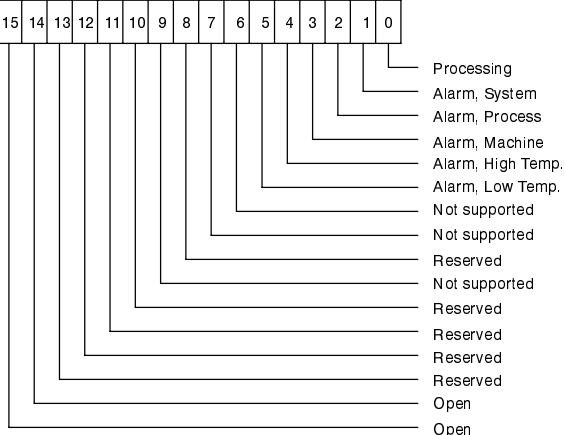
Command	Description
<p>Status, Process</p>	 <p>Processing Alarm, System Alarm, Process Alarm, Machine Alarm, High Temp. Alarm, Low Temp. Not supported Not supported Reserved Not supported Reserved Reserved Reserved Reserved Reserved Open Open</p> <p>Processing Bit#: 0 Required: Yes Description: This status bit states whether this unit is currently processing. 0 = not currently processing 1 = processing</p> <p>Alarm, System Bit#: 1 Required: Yes Description: This status bit states an alarm is present. The logical OR of process alarm and machine alarm.</p> <p>Alarm, Process Bit#: 2 Required: Yes Description: This status bit indicates that an alarm that affects the process has occurred.</p> <p>Alarm, Machine Bit#: 3 Required: No Description: This status bit indicates that an alarm that affects the machine operation has occurred.</p> <p>Alarm, High Temperature Bit#: 4 Required: Yes Description: This status bit states the temperature controller has exceeded its high setpoint deviation.</p> <p>Alarm, Low Temperature Bit#: 5 Required: Yes Description: This status bit states the temperature controller has exceeded its low setpoint deviation.</p>
<p>Temperature, To Process</p>	<p>Returns the Process Temperature. Units are assumed to be °F.*</p>

*The E5AX will return °C values if the appropriate DIP switch is set for °C display units.

Commands when the E5AX is selected for Self-Tuning General Purpose Temperature Controller use:

Table 14

Command	Description
Echo	Controller integrity command. Controller will accept and retain the data provided. The controller will provide the retained data in response to a poll inquiry.
Version	Controller version command. The controller will provide a version number according to the following format: AABB, where AA = SPI assigned version level BB = Vendor assigned version level (use optional) If not used BB = 00.
Setpoint Process Temperature	Temperature at which the process is to be maintained. Units are assumed to be °F.*
Process Value	Present actual temperature of the process.
Active Alarm Status	Indication of active alarms in the control system.
Alarm 1/2 Setpoints	Temperature at which alarm 1/2 is activated.
Alarm 1/2 Reset	Clears latched alarm conditions.
Alarm 1/2 Control	Disables and enables low hold (SPI standby sequence) and latched alarm conditions. Selects SPI alarm types.
Alarm Hysteresis	Temperature differential between the alarm activation and deactivation points.
Controller Status	Indicates: Power is applied to heaters; If temperature is above or below alarm setpoints; An open or shorted thermocouple; and If the controller is unable to maintain control of the process due to an A/D error.
Autotune Proportional Band	P value in units of degrees.
Autotune Reset	I value in units of seconds.
Autotune Rate	D value in units of seconds.
Autotune Status	Indicates tuning in progress, if tuning has been completed or if default parameters are being used.
Autotune Controls	Begins autotuning.
Heat Cool Ratio	Cooling proportional band as a percentage of the heating proportional band.

See *Appendix D Communication Protocol Specification* for a complete description of the command specifications.

Direct Programming

The Temperature Controller has three display levels, 0 to 2, in which only specific parameters can be set. Level 0 is the default and is automatically set during power up. To change the mode for a different set of parameters, hold down the level key for 2 seconds or more.

4-2-1 E5AX-A03-SPI

Level 0

In this level, the following parameters can be set or changed:

- 1, 2, 3...**
1. Alarm values
 2. Temperature values at which alarm outputs are to be produced
 3. PID constants
 4. Input shift values

When new values for these parameters are set, these values are displayed on the front panel's SV Indicator. Select the parameter you wish to edit by pressing the mode key the required number of times.

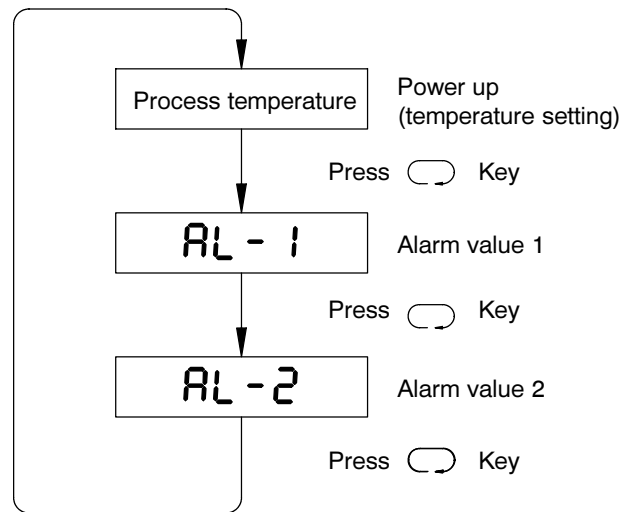

AL - 1

AL - 2

Fig.41

Setting the Alarm(s) Value(s)

On power up, the process temperature is displayed on the PV indicator.

When the mode key is pressed the PV indicator then displays AL-1, for alarm 1. Pressing the mode switch again displays AL-2, for alarm 2.

As the PV indicator shows AL-1 or AL-2, the alarm value for alarm 1 or 2, respectively, can be set on the SV indicator by pressing the Up or Down key.

Note The message AL-1 or AL-2 is not displayed if the corresponding alarm mode selector switch is set to No Alarm, position 0.

Setting the PID Constants

After setting the alarm 2 value, pressing the mode switch again will enable setting or editing of the PID constants, providing that pin 1 on the function selector (SW201) has been set to OFF, and pin 6 has been set to ON. The messages displayed on the PV indicator change with each press of the mode key; Fig.42 below identifies the individual changes.

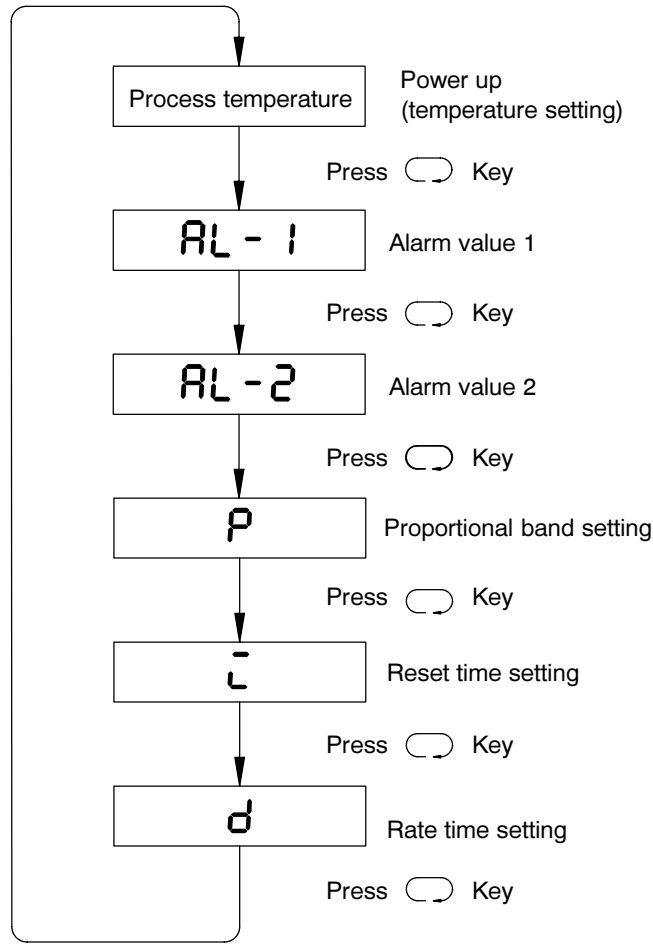

Fig.42

Proportional Band

While the character 'P' is displayed on the PV indicator, the proportional band (P constant) is set or changed using the Up or Down key(s). With a range from 0.0° to 999.9° in units of 0.1°, the new value will be displayed on the SV indicator as the value is entered.

The factory setting is 40.0°.

Reset Time

The reset time (I constant) can be set or edited when the character 'i' is displayed on the PV indicator. Use the Up or Down key to set or edit this constant's value. The allowable range is from 1 to 3,999 seconds in units of 1 second.

The factory setting is 240 seconds.

Rate Time

The rate time (D constant) is set and/or edited when the 'd' character is displayed in the PV indicator. Using the Up or Down key, set this value within a range of 0 to 3,999 seconds in 1 second units.

The factory setting is 60 seconds.

Setting the Input Shift

When pin 3 on the internal function selector DIP switch (SW201) is set to the ON position, the Input Shift function can be used. This function shifts the temperature display from a measured value to a desired value, as illustrated in the table below.

Table 15

Set input shift value	Temperature measured by sensor	Displayed temperature
0 (without shift)	100°	100°
10 (offset by 10°)	100°	110°
-10 (offset by -10°)	100°	90°

This function is used mainly for fine tuning compensation while leaving the set temperature unaffected. Select Input Shift by pressing the Mode Key 3 times in display level 0, as shown below.

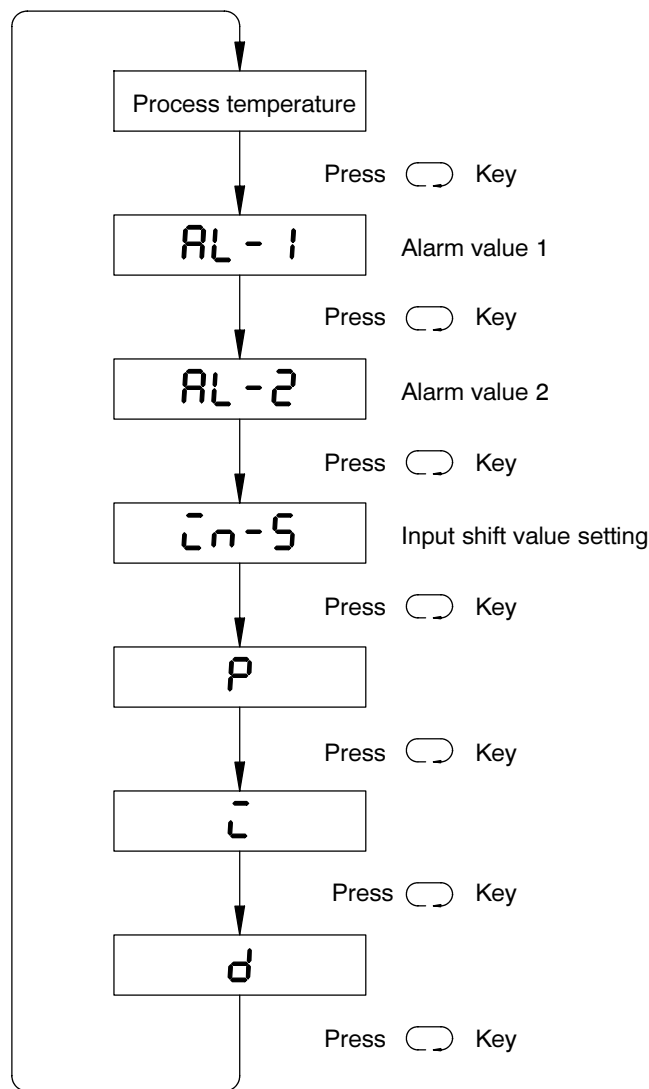

Fig.43

Input Shift Value

The range of Input Shift available depends upon the temperature sensor type. The following table shows the maximum values for a thermocouple or a Platinum RTD.

Table 16

Sensor input	Setting range	Units
Thermocouple	-999 to 9,999°C/°F	1°C/°F
Platinum RTD	-99.9 to 999.9°C/°F	0.1°C/°F

The input shift function remains effective even if pin 3 on the function selector DIP switch (SW201) is changed to the OFF position after the input shift value has been set.

If the displayed temperature does not need to be shifted, set 0° in response to the in-S message.

Level 1

In this level, the following parameters can be set or changed.

- 1, 2, 3... 1. Upper/lower limit values of the temperature setting range
- 2. Control period
- 3. Shift set value
- 4. Hysteresis

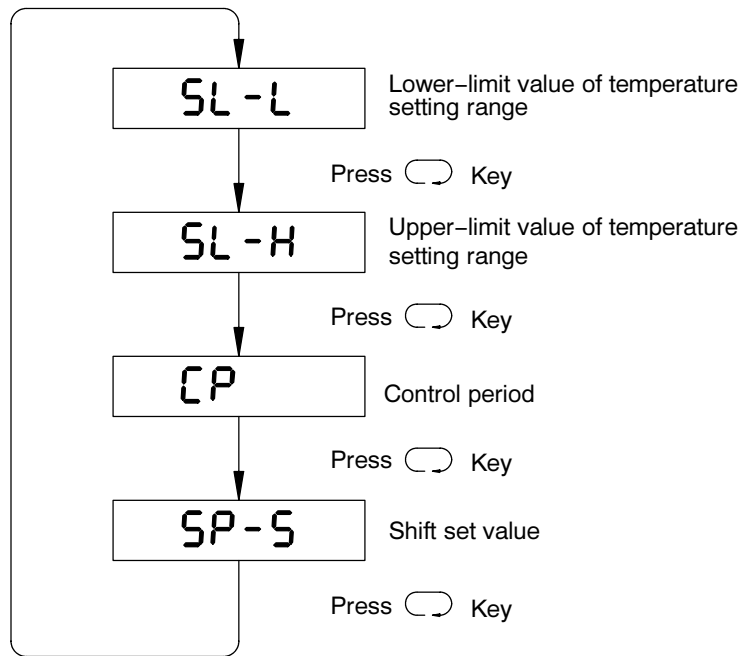

Fig.44

Limit Values

Lower Limit Value of the Temperature Setting Range **SL-L**
 Upper Limit Value of the Temperature Setting Range **SL-H**

The temperature range is determined by the temperature sensor type. For example, a type K Thermocouple offers a range between -300°F and 2300°F. However, the temperature setting range can be narrowed for an individual application, which for example, might only range between 0° and 400°.

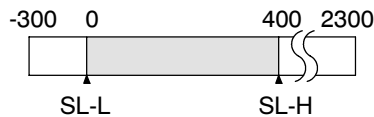

Fig.45

To use this function, set the lower limit value of the temperature setting range, in this case 0°, on the SV indicator by using the Up or Down key while the message SL-L is being displayed on the PV indicator. Press the Mode key once, then enter the upper limit value of the temperature setting range, 400°, while SL-H is displayed.

Control Period CP

The control period can be set under the following conditions:

- Pin 1 of the function selector DIP switch (SW201) is set to OFF (PID mode).
- The output selection switch is set to PULSE.

The Control Period range is 1 to 99 seconds, in 1 second units.

- Note**
1. The factory setting is 20 seconds.
 2. When a voltage or SSR output is used, OMRON recommends that the Control Period be set to 20 seconds or less (2 seconds is ideal) so that the control action can be performed more accurately.

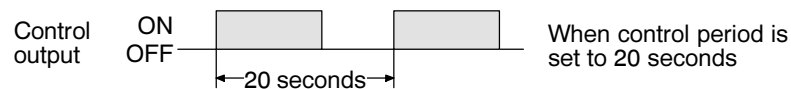

Fig.46

Shift Set Value SP-S

Pressing the Mode Key until the SP-S message appears on the PV indicator sets the condition for setting or editing an alternate Shift Set Value. This function shifts the setpoint temperature by a specified value.

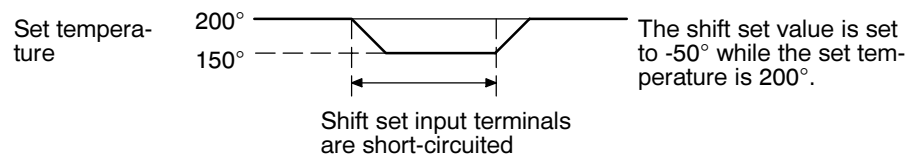

Fig.47

When the shift set input terminals are short-circuited, the SHIFT Indicator lights.

- Note** The Shift Set Value is factory set to 0.

Shift set is not available with the E5AX-AH03-SPI.

Hysteresis Value

The Hysteresis Value can be set under either of the following conditions:

- Pin 1 of the function selector DIP switch (SW201) is set to ON (ON/OFF Control).
- The Proportional band is set to 0° when pin 1 of the function selector (SW201) is set to OFF (PID control).

In these conditions, the Temperature Controller operates as if in ON/OFF control mode.

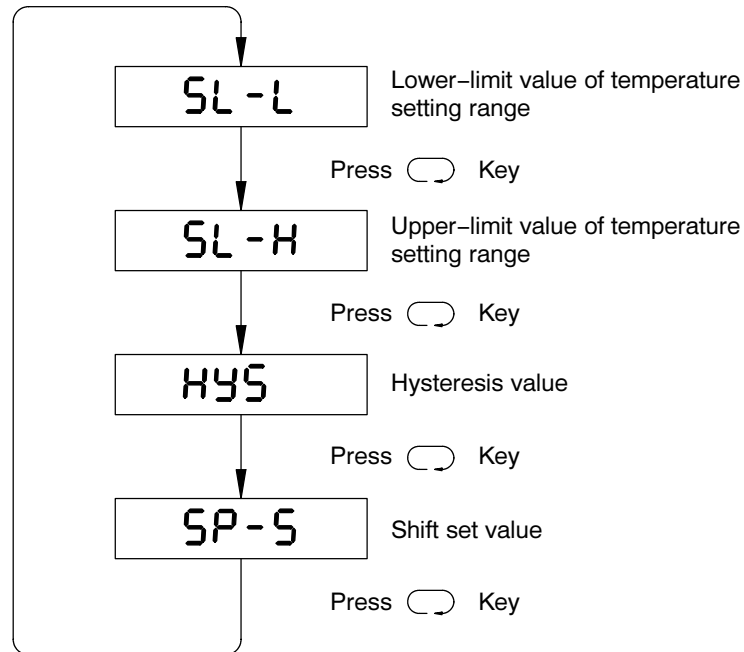

Fig.48

The Hysteresis Value for ON/OFF Control can be set in a range from 0.0° to 999.9° while the message HyS is being displayed on the PV indicator. Use the Up or Down key to adjust this value.

Note The factory setting is 0.8 °C/°F

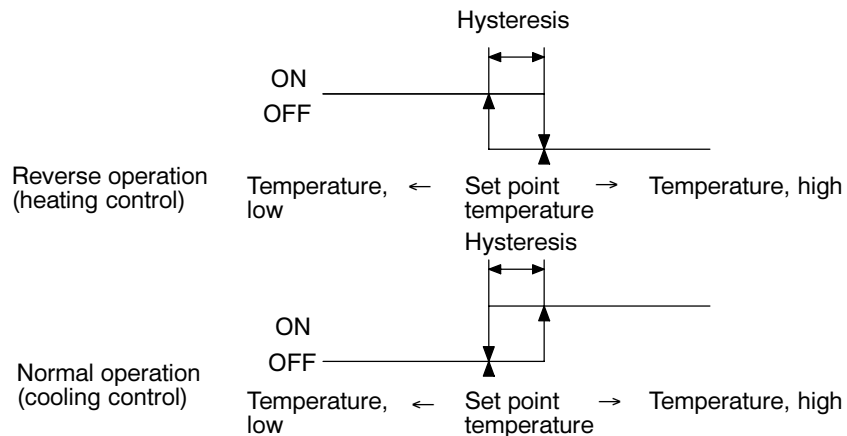

Fig.49

Level 2

Level 2 functions are exclusively for monitoring, no parameters are set. The control output variable, selected temperature sensor, and output alarm modes 1 and 2 are monitored through this level.

When the Level Key is depressed for more than 2 seconds after power up, the message SL-L is displayed on the PV indicator. After this message is displayed, holding down the Level Key for another 2 seconds displays the message 'o', indicating that the monitoring level has been reached.

Now, by depressing the Mode Key, the control output variable, selected temperature sensor, and/or output alarm modes 1 and 2 will be monitored with each Mode Key depression. See Fig.50 below for the correct sequence.

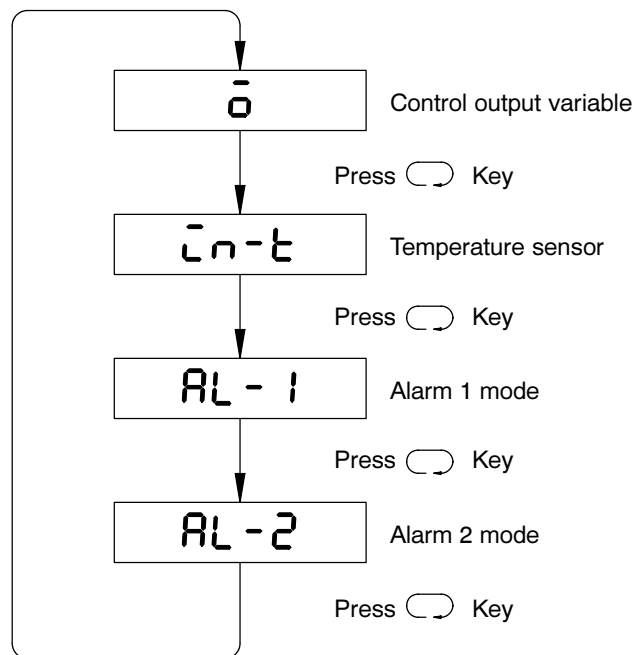

Fig.50

Control Output Variable 0

When the Temperature Controller enters Level 2, the Control output variable is displayed on the SV indicator in a range of 0.0 to 100.0 %.

Temperature Sensor t-n-t

When the message t-n-t is displayed on the PV indicator, a message identifying the selected temperature sensor, or the present setting of the temperature sensor switch (SW206) is displayed on the SV indicator. The table below shows the messages that may be displayed.

Table 17

Display characters	Sensor type
r Pr	Thermocouple type R
S Pr	Thermocouple type S
P CA	Thermocouple type K
J CC	Thermocouple type J
t CC	Thermocouple type T
E Cr	Thermocouple type E
J Pt	Platinum RTD (JIS 1981)
Pt	Platinum RTD (DIN)
LCC	Thermocouple type L
UCC	Thermocouple type U

Alarm 1 Mode **AL - 1**, Alarm 2 Mode **AL - 2**

When the message **AL - 1** or **AL - 2** is displayed on the PV indicator in Level 2, a message identifying the mode for alarm outputs 1 and 2, or the present setting of the corresponding alarm mode switches (SW205 and SW203) is displayed on the SV indicator. The following table shows the messages that may be displayed.

Table 18

Display characters	Alarm mode
No indication	No alarm function
]- - [Upper- and lower-limit alarms
- - - [Upper limit alarm
] - - -	Lower limit alarm
- [] -	Upper- and lower-limit range alarm
3 - - E	Upper- and lower-limit alarm with standby sequence
- - - E	Upper-limit alarm with standby sequence
3 - - -	Lower limit alarm with standby sequence
1 - - [Event alarm
Prō	Proportional alarm

4-2-2 E5AX-AH03-SPI

The following applies only to the E5AX-AH03-SPI.

Level 0

Only one alarm is available. All other details are the same as the E5AX-A03-SPI level 0 programming explanation.

Level 1

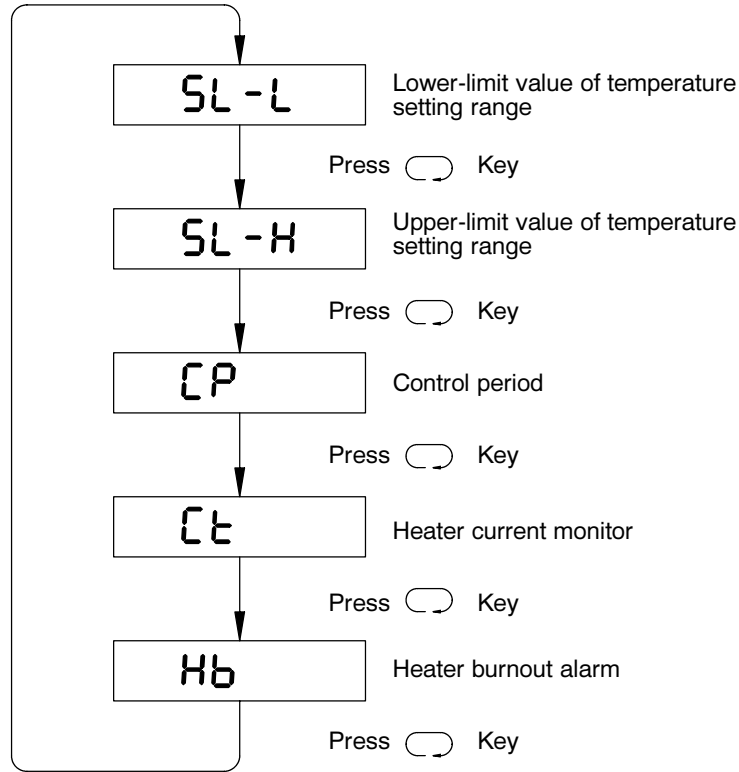

Fig.51

Heater Burnout Ct .Hb

To determine if the controller can detect the burnout of a heater in an individual system:

- 1, 2, 3... 1. Press the level key and mode key. The indicator displays Ct and the heater current, measured in amps.
2. Disconnect one of the heaters to simulate a burned out heater. Read the heater current.
3. The difference between the maximum rated current with all heaters and the rated current without one of the heaters must be at least 2.5 A. Otherwise, a burnout could go undetected.

To set the heater burnout alarm:

4. Calculate the desirable setting value of the heater burnout alarm using the values from steps 1 and 2.

$$\frac{\text{Current at normal state} + \text{current at heater burnout}}{2}$$

2

5. Press the mode key to display Hb, and set the value calculated in 4. (Setting range is 0.0 A to 50.0 A, in 1.0 A units. The maximum continuous heater current is 50 A. Do not apply more than 50 A.)

For example, if you were detecting heater burnout of three heaters, each at 200 VAC 1 KW and connected in parallel, you would first read the heater current in the normal state (15 A, in this example). After disconnecting one of the heaters, read the heater current again (10 A, for example). The difference between the maximum rated current with all heaters and the rated current without one of the heaters is 15 A - 10 A = 5 A, which is above the 2.5 minimum. Next, perform the calculation in 4.

$$\frac{15 \text{ A} + 10 \text{ A}}{2} = 12.5 \text{ A}$$

Set the heater burnout alarm to 12.5 A.

Table 19

Heater Burnout Alarm and Sensor Error Alarm		
Alarm	Heater burnout alarm	Sensor abnormality alarm
Output ON	Alarm output turns ON when heater burnout is detected.	Alarm output turns ON when sensor abnormality is detected.
Output terminal	Output is ON when either alarm is ON.	
Output display monitor	Hb on front panel is lit.	SENS on front panel is lit.
Output latching function	Yes	No
Output reset	Set heater burnout alarm value to 0.0 A or switch power OFF and then turn on power.	Output is OFF when sensor abnormal condition is solved.
Influence on control output/alarm output	None	Control output: OFF Alarm output: ON (proportional alarm output is OFF)

Level 2

Only one alarm is available. Otherwise see the E5AX-A03-SPI level 2 programming explanation.

4-2-3 E5AX-VAA03-SPI

The following applies only to the E5AX-VAA03-SPI.

Level 0

Only one alarm is available. All other details are the same as the E5AX-A03-SPI level 0 programming explanation.

Level 1

Dead Band $C-db$

This step sets an overlap band or a dead band for the cooling control output. When this value is negative an overlap band is set where both heating and cooling outputs are ON at the same time. When this value is positive, a dead band is set where both heating and cooling outputs are OFF. The dead band may be set between -999 and 999°C/°F.

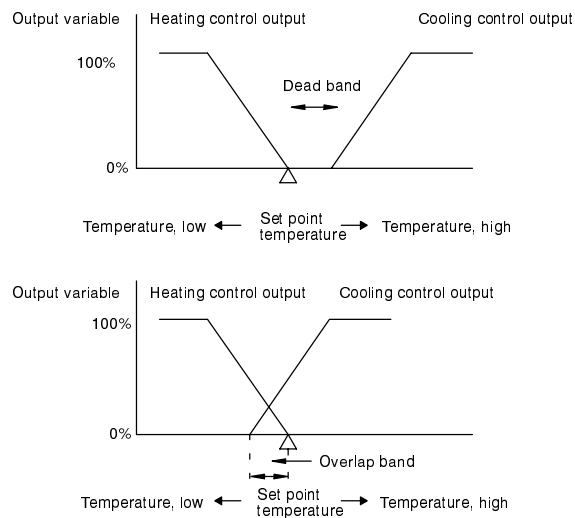

Fig.52

Cooling Coefficient $C-sc$

Sets the proportional band for cooling control output. The cooling coefficient can be set between 0.1 and 10.0; for models with communications, the range is 0.1 to 99.9.

$$\text{Cooling control proportional band} = \text{Cooling coefficient} \times \text{Heating control proportional band}$$

For example:

Heating control proportional band = 20°F

Cooling coefficient = 6

Cooling control proportional band = 120°F

Heating Control Period **CP**

Cooling Control Period **C-CP**

When Pin 1 on the function selector DIP switch (SW201) is set to the OFF position (PID control) and the output selector is set to the pulse position, the message CP is displayed on the PV indicator. The control period can be set or changed in a range from 1 to 99 seconds and in units of 1 second. The factory setting is 20 seconds. When a voltage or SSR output is used, it is recommended that the control period be set to 20 seconds or less (ideally, about 2 seconds), so that the control action can be performed more accurately.

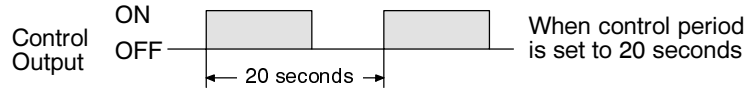

Fig.53

Heating Control Hysteresis **HyS**

Cooling Control Hysteresis **HyS2**

The hysteresis value for the ON/OFF control action can be set in a range from 0.0 to 999.9°C/°F while the message HyS or HyS2 is displayed on the PV indicator. Use the up or down key to do this. The factory setting is 0.8 °C/°F.

Level 2

Only one alarm is available. All other details are the same as the E5AX-A03-SPI level 2 programming explanation.

Automatic Tuning of PID

When the automatic tuning (AT) key is pressed for 1 second or more, the Temperature Controller automatically starts tuning the PID constants. While the automatic tuning is taking place the AT indicator on the front panel flashes.

The Temperature Controller executes control based on the previously-set or factory-set PID constants until the temperature of the controlled system reaches the set temperature. Factory-set PID constants are as follows:

Table 20

Constant	Value
P	40°C
I	240 seconds
D	60 seconds

After the tuning period, the Temperature Controller automatically adjusts the PID constants using the limit cycle method. After automatic tuning the AT indicator goes off.

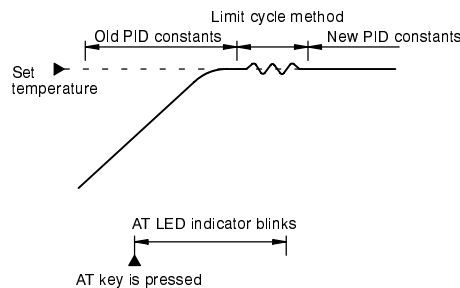

Limit cycle method: the optimum PID constants are calculated by this method by varying the control variable and generating external oscillation.

Fig.54

The automatic tuning can be carried out regardless of whether the Temperature Controller is performing reverse (heating) or normal (cooling) operation. To stop automatic tuning, hold down the AT key again for 1 second or more. Automatic tuning can be executed at any time:

- on power up,
- while the temperature is rising,
- and after control action has stabilized.

Continuous Self-recalibration

The electrical parts in Temperature Controller analog circuits are affected by temperature drift and deterioration from age. E5AX controllers have a built-in recalibration circuit that continuously monitors and calculates an offset value for the op-amp circuit. The calibration input voltage is applied every 3 seconds to keep the controller constantly calibrated. Factory recalibration is eliminated to reduce controller maintenance.

SECTION 5

Troubleshooting

5-1	E5AX Front Panel	52
5-2	Establishing Communication	52
5-3	Software Errors	58
5-4	SPI Protocol Error Byte	58

5-1 E5AX Front Panel

Error Messages

Table 21

Message	Cause	Control output		Alarm output
		With output unit other than current output unit	With current output unit	
FFFF	Overflow: Input temperature has risen beyond the upper limit of the temperature range by more than 20°C (68°F).*	OFF during reverse (heating) action ON during normal (cooling) action	4 mA during reverse (heating) action 20 mA during normal (cooling) action	Issues alarm outputs in accordance with the set alarm mode
----	Underflow: Input temperature has fallen below the lower limit of the temperature range by more than 20°C (68°F).**	ON during reverse (heating) action OFF during normal (cooling) action	20 mA during reverse (heating) action 4 mA during normal (cooling) action	Issues alarm outputs in accordance with the set alarm mode.
S.E.r.r (blinks)	The thermocouple has burned out or short-circuit bar has been removed. The platinum RTD has burned out or A and B have been short-circuited.	OFF	Approx. 1 mA	Issues alarm outputs in accordance with the set alarm mode. Proportional alarm output is OFF.
E111 E333 (blinks)	Memory failure (E111) or analog-to-digital converter failure (E333) has occurred. Temperature Controller must be repaired if recovery is not made by turning power off once and on again.	OFF	Approx. 1 mA	OFF

* When the type J thermocouple is used, this error message is not displayed until the temperature has risen above the normal operating temperature range by more than 70°C (158°F).

** When the platinum RTD sensor is used, this message is displayed when the temperature has fallen to -99.9°C (-147.82°F).

For the E5AX-AH03-SPI the following error message appears in case of a current transformer input error.

Message	Cause	Control output	Heater burnout alarm output
FFFF	Current transformer input current is over 50.0 A	Normal	Retains condition as it was before FFFF was displayed. Alarm output and sensor abnormality alarm output can function normally.

The system cannot operate when the E5AX detects overflow, underflow, sensor failure, or A/D error.

5-2 Establishing Communication

Receive/Transmit Check

To determine if the E5AX is receiving/transmitting data, look through the top of the back of the case. LED D2 blinks red when the E5AX receives data from the SPI control station. LED D3 blinks red when the E5AX sends data to the SPI control station. If the LEDs do not blink, there is a communication problem.

Before debugging the E5AX confirm the SPI control station is communicating properly. Refer to its manufacturer's operation manual.

Debugging the E5AX Communication Failure

Most common communication problems may be solved by following the following six steps. It is a good idea to establish communications with each SPI tributary station machine individually before attempting a complete network.

If these procedures fail, attempt to isolate the problem using the additional instructions found in this manual. If further assistance is required, contact your OMRON representative.

- 1, 2, 3...**
1. Is there power to the E5AX?
The front panel display LEDs will be lit if there is power to the internal mechanism.
Power-up Characteristics
When power is turned ON, temperature control is activated using the present parameters even while new parameters are being input. To operate the Temperature Controller after all of the new parameters are input, turn the power OFF once, then ON again.
The SPI board requires about 10 seconds after power is applied before it will operate. It will respond EOT to polls and Command Not Executed: NAK to selects during this time. When the power is turned ON or OFF, the SPI board may occasionally send some unnecessary characters. Several seconds are required until the relay is turned ON after power has been applied to the Temperature Controller. Therefore, take this time lag into consideration when designing a sequence circuit which incorporates the Temperature Controller.
If power is reaching the E5AX terminal block but the front panel display is not lit, confirm that the SPI board and the E5AX are securely inserted into their socket and housing respectively.
 2. Is the communication cable intact?
Loose, damaged or defective cables may be the problem. If they are securely connected and look intact, carefully check for continuity with a volt/ohm meter. Move the cable around when checking to discover possible intermittent connections.
 3. Are the baud rates set properly?
The SPI control station and all tributaries must be set to the same baud rate, or they will not communicate. Check the switch settings on the SPI board.
Cable length and plant noise may interfere with transmission. Try lowering the baud rate on the SPI board's SW1, pins 1 to 3 until communication occurs.
The SPI control station may need to be powered down for several seconds after the baud rate change for it to be in effect.
When errors are suspected to have been caused by noise, try executing communications repeatedly (approximately 10 times) until the E5AX returns to the normal operating condition.
 4. Are all addresses set properly?
The SPI control station must be programmed with the device types and unit addresses of the tributaries in its network. Check the switch settings on the SPI board.
If addresses are improperly set, the SPI control station will never communicate with the tributary station.
Check for duplicate addresses in tributaries of the same device identity. Problems could originate from two tributaries responding simultaneously.
 5. Are the device identity settings correct?
The control station must be programmed in agreement with each tributary's DIP switch setting. Check the switch settings on the SPI board.
If DEVIDs are improperly set, the SPI control station will never communicate with the tributary station.

6. Is the E5AX front panel properly set?

While in local mode, use the E5AX front panel to confirm that the unit number is 0 and the baud rate is 9600.

Check the E5AX front panel to ensure it is in remote mode while attempting communication.

Alarm, High Temperature Deviation

Table 22

Poll	20 32
Select	20 33
Format	Numeric
Range	0 to 3000 (Thermocouple) 0.0 to 999.9 (Platinum resistance)
Units	°F (or °C)
Poll Description	The SPI board will provide the high temperature deviation. If no data is selected after power on, the following is returned: 0.0.
Select Description	The SPI board will memorize and use high temperature deviation.

Alarm, Low Temperature Deviation

Table 23

Poll	20 34
Select	20 35
Format	Numeric
Range	0 to 3000 (Thermocouple) 0.0 to 999.9 (Platinum resistance)
Units	°F (or °C)
Poll Description	The SPI board will provide the low temperature deviation. If no data is selected after power on, the following is returned: 0.0.
Select Description	The SPI board will memorize and use low temperature deviation.

Status, Process

Table 24

Poll	20 40
Select	N/A
Format	16 Bits
Units	None
Poll Description	The SPI board will provide the status. Bit 0: Processing Bit 1: Alarm, System Bit 2: Alarm, Process Bit 3: Alarm, Machine Bit 4: Alarm, High Temp. Bit 5: Alarm, Low Temp. Bits 6-15: 0

Table 25

Name	Bit #	Status	Description
Processing	0	0	Not currently processing (1) Sensor failure, Overflow or Underflow (2) A/D error* (3) VSD error (VSD1 = 0, VSD2 = 0 and VSD3 = 0)
		1	Processing
Alarm, system	1		The logical OR of Alarm, Process (bit #2) and Alarm, Machine (bit #3).
Alarm, process	2		The logical OR of Alarm, High Temp. and Alarm, Low Temp. (bits 4 and 5).

Name	Bit #	Status	Description
Alarm, machine	3	0	0: Normal (VSD1 = 1, VSD2 = 1 and VSD3 = 1)
		1	Abnormal (1) Sensor failure, Overflow or Underflow (2) A/D error* (3) Internal communication error (4) VSD error VSD1 = 0, VSD2 = 0 and VSD3 = 0 VSD1 = 0, VSD2 = 0 and VSD3 = 1 VSD1 = 0, VSD2 = 1 and VSD3 = 0 VSD1 = 0, VSD2 = 1 and VSD3 = 1 VSD1 = 1, VSD2 = 0 and VSD3 = 0 VSD1 = 1, VSD2 = 0 and VSD3 = 1 VSD1 = 1, VSD2 = 1 and VSD3 = 0
Alarm, high temperature	4	0	Alarm not active
		1	Alarm active
Alarm, low temperature	5	0	Alarm not active
		1	Alarm active

*A/D error does not include Memory error because the E5AX does not support Memory error on communication.
(Active high mode: Logical 0 : Input ≤ 10 VAC, Logical 1 : Input ≥ 80 VAC)
(Active low mode: Logical 0 : Input ≥ 80 VAC, Logical 1 : Input ≤ 10 VAC)

Temperature, To Process

Table 26

Poll	20 70
Select	N/A
Format	Numeric
Units	°F (or °C)
Poll Description	The SPI board will provide the process temperature from the temperature controller and memorize it into the SPI board. The process temperature will be provided to the SPI board independently from the communication between the SPI board and the control station. When the SPI board has no process temperature because of internal communication error, the SPI board will reply EOT.

Chiller

Table 27

DEVID	21
Description	Cold water processing units
Commands	See Mold TC above

Dryer

Table 28

DEVID	22
Description	Material drying units
Commands	See Mold TC above

Self-tuning General Purpose Temperature Controller

Table 29

DEVID	26
Description	Single and multi zone temperature controls. In order to accommodate control systems with multiple zones within a single control, the CMD1 byte is used to direct a command to a particular zone where appropriate. Also the provision has been made to allow all zones within a controller to be set to the same value with a single command. i.e. CMD1 = 30 will affect all zones CMD1 = 31 will affect zone 1 CMD1 = 32 will affect zone 2 CMD1 = FF will affect zone 206

Echo

Table 30

Poll	20 20
Select	20 21
Format	Open 4 bytes ASCII
Units	ASCII
Poll Description	The SPI board will provide the retained data. If no data is selected after power on, the following is returned: NONE.
Select Description	The SPI board will retain the data provided.

Version

Table 31

Poll	20 22
Select	N/A
Format	Open 4 bytes ASCII
Units	ASCII
Poll Description	The SPI board will provide a version number: 03**. (** = 01 to FF)

Process Setpoint 1

Table 32

Poll	31 20
Select	30-31 21
Format	Numeric
Range	Limited temperature setting range of the E5AX (SLL to SLH)
Units	°F (or °C)
Poll Description	The SPI board will provide the temperature setpoint. If no data is selected after power on, temperature setpoint of the temperature controller board is returned.
Select Description	The SPI board will memorize the temperature setpoint and reply acknowledgement. Then the memorized temperature setpoint will be transferred into the temperature controller board. The SPI board will reply Command not executed; NAK while auto tuning.

Process Value

Table 33

Poll	31 22
Select	N/A
Format	Numeric
Units	°F (or °C)
Poll Description	The SPI board will provide process temperature from the temperature controller and memorize it into the SPI board. The process temperature will be provided to the SPI board independently from the communication between the SPI board and the control station. When the SPI board has no process temperature because of internal communication error, the SPI board will reply EOT.

Alarm Active Status

Table 34

Poll	31 2E
Select	N/A
Format	Status
Units	None
Poll Description	The SPI board will provide the status. Bit 0: Alarm Status Bits 1-15: 0

Alarm, Status

Table 35

Bit#	0
Description	There are active alarms in the control system
Description 0	No active alarms (VSD1 = 1, VSD2 = 1 and VSD3 = 1)
Description 1	Alarm active (1) VSD error VSD1 = 0, VSD2 = 0 and VSD3 = 0 VSD1 = 0, VSD2 = 0 and VSD3 = 1 VSD1 = 0, VSD2 = 1 and VSD3 = 0 VSD1 = 0, VSD2 = 1 and VSD3 = 1 VSD1 = 1, VSD2 = 0 and VSD3 = 0 VSD1 = 1, VSD2 = 0 and VSD3 = 1 VSD1 = 1, VSD2 = 1 and VSD3 = 0 (2) Heater burnout of E5AX (No power to heaters) (bit 0 of controller status) (3) The logical OR of the following alarm cases: Low alarm 1 of controller status High alarm 1 of controller status Low alarm 2 of controller status High alarm 2 of controller status (bits 3 to 6 of controller status) (4) Sensor failure, Overflow or Underflow The logical OR of open and shorted thermocouple alarms of controller status. (bits 7 and 9 of controller status) (5) A/D error (Process out of control)* (bit 15 of controller status) (6) Internal communication error

*A/D error does not include Memory error because the E5AX does not support Memory error on communication.
 (Active high mode: Logical 0 : Input ≤ 10 VAC, Logical 1 : Input ≥ 80 VAC)
 (Active low mode: Logical 0 : Input ≥ 80 VAC, Logical 1 : Input ≤ 10 VAC)

Alarm 1 Setpoint

Table 36

Poll	31 2C
Select	30-31 2D
Format	Numeric
Range	0 to 3000 (Thermocouple) 0.0 to 999.9 (Platinum resistance)
Units	°F (or °C)
Poll Description	The SPI board will provide the alarm 1 setpoint. If no data is selected after power on, the following is returned: 0.0.
Select Description	The SPI board will memorize and use alarm 1 setpoint independently from the temperature controller board.

Alarm 2 Setpoint

Table 37

Poll	31 32
Select	30-31 33
Format	Numeric
Range	0 to 3000 (Thermocouple) 0.0 to 999.9 (Platinum resistance)
Units	°F (or °C)
Poll Description	The SPI board will provide the alarm 2 setpoint. If no data is selected after power on, the following is returned: 0.0.
Select Description	The SPI board will memorize and use alarm 2 setpoint independently from the temperature controller board.

5-3 Software Errors

Other errors will occur due to the software's interpretation of its inputs.

Software Errors Due to Improper Setup

Machine Alarm

If a constant machine alarm is always received check that all 3 VSDs relative to common are logically high. Confirm if VSD inputs are set for active high or active low on pin 7 of the SPI board's SW1. Unused VSDs must be wired logically high.

Host Machine Assumes °F and °C Values Are Returned

If °C are returned to the control station and °F are desired, set the E5AX Function selector (SW 201) pin 5 to ON for °F display units.

Alarms Involving a Particular Command

Refer to *Appendix D Communication Protocol Specification* for the description of a particular command to confirm it is operating properly.

To turn off the alarm condition, the input causing the alarm must be returned to its proper operating condition.

DEVID 26h's latched alarms can be cleared using the appropriate alarm reset command.

Internal Communication Error

An internal communication error may occur under the following conditions:

- When the SPI board is selected for the following commands while the E5AX is autotuning.

Table 38

Setpoint process temperature	(20 31)
Alarm, high temperature deviation	(20 33)
Alarm, low temperature deviation	(20 35)
Process setpoint 1	(30-31 21)
Autotune proportional band 1	(30-31 47)
Autotune reset 1	(30-31 4B)
Autotune rate 1	(30-31 4F)
Heat cool ratio	(30-31 65)

- When the SPI board cannot communicate with the E5AX Temperature Controller board.

When a communication error occurs between the SPI board and the E5AX Temperature Controller board, the temperature alarm status bits will be turned OFF (be reset to 0).

(High Temperature Alarm, Low Temperature Alarm of Process status and Low alarm 1, High alarm 1, Low alarm 2 and High alarm 2 of controller status.)

Error Clearing

Internal communication errors may be cleared at the end of Auto-tuning and on returning to remote mode.

5-4 SPI Protocol Error Byte

The error byte (ERR) is defined by the SPI to communicate detected protocol errors. It has the following bit definitions:

Bit 7 (MSBit)	Invalid data
Bit 6	Reserved by SPI
Bit 5	Set to 1
Bit 4	Reserved by SPI
Bit 3	Command not supported

Bit 2	Command not executed
Bit 1	Invalid preamble
Bit 0 (LSBit)	Communication error
Invalid data	When this bit is set to 1 it means that the data received was received 'correctly', but that it was not appropriate for the command used. Reasons for this, for example, would be data out of range, too little data, too much data or an undetected CRCerror which produced erroneous data. This bit is set during the negative reply to any block where invalid data is detected.
Command not executed	When this bit is set to 1 it means that the command requested was not executed or no action was taken. Reasons for this, for example, would be that the controller has determined that executing the command would result in an unsafe condition within the selected auxiliary equipment, that the data was invalid, that the preamble was invalid or that there was a communication link error. This bit is set during the negative reply to a block which contains data that would prevent the command from being executed.
Invalid preamble	When this bit is set to 1 it means that the communication link experienced an error in its communication. This could result from a framing error, a CRC error being detected or a protocol violation. This bit is set during the negative reply to any block in which a communication error was detected.
Communication error	When this bit is set to 1 is means that the communication link experienced an error in its communication. This could result from a framing error, a CRC error being detected or a protocol violation. This bit is set during the negative reply to any block in which a communication error was detected.
Command not supported	When this bit is set to 1 it means that the requested command is not supported by the controller. Each auxiliary device will return this bit set in the ERR byte (possibly with other bits set such as Command Not Executed) when an unsupported command is received. If the ERR byte is returned with this bit set, the control station should retry the POLL or SELECTION to verify that the auxiliary device properly received the preamble data. This bit is set during the negative reply to any block which has an unsupported command.

See *Appendix F Communication Flowchart*, for the conditions that would enable and clear the above error bits.

APPENDICES

A Standard Models	63
B Hardware Specifications	65
C Dimensions	69
D Communication Protocol Specification	71
E Alarm Setting	79
F Communication Flowchart	83
G ASCII List	85

A Standard Models

Table 39

Name	Description	Part Number
E5AX Temperature Controller	Standard	E5AX-A03-SPI
	Heater burnout	E5AX-AH03-SPI
	Heating/cooling outputs	E5AX-VAA03-SPI
Communications Board	SPI Protocol (RS-485)	E53-X03-SPI
Control Output Unit	Relay output	E53-R
	SSR output	E53-S
	12 VDC (NPN) Voltage output	E53-Q
	24 VDC (NPN) Voltage output	E53-Q3
	24 VDC (PNP) Voltage output	E53-Q4
	Current output	E53-C
Current Transformers for Heater Burnout Detection E5AX-AH03-SPI	5.8 mm (0.23 in) hole diameter	E54-CT1
	12.0 mm (0.47 in) hole diameter	E54-CT3
Communications Connectors	9 pin D-sub plug	XM4A-0921
	9 pin D-sub hood	XM2S-0911

B Hardware Specifications

E5AX

Table 40

Supply voltage		100 to 240 VAC, 50/60 Hz	
Operating voltage		85 to 110% of rated supply voltage	
Power consumption		Approx. 10 VA at 100 VAC to 15 VA at 240 VAC	
Control output	Number	One output unit, ordered separately; mounts in internal socket of Standard E5AX-A, heater burnout E5AX-AH types. Two output units, ordered separately; mounts in internal sockets of heating/cooling E5AX-V output type.	
	Type	Relay	SPDT, 5 A, 250 VAC (resistive load) using E53-R output unit
		SSR	SPST-NO, 1 A, 75 to 250 VAC using E53-S output unit
	Voltage	40 mA, 12 VDC, NPN, using E53-Q output unit with short-circuit protection 20 mA, 24 VDC, NPN, using E53-Q3 output unit with short-circuit protection 20 mA, 24 VDC, PNP, using E53-Q4 output unit with short-circuit protection	
	Current	4 to 20 mA DC, 600 Ω max. load, 8-bit resolution using E53-C output unit. Current output unit cannot be used with heater burnout type E5AX-AH.	
	Isolation	All output units are optically isolated from the internal circuits	
	Hysteresis	0.0 to 999.9 °C/°F in units of 0.1 (during ON/OFF control action)	
Update time	Output	500 ms for pulse output	
	Display	500 ms	
Service life	100,000 electrical operations minimum for relay output unit E53-R 10 million mechanical operations minimum for relay output unit E53-R		
Alarm output	Number	One SPST-NO relay, 3 A, 250 VAC for E5AX-VA and E5AX-AH Two SPST-NO relays, 3 A, 250 VAC for E5AX-A	
	Setting range	Thermocouple: -999 to 9,999 °C/°F Platinum RTD: -99.9 to 999.9 °C/°F	
Heater burnout output E5AX-H only	Type	SPST-NO relay, 1 A, 250 VAC	
	Setting range	0.1 to 49.9 A in units of 0.1 A 0.0 setting disables the output 50.0 setting turns output ON continuously	
	Minimum detectable ON time	200 ms; heater current is not measured when the control output is ON less than 200 ms	
Indication accuracy	General	$\pm 0.3\%$ of set value or $\pm 1^\circ$, whichever is greater, ± 1 digit maximum	
	Exceptions	Accuracy of types T and U thermocouples is $\pm 2^\circ\text{C}$ (3.6°F) from -150° to 400°C (-240 to 700°F), ± 1 digit. Accuracy is not guaranteed below -150°C (-240°F). Accuracy of types R and S thermocouples is $\pm 3^\circ\text{C}$ ($\pm 5.4^\circ\text{F}$) from 0° to 200°C (32° to 400°F), ± 1 digit.	
	Heater burnout	$\pm 5\%$ of full scale, ± 1 digit maximum of heater current	
Setting accuracy		Set value coincides with the indicated value, since no relative error exists between both values	
Control modes	Type	ON/OFF or PID with automatic tuning and feed-forward circuitry to prevent overshoot	
	Proportional band	0.0 to 999.9 °C/°F in units of 0.1	
	Reset time	0 to 3,999 seconds in units of 1 second	
	Rate time	0 to 3,999 seconds in units of 1 second	
	Control period	Pulse output: 1 to 99 seconds in units of 1 second	
	Sampling period	500 ms	
Cooling coefficient		0.1 to 99.9 for model E5AX-V	
Dead band		-999 to 999 °C or °F (in 1 °C or °F units) for model E5AX-V	
Memory protection		Non-volatile memory (EEPROM)	

Other functions	Shift set input, E5AX-A, E5AX-VA	Sets a second set point. Requires no-voltage contact signal with input impedance of 100 Ω max. Thermocouple range: -999 to 9,999 °C/°F Platinum RTD range: -99.9 to 999.9 °C/°F
	Input shift, all models	Offsets input value and display value to accommodate a sensor input that deviates by a known value. Thermocouple range: -999 to 9,999 °C/°F Platinum RTD range: -99.9 to 999.9 °C/°F
	Miscellaneous, all models	Upper and lower set value limits, setting key disable, °C/°F selectable internally, Normal and Reverse output selection, DIN/JIS sensor input selection, Watchdog function to detect CPU failure and restore CPU to normal operation. Dead band and cooling coefficient for E5AX-V.
Indicators		Present Value, 15 mm H (0.59 in); Set Value, 11 mm H (0.43 in) LED digits; LED indicators for all functions
Materials		Plastic case
Mounting		Fits 1/4 DIN panel cutouts; includes two panel mounting brackets
Connections		Plated steel screw terminals mounted on rear of unit
Weight		Approx. 400 g (14 oz.)
Enclosure ratings	Front panel	IEC IP50
	Rear panel	IEC IP20
	Terminals	IEC IP00
Approvals	UL	Recognized, File Number E68481 (all models)
	CSA	Certified, File Number LR59623 (all models)
	Factory Mutual	Class Number 3545 (all E5AX-_-FMF models)
Ambient temperature	Operating	-10° to 55°C (14° to 131°F)
	Storage	-25° to 65°C (-13° to 149°F)
Humidity		35 to 85% RH
Insulation resistance		20 M Ω minimum at 500 VDC, measured with an output unit installed
Dielectric strength		2,000 VAC, 50/60 Hz for 1 minute between terminals of different polarity, measured with an output unit installed
Vibration	Mechanical durability	10 to 55 Hz, 0.75 mm (0.03 in) in X, Y, and Z directions for 2 hours each
	Malfunction durability	2 to 55 Hz, 2 G, in X, Y, and Z directions for 10 minutes each
Shock	Mechanical durability	300 m/s ² in 6 directions, 3 times each
	Malfunction durability	200 m/s ² in 6 directions, 3 times each

Current Transformers (for E5AX-H)

Table 41

Heater current	Maximum 50 A continuous service, single-phase
Weight	Approx. 11.5 g (0.41 oz.) for E54-CT1; approx. 50 g (1.8 oz.) for E54-CT3
Dielectric strength	1,000 VAC
Vibration	50 Hz (approx. 10 G)

VSD Inputs

Table 42

Maximum input voltage	132 VAC 50/60 Hz
High-level voltage	80 VAC min.
Low-level voltage	10 VAC max.
Input current	Approx. 1.3 mA
Plug in/out frequency	100 times max.
Wire stripping length	Approx. 6 mm
Tightening torque	0.5 N·m
Applicable wire size	AWG No.22 to 14
Active high/low	(Refer to Fig. 22 and Table 10.)
Connector type	SL4 12670.6 by Weidmueller Inc.
	BL4 12593.6 by Weidmueller Inc.

Standard Test Conditions

Table 43

Temperature	20°C
Humidity	65%

Note Unless otherwise specified, the values described in this specification were obtained under the above standard conditions.

Storage Conditions

Store the product under the following conditions.

Table 44

Temperature	-25 to 65°C (without freezing or condensation)
Humidity	35 to 85%

Storage Environment

- Locations where the product or container is not exposed to corrosive gases such as hydrogen sulfide gas or salty air.
- Locations where no visible dust exists.
- Locations not subject to direct sunlight.
- Do not apply stresses to the product which may result in its deformation or deterioration.

Operating Conditions

Use the product under the following conditions.

Table 45

Temperature	-10 to 55°C
Humidity	35 to 85%

Operating Environment

- Locations where the product is not exposed to dust or corrosive gas.
- Locations where the product is not subject to much vibration or shock and the product is not soaked in water or splashed with oil.
- Even if the temperature stays within the specified range, avoid using in locations where the temperature fluctuates greatly or where the product is exposed to the radiation from a furnace.
- Do not apply stresses to the product which may result in its deformation or deterioration.

C Dimensions

All units are in mm, unless otherwise specified.

E5AX Temperature Controller

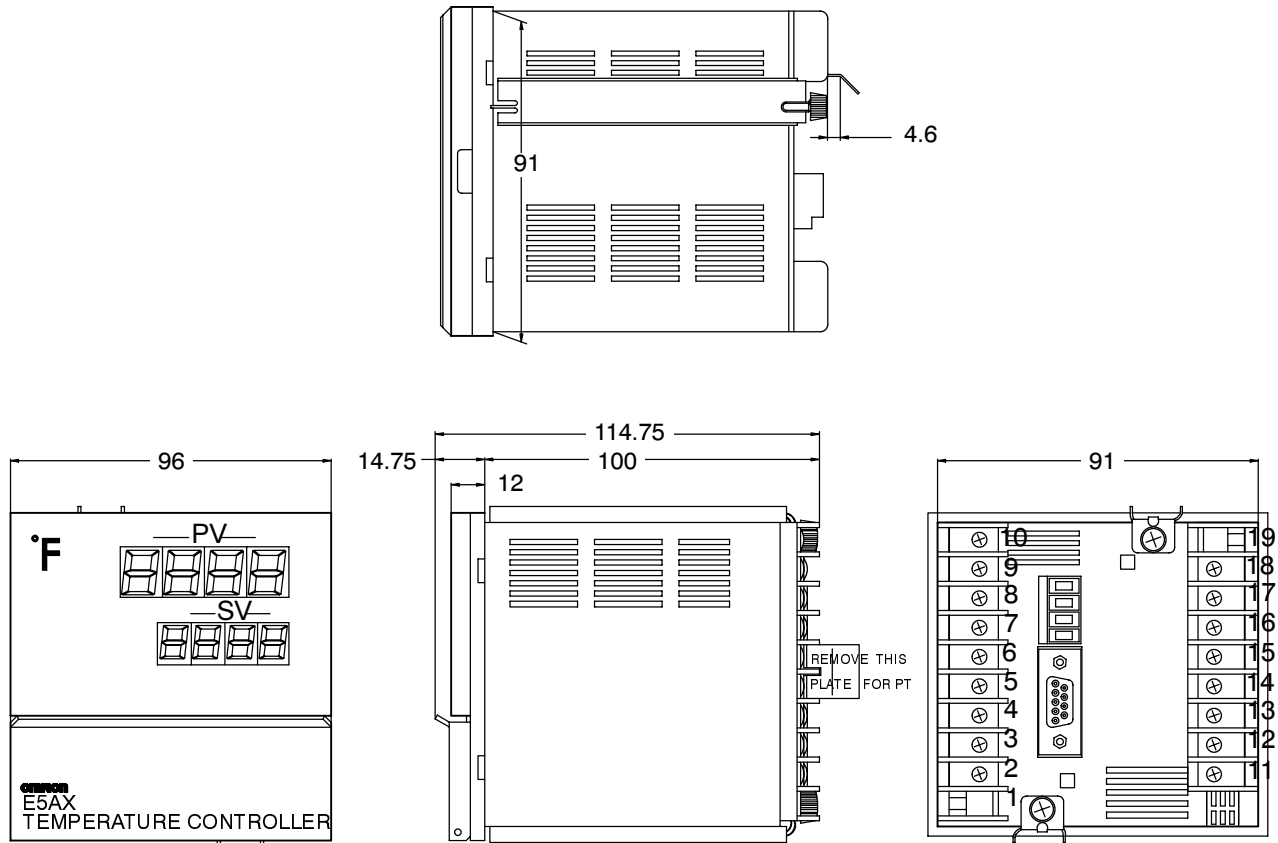

Fig. 55

Current Transformers (for E5AX-H)

E54-CT1

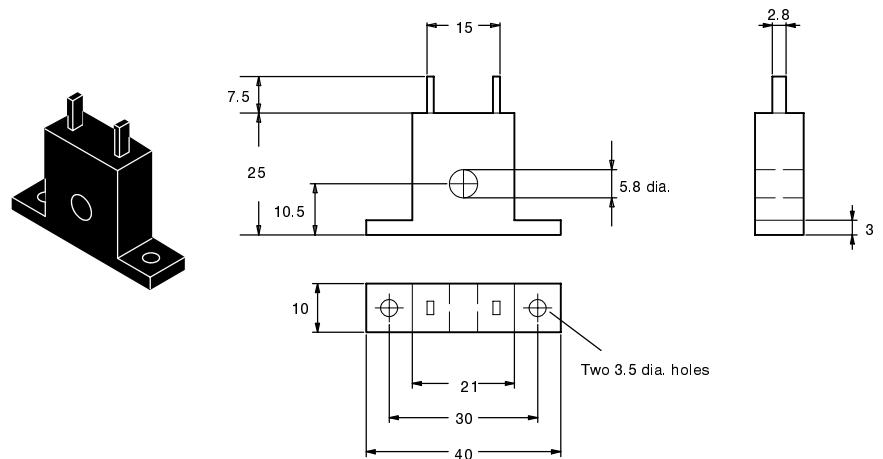

Fig. 56

E54-CT3

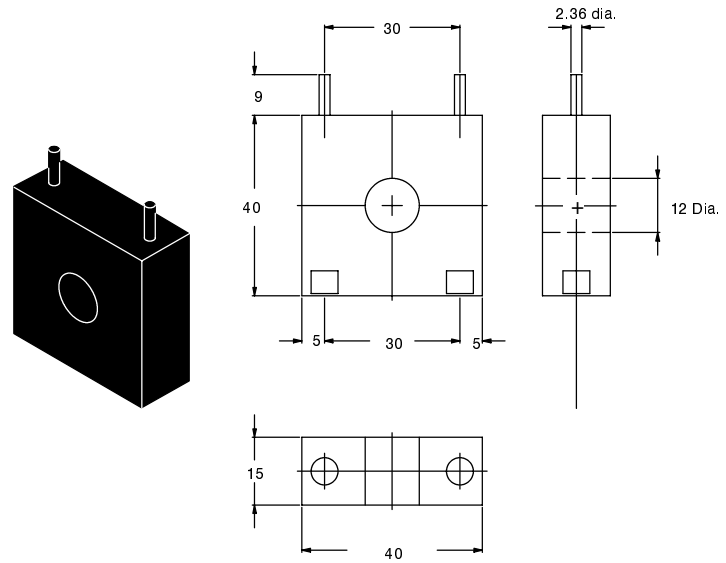

Fig. 57

Communications Connector

XM4A-0921 (Plug)

D-sub connectors. Use in combination with XM2S.

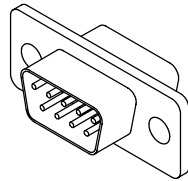

Fig. 58

XM2S-0911 (Hood)

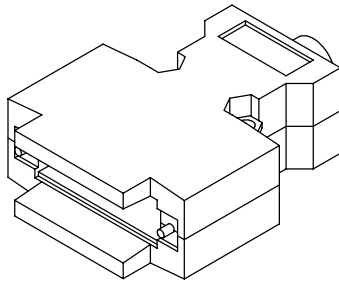

Fig. 59

D Communication Protocol Specification

Transmission Method

Table 46

Data communication link	Multipoint Link
Interface	RS-485
Maximum cable length	500m (1640 ft)
System limits	32 controllers per data link
Synchronization	Start-stop (1 stop bit)
Data rates	1200 to 19200 baud
Character Structure	ASCII 8 bits
Error detection	CRC-16
Definition	Tributary Station
Protocol	SPI Protocol

I/O List

The following DEVIDS, Polls, and Selects are in hexadecimal (h).

Mold Temperature Controller

Table 47

DEVID	20
Description	Water or Oil Temperature Controller

Echo

Table 48

Poll	20 20
Select	20 21
Format	Open 4 bytes ASCII
Units	ASCII
Poll Description	The SPI board will provide the retained data. If no data is selected after power on, the following is returned: NONE.
Select Description	The SPI board will retain the data provided.

Version

Table 49

Poll	20 22
Select	N/A
Format	Open 4 bytes ASCII
Units	ASCII
Poll Description	The SPI board will provide a version number: 03**. (** = 01 to FF)

Setpoint Process Temperature

Table 50

Poll	20 30
Select	20 31
Format	Numeric
Range	Limited temperature setting range of the E5AX (SLL to SLH)
Units	°F (or °C)
Poll Description	The SPI board will provide the temperature setpoint. If no data is selected after power on, temperature setpoint of the temperature controller board is returned.
Select Description	The SPI board will memorize the temperature setpoint and reply acknowledgement. Then the memorized temperature setpoint will be transferred into the temperature controller board. The SPI board will reply Command not executed; NAK while auto tuning.

Alarm 1 Reset

Table 51

Poll	N/A
Select	30-31 35
Format	Status
Units	None
Select Description	Bit 0: Alarm Clear Bits 1-15: 0

Note: If the SPI control station selects and sends 1's to bits 1 to 15, the SPI board will ignore these bits.

Alarm Clear

Table 52

Bit#	0
Description 0	No action
Description 1	Clears latched alarm conditions.

Note: When Alarm 1 is not selected for latching operation, this bit will have no effect.

Alarm 2 Reset

Table 53

Poll	N/A
Select	30-31 37
Format	Status
Units	None
Select Description	Bit 0: Alarm Clear Bits 1-15: 0

Note: If the SPI control station selects and send 1's to bits 1 to 15, the SPI board will ignore these bits.

Alarm Clear

Table 54

Bit#	0
Description 0	No action
Description 1	Clears latched alarm conditions.

Note: When Alarm 2 is not selected for latching operation, this bit will have no effect.

Alarm 1 Control

Table 55

Poll	31 38
Select	30-31 39
Format	Status

Units	None
Description	If no data is selected after power on, all 0's are returned. Bit 0: Low Hold Bit 1: Latching Bit 2: 0 Bit 3: Alarm Type Bit 4: Alarm Type Bit 5: Alarm Type Bits 6-15: 0

Note: If the SPI control station selects and sends 1's to bit 2 and bits 6 to 15, the SPI board will regard these bits as 0.

Table 56

Name	Bit #	Status	Description
Low hold	0		When alarm type is process low alarm, disable alarm until the process temperature exceeds the alarm setpoint the first time after power up or alarm 1's setpoint is changed. In other cases, disable alarm until the process temperature exceeds the alarm setpoint the first time after power up or alarm 1's setpoint or process setpoint 1 are changed.
		0	Disable low hold alarm function
		1	Enable low hold alarm function. (When alarm type is process high alarm or deviation high alarm, the low hold alarm function is disabled.) This is the same as OMRON's lower-limit alarm with standby sequence.
Latching	1		Latch alarm condition until explicitly cleared.
		0	Disable latching alarm.
		1	Enable latching alarm.
Alarm Type	3-5		This field selects the operation of the alarm. bit 5 4 3 0 0 0 : No Alarm 0 0 1 : Process low alarm 0 1 0 : Process high alarm 0 1 1 : Deviation low alarm 1 0 0 : Deviation high alarm 1 0 1 : Deviation band alarm 1 1 0 : No alarm 1 1 1 : No alarm

Note *Latching operation takes higher precedence than low hold operation.

Alarm 2 Control

Table 57

Poll	31 3C
Select	30-31 3D
Format	Status
Units	None
Description	If no data is selected after power on, all 0's are returned. Bit 0: Low Hold Bit 1: Latching Bit 2: 0 Bit 3: Alarm Type Bit 4: Alarm Type Bit 5: Alarm Type Bits 6-15: 0

Note: If the SPI control station selects and sends 1's to bit 2 and bits 6 to 15, the SPI board will regard these bits as 0.

See Alarm 1 control for bit descriptions.

Alarm Hysteresis

Table 58

Poll	31 42
Select	30-31 43
Format	Numeric
Range	0.0 to 999.9

Units	°F (or °C)
Poll Description	The SPI board will provide the alarm hysteresis. If no data is selected after power on, the following is returned: 0.2.
Select Description	The SPI board will memorize and use alarm hysteresis independently from the temperature controller board.

Controller Status

Table 59

Poll	31 44
Select	N/A
Format	Status
Units	None
Poll Description	Bit 0: Heater Power Bit 1: 0 Bit 2: 0 Bit 3: Low Alarm 1 Bit 4: High Alarm 1 Bit 5: Low Alarm 2 Bit 6: High Alarm 2 Bit 7: Open TC Alarm Bit 8: 0 Bit 9: Shorted TC Alarm Bit 10: 0 Bit 11: 0 Bit 12: 0 Bit 13: 0 Bit 14: 0 Bit 15: Process Out of Control

Table 60

Name	Bit #	Status	Description
Heater power	0		Indicates heater burnout of E5AX, when the temperature controller type is E5AX- _H.
		0	Heater burnout of E5AX
		1	No heater burnout of E5AX. In other temperature controller types, this bit is always 1.
Low alarm 1	3		If alarm 1 type is low alarm or band alarm, indicates that the temperature is below the alarm 1 setpoint.
		0	Alarm not active
		1	Alarm active
High alarm 1	4		If alarm 1 type is high alarm or band alarm, indicates that the temperature is above the alarm 1 setpoint.
		0	Alarm not active
		1	Alarm active
Low alarm 2	5		If alarm 2 type is low alarm or band alarm, indicates that the temperature is below the alarm 2 setpoint.
		0	Alarm not active
		1	Alarm active
High alarm 2	6		If alarm 2 type is high alarm or band alarm, indicates that the temperature is above the alarm 2 setpoint.
		0	Alarm not active
		1	Alarm active
Open TC alarm	7		Indicates sensor failure and overflow of the E5AX.
		0	No sensor failure and no overflow
		1	Sensor failure or overflow
Shorted TC alarm	9		Indicates sensor failure and underflow of the E5AX.
		0	No sensor failure and no underflow
		1	Sensor failure or underflow

Name	Bit #	Status	Description
Process out of control*	15		Indicates A/D error of the E5AX.
		0	No A/D error
		1	A/D error

*A/D error does not include Memory error because the E5AX does not support Memory error on communication.

Autotune Proportional Band 1

Table 61

Poll	31	46
Select	30-31	47
Format	Numeric	
Range	0.0 to 999.9	
Units	°F (or °C)	
Poll Description	The SPI board will provide the proportional band. If no data is selected after power on, the proportional band of the temperature controller board is returned.	
Select Description	The SPI board will memorize the proportional band and reply acknowledgement. Then the memorized proportional band will be transferred into the temperature controller board. The SPI board will reply Command not executed; NAK while auto tuning.	

Autotune Reset 1

Table 62

Poll	31	4A
Select	30-31	4B
Format	Numeric	
Range	0 to 3999	
Units	Seconds	
Poll Description	The SPI board will provide the reset time. If no data is selected after power on, the reset time of the temperature controller board is returned.	
Select Description	The SPI board will memorize the reset time and reply acknowledgement. Then the memorized reset time will be transferred into the temperature controller board. The SPI board will reply Command not executed; NAK while auto tuning.	

Autotune Rate 1

Table 63

Poll	31	4E
Select	30-31	4F
Format	Numeric	
Range	0 to 3999	
Units	Seconds	
Poll Description	The SPI board will provide the rate time. If no data is selected after power on, the rate time of the temperature controller board is returned.	
Select Description	The SPI board will memorize the rate time and reply acknowledgement. Then the memorized rate time will be transferred into the temperature controller board. The SPI board will reply Command not executed; NAK while auto tuning.	

Autotune Status

Table 64

Poll	31	52
Select	N/A	
Format	Status	

Units	None
Poll Description	Bit 0: Tuning in process Bit 1: No tuning Bit 2: 0 Bit 3: Full tuning Bits 4-15: 0

Table 65

Name	Bit #	Status	Description
Tuning in process	0	0	Not executing autotune
		1	Executing autotune
No tuning	1	0	Autotune is complete. (Using tuned parameters.)
		1	Using default parameters.
Full tuning	3	0	Not using tuned parameters. (Using default parameters.)
		1	Autotune is complete. (Using tuned parameters.)

Autotune Controls

Table 66

Poll	N/A
Select	30-31 55
Format	Status
Units	None
Poll Description	Bit 0: Autotune Bits 1-15: 0

Note: If the SPI control station selects and sends 1's to bits 1 to 15, the SPI board will ignore these bits.

Autotune

Table 67

Bit#	0
Description 0	No action
Description 1	Start tuning, when autotune is not already executing. This command becomes ineffective, when autotune is executing.

Note: When the E5AX is in ON/OFF control mode due to DIP switch settings, the SPI board should respond with Command not executed; NAK.

Heat Cool Ratio

Table 68

Poll	31 64
Select	30-31 65
Format	Numeric
Range	0.1 to 99.9
Units	Percent

Poll Description	The SPI board will provide the heat cool ratio when the temperature controller type is E5AX-V. In other cases, the following heat cool ratio is returned: 0.0. If no data is selected after power on, the heat cool ratio of the temperature controller board is returned.
Select Description	The SPI board will memorize the heat cool ratio and reply acknowledgement. Then the memorized heat cool ratio will be transferred into the temperature controller board. The SPI board will reply Command not executed; NAK while auto tuning. Other than with E5AX-V, the memorized heat cool ratio has no effect.

Specification Notes

Significant Digit

The E5AX numeric data is rounded off to the least significant digit (Thermocouple: 1 °F, Platinum resistance 0.1 °F).

Local Mode

SPI Communication should be off-line when the E5AX is in local mode. Changes made via the front panel during local mode, except for changes to alarm values, which can only be remotely changed on the SPI card, are updated to the SPI card on return to remote mode.

Temperature Units

The SPI board will not check the temperature unit spec (°C, °F) of the E5AX. SPI protocol assumes °F. This may be a problem if the host expects °F and the E5AX is set for °C.

Front Panel Key Invalidation

If the SPI control station continuously sends the following select commands, the E5AX front panel keys may become invalid and operation of the SPI board may be delayed.

Table 69

Setpoint process temperature	(20 31)
Alarm, high temperature deviation	(20 33)
Alarm, low temperature deviation	(20 35)
Process setpoint 1	(30-31 21)
Autotune proportional band 1	(30-31 47)
Autotune reset 1	(30-31 4B)
Autotune rate 1	(30-31 4F)
Heat cool ratio	(30-31 65)

Autotune Parameter Setting in ON/OFF Mode

The following commands can be read and written to when the E5AX DIP switch is in the ON/OFF control mode, although they have no effect on the E5AX operation.

- Autotune proportional band 1
- Autotune reset 1
- Autotune rate 1

E Alarm Setting

Alarm Operation

There are two kinds of alarms related to the E5AX with SPI protocol. The first alarm type is emulated through software communication with the SPI board. The second alarm type occurs within the E5AX itself and directly controls the alarm output relays.

DEVID 21h, 26h

DEVID 21 (h) (Chiller) and DEVID 26 (h) (Self-tuning general purpose TC) E5AX alarms are independent of the SPI protocol alarms and must be programmed from the keypad. The SPI protocol alarms must be programmed through the communication methods. The following explanations do not apply to these DEVID alarms.

DEVID 20h, 22h

Under certain conditions, DEVID 20 (h) (mold TC) and DEVID 22 (h) (dryer) SPI alarms set the E5AX relay alarm values. The E5AX alarm settings can also be used to enable the standby sequence function or to emulate SPI protocol alarms.

The following table shows how for DEVID 20 (h) and DEVID 22 (h), the SPI high and low temperature deviation alarm values, are used to set the E5AX's ALM1 and ALM2 values in addition to normally setting the SPI's high and low emulated alarm values.

Also shown is how the E5AX alarm mode setting affects the SPI emulated high and low alarms. When set to alarm mode 5, 6, 7, the SPI emulated alarms for DEVID 20 (h) and DEVID 22 (h) incorporate the standby sequence operation.

Refer to page 15 for a definition of the nine alarm modes.

Table 70

E5AX SW setting no.		SPI temperature deviation alarm commands set E5AX alarm values (ALM1/2) and SPI emulated alarms (H-EMU)						SPI ALARM operation based on the following conditions	
ALM1	ALM2	High temp dev. 20 33 command			Low temp dev. 20 35 command			Alarm, high temp.	Alarm, low temp.
0,4 or 9	0,4 or 9	H-EMU*	—	—	L-EMU*	—	—	H-EMU	L-EMU
1	0,4 or 9	H-EMU	ALM1***	—	L-EMU	—	—	H-EMU	L-EMU
2 or 8	0,4 or 9	H-EMU	ALM1	—	L-EMU	—	—	H-EMU	L-EMU
3	0,4 or 9	H-EMU	—	—	L-EMU	ALM1	—	H-EMU	L-EMU
5	0,4 or 9	H-EMU	ALM1	—	L-EMU	—	—	H-EMU***	L-EMU***
6	0,4 or 9	H-EMU	ALM1	—	L-EMU	—	—	H-EMU#	L-EMU
7	0,4 or 9	H-EMU	—	—	L-EMU	ALM1	—	H-EMU	L-EMU#
0,4 or 9	1	H-EMU	—	ALM2***	L-EMU	—	—	H-EMU	L-EMU
1	1	H-EMU	ALM1	ALM2	L-EMU	—	—	H-EMU	L-EMU
2 or 8	1	H-EMU	ALM1	ALM2	L-EMU	—	—	H-EMU	L-EMU
3	1	H-EMU	—	ALM2	L-EMU	ALM1	—	H-EMU	L-EMU
5	1	H-EMU	ALM1	ALM2	L-EMU	—	—	H-EMU#	L-EMU#
6	1	H-EMU	ALM1	ALM2	L-EMU	—	—	H-EMU#	L-EMU
7	1	H-EMU	—	ALM2	L-EMU	ALM1	—	H-EMU	L-EMU#
0,4 or 9	2 or 8	H-EMU	—	ALM2	L-EMU	—	—	H-EMU	L-EMU
1	2 or 8	H-EMU	ALM1	ALM2	L-EMU	—	—	H-EMU	L-EMU
2 or 8	2 or 8	H-EMU	ALM1	ALM2	L-EMU	—	—	H-EMU	L-EMU
3	2 or 8	H-EMU	—	ALM2	L-EMU	ALM1	—	H-EMU	L-EMU
5	2 or 8	H-EMU	ALM1	ALM2	L-EMU	—	—	H-EMU#	L-EMU#
6	2 or 8	H-EMU	ALM1	ALM2	L-EMU	—	—	H-EMU#	L-EMU
7	2 or 8	H-EMU	—	ALM2	L-EMU	ALM1	—	H-EMU	L-EMU#
0,4 or 9	3	H-EMU	—	—	L-EMU	—	ALM2	H-EMU	L-EMU
1	3	H-EMU	ALM1	—	L-EMU	—	ALM2	H-EMU	L-EMU
2 or 8	3	H-EMU	ALM1	—	L-EMU	—	ALM2	H-EMU	L-EMU
3	3	H-EMU	—	—	L-EMU	ALM1	ALM2	H-EMU	L-EMU
5	3	H-EMU	ALM1	—	L-EMU	—	ALM2	H-EMU#	L-EMU#
6	3	H-EMU	ALM1	—	L-EMU	—	ALM2	H-EMU#	L-EMU
7	3	H-EMU	—	—	L-EMU	ALM1	ALM2	H-EMU	L-EMU#
0,4 or 9	5	H-EMU	—	ALM2	L-EMU	—	—	H-EMU#	L-EMU#
1	5	H-EMU	ALM1	ALM2	L-EMU	—	—	H-EMU#	L-EMU#
2 or 8	5	H-EMU	ALM1	ALM2	L-EMU	—	—	H-EMU#	L-EMU#
3	5	H-EMU	—	ALM2	L-EMU	ALM1	—	H-EMU#	L-EMU#
5	5	H-EMU	ALM1	ALM2	L-EMU	—	—	H-EMU#	L-EMU#
6	5	H-EMU	ALM1	ALM2	L-EMU	—	—	H-EMU#	L-EMU#
7	5	H-EMU	—	ALM2	L-EMU	ALM1	—	H-EMU#	L-EMU#
0,4 or 9	6	H-EMU	—	ALM2	L-EMU	—	—	H-EMU#	L-EMU
1	6	H-EMU	ALM1	ALM2	L-EMU	—	—	H-EMU#	L-EMU
2 or 8	6	H-EMU	ALM1	ALM2	L-EMU	—	—	H-EMU#	L-EMU
3	6	H-EMU	—	ALM2	L-EMU	ALM1	—	H-EMU#	L-EMU
5	6	H-EMU	ALM1	ALM2	L-EMU	—	—	H-EMU#	L-EMU#
6	6	H-EMU	ALM1	ALM2	L-EMU	—	—	H-EMU#	L-EMU
7	6	H-EMU	—	ALM2	L-EMU	ALM1	—	H-EMU#	L-EMU#
0,4 or 9	7	H-EMU	—	—	L-EMU	—	ALM2	H-EMU	L-EMU#
1	7	H-EMU	ALM1	—	L-EMU	—	ALM2	H-EMU	L-EMU#
2 or 8	7	H-EMU	ALM1	—	L-EMU	—	ALM2	H-EMU	L-EMU#
3	7	H-EMU	—	—	L-EMU	ALM1	ALM2	H-EMU	L-EMU#
5	7	H-EMU	ALM1	—	L-EMU	—	ALM2	H-EMU#	L-EMU#

E5AX SW setting no.		SPI temperature deviation alarm commands set E5AX alarm values (ALM1/2) and SPI emulated alarms (H-EMU)						SPI ALARM operation based on the following conditions	
ALM1	ALM2	High temp dev. 20 33 command			Low temp dev. 20 35 command			Alarm, high temp.	Alarm, low temp.
6	7	H-EMU	ALM1	—	L-EMU	—	ALM2	H-EMU#	L-EMU#
7	7	H-EMU	—	—	L-EMU	ALM1	ALM2	H-EMU	L-EMU#

*H-EMU = Emulated high temperature alarm of SPI protocol

L-EMU = Emulated low temperature alarm of SPI protocol

**H-EMU# = Emulated high temperature alarm of SPI protocol with power on standby sequence

L-EMU# = Emulated low temperature alarm of SPI protocol with power on standby sequence

***ALM1 = Alarm 1 of the E5AX; ALM2 = Alarm 2 of the E5AX

ALM1 = 0 applies to E5AX-AH03-SPI and E5AX-VAA03-SPI since only ALM2 is available with these models.

When E5AX alarm type is set to 8 (event output), the following conditions additionally apply:

- '20 33 command set value' is added to 'temperature set value' and set on the E5AX.
- When a platinum resistance thermometer is used for the E5AX sensor, '20 33 command set value' is added to 'temperature set value' and checked if it is within the range from -99.9 to 999.9 .
- When the process temperature value is changed, the E5AX alarm value will not be changed.

F Communication Flowchart

SPI Communication Protocol Tributary Behavior: Polling

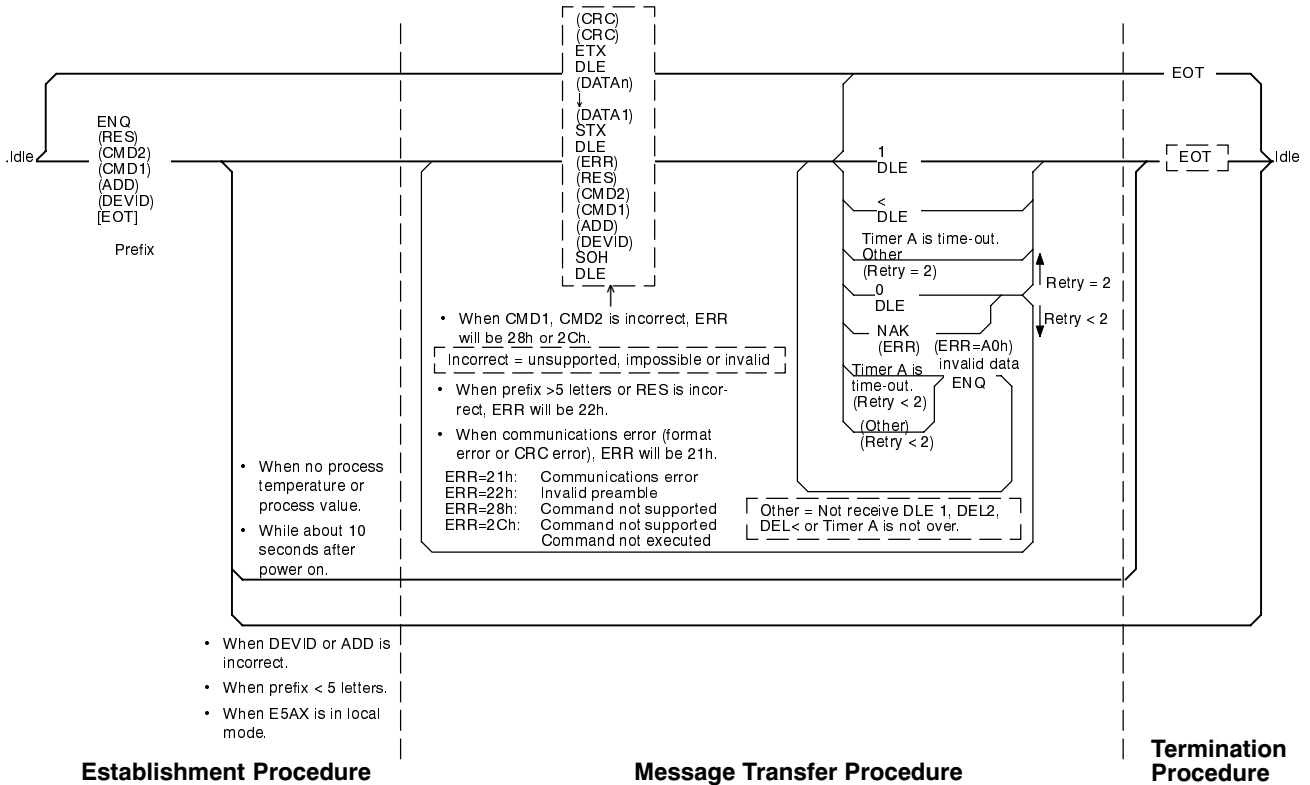
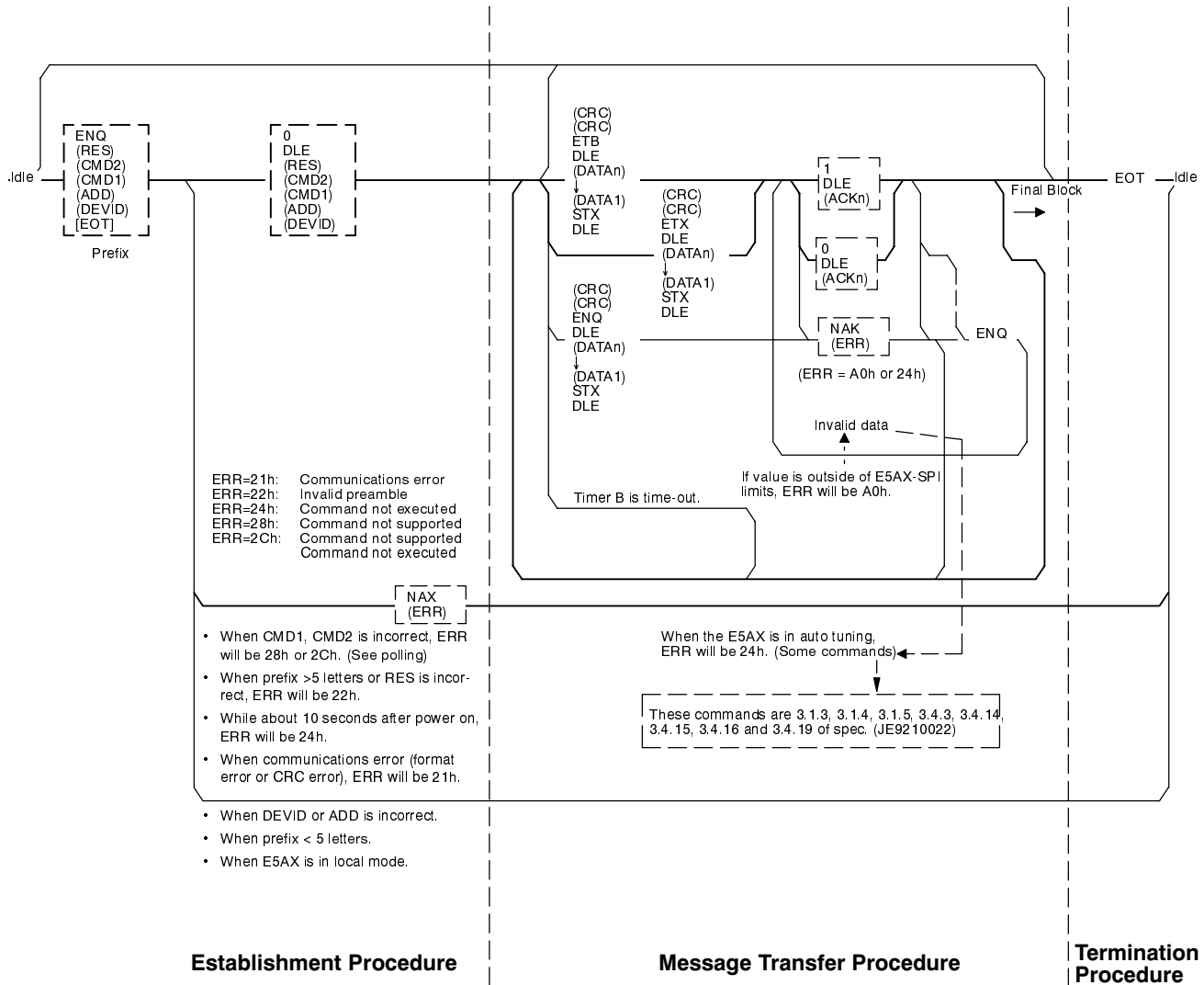

Fig. 60

SPI Communication Protocol Tributary Behavior: Selecting



Note: [---] = send Other = receive

Note: Timing requirements are not shown. Refer to SPI Protocol v. 3.01 or its supporting standards for a more detailed explanation.

Fig. 61

Supporting Standards of SPI Communication Protocol

- EIA 485
- EIA 404
- ANSI X3.4-1977
- ANSI X3.16-1976
- ANSI -1976
- ANSI X3.28-1976, subcategories D1 and 2.4
- IEEE 8300-1984
- IEEE 754-1985
- MIL-C-26482

G ASCII List

Table 71

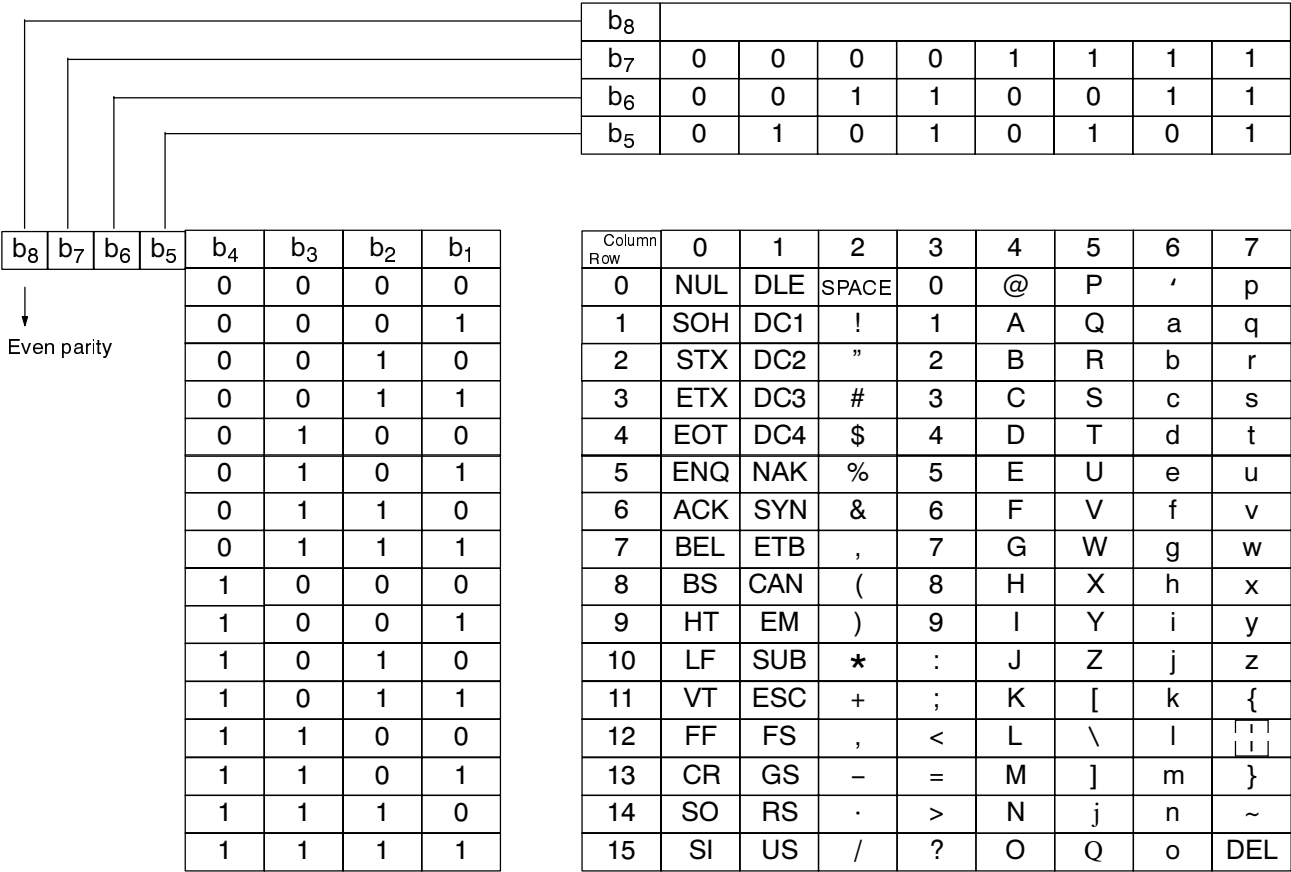

Glossary

Abort	When the sending station desires to end a block or transmission in an unusual manner such that the receiving station disregards that portion of the block or transmission that has been received.
ACKN	Acknowledge N: ACKN is represented by the <10><30> for ACK0 and <10><31> for ACK1 control sequences. The ACKN is used by a receiver as an affirmative reply. ACK1 is used as an affirmative reply to the first block of a message, and affirmative replies to subsequent blocks alternate between ACK0 and ACK1. ACK0 is also used as the reply from a tributary to the control station in response to a SELECT supervisory request.
Acknowledgment	Used as a reply to a master station that a valid message has been received and accepted. There are two valid alternating acknowledgment character sequences, DLC '0' (ACK0) and DLE '1' (ACK1). ACK1 is used as the acknowledgment for the first transmission block received, and the acknowledgment is alternated between ACK0 and ACK1 on subsequent blocks. ACK0 is also used as the acknowledgment by a tributary to the control station's SELECT request supervisory sequence.
ADD	ADDRESS: an 8-bit quantity used during the connection establishment procedures to identify a particular tributary station. Used in conjunction with the DEVID. The actual address values are selectable at the tributary stations.
Alternating Transmission	A type of transmission through which messages or transmission blocks may be sent in either one direction or the other, but not both directions simultaneously.
ANSI	American National Standards Institute: The main standards development group in the USA. ANSI is a non-profit non-government group composed of over 1000 trade organizations, professional societies, and companies. It is the USA' member body to ISO.
ASCII	American National Standard Code for Information Interchange: Specifies a set of 128 control and data characters defined as a standard data communications code in American Standard Code for Information Exchange. Each character is specified in seven binary bits, with the first 32 characters representing control and special action characters. See the ASCII chart following this glossary.
Baud	A unit of signaling speed, the number of signal events per second. If each signal event represents only one bit condition, the baud is equal to bits per second.
Bit	Binary digit: the smallest unit of information in a binary system. A bit represents a choice between 1 and 0.
Block Abort (DLE ENQ)	The sending station, while sending data, but before the end of the block, decides to end the block. The receiving station will disregard all data received for that block. Both stations will return to non-transparent mode. The NAK response is the only valid response to the aborted block.
Centralized Operation	A control discipline for multipoint data communications links by which transmission may occur between the control station and any one of the tributary stations, but not between tributary stations themselves.

CMD1	CoMmanD1: an 8-bit quantity used during the connection establishment procedures to specify the most significant command byte. Used in conjunction with CMD2 to specify a particular action to be taken or data to be communicated.
CMD2	CoMmanD2: an 8-bit quantity used during the connection establishment procedures to specify the least significant command byte. Used in conjunction with CMD1 to specify a particular action to be taken or data to be communicated. an even CMD2 (least significant bit is reset) indicates a POLL request. An odd CMD2 (least significant bit is set) indicates a SELECT request.
Communications Facility	The actual medium used to provide communication circuits. Some examples may be wire cable, radio, fiber optics.
Communications Circuit	A means of two-way communication between two circuit points.
Contention	Occurs when two or more stations attempt a transmission at the same time.
Control Character	A functional ASCII character intended to control Control Character or facilitate transmission of information over communication networks. There are ten control characters defined by ASCII which will be used in this protocol: EOT, SOH, STX, ETX, ACK, NAK, ENQ, ETB, SYN, DLE.
Control Station	The station on a data communications link with the overall responsibility for monitoring the communications link and assuring the link's orderly operation. The control station has the responsibility for initiating recovery procedures in the event of abnormal conditions on the link.
CRC-16	Cyclic Redundancy Check 16: An error detection scheme designating the bits added to the end of a message or transmission block to facilitate error control. The '16' specifies use of a degree-16 polynomial generator.
Daisy Chain	A multi-drop wiring technique where all network members are on the same cable.
Data Link	The logical association of two or more stations interconnected by the same data communication circuit, including the communication control capability of the interconnected stations.
Data Integrity	A performance measure based on the rate of undetected errors.
DLE	Data Link Escape <10H>: the DLE character is used to change the meaning of the character. It is used exclusively for providing additional control functions. It is used in the following control functions: <ul style="list-style-type: none">• Alternating Acknowledgments.• Transparent block delimiting sequences (TSOH, TSTX, TETX, and TETB).• Transparent DLE (a DLE, <10>, character in a transparent text sequence is represented by DLE DLE).• The block abort function.• The reverse interrupt function.• The synchronous idle function.
Delimiters	Control characters used to define the extent of a particular sequence of characters (for example delimiting the entry and exit of transparent data mode).

DEVID	DEVIce IDentifier: an 8-bit quantity used during the connection establishment procedures to identify a particular tributary station device type. Used in conjunction with the ADD. The actual values of the DEVID are assigned by the SPI/CCP.
DIP Switch	A bank of switches in a Dual In-line Package used to field-configure hardware.
EIA	Electronic Industries Association: A standards organization specializing in electrical interfacing.
ENQ	ENQuiry <05>: the ENQ character is used to illicit a response from a station. The ENQ calls for a reply indicating the slave station's readiness to receive. The ENQ character is also used as the last character in a polling or selection sequence. Receipt of the ENQ character by a slave station calls for the slave station to re-transmit its last reply (ACK0, NAK, etc.).
EOT	End Of Transmission <04>: the EOT character performs the following functions: <ul style="list-style-type: none">• Cancels any previous master/slave relationship• Sent by the master station after completion of a message transfer phase to normally end a transmission.• Sent by the master station prior to completing the message transfer phase to cause a sending station abort.• Sent by the slave station in place of a normal response to cause a termination interrupt.• The EOT character must never have a prefix.
ERR	ERRor byte: an 8-bit quantity used as a prefix for negative acknowledgments to indicate why the acknowledgment was negative.
Half Duplex	Transmission in either direction, but not both directions simultaneously.
Hex	Hexadecimal numbering system represented by an h following the number.
Host	Master/control station supporting the E5AX through the SPI Protocol.
Interrupt	When a receiving station wishes to cause the sending station to stop sending, either temporarily or permanently.
ISO	International Standards Organization
mS	Milliseconds, 1/1000 of a second.
Mark	Presence of a signal. A mark impulse is equivalent to a set (1) bit.
Master Station	A station that has control of the data communication link at a given instant. The assignment of master status to a given station is temporary and is controlled by the procedures set forth in the categories described in this standard. Master status is normally conferred upon a station so that it may transmit a message, but a station need not have a message to send to be nominated master.
Message	A sequence of characters arranged for the purpose of conveying information from an originator to one destination (or address). It contains the supplementary information in a heading.

Message Heading	The part of a message containing all components preceding the text. A message heading is preceded by the TSOH sequence and followed by the TSTX sequence (delimited by TSOH and TSTX).
Message Text	The part of a message beginning with the first character following the TSTX sequence and followed by the TETX sequence.
Multipoint Link	A data communication link connecting two or more stations.
NAK	Negative-Acknowledgment <15>: the NAK character is transmitted by a slave as a negative response to a sending station. The NAK may contain a prefix indicating why the message or transmission block was rejected. The NAK performs the following functions: <ul style="list-style-type: none">• NAK indicates that the selected station is not ready to receive.• Is transmitted by a slave to indicate that the last message or transmission block was not accepted and the slave is again ready to receive. A prefix will be included indicating why the transmission was rejected.
Network Bus	The physical bus media which extends from the primary plastic processing machine. All tributary stations connect to the bus via Unit Stubs.
<nn>	nn is a hexadecimal constant.
Polling	A technique for inviting a station to transmit messages at a given time. One station is designated as a control station to invite tributary station(s) to transmit. A supervisory sequence performs this polling function.
Prefix	A sequence of characters (other than communications control characters) used in a supervisory sequence to define or qualify the meaning of the supervisory sequence.
Protocol	A formal set of conventions governing the format and relative timing of data exchange between two or more communicating systems.
Recovery Procedure	Control procedures used to restore normal operation to a data communication link after unusual or abnormal events have occurred.
Reply	A supervisory sequence by which a slave station informs the master station of its operational condition or status, or the status of a received message or message block.
Reply-Request	A supervisory sequence used by a master station to request a reply from a slave station.
RES	Reserved Character: a character reserved for later definition by SPI. At this time the character must be <20>.
RS-485	EIA computer communications standards established for uniform signal specifications.
Responder	The station that is responsible for supplying reply messages to the initiator.
Reverse Interrupt	The control station, while acting as a receiving station, may decide to interrupt the current communication session to poll or select another station. The station may only generate a reverse interrupt (DLE <3C>) after receipt of a valid CRC. The reverse interrupt is assumed by the sending station to be a valid acknowledgment to the transmitted block. The sending station should then transmit an EOT to abort the communication session as soon as it can without losing any data it may have stored in buffers. It then must be able to receive a transmission.

Selection	A technique for assignment of slave status to a station on a data communication link. A supervisory sequence performs the selection function.
Sending Station Abort (EOT)	The sending station, after completing a transmission block (DLE ETB or DLE ENQ), and after receipt of a valid response (ACK0, NAK, etc.) or Timer A time-out, prematurely terminates the transmission to the receiving station by transmitting an EOT. The transmission of the EOT resets all stations on the communication link, and returns all stations to the non-transparent control mode.
Slave Station	A station that has been selected to receive a transmission from the master station. The assignment of slave status is temporary, under control of the master station, and continuous for the duration of a transmission.
Space	Absence of a signal, used to indicate a reset (0) binary condition.
SPI	Society of Plastics Industry: A professional society consisting of representatives of companies involved in all aspects of the plastics industry.
SPI Board	The E53-X03-SPI, SPI Protocol Communication Unit.
Station	The independently controllable configuration of Station logical elements, from or to which messages are transmitted on a data communication link. It includes those elements (data communication equipment, intermediate terminal equipment) that control the message flow on the link via data communication control procedures.
Station Identification	A sequence of characters used to identify a particular station.
Start Bit	The first bit in each character, normally a space, which causes the receiving equipment to prepare for the reception of a character.
Stop Bit	The last bit or element in each character, normally a mark, to which is assigned a minimum duration, during which the receiving equipment is returned to its rest condition in preparation for the reception of the next character.
Supervisory Sequence	A sequence of communication control characters and possibly other characters that performs a defined control function. A supervisory sequence may contain a prefix together with any required delimiters.
SYN	Synchronous Idle Sequence (DLE SYN): used as a time-fill sequence when a sending station is unable to send its normal data. The SYN sequence may be added at any time during the transmission except: <ul style="list-style-type: none">• In a DLE sequence.• Between DLE ETB or DLE ETX and the following CRC characters.
Termination Interrupt (EOT)	The receiving station, deciding that it is (EOT) unable to continue to receive data, transmits an EOT instead of one of the normal responses (ACK0, NAK, etc.). This transmission indicates a non-acknowledgment of the data block, resets all stations on the communication link, and returns all stations to the non-transparent control mode.
Timer A	ANSI x3.28 response timer. Used by the sending station to protect against an invalid response or no response. Timer A is started after transmitting any ending character where a response is expected (such as ENQ, TETB, or TETX). Timer A is stopped by receipt of an entire valid reply (such as ACK0, NAK, etc.). Timer A is never restarted. A recovery procedure is to be executed if Timer A times-out.

Timer B	ANSI x3.28 receive timer. Used by a receiving station to protect against non-recognition of TETB or TETX sequences. Timer B is started upon receipt of the start of block or text (TSOH or TSTX) Timer B may be restarted upon receipt of characters. Timer B is stopped by receipt of a valid terminating character or character sequence (such as TETX, TETB, ENQ, etc.). A recovery procedure is to be executed if Timer B times-out.
Timer D	ANSI x3.28 non-activity timer. Used by all stations on the communication link to determine no activity on the link. Timer D is started or restarted upon receipt of any character. Timer D is stopped upon receipt or transmission of EOT. A recovery procedure is to be executed if Timer D times-out.
Timer E	Used by a device to wait after the last character has been transmitted before the device begins its own data transmission. The timer is started when a receiver detects the last character has been transmitted by a sending device. The timer is never restarted or stopped. Time-out of Timer E indicates that the waiting device is now able to begin transmission.
Time-Out	Occurs when one of the ANSI timers (A, B, or D) counts down to zero before being stopped or reset.
Transmission	The entirety of the data transmitted between the master station and slave station for the period of their uninterrupted assignment of such status.
Transmission Block	A group of characters transmitted as a unit. A transmission block may contain a message, a portion of a message, or combinations thereof.
Transparent Data	Allows the transmission of all 8-bit codes as data in the text part of a message.
Tributary Station	A station on a data communication link that is not the control station.
TSOH	Transparent Start of Header (DLE SOH): used at the beginning of a sequence of characters that constitutes a machine address or routing information. The TSTX sequence terminates the header.
TSTX	Transparent Start of Text (DLE STX): this control sequence is used to indicate the start of transparent text. It also serves to terminate a transparent header sequence if one precedes it. The TSTX places the data link in a condition to process transparent data. If a message consists of multiple transmission blocks, the TSTX sequence is used to start all subsequent blocks.
TETB	Transparent End of Block (DLE ETB): the TETB sequence is used to terminate a block of transparent data that is not the last block of the message. It signals that the next two following characters are the CRC characters and that the slave should transmit a reply. TETB returns the data link to a non-transparent condition.
TETX	Transparent End of Text (DLE ETX): the TETX control sequence indicates the end of a transparent message. It signals the slave device that the next two following characters are the CRC characters and that the slave is expected to transmit a reply. This sequence is used to terminate the last block of a message and causes the data link to return to a non-transparent condition.

Glossary

Unit Load	A hypothetical quantity representing the DC loading that passive generators and receivers place on the communication circuit. You must examine the hardware specifications for your communication chip(s) set to define the unit loading produced by your transceiver.
Unit Stub	The physical media used to connect a tributary station to the network bus.

Index

Symbols

----, 52

A

A/D error, 52
abort, 87
ACKN, 87
acknowledgment, 87
active alarm status, 36
active high/low, switch setting, 19
ADD, 87
address, 3
 switch setting, 20
advanced PID control, 14
alarm
 high temperature, 35
 low temperature, 35
 machine, 35
 process, 35
 system, 35
alarm 1 mode, 44
 switch location, 12
alarm 1/2 control, 36
alarm 1/2 reset, 36
alarm 1/2 setpoints, 36
alarm 2 mode, 44
 switch location, 12
alarm active status, 56
alarm clear, 72
alarm control, 72
alarm hysteresis, 36, 73
alarm mode selection, 15
alarm operation, 79
alarm output 1 indicator, 6
alarm output 2 indicator, 6
alarm reset, 72
alarm setpoint, 57
alarm type, 73
alarm, high temperature deviation, 3, 34
alarm, low temperature deviation, 3, 34

alternating transmission, 87
analog-to-digital converter failure, 52
ANSI, 87
ASCII, 87
ASCII table, 85
auto-tuning key, 6
automatic tuning, PID, 48
autotune, 76
autotune controls, 36
autotune proportional band, 36
autotune rate, 36
autotune reset, 36
autotune status, 36
auto-tuning indicator, 6

B

back panel, 7
backup mode, 19
baud, 87
bit, 87
block abort, 87

C

centralized operation, 87
checking data receipt, 52
checking data transmission, 52
chiller, 55
circuit
 feed inverting, 7
 feed non-inverting, 7
 return inverting, 7
 return non-inverting, 7
CMD1, 88
CMD2, 88
command not executed, 59
command not supported, 59
communication facility, 88
communication circuit, 88
communication error, 59
communication flowchart, 83

communications connector, 7, 26, 70
Connector, 63
connector, communications, 7
contention, 88
control character, 88
control mode, switch setting, 13
control output variable, 43
control period, 41, 48
control station, 2, 88
Controller status, 36, 74
cooling coefficient, 47
CRC-16, 88
CURRENT, switch location, 12
Current Transformers, 63
current transformers, 66, 69

D

daisy chain, 88
daisy chain connections, 8
data integrity, 88
data link, 88
dead band, 47
debugging communication failure, 52
delimiters, 88
device identifier, 3
DEVID, 3, 89
DEVID 20h, 22h, 79
DEVID 21h, 26h, 79
dimensions, panel cutout, 26
DIP switch, 89
direct programming, 36
display
 process value, 6
 set value, 6
display units, switch setting, 13
DLE, 88
down key, 6
dryer, 55

E

E111, 52

E333, 52
E5AX-A03-SPI, wiring, 24
E5AX-AH03-SPI, wiring, 24
E5AX-VAA03-SPI, wiring, 25
echo, 3, 34
EIA, 89
ENQ, 89
EOT, 89
ERR, 89
error clearing, 58
error messages, 52
errors, software, 58
establishing communication, 52
establishment procedure, 84

F

factory settings, 13
feed inverting circuit, 7
feed non-inverting circuit, 7
feed-forward, 14
FFFF, 52
format, 74
front panel, 6, 52
front panel key invalidation, 77
full tuning, 76
function selector, switch location, 12

G

ground
 shield, 7
 signal, 7

H

half duplex, 89
hardware specifications, 65
heat cool ratio, 36, 76
heater burnout, 45
heater power, 74
high alarm, 74
host, 89
hysteresis value, 41

I

indicator
 alarm output 1, 6
 alarm output 2, 6
 auto-tuning, 6
 output, 6
 remote operation, 6
 shift, 6

input, VSD, 8

input shift, setting, 39

input shift data display, switch setting, 13

interface, RS-485, 7

internal communication error, 58

internal mechanism, removing, 10

internal switches, 9

interrupt, 89

invalid data, 59

invalid preamble, 59

ISO, 89

K

key
 auto-tuning, 6
 down, 6
 level, 6
 mode, 6
 remote, 6

key protection, 14

key up, 6

L

latching, 73

level 0, 45

level 1, 45

level 2, 46

level key, 6

local mode, 7, 77

locations of internal switches, 11

low alarm, 74

low hold, 73

M

mark, 89

master station, 2, 89

memory failure, 52

message, 89

message heading, 90

message text, 90

message transfer procedure, 84

mode key, 6

mold temperature controller, 71

mounting, 26

mounting brackets, 27

mounting output unit, 10

mS, 89

multipoint link, 90

N

NAK, 59, 90

negative alarm values, 16

network bus, 90

nn, 90

no tuning, 76

O

open thermocouple alarm, 74

operating conditions, 67

output indicator, 6

output operation, switch setting, 13

output selector, switch location, 12

output selector (cooling), switch location, 12

output selectors, 15

overflow, 52

overshoot, 14

P

panel cutout, 26

PID, automatic tuning, 48

PID constant data display, switch setting, 13

Poll, 2

polling, 83, 90

prefix, 90
process out of control, 74
process setpoint 1, 56
process value, 36, 56
process value display, 6
processing, 35
programming the E5AX, 33
proportional alarm, 16
protocol, 90
PULSE, switch location, 12

R

RAM write mode, 20
range, 73
RE-485, 90
re-connecting components, 21
recovery procedure, 90
Relay Output Unit, 63
remote key, 6
remote mode, 6
remote operation indicator, 6
remote programming, 33
removing external cables, 9
removing internal mechanism, 10
removing output unit, 10
removing SPI board, 10
reply, 90
reply-request, 90
RES, 90
responder, 90
return inverting circuit, 7
return non-inverting circuit, 7
reverse interrupt, 90
RS-485 interface, 7

S

Select, 2
selecting, 84
selection, 91
self-recalibration, 49

Self-tuning general purpose temperature controller, 55
sending station abort, 91
sensor, connection, 28
sensor failure, 57
SErr, 52
set value display, 6
setpoint process temperature, 3, 34
setting SPI switches, 18
setting the E5AX controller, 32
shield ground, 7
shift indicator, 6
shift set value, 41
shorted thermocouple alarm, 74
signal ground, 7
significant digit, 77
slave station, 2, 91
software commands, 3
software errors, 58
space, 91
SPI, 2, 91
SPI board, 91
SPI Protocol, 2
SSR Output Unit, 63
standard test conditions, 67
standby sequence, 16
start bit, 91
station, 91
station identification, 91
status, process, 3, 35
stickers, 29
stop bit, 91
storage conditions, 67
supervisory sequence, 91
switch settings, 13
switches, internal, 9
SYN, 91
system configuration, 2

T

temperature sensor, connection, 28
temperature sensor standard, switch setting, 13

temperature units, 77
temperature, to process, 3, 35
terminal, VSD input, 8
terminal connections, 24, 28
terminal layout diagram, 29
termination interrupt, 91
termination procedure, 84
terminator, switch setting, 20
TETB, 92
TETX, 92
time-out, 92
Timer A, 91
Timer B, 92
Timer D, 92
Timer E, 92
transmission, 92
transmission block, 92
transparent data, 92
tributary station, 2, 92
TSOH, 92
TSTX, 92

tuning in process, 76

U

underflow, 52
unit load, 93
unit stub, 93
units, 73
up key, 6

V

version, 3, 34
Voltage Output Unit, 63
VSD, 2
VSD input, 8
VSD inputs, 66

W

wiring, 24
write mode, switch setting, 19



OMRON ELECTRONICS LLC

1 Commerce Drive
Schaumburg, IL 60173
847.843.7900
For US technical support or
other inquiries: 800.556.6766

OMRON CANADA, INC.

885 Milner Avenue
Toronto, Ontario M1B 5V8
416.286.6465

OMRON ON-LINE

Global - <http://www.omron.com>
USA - <http://www.omron.com/oei>
Canada - <http://www.omron.ca>

UNITED STATES

To locate a Regional Sales Office, local Distributor or
to obtain product information, call: 847.843.7900

CANADA REGIONAL SALES OFFICES

Ontario	Toronto	416.286.6465
	Kitchener	519.896.1144
	Kingston	613.376.3968
Quebec	Montreal	514.636.6676
British Columbia	Vancouver	604.522.8855
Alberta	Edmonton	403.440.0818
	Calgary	403.257.3095

BRAZIL SALES OFFICE

Sao Paulo 55.11.5564.6488

ARGENTINA SALES OFFICE

Cono Sur 54.114.787.1129

MEXICO SALES OFFICES

Florida 954.227.2121 **Ciudad Juarez** 656.623.7083
Mexico, D.F. 555.534.1195 **Monterrey, N.L.** 818.377.4281