

Multiple-Rotation Absolute Encoder

E6C-M

Compact, Multiple-Rotation Absolute Rotary Encoder Reduces the Size of Required Equipment

- Data is retained and rotational measurement continues even after power is interrupted
- High-resolution 23-bit sensing in a compact package (60 mm long × 50 mm in diameter)
- Drip-proof, oil-proof construction meets IP64F standards
- Wiring is reduced through serial transfer of position signals
- Receiver Unit converts the serial signal to a parallel signal

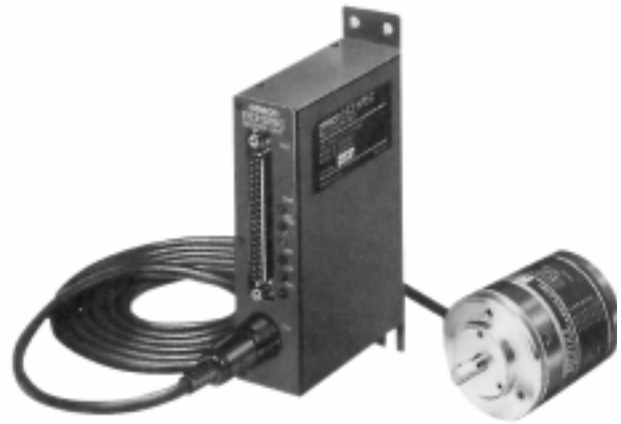

Ordering Information

| Name | Part Number |
|------------------------------------|------------------------------|
| Multiple-rotation Absolute Encoder | E6C-MPZ1X2 (see note) |
| Receiver Unit | E63-SR5C |

Note: Order the Encoder and Receiver Unit as a set.

■ ACCESSORIES (ORDER SEPARATELY)

| Name | Part Number |
|----------|-----------------|
| Coupling | E69-C06B |

Specifications

■ RATINGS/CHARACTERISTICS

| | | | |
|--|--|--|--|
| Part number | E6C-MPZ1X2 | | E63-SR5C |
| Power supply voltage | --- | | 12 VDC ^{-10%} to 24 VDC ^{+15%} |
| Current consumption | 150 mA max. (see note 1) | | 150 mA max. |
| Resolution | Absolute | 2,048/rotation (11 bits) 4,096 rotations (12 bits) | --- |
| | Incremental | 2048/rotation | --- |
| Output code (absolute) | --- | | Pure binary |
| Output phases (incremental) | --- | | A, B, and Z |
| Phase difference on output (incremental) | --- | | 90°±45° (1/4T±1/8T) between A and B |
| Output configuration | --- | | NPN open collector |
| Output capacity | --- | | Applied voltage: 30 VDC max. I _{sink} : 20 mA max. Residual voltage: 0.4 V max. (I _{sink} : 20 mA) |
| Max. response frequency | 150 kHz (incremental signal) | | --- |
| Max. rotational frequency response | 4,500 rpm (1,000 rpm from 1 s after a power interruption) (see note 2) | | --- |
| Condenser backup time | 20 hrs (typical) | | --- |
| Battery backup time | --- | | 5 years min. Internal ER17/33 lithium battery (1500 mAh Hitachi Maxell battery) |
| Rotational direction | Output code incremented by clockwise rotation | | --- |
| Starting torque | 100 gf • cm (9.8 mN • m) max. | | --- |
| Moment of inertia | 15 g • cm ² (15 x 10 ⁻⁷ kg • m ²) max. | | --- |
| Shaft loading | Radial | 5 kgf (49 N) | --- |
| | Thrust | 3 kgf (29.4 N) | --- |
| Ambient temperature | Operating | -10°C to 70°C (14°F to 158°F) with no icing | -10°C to 55°C (14°F to 131°F) with no icing |
| | Storage | -25°C to 70°C (-13°F to 158°F) with no icing | -25°C to 65°C (-13°F to 149°F) with no icing |
| Ambient humidity | Operating | 35% to 85% (with no condensation) | |
| Insulation resistance | 20 MΩ min. (at 100 VDC) between carry parts and case | | |
| Dielectric strength | 1,000 VAC, 50/60 Hz for 1 min between carry parts and case | | |
| Vibration resistance | Destruction | 10 to 500 Hz, 1-mm single amplitude (150 m/s ² (approx. 15G)) for 11 min 3 times each in X, Y, and Z directions | 10 to 150 Hz, 0.75-mm single amplitude (100 m/s ² (approx. 10G)) for 8 min 4 times each in X, Y, and Z directions |
| Shock resistance | Destruction | 1,000 m/s ² (approx. 100G) 3 times each in X, Y, and Z directions | 300 m/s ² (approx. 30G) 3 times each in X, Y, and Z directions |
| Enclosure ratings | IEC | IP64 watertight (JEC IP64F oil resistive) | |
| Weight | 350 g (cable: 2 m, with connector) | | 350 g |

- Note: 1. When the Encoder's internal condenser is completely discharged, there will be an inrush current of 300 mA max. for about 2 s. Also, the battery alarm might go ON if the condenser is discharged; in this case, reset the Encoder with the ERS (Encoder Reset Input) before operation.
2. If the main power supply is interrupted, the Encoder's internal condenser and Receiver Unit's internal battery will supply power to retain rotational frequency data and continue rotational measurement. The Encoder can continue to respond to 4,500 rpm rotation for 1 second after the main power is interrupted, but thereafter the maximum rotational frequency response drops to 1,000 rpm. This feature allows the Encoder to keep up with the rotational speed of devices which continue to rotate due to inertia after a power interruption.

Operation

■ E63-SR5C SPECIFICATIONS

Connections

| Pin no. | Symbol | Signal | | Function |
|---------|--------|-------------------------------------|---------------------------------|--|
| | | Single-rotation absolute data | Multiple-rotation absolute data | |
| 1 | ABS0 | --- | 2^0 | --- |
| 2 | ABS1 | --- | 2^1 | --- |
| 3 | ABS2 | 2^0 | 2^2 | --- |
| 4 | ABS3 | 2^1 | 2^3 | --- |
| 5 | ABS4 | 2^2 | 2^4 | --- |
| 6 | ABS5 | 2^3 | 2^5 | --- |
| 7 | ABS6 | 2^4 | 2^6 | --- |
| 8 | ABS7 | 2^5 | 2^7 | --- |
| 9 | ABS8 | 2^6 | 2^8 | --- |
| 10 | ABS9 | 2^7 | 2^9 | --- |
| 11 | ABS10 | 2^8 | 2^{10} | --- |
| 12 | ABS11 | 2^9 | 2^{11} | --- |
| 13 | ABS12 | 2^{10} | --- | --- |
| 14 | ABS13 | --- | --- | --- (see note 8) |
| 15 | ABS14 | --- | --- | --- (see note 8) |
| 16 | ABS15 | --- | --- | --- (see note 8) |
| 17 | STR0 | Strobe 0 output | | Strobe output for single-rotation absolute data |
| 18 | STR1 | Strobe 1 output | | Strobe output for multiple-rotation absolute data |
| 19 | GND | 0 V | | 0 V for outputs |
| 20 | BAL | Battery alarm output | | Output when the internal battery's voltage drops (see note 1) |
| 21 | OFW | Overflow alarm output | | (see note 2) |
| 22 | CHK | Open-circuit detection alarm output | | Output when a broken circuit is detected in the connection to the Encoder. |
| 23 | ERR | Communication error output | | Output when a communication error from the Encoder is detected. |
| 24 | VCC | Power supply 12 to 24 VDC | | --- |
| 25 | VCC | Power supply 12 to 24 VDC | | --- |
| 26 | GND | Power supply 0 V | | --- |
| 27 | GND | Power supply 0 V | | --- |
| 28 | ERS | Encoder reset input | | H: Active (2 s min.) (see note 3) |
| 29 | RST | Reset input | | L: Active (see note 4) (see note 7) |
| 30 | RQ0 | Request 0 input | | H: Active (see note 5) |
| 31 | RQ1 | Request 1 input | | H: Active (see note 6) |
| 32 | GND | 0 V | | --- |
| 33 | A | Incremental phase-A output | | --- |
| 34 | GND | 0 V | | --- |
| 35 | B | Incremental phase-B output | | --- |
| 36 | GND | 0 V | | --- |
| 37 | Z | Incremental phase-Z output | | --- |

- Note:
1. This signal is output when the battery voltage drops below 3.0 V.
 2. This signal is output if the Encoder's multiple-rotation value exceeds 4,096 during clockwise rotation or falls below 0 during counter-clockwise rotation.
 3. The multiple-rotation value and overflow alarm are reset by the BAL (battery alarm output). This is a high-active signal, so input a high signal (12 to 24 V) for 2 s or more.
 4. Resets the open-circuit detection alarm and communications error. The RST input signal is the only low-active signal (2 V or less).
 5. The single-rotation absolute data is output when this signal is input.
 6. The multiple-rotation absolute data is output when this signal is input.
 7. When the RST (reset input) is being input, absolute data outputs and alarm outputs cannot be read and input signals cannot be received.
 8. The ABS13, ABS14, and ABS15 single-rotation absolute data signals might go ON occasionally, but these signals cannot be used as data.

I/O SPECIFICATIONS

Input

| | |
|---------------|--------------|
| Input voltage | 12 to 24 VDC |
| Input current | 1 to 3 mA |

Note: When connecting PC outputs to E63-SR5C inputs, use positive-common PC outputs such as those in the C200H-OD217.

Circuits

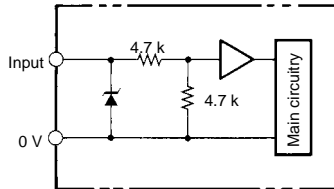

Output

| | |
|----------------------|---|
| Output configuration | NPN open collector |
| Output capacity | Applied voltage: 30 VDC max. I _{sink} current: 20 mA max. Residual voltage: 0.4 V max. |

Circuits

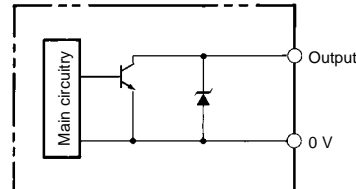

DATA OUTPUT TIMING

(A) Request Mode

When the request signal is input, data is output along with the strobe signal.

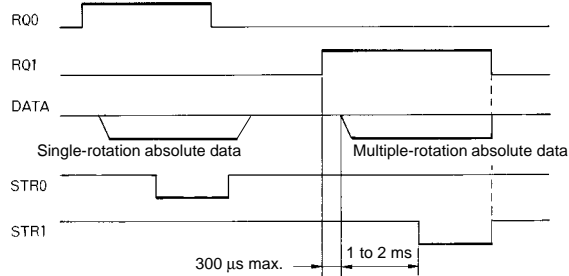

(B) Strobe Mode

Data is output in order along with the strobe signal.

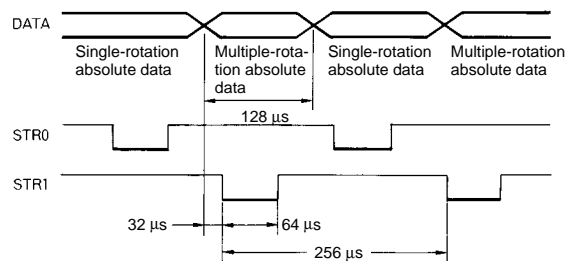

- Note:
1. Switch between strobe mode and request mode with the mode switch.
 2. In request mode, RQ0 (request input 0) has priority over RQ1 (request input 1), so RQ1 cannot be received while RQ0 is ON. Input RQ0 and RQ1 separately.
 3. Since absolute data is transmitted serially between the Encoder and Receiver Unit, there is a 256-μs delay in data transfer. This delay causes real-time data response to be lost at a rotational frequency of more than 100 rpm.

DISPLAY

| Name | Color | Function |
|-------|--------|---|
| POWER | Green | Lights when the power supply is on |
| CHK | Red | Lights when there is an open circuit in the signal line |
| OFW | Red | Lights when there is an overflow error |
| ERR | Red | Lights when there is a communications error |
| BAL | Red | Lights when battery voltage drops |
| Z | Orange | Phase-Z origin indicator |

DATA OUTPUT MODE SWITCH

| Mode | Name | Function |
|------|--------------|---|
| A | Request mode | Data is output when the request signal is input |
| B | Strobe mode | Data is always output in order |

OUTPUT CIRCUIT DIAGRAM

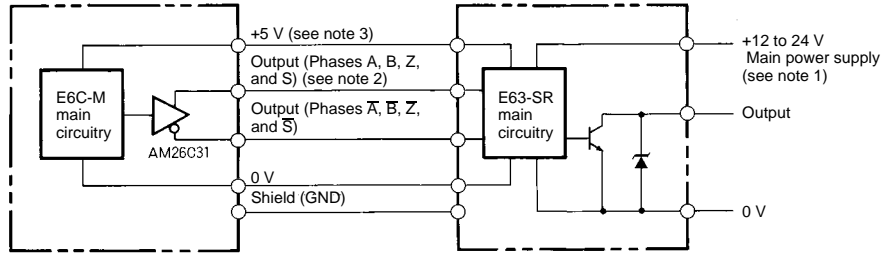

- Note:
1. The Encoder's data communication will stop when the main power supply goes off, but the Encoder's internal condenser and Receiver Unit's internal battery will supply power to retain multiple-rotation absolute data and measure rotational frequency.
 2. Phase S: Absolute serial data output
 Phase A: Incremental phase-A output
 Phase B: Incremental phase-B output
 Phase Z: Incremental phase-Z output
 Refer to the separate specifications for each model for details on data transfer formats.
 3. There is a voltage feedback function that adjusts for the drops in the voltage supplied to the Encoder due to the length of the encoder cable, which maintains a steady voltage level.

TIMING CHARTS

Absolute Signal

Direction of resolution: CW
 (As viewed from the end of the shaft)

Single-rotation absolute data: 2047
 Multiple-rotation absolute data: (4095)
 (see note)

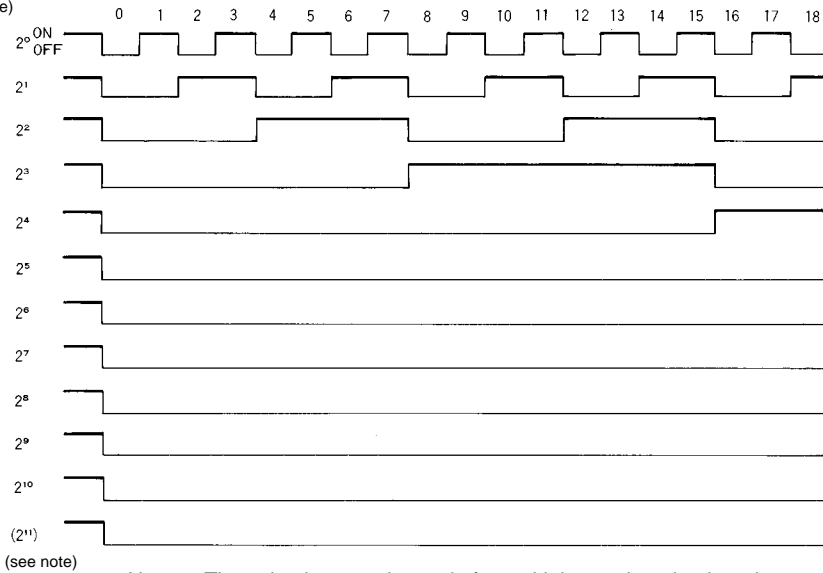

Note: The value in parentheses is for multiple-rotation absolute data.

Incremental Signal

Direction of resolution: CW
 (As viewed from the end of the shaft)

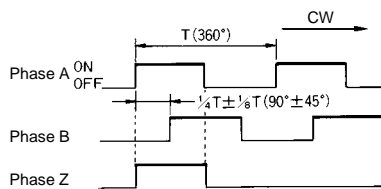

Note: Phase A is $1/4 \pm 1/8 T$ ($90^\circ \pm 45^\circ$) faster than phase B.

Direction of resolution: CCW
 (As viewed from the end of the shaft)

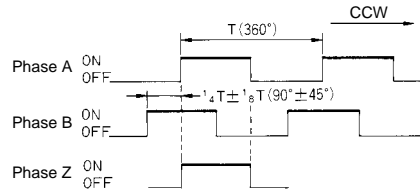

Note: Phase A is $1/4 \pm 1/8 T$ ($90^\circ \pm 45^\circ$) slower than phase B.

Dimensions

Unit: mm (inch)

ENCODERS

E6C-MPZ1X2

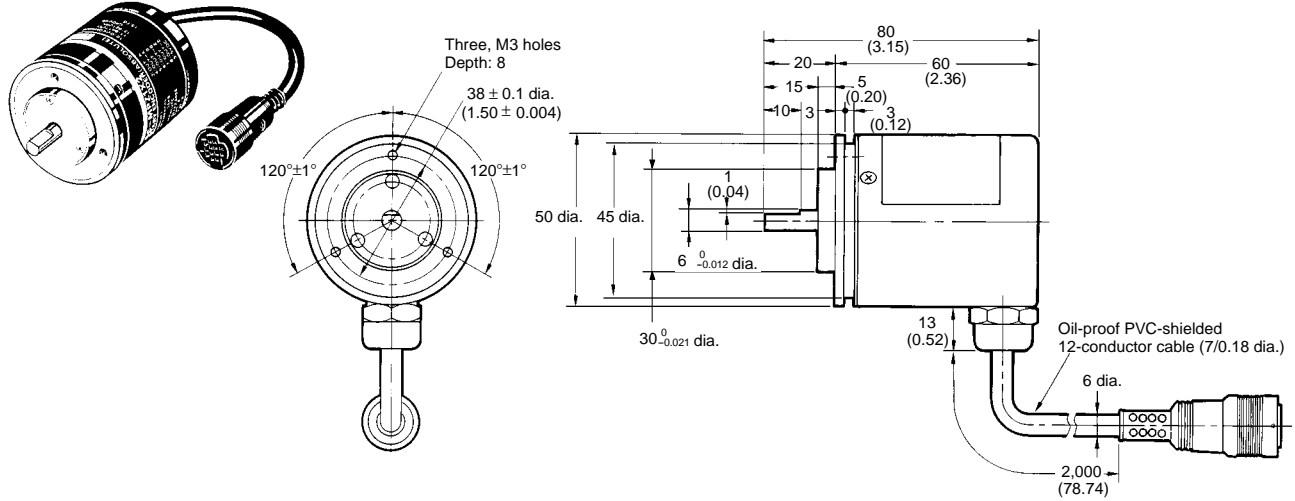

E63-SR5C Receiver Unit

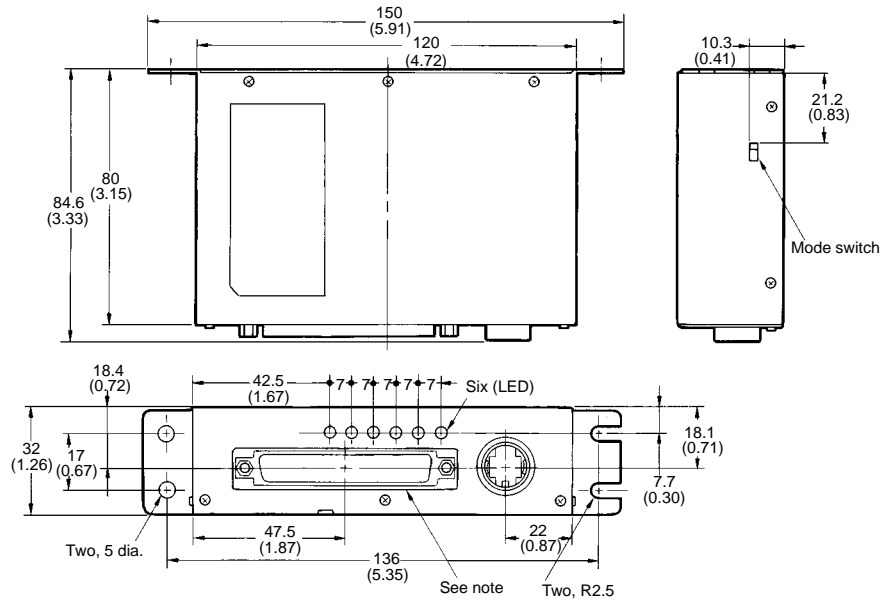
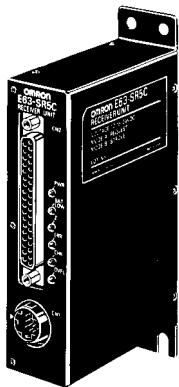

Note: OMRON 37-pin D-sub Connector
 XM-2A-3701 (plug)
 XM-2A-3712 (hood)

Mounting Holes

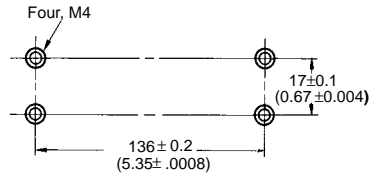

■ ACCESSORIES

Mounting Bracket (Attached)

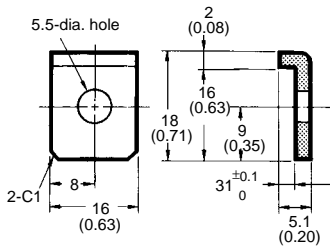

Mounting Bracket Installation

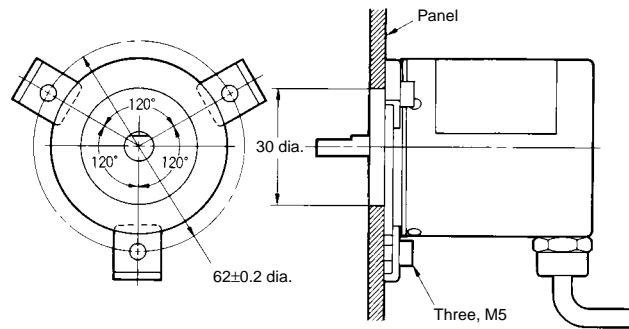

E69-C06B Coupling (Order Separately)

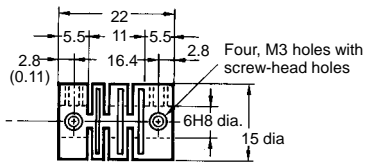

Note: Material: Glass-reinforced PBT

Installation

■ CONNECTION EXAMPLE 1

PC Connection (Request Mode)

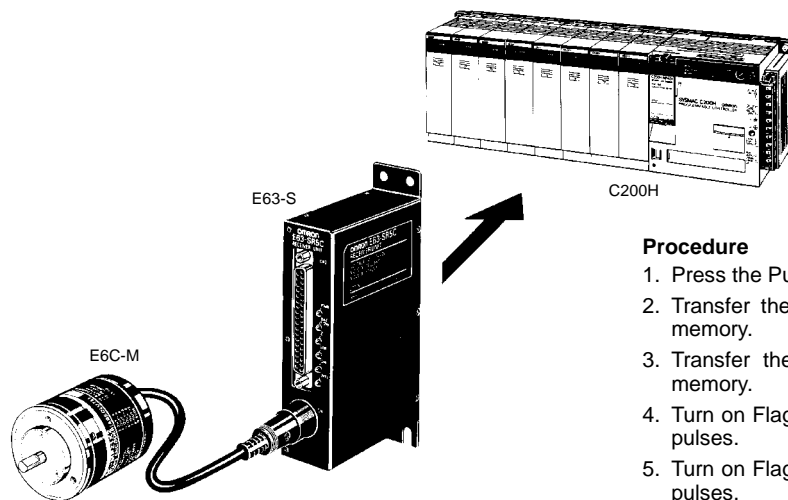

Procedure

1. Press the Push (PB) Button.
2. Transfer the multiple-rotation absolute data to the PC's data memory.
3. Transfer the single-rotation absolute data to the PC's data memory.
4. Turn on Flag #1 if the above data exceeds 2 rotations and 300 pulses.
5. Turn on Flag #2 if the above data exceeds 3 rotations and 500 pulses.

Connections

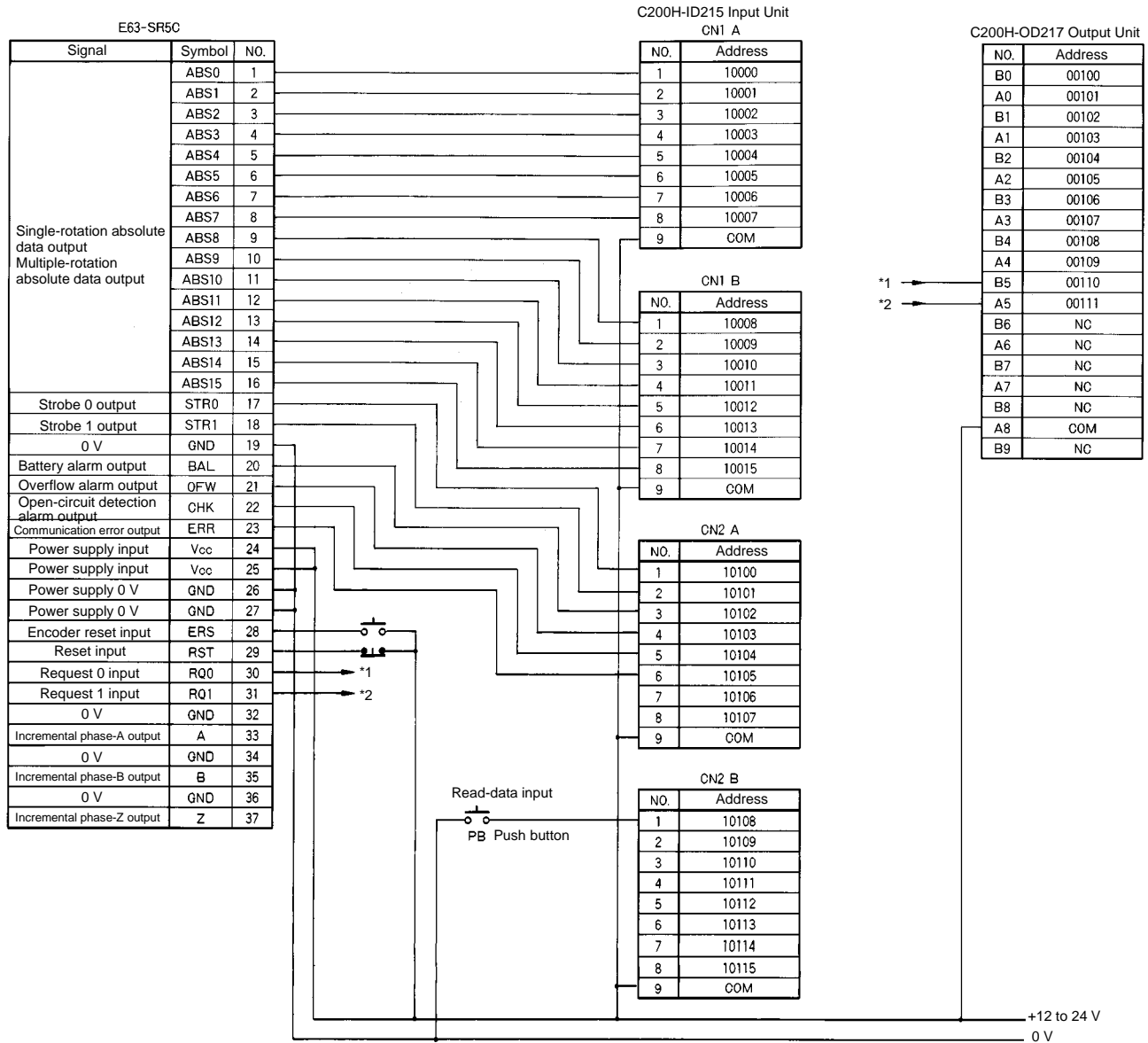

Sample Program

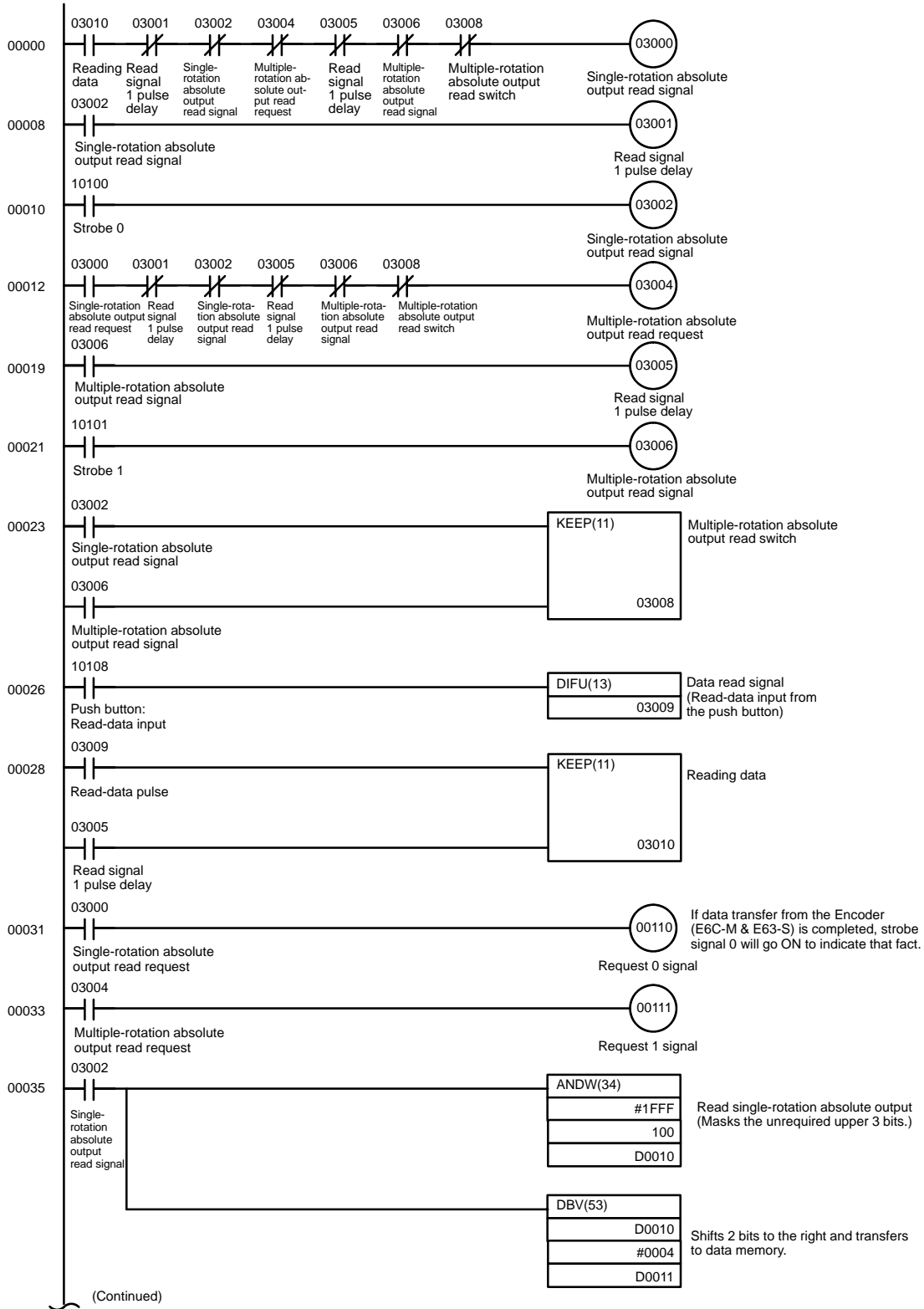

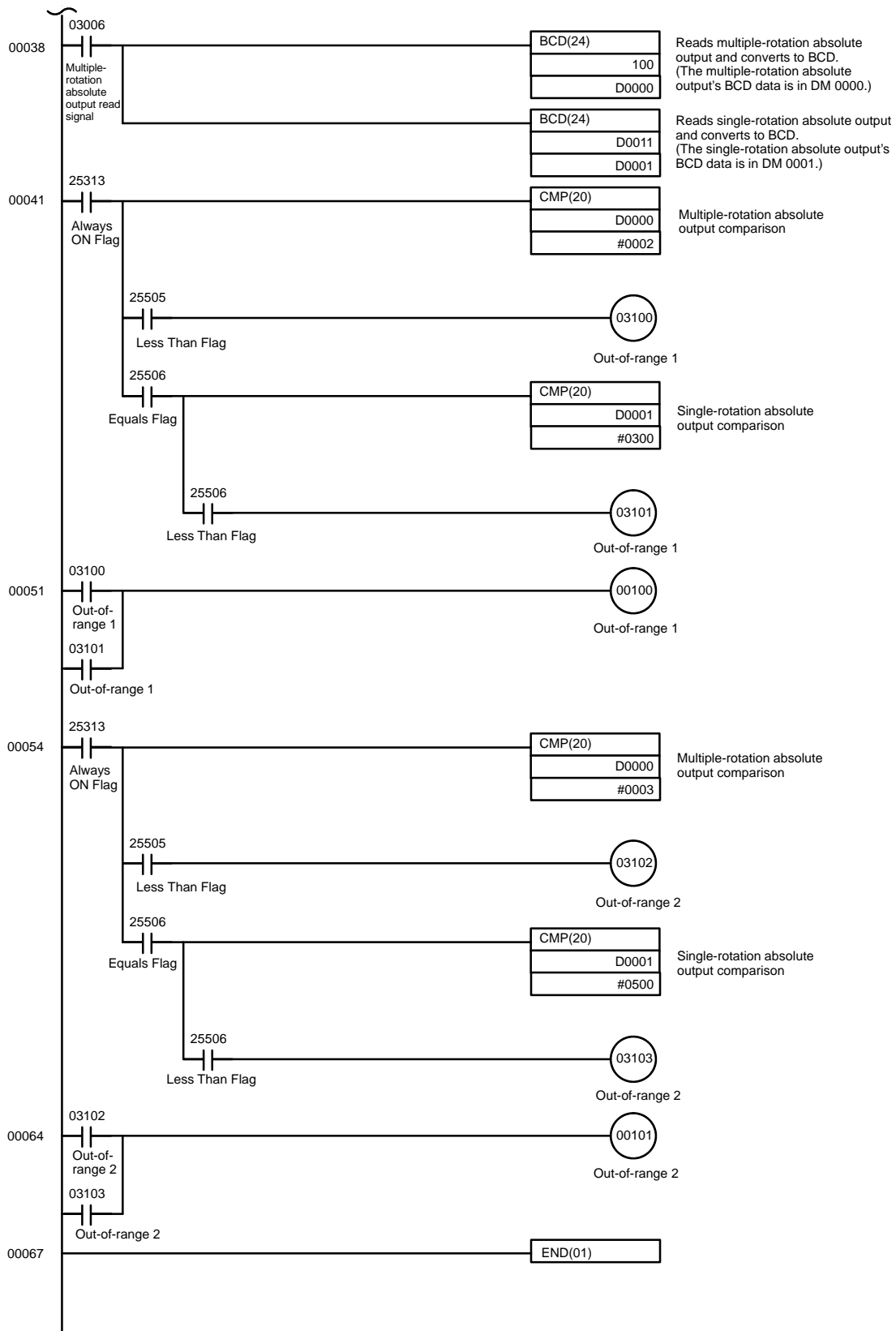

■ CONNECTION EXAMPLE 2

PC Connection (Strobe Mode)

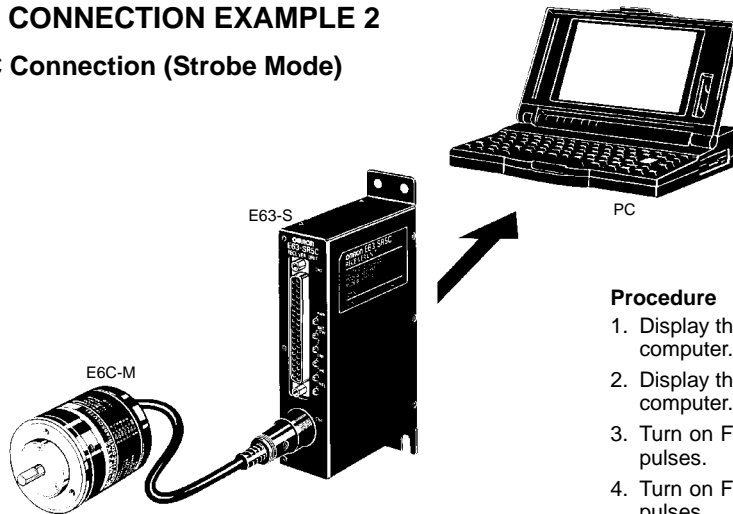

Procedure

1. Display the multiple-rotation absolute data at the personal computer.
2. Display the single-rotation absolute data at the personal computer.
3. Turn on Flag #1 if the above data exceeds 2 rotations and 300 pulses.
4. Turn on Flag #2 if the above data exceeds 3 rotations and 500 pulses.

Connections

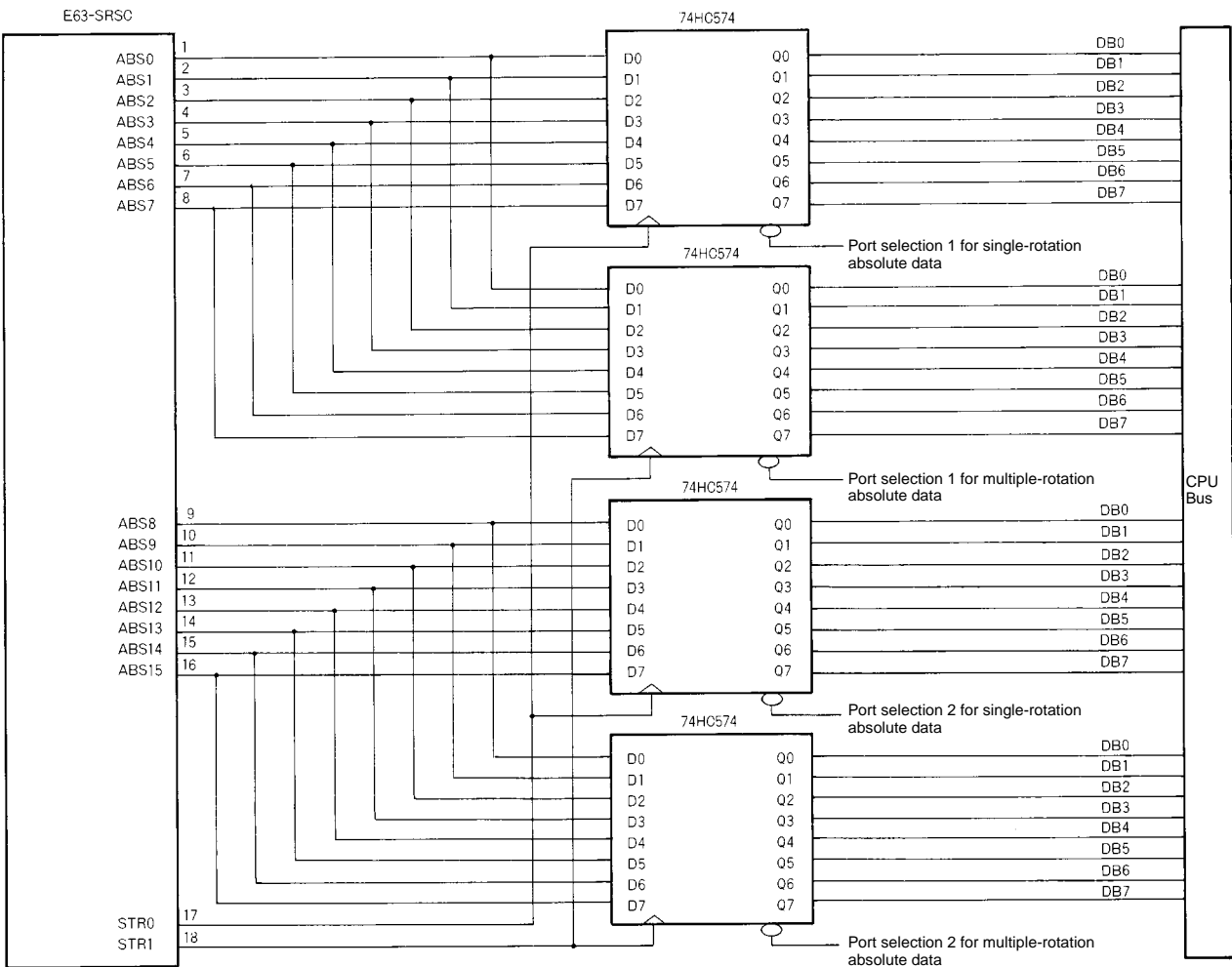

Note: The following port selections are used in the sample program on the next page:
 Port selection 1 for single-rotation absolute data: ABS_SEL1(&H00D0)
 Port selection 2 for single-rotation absolute data: ABS_SEL2(&H00D2)
 Port selection 1 for multiple-rotation absolute data: TAKAITEN_SEL1(&H00D4)
 Port selection 2 for multiple-rotation absolute data: TAKAITEN_SEL1(&H00D8)

Sample Program

```

100 REM *****
110 REM Displays the single-rotation absolute data.
120 REM
130 REM *****

200 ABS_SEL1  =&H00D0          Single-rotation absolute data (lower byte) input latch port address
210 ABS_SEL2  =&H00D2          Single-rotation absolute data (higher byte) input latch port address

220 KAITENRYO_LOW=INP(ABS_SEL1)      Reads the single-rotation absolute data (lower byte).
230 KAITENRYO_HI =INP(ABS_SEL2)      Reads the single-rotation absolute data (higher byte).
240 KAITENRYO=KAITENRYO_LOW+(KAITENRYO_HI*256)  Converts the single-rotation absolute data to 16-bit data.
250 KAITENRYO=KAITENRYO AND &H1FFC    Masks the unneeded bits.
260 KAITENRYO=KAITENRYO /4           Shifts 2 bits right.
270 PRINT KAITENRYO                Displays the single-rotation absolute data.
280 END

100 REM *****
110 REM Displays the multiple-rotation absolute data.
120 REM
130 REM *****

200 TAKAITEN_SEL1=&H00D4          Multiple-rotation absolute data (lower byte) input latch port address
210 TAKAITEN_SEL2=&H00D6          Multiple-rotation absolute data (higher byte) input latch port address

220 KAITENSUU_LOW=INP(TAKAITEN_SEL1)  Reads the multiple-rotation absolute data (lower byte).
230 KAITENSUU_HI =INP(TAKAITEN_SEL2)  Reads the multiple-rotation absolute data (higher byte).
240 KAITENSUU=KAITENSUU_LOW+(KAITENSUU*256)  Converts the multiple-rotation absolute data to 16-bit data.
250 KAITENSUU=KAITENSUU AND &HFFF      Masks the unneeded bits.
260 PRINT KAITENSUU                Displays the multiple-rotation absolute data.
270 END

100 REM *****
110 REM Turns on flags if the set values are exceeded.
120 REM
130 REM *****

200 ABS_SEL1      =&H00D0          Single-rotation absolute data (lower byte) input latch port address
210 ABS_SEL2      =&H00D2          Single-rotation absolute data (higher byte) input latch port address
220 TAKAITEN_SEL1 =&H00D4          Multiple-rotation absolute data (lower byte) input latch port address
230 TAKAITEN_SEL2 =&H00D6          Multiple-rotation absolute data (higher byte) input latch port address
240 SETTEI_KAITENRYO1    =300      Single-rotation absolute data #1 set value (300 pulses)

250 SETTEI_KAITENSUU1    =2         Multiple-rotation absolute data #1 set value (2 rotations)
260 SETTEI_KAITENRYO2    =500      Single-rotation absolute data #2 set value (500 pulses)
270 SETTEI_KAITENSUU2    =3         Multiple-rotation absolute data #2 set value (3 rotations)
280 OVER_FLG1           =0         Over #1 set value flag
290 OVER_FLG2           =0         Over #2 set value flag

300 KAITENRYO_LOW=INP(ABS_SEL1)      Reads the single-rotation absolute data (lower byte).
310 KAITENRYO_HI =INP(ABS_SEL2)      Reads the single-rotation absolute data (higher byte).
320 KAITENRYO=KAITENRYO_LOW+(KAITENRYO_HI*256)  Converts the single-rotation absolute data to 16-bit data.
330 KAITENRYO=KAITENRYO AND &H1FFC    Masks the unneeded bits.
340 KAITENRYO=KAITENRYO /4           Shifts 2 bits right.

400 KAITENSUU_LOW=INP(TAKAITEN_SEL1)  Reads the multiple-rotation absolute data (lower byte).
410 KAITENSUU_HI =INP(TAKAITEN_SEL2)  Reads the multiple-rotation absolute data (higher byte).
420 KAITENSUU=KAITENSUU_LOW+(KAITENSUU*256)  Converts the multiple-rotation absolute data to 16-bit data.
430 KAITENSUU=KAITENSUU AND &HFFF      Masks the unneeded bits.

500 *CHECK1
510 IF KAITENSUU=SETTEI_KAITENSUU1 ELSE GOTO*CHECK2      If the multiple-rotation absolute data equals its #1 set value and
520 IF KAITENRYO>=SETTEI_KAITENRYO1 THEN OVER_FLG1=1    the single-rotation absolute data exceeds its #1 set value, the
                                                         "over #1 set value flag" is turned on.

600 *CHECK2
610 IF KAITENSUU>SETTEI_KAITENSUU1 ELSE GOTO *CHECK3      If the multiple-rotation absolute data exceeds its #1 set value,
                                                         the "over #1 set value flag" is turned on.

620 OVER_FLG1=1

```

```

700 *CHECK3
710 IF KAITENSUU=SETTEI_KAITENSUU2 ELSE GOTO *CHECK4
720 IF KAITENRYO>=SETTEI_KAITENRYO2 THEN OVER_FLG2=1

800 *CHECK4
810 IF KAITENSUU>SETTEI_KAITENSUU2 ELSE GOTO *EXIT
820 OVER_FLG2=1

900 *EXIT
910 END

```

If the multiple-rotation absolute data equals its #2 set value and the single-rotation absolute data exceeds its #2 set value, the "over #2 set value flag" is turned on.

If the multiple-rotation absolute data exceeds its #2 set value, the "over #2 set value flag" is turned on.

Note: The KAITENRYO variable is the single-rotation absolute data and the KAITENSUU variable is the multiple-rotation absolute data.

Precautions

■ STORAGE CONDITIONS

Store the E6C-M within the temperature and humidity ranges given in the specifications and observe the following precautions.

- Store the Unit and packaging where they won't be subjected to salt air or corrosive gases such as hydrogen sulfide.
- Store the Unit in a dust-free area where it can be inspected visually.
- Do not store the Unit in direct sunlight.
- Also, never place a load on the Unit that could deform or damage it.

■ OPERATING CONDITIONS

Operate the E6C-M within the temperature and humidity ranges given in the specifications and observe the following precautions.

- Install the Unit in a low-dust location free of corrosive gases.
- Install the Unit in a location free of water and oil where the effects of vibration and shock are insignificant.
- Avoid locations with sudden temperature changes, even if the temperature range is within the recommended limits.
- Also, never place a load on the Unit that could deform or damage it.

■ WIRING

- Insert a surge absorber between the power supply terminals if there is any surge.
- Turn off the Rotary Encoder when wiring. The output circuit may be damaged if the output line contacts with the power source while the Rotary Encoder is turned on.
- Never disconnect or connect the circuit when current is flowing. This might damage the Unit.
- Avoid wiring the E6C-M and E63-SRC's cables parallel to power lines or high-voltage lines. Use a separate conduit.

Spurious pulses might be generated when power is turned on, so wait at least 0.3 s after the last Unit is turned on before using the Units.

■ MOUNTING

The Rotary Encoder consists of high-precision components. Handle with utmost care and do not drop the Rotary Encoder, or malfunctioning may result.

- When installing the Encoder, be sure not to apply excessive force or shock to the rotational shaft.
- Use a coupling on the rotational shaft and be sure to avoid excessive shock or vibration during operation.
- When inserting the shaft in the coupling, do not use excessive force (by striking it with a hammer, for example).
- If the E6C-M is mounted and wired with a cable, do not pull the cable.
- When using a gear linkage, be sure not to apply a large load on the shaft.
- If a significant installation error is made (misalignment), the shaft will be subjected to excessive force which will damage it or shorten the life of the Unit.
- When linking with a chain timing belt or toothed gear, connect a separate bearing before the coupling to the encoder.

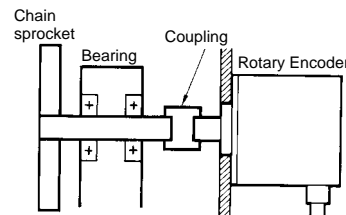

NOTE: DIMENSIONS SHOWN ARE IN MILLIMETERS. To convert millimeters to inches divide by 25.4.

OMRON[®]

OMRON ELECTRONICS, INC.

One East Commerce Drive

Schaumburg, IL 60173

1-800-55-OMRON

OMRON CANADA, INC.

885 Milner Avenue

Scarborough, Ontario M1B 5V8

416-286-6465