

### Industrial Strength Encoder Meets World-Class Standards

- Drip-proof construction
- Shaft withstands heavy loads, 5 kgf radially, 3 kgf thrust (axially)
- Short circuit protection
- Space-saving, A-slant cable protrusion for ease of mounting



### Ordering Information

Supply voltage	Output configuration	Resolution (P/R)	Part number
5 to 24 VDC	NPN open collector output	10, 20, 30, 40, 50, 60, 100, 200, 300, 360, 400, 500, 600, 1,000, 1,200, 1,500, 1,800, 2,000	<b>E6C2-CWZ6C</b>
5 to 12 VDC	Voltage output		<b>E6C2-CWZ3E</b>
5 VDC	Line driver output		<b>E6C2-CWZ1X</b>
12 to 24 VDC	PNP open collector output	100, 200, 360, 500, 600, 1,000, 2,000	<b>E6C2-CWZ5B</b>

Note: The power supply for the resolutions of 1,000, 1,200, 1,500, 1,800, and 2,000 is 12 to 24 VDC.

### ■ ACCESSORIES (ORDER SEPARATELY)

Item	Description	Part number
Coupling	---	<b>E69-C06B</b>
	Incorporates ends different to each other in diameter	<b>E69-C68B</b>
	Metal construction	<b>E69-C06M</b>
Flange	---	<b>E69-FCA</b>
	---	<b>E69-FCA-02</b>
Servo mounting bracket	Provided with the E69-FCA02 flange	<b>E69-2</b>

# Specifications

## ■ RATINGS/CHARACTERISTICS

### Electrical

Item	E6C2-CWZ6C	E6C2-CWZ3E	E6C2-CWZ1X	E6C2-CWZ5B
Power supply voltage	5 to 24 VDC (allowable range: 4.75 to 27.6 VDC)	5 to 12 VDC (allowable range: 4.75 to 13.2 VDC)	5 VDC±5%	12 VDC -10% to 24 VDC +15%
Current consumption (See Note 1.)	80 mA max.	100 mA max.	160 mA max.	100 mA max.
Resolution	10, 20, 30, 40, 50, 60, 100, 200, 300, 360, 400, 500, 600, 1,000, 1,200, 1,500, 1,800, 2,000 P/R			100, 200, 360, 500, 600, 1,000, 2,000 P/R
Output phases	A, B, and Z (reversible)		A, $\bar{A}$ , B, $\bar{B}$ , Z, $\bar{Z}$	A, B, and Z (reversible)
Output configuration	NPN open collector output	Voltage output (NPN output)	Line driver (See Note 2.)	PNP open collector output
Output capacity	Applied voltage: 30 VDC max. $I_{\text{sink}}$ : 35 mA max. Residual voltage: 0.4 V max. ( $I_{\text{sink}}$ : 35 mA max.)	Output resistance: 2 k $\Omega$ (residual voltage: 0.4 V max. $I_{\text{sink}}$ : 20 mA max.)	AM26LS31 Output current: High level ( $I_{\text{O}}$ ): -20 mA Low level ( $I_{\text{S}}$ ): 20 mA Output voltage: $V_{\text{O}}$ : 2.5 V min. $V_{\text{S}}$ : 0.5 V max.	$I_{\text{sink}}$ : 35 mA max. Residual voltage: 0.4 V max. ( $I_{\text{sink}}$ : 35 mA max.)
Max. response frequency (See Note 3.)	100 kHz			50 kHz
Phase difference on output	90°±45° between A and B (1/4T±1/8T)			
Rise and fall times of output	1 $\mu$ s max. (control output voltage: 5 V; load resistance: 1 k $\Omega$ ; cable length: 2 m)	1 $\mu$ s max. (cable length: 2 m; $I_{\text{sink}}$ : 10 mA max.)	0.1 $\mu$ s max. (cable length: 2 m; $I_{\text{O}}$ : -20 mA; $I_{\text{S}}$ : 20 mA)	1 $\mu$ s max. (cable length: 2 m; $I_{\text{sink}}$ : 10 mA max.)
Insulation resistance	100 M $\Omega$ min. (at 500 VDC) between carry parts and case			
Dielectric strength	500 VAC, 50/60 Hz for 1 min between carry parts and case			

- Note: 1. An inrush current of approx. 9 A flows for approx. 0.3 ms right after the E6C2-C is turned on.
2. The line driver output of the E6C2-C is used for data transmission circuitry conforming to RS-422A and ensures long-distance transmission over twisted-pair cable, with quality equivalent to AM26LS31.
3. The maximum electrical response revolution is determined by the resolution and maximum response frequency as follows:  
Maximum electrical response frequency (rpm) = maximum response frequency/resolution x 60  
This means that the E6C2-C Rotary Encoder will not operate electrically if its revolution exceeds the maximum electrical response revolution.

## MECHANICAL

Item		E6C2-CWZ6C	E6C2-CWZ3E	E6C2-CWZ1X	E6C2-CWZ5B
Shaft loading	Radial	5 kgf (49.0 N) 11.0 lbf			
	Thrust	3 kgf (29.4 N) 6.6 lbf			
Moment of inertia		10 g • cm <sup>2</sup> (1 × 10 <sup>-6</sup> kg • m <sup>2</sup> ) max.; 3 g • cm <sup>2</sup> (3 × 10 <sup>-7</sup> kg • m <sup>2</sup> ) max. at 600 P/R max. 6.6 × 10 <sup>3</sup> lb/in .85 × 10			
Starting torque		100 gf • cm (9.8 mN • m) max. (7.2 m ft • lbf)			
Max. permissible revolution		6,000 rpm			
Vibration resistance		10 to 500 Hz, 150 m/s <sup>2</sup> (15G) or 2-mm double amplitude for 11 min 3 times each in X, Y, and Z directions			
Shock resistance		1,000 m/s <sup>2</sup> (100G) 3 times each in X, Y, and Z directions			
Weight		Approx. 400 g max. (cable length: 2 m) 0.88 lbs			

## ENVIRONMENTAL

Item		E6C2-CWZ6C	E6C2-CWZ3E	E6C2-CWZ1X	E6C2-CWZ5B
Ambient temperature	Operating	-10°C to 70°C (14°F to 158°F) with no icing			
	Storage	-25°C to 85°C (-13°F to 185°F) with no icing			
Ambient humidity	Operating	35% to 85% (with no condensation)			
Protective circuit		Protection from load short-circuiting and power supply reverse polarity wiring			
Degree of protection		IEC IP64 (JEM IP64f drip-proof) (See Note.)			

Note: The applicable JEM standard is JEM1030 1991.

## Operation

### OUTPUT CIRCUIT DIAGRAM

E6C2-CWZ6C

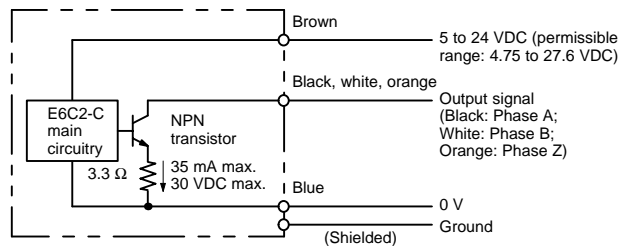

E6C2-CWZ3E

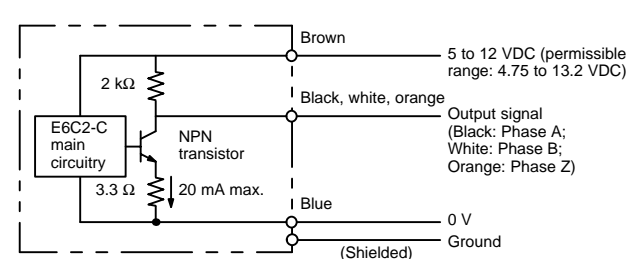

E6C2-CWZ1X

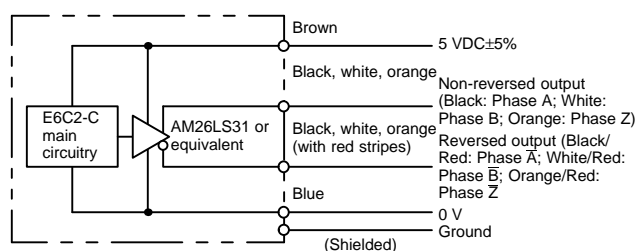

E6C2-CWZ5B

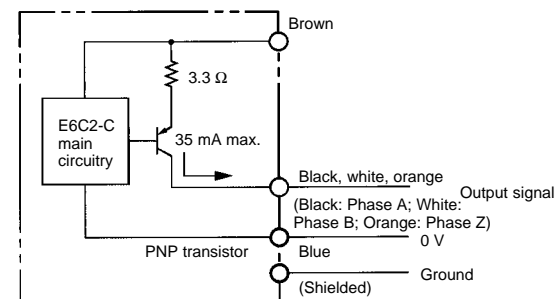

**■ TIMING CHARTS**

**NPN Open Collector Output  
E6C2-CWZ6C**

**PNP Open Collector Output  
E6C2-CWZ5B**

Direction or resolution: Clockwise (CW)  
(As viewed from the end of the shaft)

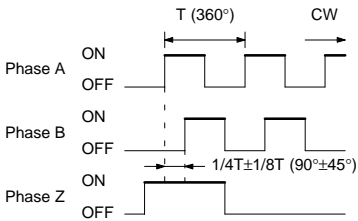

Note: Phase A is  $1/4 \pm 1/8T$  faster than phase B. The ONs in the above timing chart mean that the output transistor is ON and the OFFs mean that the output transistor is OFF.

Direction or resolution: Counterclockwise (CCW)  
(As viewed from the end of the shaft)

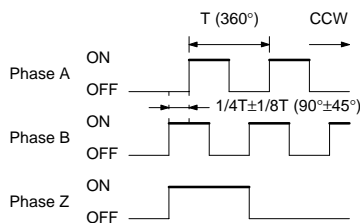

Note: Phase A is  $1/4 \pm 1/8T$  slower than phase B

**Voltage Output  
E6C2-CWZ3E**

Direction or resolution: Clockwise (CW)  
(As viewed from the end of the shaft)

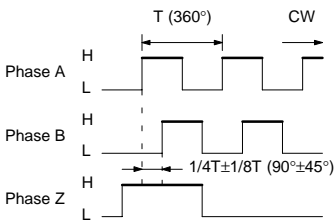

Note: Phase A is  $1/4 \pm 1/8T$  faster than phase B.

Direction or resolution: Counterclockwise (CCW)  
(As viewed from the end of the shaft)

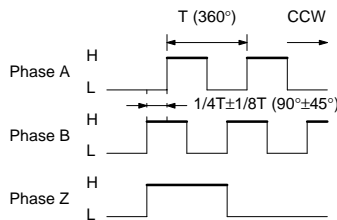

Note: Phase A is  $1/4 \pm 1/8T$  slower than phase B.

**■ LINE DRIVER OUTPUT**

**E6C2-CWZ1X**

Direction or resolution: Clockwise (CW)  
(As viewed from the end of the shaft)

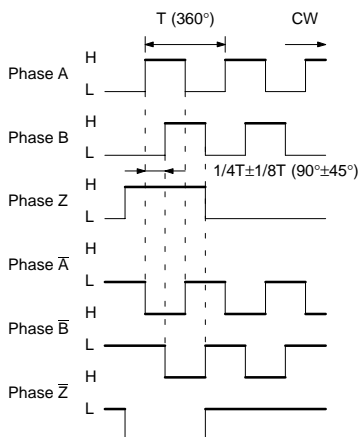

Direction or resolution: Counterclockwise (CCW)  
(As viewed from the end of the shaft)

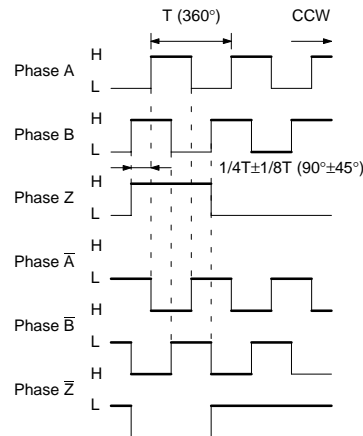

■ OUTPUT PROTECTION CIRCUIT

The E6C2-C with open collector or voltage output incorporates a circuit protecting the E6C2-C from damage resulting from load short-circuiting or wiring the output wrong.

■ ORIGIN INDICATION

It is easy to adjust the position of phase Z with the origin indication function. The illustration below on the left side shows the relationship between phase Z and the origin. Set cut face D to the origin as shown in the illustration on the right.

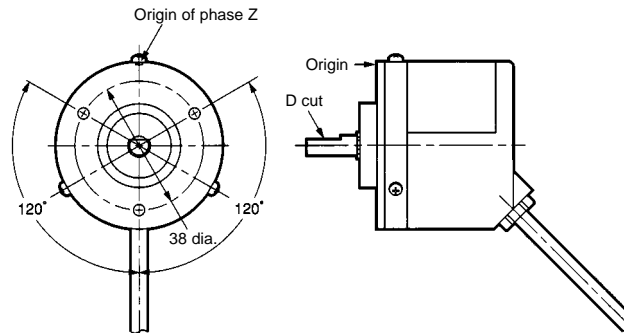

■ INPUT TO MORE THAN ONE COUNTER FROM ENCODER (WITH VOLTAGE OUTPUT)

Use the following formula to obtain the number of counters to be connected to a single E6C2-C Rotary Encoder.

$$\text{Number of counters (N)} = \frac{R1 (E-V)}{V \times R2}$$

- E: Voltage supplied to Rotary Encoder
- V: Minimum input voltage of the counter
- R2: Output resistance of the Rotary Encoder
- R1: Input resistance of the Rotary Encoder

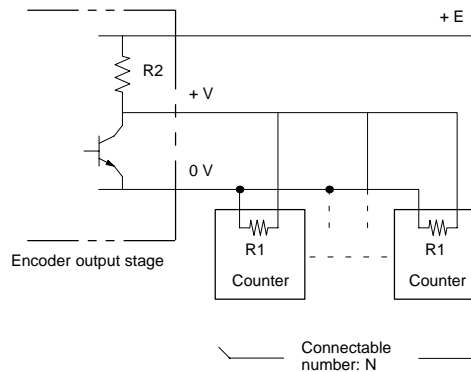

Dimensions

Unit: mm (inch)

■ E6C2-C

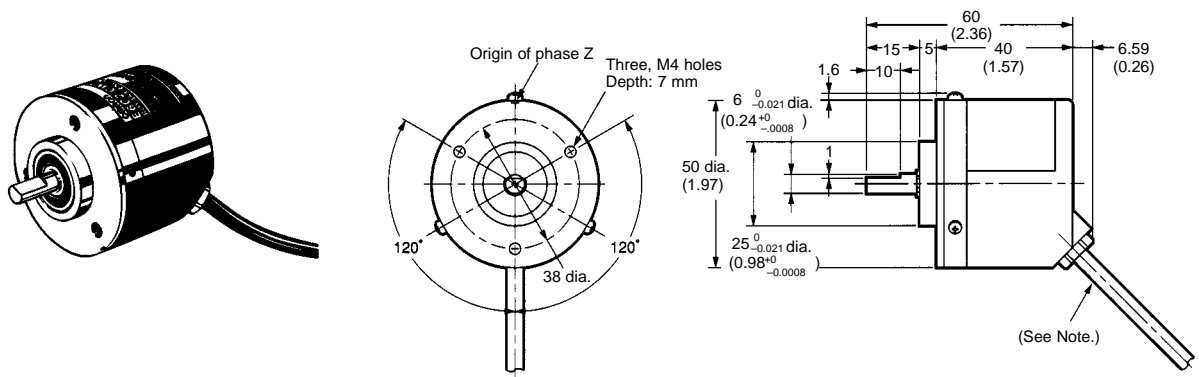

Note: 2-m-long, PVC code, 5-dia. (18/0.12 dia.) five conductors and shield (eight conductors for line driver use)

**ACCESSORIES (ORDER SEPARATELY)**

**Couplings**

**E69-C06B (Included)**

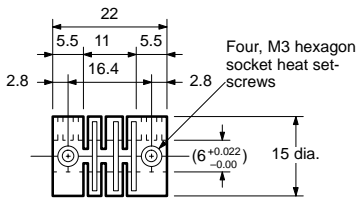

Note: The coupling is made of glass-reinforced PBT.

**E69-C68B (With Ends of Different Diameter)**

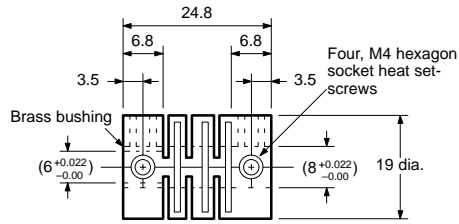

Note: The coupling is made of glass-reinforced PBT.

**E69-C06M (Metal Construction)**

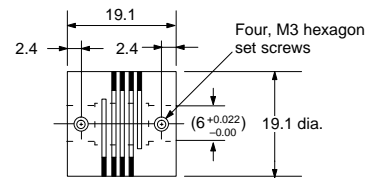

Note: Material: Super duralumin

**Flanges**

**E69-FCA**

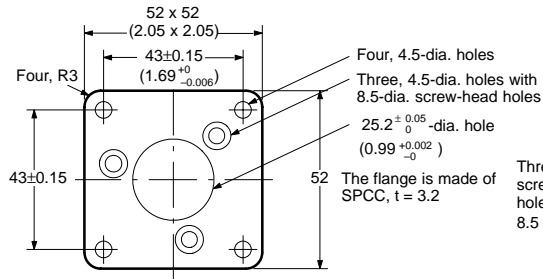

**E69-FCA-02**

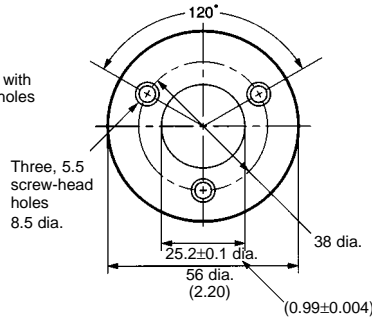

Note: Material: SPCC, t=3.2

Mounting bracket:  
(A set of three b333rackets provided with E69-FCA-02)

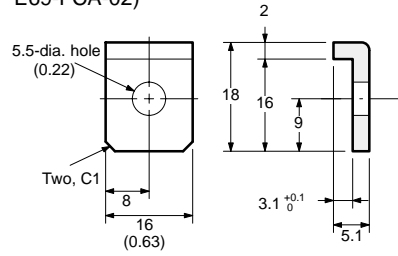

**Mounting Dimensions**

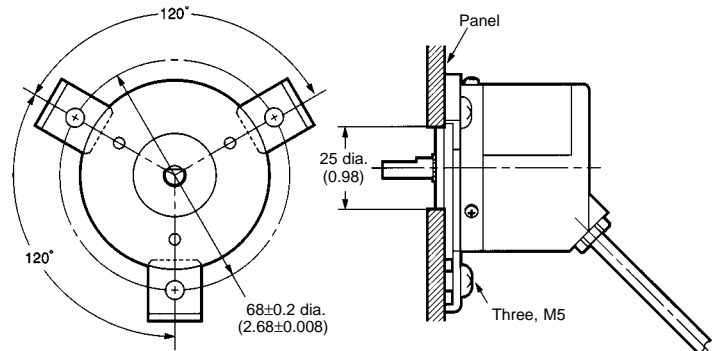

**SERVO MOUNTING BRACKET**

**E69-2 (A Set of Three)**

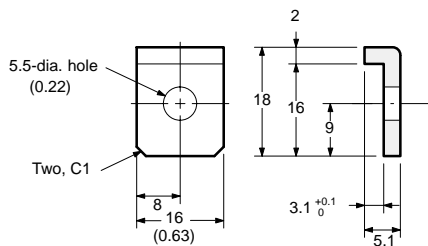

Note: A set of E69-2 servo mounting brackets is provided with the E69-FCA-02 flange.

# Installation

## ■ CONNECTION

### E6C2-CWZ6C/-CWZ3E

Color	Terminal
Brown	Power supply (+V <sub>CC</sub> )
Black	Output phase A
White	Output phase B
Orange	Output phase Z
Blue	0 V (common)

Note: Receiver: AM26LS32

### E6C2-CWZ1X

Color	Terminal
Brown	Power supply (+V <sub>CC</sub> )
Black	Output phase A
White	Output phase B
Orange	Output phase Z
Blue/Red stripes	Output phase $\bar{A}$
White/Red stripes	Output phase $\bar{B}$
Orange/Red stripes	Output phase $\bar{Z}$
Blue	0 V (common)

- Note: 1. The shield is not connected to the internal circuits or casing of the E6C2-C.  
 2. There is no difference in circuit among phases A, B, and Z.  
 3. Connect the GND terminal to 0 V or the ground when the E6C2-C is in normal operation.

# Connection Examples

## ■ H7ER SELF-POWERED TACHOMETER

Applicable Model: E6C2-CWZ3E (with a resolution of 10 or 60 P/R)

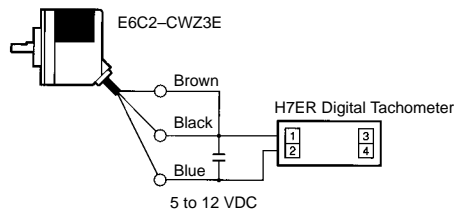

## ■ H7BR DIGITAL COUNTER

Applicable Model: E6C2-CWZ3E

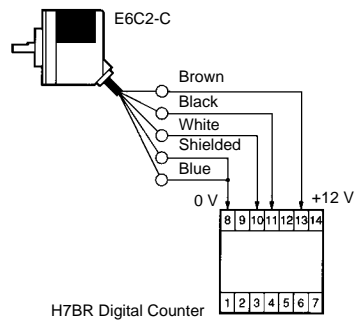

**■ H7CR-CW DIGITAL COUNTER**

Applicable Model: E6C2-CWZ6C

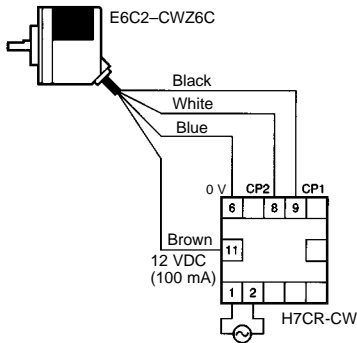

**■ CQM1 PROGRAMMABLE CONTROLLER**

Applicable Model: E6C2-CWZ6C

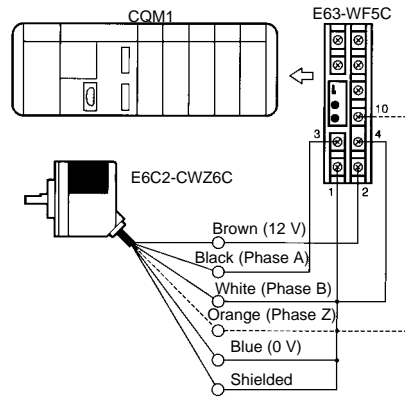

**■ C500-CT001/CT012 HIGH-SPEED COUNTER UNIT**

CW and CCW detection (increment/decrement counting)

Applicable Model: E6C2-CWZ6C

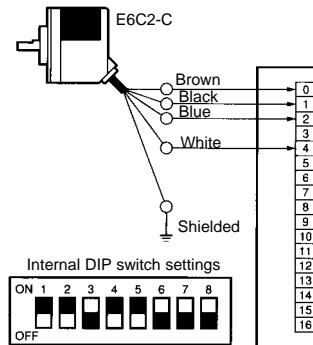



■ C200H-CT□□ HIGH-SPEED COUNTER UNIT

Applicable model: E6C2-CWZ6C  
 Typical model: C200H-CT001-V1

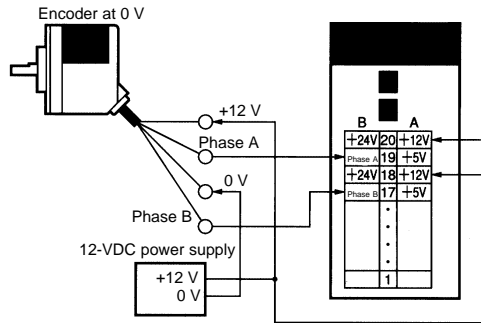

Note: Apply the following connections if the power supply to the E6C2-C is 5 or 24 V.  
 Phase A and power supply: 5 V to A19 and 24 V to B20  
 Phase B and power supply: 5 V to A17 and 24 V to B18

Applicable Model: E6C2-CWZ5B

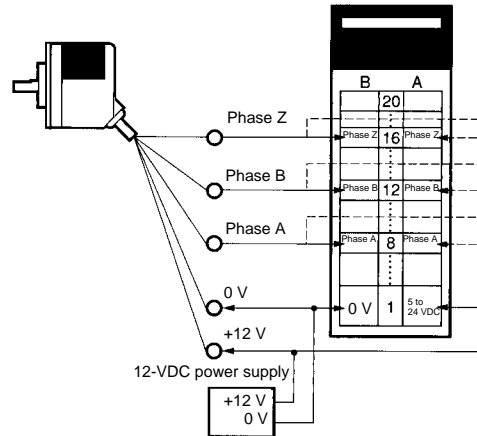

Note: Apply the following connections if the power supply to the E6C2-C is 12 or 24 V.  
 Phase A and power supply: 12 V to A8/B8 and 24 V A9/B9  
 Phase B and power supply: 12 V to A12/B12 and 24 to A13/B13  
 Phase Z and power supply: 12 V to A16/B16 and 24 V to A17/B17

■ CQM1-CPU43-EV1 (AS BUILT-IN HIGH-SPEED COUNTER)

The pulse output of the E6C2-C can be directly input into IN04, IN05, and IN06 of the CPU Unit to use these three points as a built-in high-speed counter.

The single-phase response speed is 5 kHz, and the two-phase response speed is 2.5 kHz. The count value is within a range between 0 and 65,535 in increment mode and -32,767 and 32,767 in decrement mode.

The operating mode of the high-speed counter is set with the PC Setup in the DM area.

Count Mode

Up/Down mode	Increment/decrement counter uses phases A and B.
Incrementing mode	Increment counter uses phase A only.
Normal mode	IN04 through IN06 are used for normal input.

Applicable Model: E6C2-CWZ6C

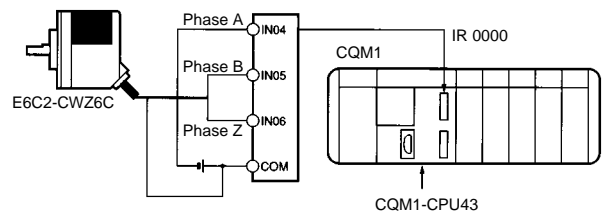

Reset

The present count value can be reset with the soft-reset function or the AND of soft reset and phase Z input.

Output

Target value	When the count value reaches the target value, the specified subroutine is executed. A maximum of 16 target values can be set.
Range comparison	When the count value is within the range, the specified subroutine is executed. A maximum of 8 ranges can be set with upper and lower limits.

# Precautions

## ■ AVOID DAMAGE OR MALFUNCTION

- Do not impose voltage exceeding the rated voltage range on the E6C2-C.
- Be sure that the wiring of power supply to the E6C2-C is correct.
- Turn off the Rotary Encoder when wiring.
- Do not wire power lines or high-tension lines along with the power supply lines of the E6C2-C Rotary Encoder.

## ■ MOUNTING

- Be careful not to spray water or oil onto the E6C2-C Rotary Encoder.
- The E6C2-C Rotary Encoder consists of high-precision components. To avoid malfunction, handle with extreme care and do not drop the Rotary Encoder.
- Do not pull the cable of the E6C2-C Rotary Encoder after the E6C2-C Rotary Encoder is mounted to a panel. Do not apply any shock to the hollow shaft or the body.
- When the E6C2-C Rotary Encoder is used in reversed operation, pay utmost attention to the mounting direction of the E6C2-C Rotary Encoder and the directions of increment and decrement rotation.
- To match phase Z of the E6C2-C Rotary Encoder and the origin of the device to be connected to the E6C2-C Rotary Encoder, the phase Z outputs must conform while connecting the device.
- Be careful not to impose an excessive load on the shaft if the shaft connects to a gear.
- If the Rotary Encoder is mounted with screws, the tightening torque must be approximately 5 kgf • cm (0.49 N • m) 0.36 ft lbf.
- If the Rotary Encoder is mounted to a panel, do not pull the cable with more than a force of 3 kgf (29.4 N) 6.61 lbf.

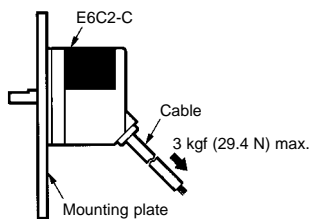

- No shock must be given to the shaft or coupling. Do not hit the shaft or coupling with a hammer when inserting the shaft into the coupling.

Refer to the following illustrations when using a standard coupling.

Decentering tolerance	
Declination tolerance	
Displacement tolerance in the shaft direction	

When connecting or disconnecting the coupling, do not impose an excessive bending, pressing, or pulling force on the E6C2-C.

When connecting the shaft of the Rotary Encoder with a chain timing belt or gear, connect the chain timing belt or gear with the shaft via the bearing and coupling as shown in the following illustration.

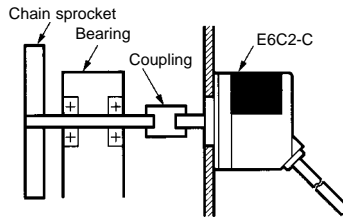

If the decentering or declination value exceeds the tolerance, an excessive load imposed on the shaft may damage the Rotary Encoder or shorten the life of the Rotary Encoder.

## Bearing Life

The following graph shows the life expectancy of the bearing with radial and thrust loads imposed on the bearing. (Theoretical)

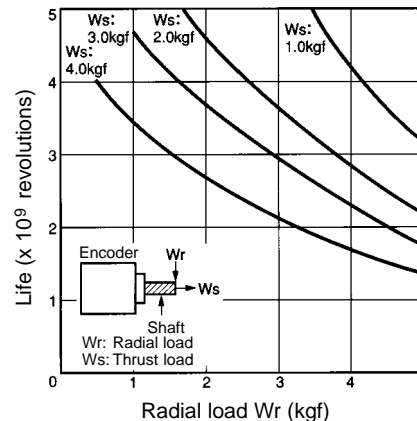

### Mounting Procedure

1. Insert the shaft into the coupling.

Do not secure the coupling and shaft with screws at this stage.

2. Secure the Rotary Encoder.

Refer to the following table for the maximum insertion length of the shaft into the coupling.

Part number	Maximum insertion length
E69-C06B	5.5 mm (0.22)
E69-C06M	8.5 mm (0.33)

3. Secure the coupling.

Part number	Tightening torque
E69-C06B	2.5 kgf • cm (0.25 N • m) 0.18 ft lbf
E69-C06M	7 kgf • cm (0.7 N • m) 0.52 ft lbf

4. Connect the power and I/O lines.

Be sure to turn off the Rotary Encoder when connecting the lines.

5. Turn on the Rotary Encoder and check the output.

### CONNECTING

- When extending the cable, select the type carefully. You must consider the response frequency because the longer the cable is, the more the residual voltage increases due to the resistance of the cable and the capacitance between the wires. As a result, the waveform will be distorted.
- We recommend the line driver output type model if the cable needs to be extended.
- In order to reduce inductive noise, the cable must be as short as possible, especially when the signal is input to an IC.
- Insert a surge absorber between the power supply terminals if a possibility of surge exists.
- A wrong pulse may be generated when the E6C2-C Rotary Encoder is turned on or off. Do not use the connected device for 0.1 s after the E6C2-C Rotary Encoder is turned on and for 0.1 s before the E6C2-C Rotary Encoder is turned off.

#### Cable Extension

- The rise time of each output waveform will increase when the cable is extended. This affects the phase difference characteristics of phases A and B.
- The available length of cable varies with the response frequency and noise. It is safer to limit the length of cable to 10 m maximum. If a longer cable of up to 100 m is required, use line driver output.

Note: Recommended cable:

Cross section: 0.2 mm<sup>2</sup> with spiral shield  
 Conductor resistance: 92 Ω/km max. at 20°C  
 Insulation resistance: 5 MΩ/km min. at 20°C

- The rise time varies with the resistance of the cable and the type and length of the cable.
- The residual output voltage will increase according to the length of the cable.

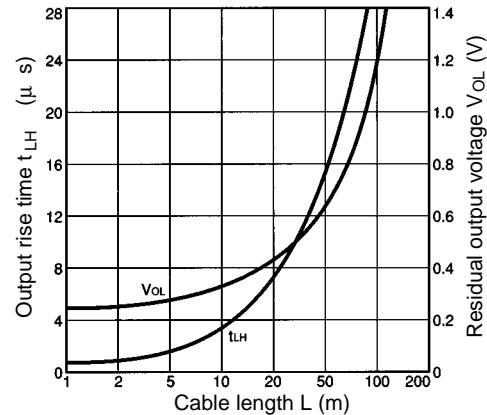

#### Conditions

Rotary Encoder: E6C2-CWZ6C

Load voltage: 5 VDC

Load resistance: 1 kΩ (The residual output voltages were measured with a load current of 35 mA.)

Cable: Dedicated cable

### PREVENTING MISCOUNTING

- If the operation of the E6C2-C Rotary Encoder is stopped near a signal rising or falling edge, a wrong pulse may be generated, causing the E6C2-C Rotary Encoder to miscount. In this case, use an increment-decrement counter to prevent miscounting.

### EXTENSION OF LINE DRIVER OUTPUT

- Be sure to use a twisted-pair cable to extend a line driver cable. Use an RS-422A receiver for the receiver side.
- The twisted-pair wires as shown in the following illustration are suitable for RS-422A signal transmission. Normal mode noise can be eliminated by twisting the wires because the generated electrical forces on the lines cancel each other.

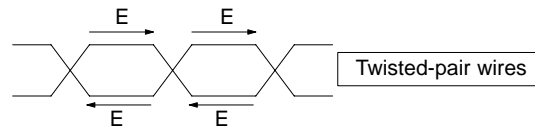

- Be sure the E6C2-C Rotary Encoder is supplied with 5 VDC when a line driver output is used. There will be approximately a 1-V voltage drop if the cable length is 100 m.

**NOTE: DIMENSIONS SHOWN ARE IN MILLIMETERS. To convert millimeters to inches divide by 25.4.**

---

**OMRON**<sup>®</sup>

**OMRON ELECTRONICS, INC.**

One East Commerce Drive  
Schaumburg, IL 60173

**1-800-55-OMRON**

**OMRON CANADA, INC.**

885 Milner Avenue  
Scarborough, Ontario M1B 5V8

**416-286-6465**