

3A Avg.

30 Volts

SBD

EA30QS03L

■最大定格 Maximum Ratings

Item	Symbol	Conditions	Unit	
くり返しピーク逆電圧 Repetitive Peak Reverse Voltage	$V_{RRM}$	30	V	
平均整流電流 Average Rectified Forward Current	$I_O$	50Hz、正弦半波通電抵抗負荷 50Hz Half Sine Wave Resistive Load	$T_a=32^{\circ}C^*$ $T_c=126^{\circ}C$	1.7 3.0 A
実効順電流 R.M.S. Forward Current	$I_F(RMS)$	4.71	A	
サージ順電流 Surge Forward Current	$I_{FSM}$	45 50Hz正弦半波、1サイクル、非くり返し 50Hz Half Sine Wave, 1cycle, Non-repetitive	A	
動作接合温度範囲 Operating Junction Temperature Range	$T_{jw}$	-40~+150	$^{\circ}C$	
保存温度範囲 Storage Temperature Range	$T_{stg}$	-40~+150	$^{\circ}C$	

■OUTLINE DRAWING(mm)

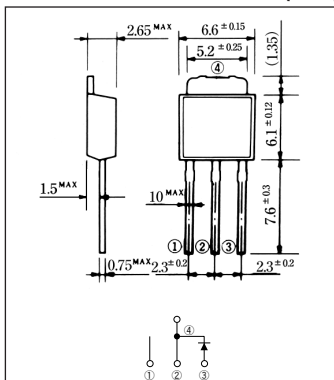

■APPROX. NET WEIGHT:0.35g

■電氣的・熱的特性 Electrical/Thermal Characteristics

Item	Symbol	Conditions	Min.	Typ.	Max.	Unit
ピーク逆電流 Peak Reverse Current	$I_{RM}$	$T_j=25^{\circ}C, V_{RM}=V_{RRM}$	—	—	3	mA
ピーク順電圧 Peak Forward Voltage	$V_{FM}$	$T_j=25^{\circ}C, I_{FM}=3A$	—	—	0.45	V
熱抵抗 Thermal Resistance	$R_{th(j-a)}$	接合部・周囲間 Junction to Ambient	—	—	80	$^{\circ}C/W$
	$R_{th(j-c)}$	接合部・ケース間 Junction to Case	—	—	6	$^{\circ}C/W$

\* P.C.Board mounted Print Land=20×20mm

■定格・特性曲線

