

Keypad board datasheet EB014-00-1



Contents

1.	About this document	2
2.	General information	3
3.	Board layout	4
4.	Testing this product.....	5
5.	Circuit description	6

Appendix 1 Circuit diagram

1. About this document

This document concerns the E-blocks Keypad board code EB014 version 1.

The order code for this product is EB014.

1. **Trademarks and copyright**

PIC and PICmicro are registered trademarks of Arizona Microchip Inc.
E-blocks is a trademark of Matrix Multimedia Limited.

2. **Other sources of information**

There are various other documents and sources that you may find useful:

Getting started with E-Blocks.pdf

This describes the E-blocks system and how it can be used to develop complete systems for learning electronics and for PICmicro programming.

PPP Help file

This describes the PPP software and its functionality. PPP software is used for transferring hex code to a PICmicro microcontroller.

C and assembly strategies

This is available as a free download from our web site.

3. **Disclaimer**

The information in this document is correct at the time of going to press. Matrix Multimedia reserves the right to change specifications from time to time. This product is for development purposes only and should not be used for any life-critical application.

4. **Technical support**

If you have any problems operating this product then please refer to the troubleshooting section of this document first. You will find the latest software updates, FAQs and other information on our web site: www.matrixmultimedia.com . If you still have problems please email us at: support@matrixmultimedia.co.uk.

2. General information

1. Description

A simple 4x3 keyboard that allows data entry into bus based systems. Flowcode macros for driving this E-block are available.

2. Features

- 4 by 3 keypad for E-blocks
- Flowcode macros available

3. Block schematic

Not supplied.

3. Board layout



EB015-74-1.cdr

- 1) 9 Way D-type Plug
- 2) Matrixed 3x4 data keypad

4. Testing this product

The following program will test the circuit. The test file can be downloaded from www.matrixmultimedia.com.

1. System Setup

Multi-programmer board (EB006) with:

EB006 Options	Setting
Power supply	External, 14V
PICmicro device	16F877A
SW1 (Fast/Slow)	Don't care
SW2 (RC/Xtal)	Xtal
Xtal frequency	19.6608MHz
Port A	LED board EB004
Port B	Keypad board EB014
Port C	
Port D	
Port E	
Test program	keypad.hex

2. Test Procedure

- 1) Wire power to all boards.
- 2) Configure system and board options as above.
- 3) Download the test program to the Multiprogrammer
- 4) Press each button on the Keypad Board and check that the binary value of that Keypad number illuminates on the LED Board
- 5) For example pressing keypad button 5 will illuminate “(MSB) 0 0 0 0 0 1 0 1 (LSB)”
 1. The * button on the keypad represents the number 10
 2. The # button on the keypad represents the number 11

5. Circuit description

1. *Description*

The circuit board consists of 7 digital I/O lines on a 'downstream' 9-way D-type plug. This routes each bit to a particular line of the keypad. Columns 1, 2 and 3 are routed to bits 0, 1, and 2 respectively. Rows 1, 2, 3 and 4 are routed to bits 5, 6, 7 and 8 respectively. These values were chosen to enable the use of interrupts when connecting the keypad to Port B.

The diagram below shows the internal characteristics of the Keypad.

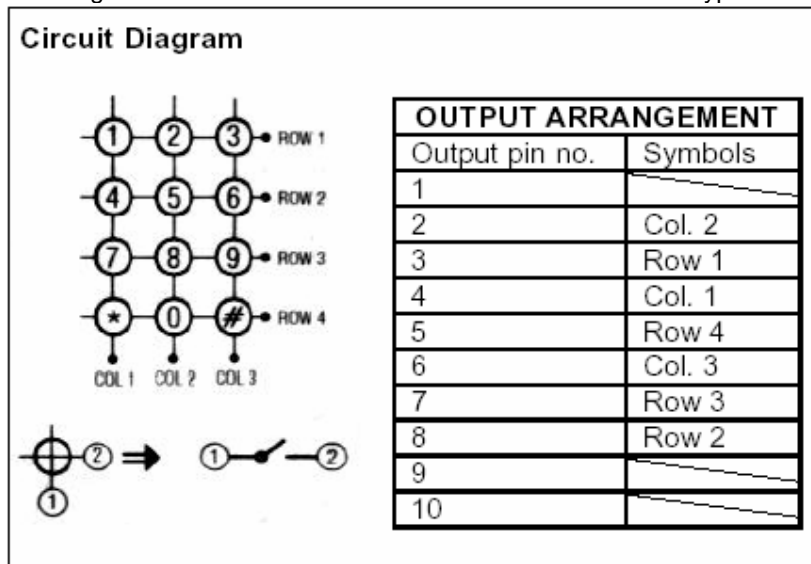

2. *3.3V operation*

This board is compatible with upstream boards operating off 3.3V.

Appendix 1 – Circuit diagram

THIS SYSTEM INCLUDES:-

→ FEET

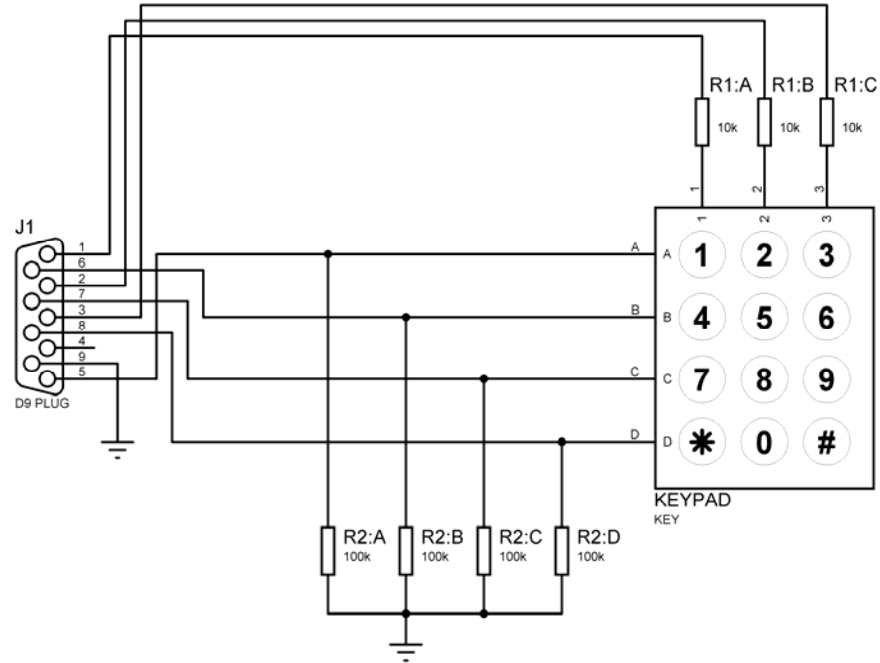

Keypad Ref. No.	Keypad Pinout	Column / Row
1	4	Col 1
2	2	Col 2
3	6	Col 3
A	3	Row 1
B	8	Row 2
C	7	Row 3
D	5	Row 4

		MATRIX MULTIMEDIA LTD. www.matrixmultimedia.co.uk (c) Copyright 2004 Matrix Multimedia	
TITLE: Keypad Board EB-014-00-1		DATE: 04/05/04 PAGE: 1/1	
BY: Conor Carr		REV: 1.0	