

# EBLOCKS<sup>®</sup>

Keypad board



# Contents

|                     |   |
|---------------------|---|
| About this document | 3 |
| Board layout        | 3 |
| General information | 4 |
| Circuit description | 4 |
| Protective cover    | 5 |
| Circuit diagram     | 6 |

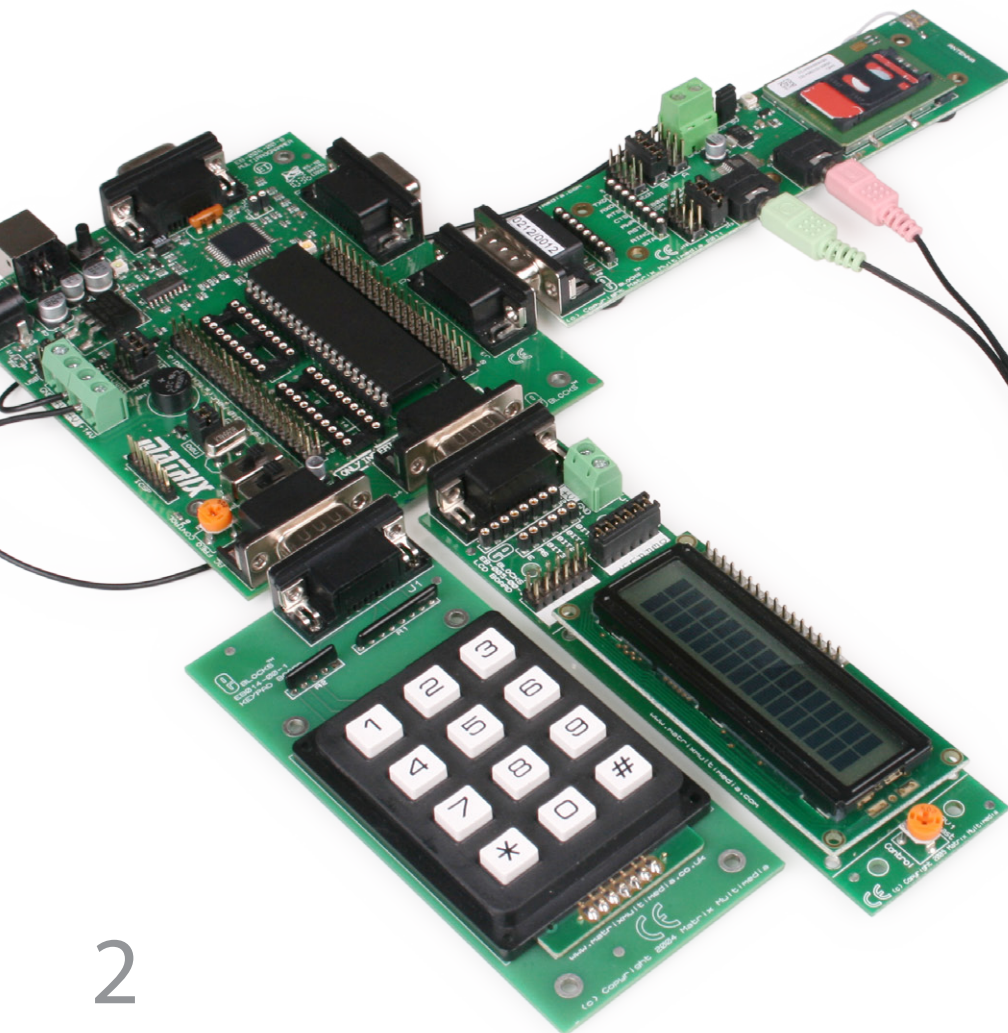

# About this document

This document concerns the EB0014 E-blocks keypad board.

## 1. Trademarks and copyright

PIC and PICmicro are registered trademarks of Arizona Microchip Inc. E-blocks is a trademark of Matrix Multimedia Ltd.

## 2. Disclaimer

The information provided within this document is correct at the time of going to press. Matrix Multimedia reserves the right to change specifications from time to time.

## 3. Testing this product

It is advisable to test the product upon receiving it to ensure it works correctly. Matrix provides test procedures

for all E-blocks, which can be found in the Support section of the website.

## 4. Product support

If you require support for this product then please visit the Matrix website, which contains many learning resources for the E-blocks series. On our website you will find:

- How to get started with E-blocks - if you are new to E-blocks and wish to learn how to use them from the beginning there are resources available to help.
- Relevant software and hardware that allow you to use your E-blocks product better.
- Example files and programs.
- Ways to get technical support for your product, either via the forums or by contacting us directly.

# Board layout

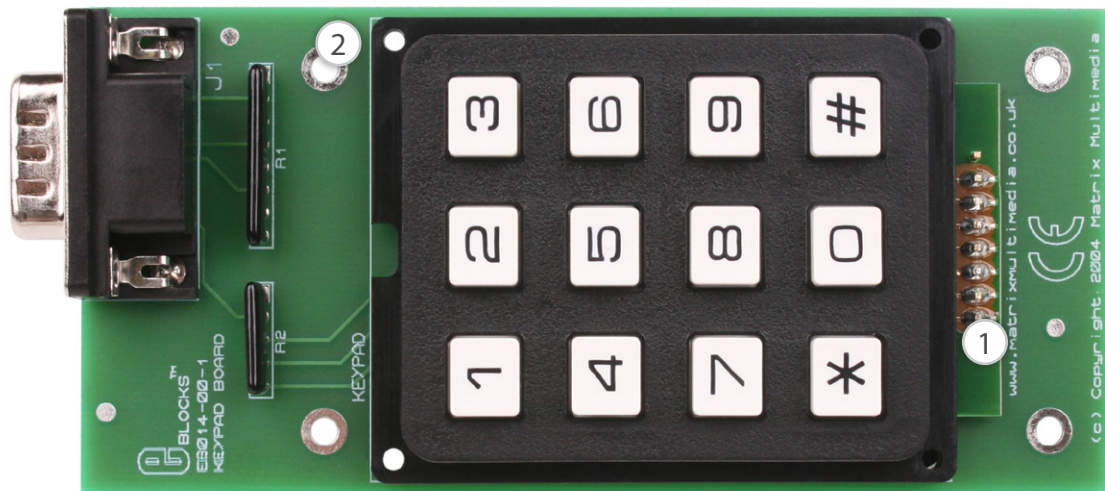

1. 9-way D-type plug
2. 3 x 4 data keypad matrix

# General information

A simple 4 x 3 keyboard that allows data entry into bus based systems. Flowcode macros for driving this E-block are available.

1. Features
  - 4 x 3 keypad for E-blocks
  - Flowcode macros available

## Circuit description

The EB014 keypad board circuit can be observed on page 6.

### 1. Description

The circuit board consists of 7 digital I/O lines on a 'downstream' 9-way D-type plug, this routes each bit to a particular line of the keypad. Columns 1, 2 and 3 are routed to bits 0, 1 and 2 respectively. Rows 1, 2, 3 and 4 are routed to bits 5, 6, 7 and 8 respectively. These values

were chosen to enable the use of interrupts connecting the keypad to Port B.

The diagram below shows the internal characteristics of the keypad.

### 2. 3.3V operation

This board is compatible with upstream boards operating off 3.3V.

Circuit diagram

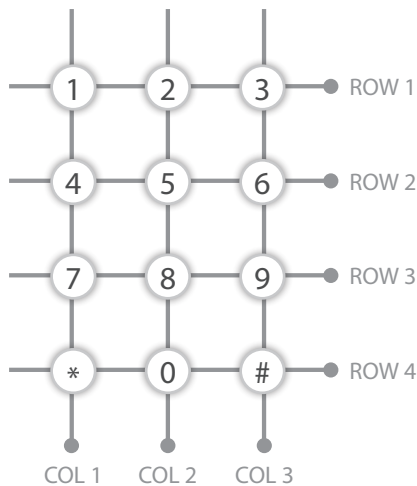

| Output arrangement |         |
|--------------------|---------|
| OUTPUT PIN NO.     | SYMBOLS |
| 1                  |         |
| 2                  | Col. 2  |
| 3                  | Row 1   |
| 4                  | Col. 1  |
| 5                  | Row 4   |
| 6                  | Col. 3  |
| 7                  | Row 3   |
| 8                  | Row 2   |
| 9                  |         |
| 10                 |         |

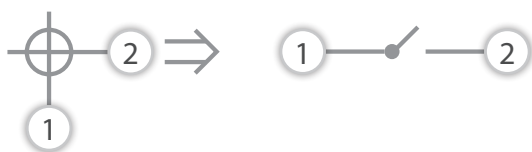

# Protective cover

Most of the boards in the E-blocks range can be fitted with a plastic cover as an optional extra. These covers are there to protect your E-blocks board therefore extending the life of the board. The covers also prevent the removal of external components while still allowing for the adjustment of applicable parts on the board.

12mm M3 spacers, anti-slip M3 nuts and 25mm M3 bolts can be used to attached the cover to the board. These are not included but can be bought separately from our website.

The order code for the EB014 keypad board is EB714.

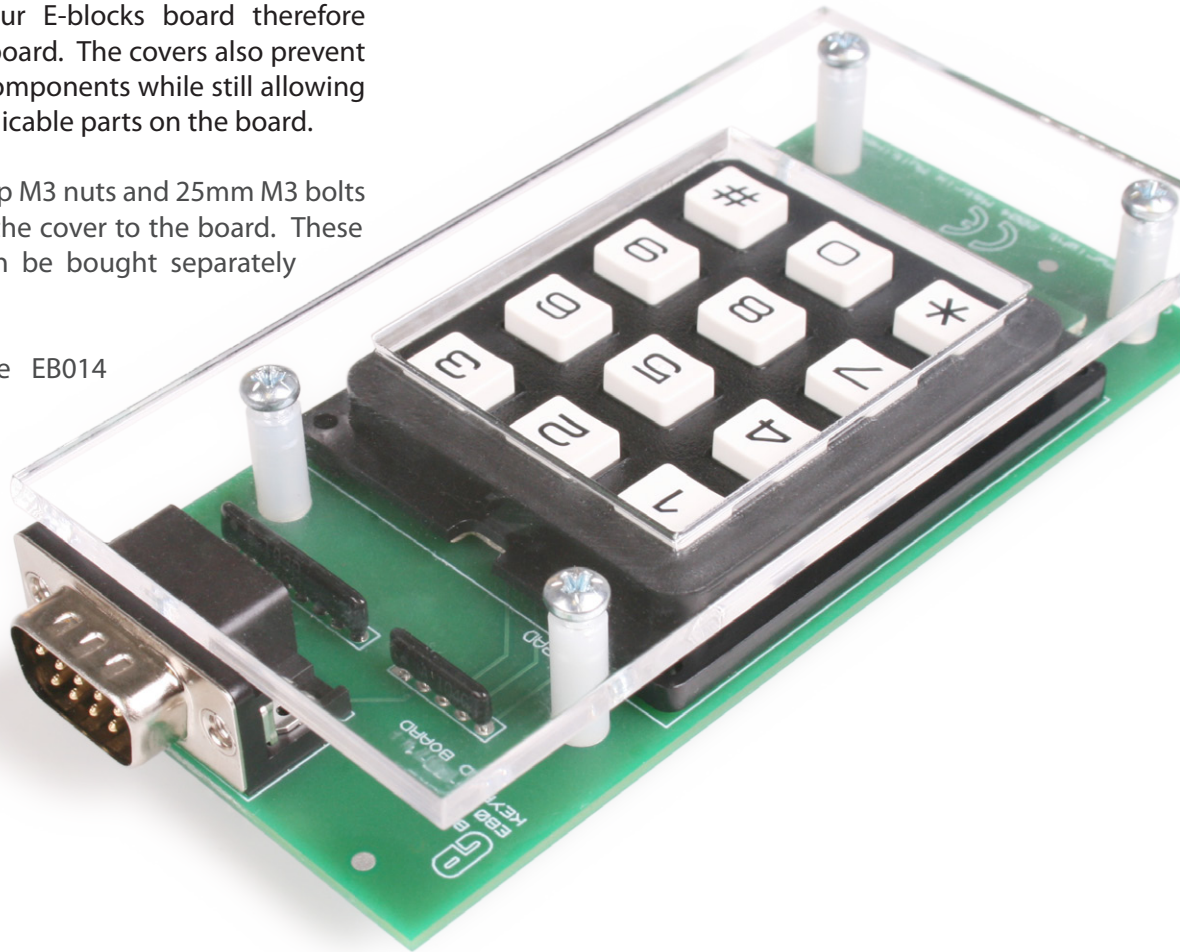

# Circuit diagram

THIS SYSTEM INCLUDES:-

- F1 FEET
- F2 FEET
- F3 FEET
- F4 FEET
- F5 FEET
- B1 BAG
- L1 LABEL
- BUILD

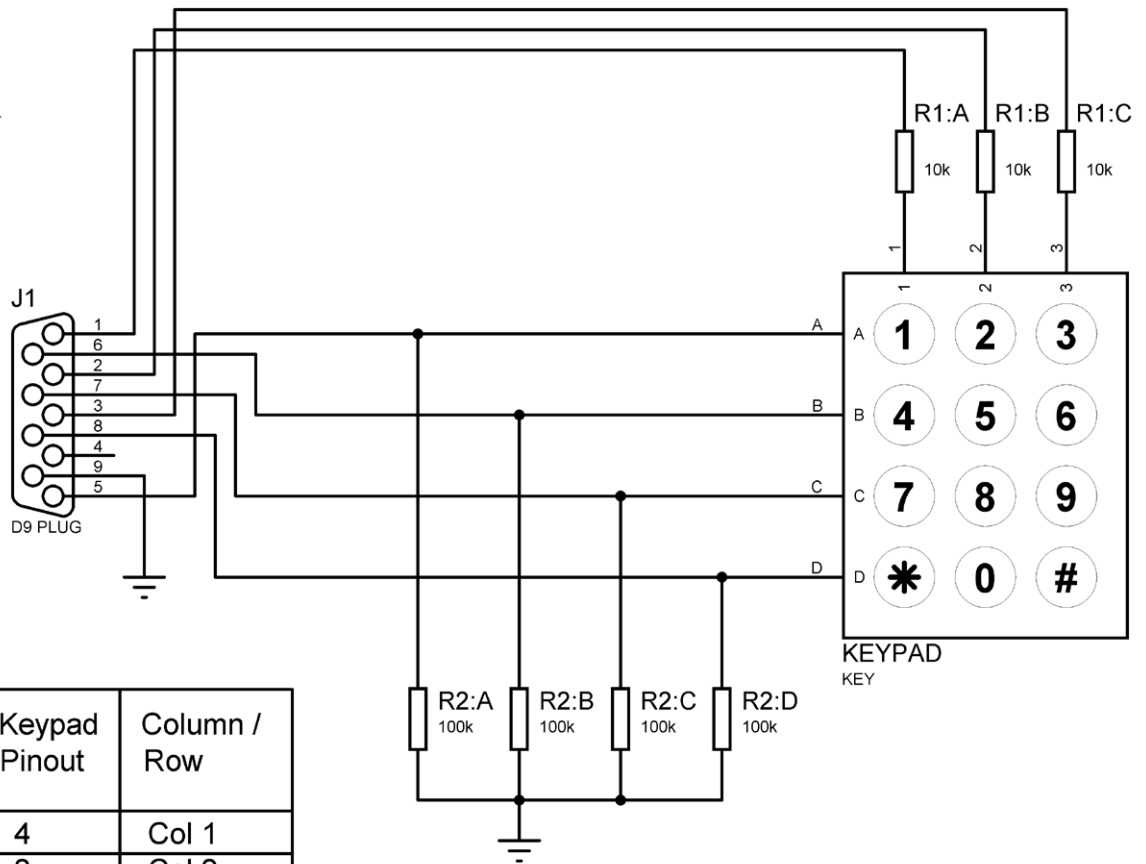

| Keypad Ref. No. | Keypad Pinout | Column / Row |
|-----------------|---------------|--------------|
| 1               | 4             | Col 1        |
| 2               | 2             | Col 2        |
| 3               | 6             | Col 3        |
| A               | 3             | Row 1        |
| B               | 8             | Row 2        |
| C               | 7             | Row 3        |
| D               | 5             | Row 4        |