

EB35W1M Bluetooth Stereo Audio Module

Product Description

The EB35W1M Bluetooth stereo audio module is based on CSR BC05 chip BC57E687. The module has been integrated with most of the peripheral components and fully tuned to obtain best RF and audio performance, thus make it a simple plug and play solution for Bluetooth products design. This mass production proven module helps OEM customers to achieve high yield rate and reduce the time to market.

EB35W1M is compliant with Bluetooth V2.0+EDR, and supports A2DP, AVRCP, HS, HF profiles, it mainly targets on Bluetooth stereo applications like Bluetooth speakers, Car-kits, it has been designed with the stereo application specified requirements in mind. The embedded Kalimba DSP enables sound effects as echo cancelation, noise cancelation, SRS sound functions. The module also features a UART connection to let the master MCU to have the full access of the Bluetooth functions.

Applications

- Stereo Speakers
- Stereo Headsets
- Stereo Car-kits
- Stereo Audio Dongles
- Microphones

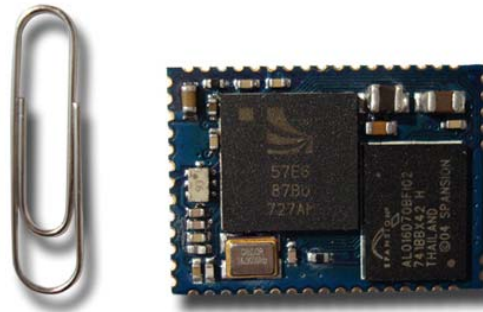

Features

- Complete Stereo Bluetooth Function Module
- Based on CSR BC05 chip BC57E687
- Compliant with Bluetooth V2.0+EDR
- Built-in Battery Charger
- Built-in 1.8V DC/DC Converter
- Highly integrated, small form factor
- Class 2 RF with range up to 15m
- Embedded DSP for sound processing support
- Full Bluetooth functions through UART control
- High performance Integrated 16 bit codec for Stereo input and output
- Flexible design, custom functions supported

Electrical Specification

	Description	Min/Typical/Max
General	Supply voltage	3.3V
	Supply current	45mA
	Audio Format	SBC
	Operation temperature	-10 ~ +60°C
RF	RF Frequency	2400 ~ 2483MHZ
	RF Channels	79 Channels
	Bluetooth Spec.	V2.0+EDR
	Output Power Class	Class 2
	TX Power	0dBm / +6dBm
	RX Sensitivity	-90dBm
Audio	Input level	1.0Vrms
	Input impedance	10K Ohm
	Output level	1.0Vrms
	Output impedance	1K Ohm
	Frequency response	20Hz ~ 20KHz(-3dB)
	Latency	200ms, Configurable
	Sampling accuracy	44.1KHz, 16bit
	S/N ratio	85dB
	THD	<0.1% @ 1KHz
	Dynamic range	82dB
	Channel separation	65dB

Table [1]: Electrical Specification

Pin Assignments

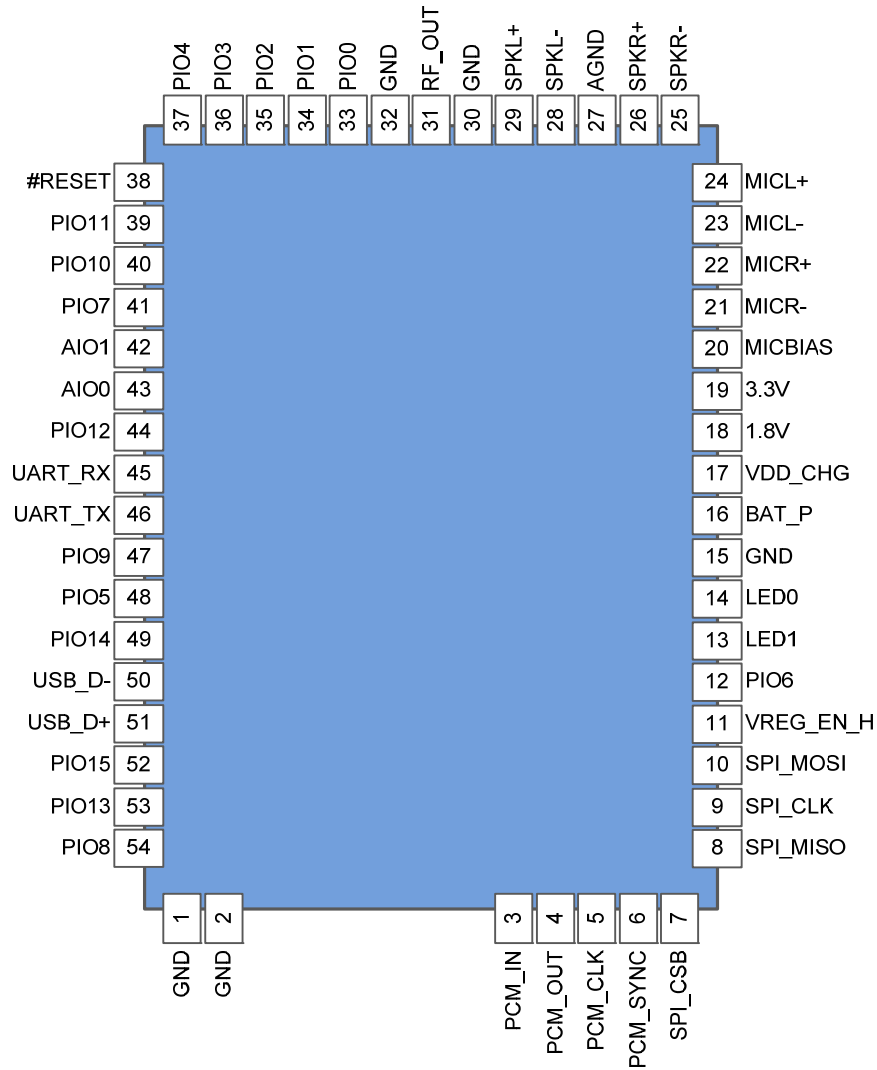

Figure [1]: Pin out

Pin #	Pin name	Type	Description
1	GND	P	Ground power
2	GND	P	Ground power
3	PCM_IN	I	Synchronous data input
4	PCM_OUT	O	Synchronous data output
5	PCM_CLK	I/O	Synchronous data clock
6	PCM_SYNC	I/O	Synchronous data sync
7	SPI_CSB	I/O	Chip select for SPI bus, active low

8	SPI_MISO	I/O	SPI data out
9	SPI_CLK	I/O	SPI clock
10	SPI_MOSI	I/O	SPI data in
11	VREG_EN_H	I	High Voltage Regulator Enable Input, 1 to enable
12	PIO6	I/O	General purpose I/O
13	LED1	O	LED driver, Open drain output
14	LED0	O	LED driver, Open drain output
15	GND	P	Ground Power
16	BAT_P	O	Lithium ion/polymer battery positive terminal. Battery charger output and input to switch-mode regulator
17	VDD_CHG	I	Lithium ion/polymer battery charger input
18	1.8V	P	1.8V DC output
19	3.3V	P	3.3V DC input
20	MICBIAS	A	Microphone bias
21	MICR-	A	Microphone input negative, right
22	MICR+	A	Microphone input positive, right
23	MICL-	A	Microphone input negative, left
24	MICL+	A	Microphone input positive, left
25	SPKR-	A	Speaker output negative, right
26	SPKR+	A	Speaker output positive, right
27	AGND	P	Audio GND
28	SPKL-	A	Speaker output negative, left
29	SPKL+	A	Speaker output positive, left
30	GND	P	Ground Power
31	RF_OUT	A	RF signal output
32	GND	P	Ground Power
33	PIO0	I/O	General purpose I/O
34	PIO1	I/O	General purpose I/O
35	PIO2	I/O	General purpose I/O
36	PIO3	I/O	General purpose I/O
37	PIO4	I/O	General purpose I/O
38	#RESET	I	Reset, active low
39	PIO11	I/O	General purpose I/O
40	PIO10	I/O	General purpose I/O
41	PIO7	I/O	General purpose I/O
42	AIO1	I/O	Analog programmable I/O
43	AIO0	I/O	Analog programmable I/O

44	PIO12	I/O	General purpose I/O
45	UART_RX	I	UART data input
46	UART_TX	O	UART data output
47	PIO9	I/O	General purpose I/O
48	PIO5	I/O	General purpose I/O
49	PIO14	I/O	General purpose I/O
50	USB_D-	I/O	USB data input negative
51	USB_D+	I/O	USB data input positive
52	PIO15	I/O	General purpose I/O
53	PIO13	I/O	General purpose I/O
54	PIO8	I/O	General purpose I/O

Table [2]: Pin assignments

Physical Dimension

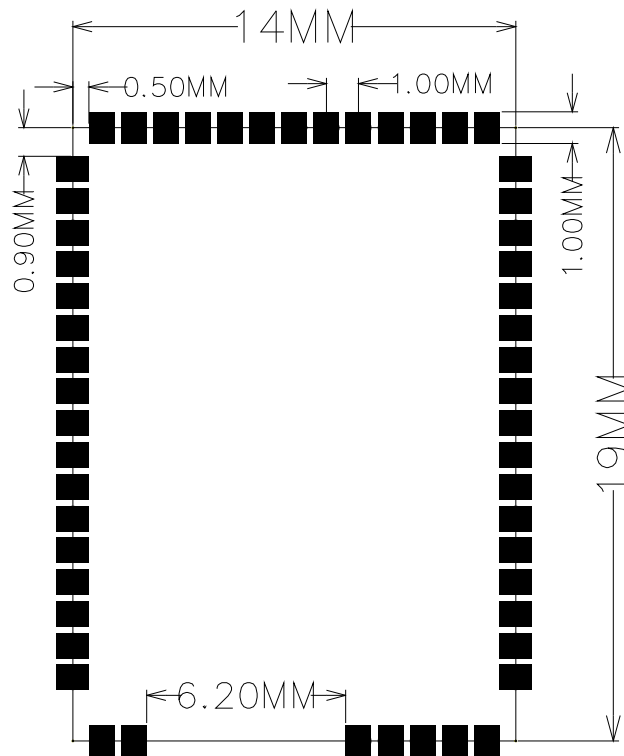

Figure[2]: Dimensions

Application Circuit

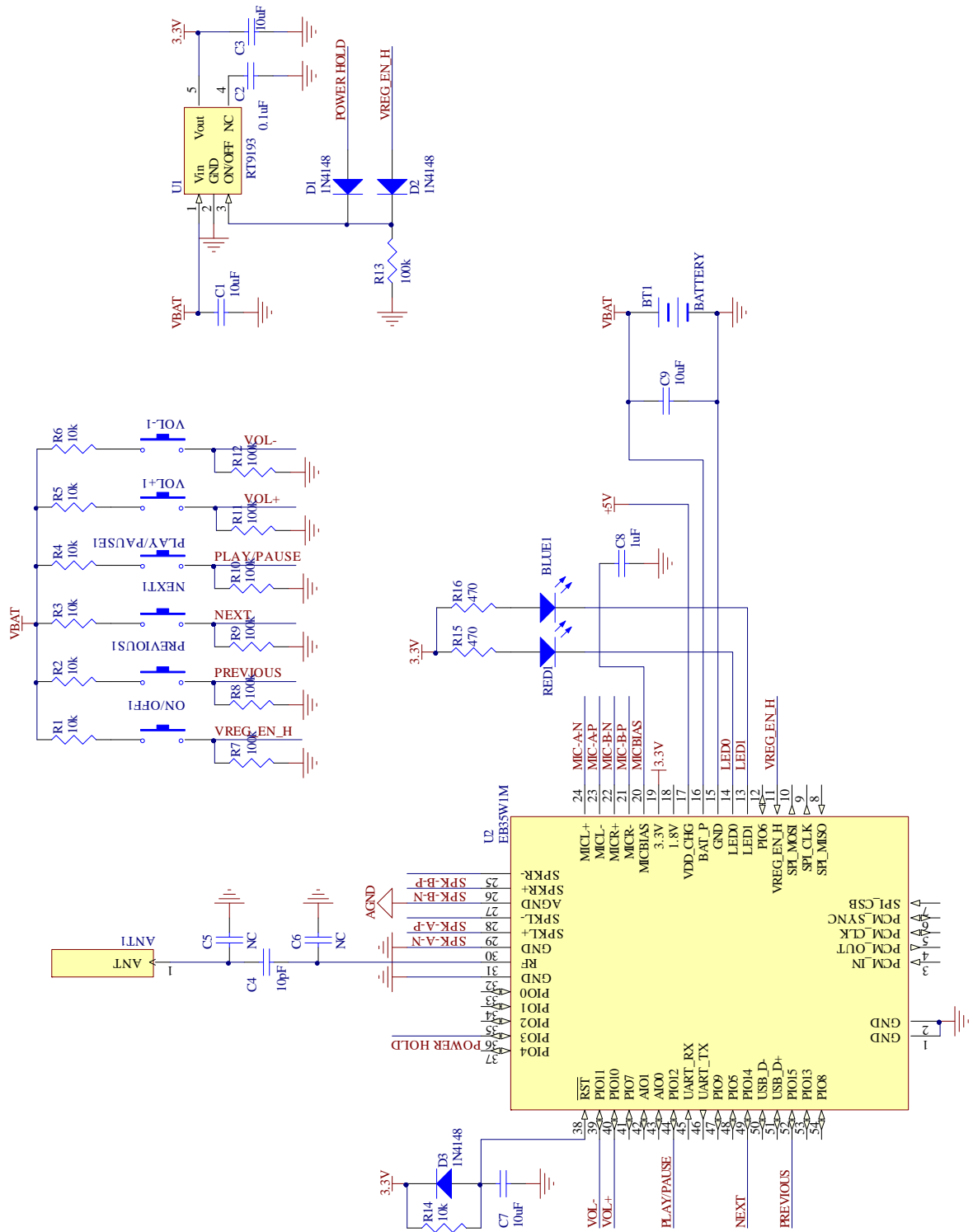

Figure[3]: Application Schematic(With Battery)

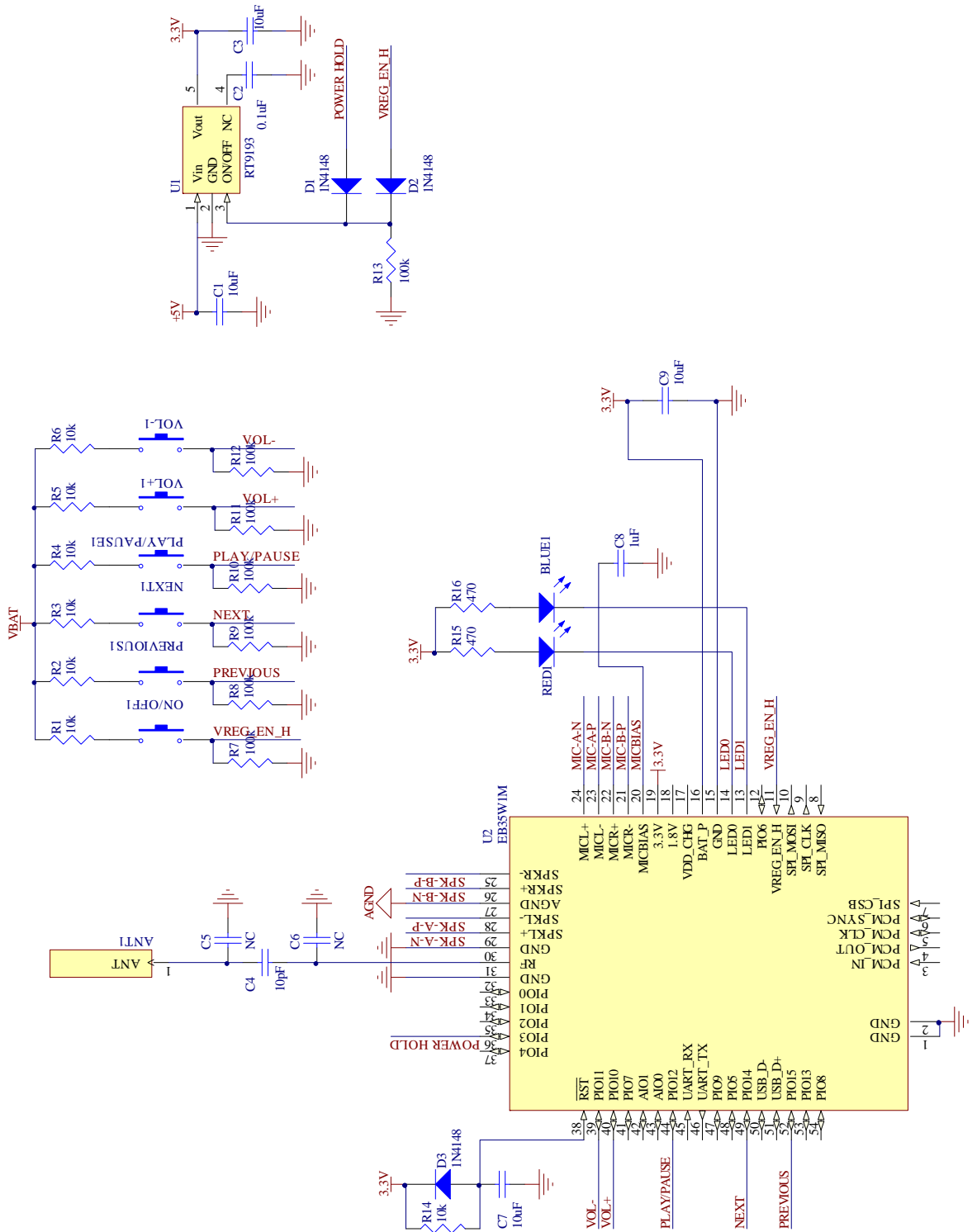

Figure[4]: Application Schematic(Without Battery)

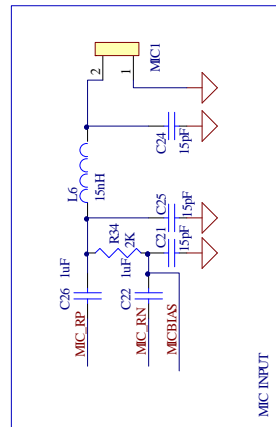
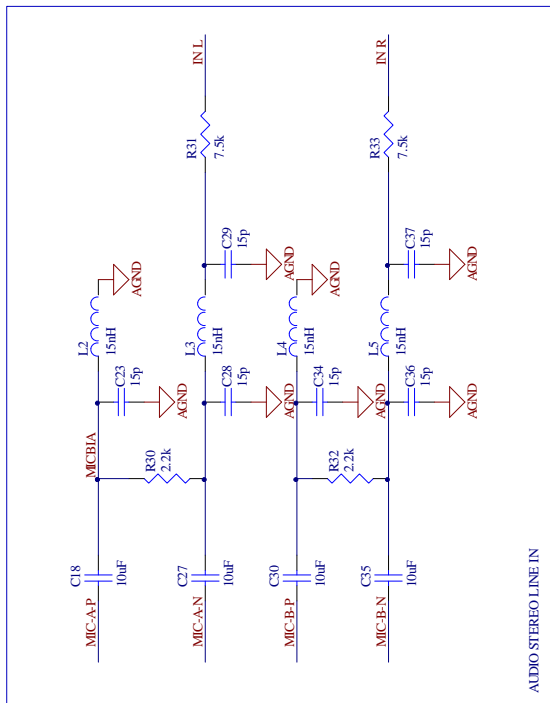
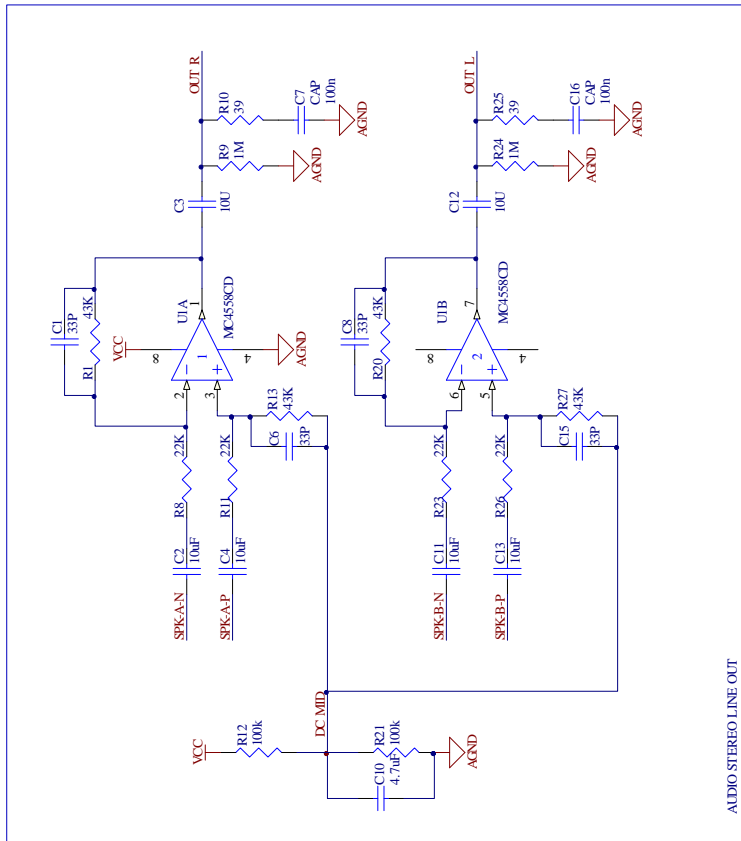

Figure[5]: Application Schematic

Ordering Information

Gigawit ID.	Description
EB35W1M	Bluetooth Stereo based on CSR BC05 chip BC57E687BEU

Contact

捷电科技有限公司 Gigawit Electronics Limited
1003 Overseas Scholars Building, South Keyuan Road
Science Park, Nanshan District, 518057 Shenzhen, China
Tel:+86-755-86329300, Fax:+86-755-86329882
<http://www.gigawit.com>

Revision History

2007-12-12 Version 1.0, Original version
2008-10-10 Version 1.1, Update W1M Pin outs and the application schematic