

USER'S GUIDE

www.DataSheet4U.com

CODEC-5.1 Daughtercard

**February 2003
Engineering Draft**

This document is an engineering draft. Because of an overriding need to get this information to the customer quickly, this document may not have been reviewed for technical content, clarity, organization, or accuracy. This document may not have been edited for spelling, grammar, and punctuation. This document may not be in LSI Logic standard document, page, paragraph, or table formats, and may not have cross references to or from other documents.

This document contains proprietary information of LSI Logic Corporation. The information contained herein is not to be used by or disclosed to third parties without the express written permission of an officer of LSI Logic Corporation.

Document number DB15-000281-00, February 2003

This document describes the version of LSI Logic Corporation's Codec 5.1 Daughter Card and will remain the official reference source for this product until rescinded by an update.

www.DataSheet4U.com

To receive other ZSP-related product literature, visit us at <http://www.zsp.com>.

LSI Logic Corporation reserves the right to make changes to any products herein at any time without notice. LSI Logic does not assume any responsibility or liability arising out of the application or use of any product described herein, except as expressly agreed to in writing by LSI Logic; nor does the purchase or use of a product from LSI Logic convey a license under any patent rights, copyrights, trademark rights, or any other of the intellectual property rights of LSI Logic or third parties.

Copyright © 2002-2003 by LSI Logic Corporation. All rights reserved.

TRADEMARK ACKNOWLEDGMENT

LSI Logic, the LSI Logic logo design and ZSP are trademarks or registered trademarks of LSI Logic Corporation. All other brand and product names may be trademarks of their respective companies.

Preface

This book is the primary reference for the CODEC-5.1 daughtercard. It contains detailed descriptions of the Card's features, design and how to use it with the EB402 and EB403 evaluation boards.

Audience

This document assumes that you have some familiarity with micro and/or digital signal processors and digital and analog audio electronics. The people who benefit from this book are:

- Engineers who are using the CODEC-5.1 card in conjunction with the EB402 and EB403 ZSP™ processor evaluation boards.

Organization

This document has the following chapters and appendixes:

- [Chapter 1, "Introduction"](#) provides an overview of the CODEC-5.1 card and its features.
- [Chapter 2, "Installation,"](#) describes how to install the CODEC-5.1 card on an EB402 or EB403.
- [Chapter 3, "Operation,"](#) describes the interfaces between the CODEC-5.1 card and the EB402/EB403 boards, and describes the operation of the CODEC-5.1 circuitry.

Related Publications

The following documents are available from LSI Logic Corporation.

- LSI402ZX User's Guide

Engineering Draft

- LSI403LP User's Guide
- LSI EB402 User's Guide
- LSI EB403 User's Guide
- EB402 Board Support Package Technical Manual
- EB403 Board Support Package Technical Manual

This document is intended to provide information to help the reader install and use the CODEC-5.1 board to AKM Corporation AK4586 DataSheet <http://www.akm.com/datasheets/ek4586.pdf>

Conventions Used in This Manual

www.DataSheet4U.com

The first time a word or phrase is defined in this manual, it is *italicized*.

The word *assert* means to drive a signal true or active. The word *deassert* means to drive a signal false or inactive. Signals that are active LOW end in an "n."

Hexadecimal numbers are indicated by the prefix "0x" —for example, 0x32CF. Binary numbers are indicated by the prefix "0b" —for example, 0b0011.0010.1100.1111.

Contents

Chapter 1

Introduction

1.1	Introduction	1-1
1.2	Product Features	1-2

www.DataSheet4U.com

Chapter 2

Installation

2.1	Hardware Equipment Required	2-1
2.2	Hardware Setup for the CODEC-5.1 Daughtercard	2-2
2.3	Installation	2-2

Chapter 3

Operation

3.1	Interface to LSI402ZX/LSI403LP	3-1
3.2	Circuit Description	3-2

Appendix A

Schematics

Chapter 1

Introduction

This section introduces the features of the CODEC-5.1 card and describes the purpose for which it has been designed. It contains the following sections:

- [Section 1.1, "Introduction," page 1-1,](#)
- [Section 1.2, "Product Features," page 1-2.](#)

www.DataSheet4U.com

1.1 Introduction

This document is the primary reference and user's guide for the Multi-Channel Audio Codec (CODEC-5.1) daughtercard. This daughtercard interfaces with the LSI Logic ZSP400-based standard product evaluation boards, EB402 and EB403.

The daughtercard allows applications development for a 6-channel output codec for multi-channel audio applications. The codec used on board is an AKM AK4586, featuring 2x24-bit input channels, 6x24-bit output channels, with sampling rates up to 96KHz.

The daughtercard provides 6 line-level outputs. These outputs are available on both RCA-style connectors and 3.5mm phonojacks for ease of connecting to an external amplifier or powered speakers.

The daughtercard has 2 line-level analog inputs which support both RCA-style and a 35mm phonojack. In addition to these inputs, a separate 3.5mm phonojack input is connected to a circuit to support a Electret microphone input. A potentiometer is mounted on the board to adjust the gain of the microphone input circuit.

The analog section of the daughtercard can be powered from an external source for improved noise performance. For ease of use, the power

supplies can also be derived from the EB402/EB403 thus eliminating the need for separate power supplies.

The CODEC-5.1 daughtercard plugs into both of the SPORT connectors on the EB402 or EB403 evaluation board. All connections are made through the use of these 2 connectors.

This manual describes all the steps necessary to interface the CODEC-5.1 daughtercard to the LSI Logic ZSP processor evaluation boards (either EB402 or EB403).

1.2 Product Features

www.DataSheet4U.com

The CODEC-5.1 daughtercard provides the following features:

- AKM AK4586 codec chip
- SPDIF input
- SPDIF output
- 6 line-level output channels at 24-bits each
- 2 line-level input channels at 24-bits each
- Mono Electret microphone input
- Optional external power supplies for amplifiers
- Optional internal power supplies
- EB402/EB403 TDM serial port for data
- EB402/EB403 GPIO lines for configuration and control
- Interrupt lines to EB402/EB403

The codec analog outputs are limited to driving high-impedance loads. They should only be used to drive amplified speakers that accept line-level inputs. Do not connect passive, low-impedance (8 ohm) speakers to these outputs. The analog inputs must also be line-level signals.

The CODEC-5.1 is fully supported by the EB402 and EB403 Board Support Packages that are available as part of the LSI402ZX and LSI403LP Development Kits. Please refer to the *EB402 Board Support Package User Guide* or *EB403 Board Support Package User Guide* for further information.

Chapter 2

Installation

This chapter describes installation of the CODEC-5.1 card. It contains the following sections:

- [Section 2.1, "Hardware Equipment Required," page 2-1](#)
- [Section 2.2, "Hardware Setup for the CODEC-5.1 Daughtercard," page 2-2](#)
- [Section 2.3, "Installation," page 2-2](#)

www.DataSheet4U.com

2.1 Hardware Equipment Required

The following is the minimum recommended list of hardware required to evaluate and/or use the CODEC-5.1 daughtercard:

- LSI Logic EB402 or EB403 evaluation board.
- Host computer with SDK tools and debugger interface
- CODEC-5.1 Daughtercard
- Audio output devices
 - Line powered speakers, or
 - Amplifier with speakers, or
 - Analyzer
- Input Sources
 - DVD player or other SPDIF generating device
 - Stereo line-level inputs
 - Electret microphone

2.2 Hardware Setup for the CODEC-5.1 Daughtercard

The CODEC-5.1 daughtercard may be used with either the LSI Logic EB402 or the EB403 evaluation boards. The daughtercard is installed onto the SPORT0 and SPORT1 TDM interface connectors provided on the ZSP evaluation boards. [Figure 2.1](#) shows an illustration of the CODEC-5.1 indicating locations of the various connectors and jumpers on the board.

Figure 2.1 CODEC-5.1 Connectors

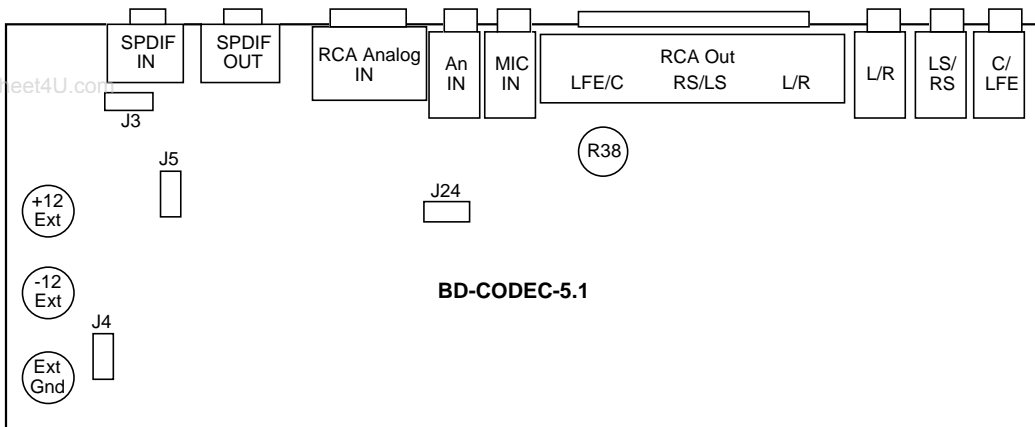

2.3 Installation

The installation procedure is as follows:

1. Set jumpers J3, J4, and J5 for either internal or external power as shown in [Table 2.1](#)

Table 2.1 Power connections

Jumper	Power from EB40X	External Power
J5	Open	Installed
J3	2-3	1-2
J4	2-3	1-2
J6	Open	Analog Ground
J7	Open	-12V DC (Acceptable range is -7Vdc to _15Vdc)
J8	Open	+12V DC (Acceptable range is +7Vdc to +15Vdc)

2. Install J24 for input selection as shown in [Table 2.2](#)

Table 2.2 Input Selection

Jumper	SPDIF Input	Stereo Line Input	Microphone Input
J24	2-3	2-3	1-2

3. Plug the CODEC-5.1 daughtercard into the motherboard. The connectors are keyed and can only be installed in one orientation.
4. Connect an external power source to the CODEC-5.1 daughtercard if configured from step 1. The external supply should be turned off during connection and only turned on after the connections have been made.
5. Connect an input source to one of the following locations as shown in [Table 2.3](#).

Table 2.3 Input Source Connector selection

Type	Input Connection - RCA	Input Connection - PhonoJack	Jumpers
Digital Audio	J19	NA	NA
Analog In	J20 - Bottom- Left J20 - Top - Right	J25 - TIP - Left J25 - RING - Right	J24 2-3
Microphone In	NA	J21 - TIP	J24 2-3

6. When using a microphone input, Potentiometer RX can be adjusted to increase or decrease the gain of the microphone amplifier.
7. Connect a destination to the output channels as shown in [Table 2.4](#).

Table 2.4 Output Channel Connectors

Channel	RCA	PhonoJack
Left	J10-CH3-Bottom	J18-Tip
Right	J10-CH3-Top	J18-Ring
Left Surround	J10-CH2-Bottom	J15-Tip
Right Surround	J10-CH2-Top	J15-Ring
Center	J10-CH1-Bottom	J12-Tip
Base	J10-CH1-Top	J12-Ring

www.DataSheet4U.com

8. Note that all output channels are line-level outputs and require an amplifier or powered speakers.
9. Turn the EB402/EB403 evaluation board power on.
10. Turn on the external power supply if one is being used.

A software driver for the CODEC-5.1 daughtercard is provided in the EB402 and EB403 Board Support Packages. These BSPs are included on the ZSP Development Kit (ZDK) CDROM supplied with the EB402 and EB403. For details of the CODEC-5.1 driver, please refer to the EB402 Board Support Package Technical Manual or EB403 Board Support Package Technical Manual.

Chapter 3

Operation

This chapter describes the CODEC-5.1 interfaces to the EB402/EB403 cards and the operation of its circuitry. It contains the following sections:

- [Section 3.1, "Interface to LSI402ZX/LSI403LP," page 3-1,](#)
- [Section 3.2, "Circuit Description," page 3-2](#)

www.DataSheet4U.com

3.1 Interface to LSI402ZX/LSI403LP

The AK4586 has two interfaces: a control interface and a data interface. The control interface is used to set the operating mode of the Codec chip and to read status information back. The data interface is used to read data, either digital audio or digitized analog inputs, and to write the 6 output channels.

Four GPIOs on the LSI402ZX/LSI403LP are used for the control interface. These signals comprise a clock, chip select, data in, and data out. All data is read and written from/to the control interface by manipulating individual bits in the PIO register.

Serial port 0 is used for the data interface to the codec. The AK4586 codec can be configured for TDM mode. This puts all three output pairs on a single serial port output wire and the input data on a single input wire.

Serial port 1 is used to provide a clock input to the AK4586 when in non-digital audio mode. By setting the clock rate of the serial port, the sample rate of the codec can be controlled. The sample rate of the codec is equal to the SP1 Clock Rate divided by 256. For example, to achieve a 44.1 kHz sample rate, the serial port clock rate should be $44.1\text{K} \times 256$ or 11.2896 MHz. Setting the EB402 clock rate at 170 MHz and using a

clock divider of 15 would yield a sample rate of 170 MHz/12/256 or 44.27 kHz, an error of 0.4%.

3.2 Circuit Description

This section describes the schematic for the audio daughtercard. The schematics for the CODEC-5.1 card are shown at the end of this manual. [Figure A.1](#) shows the hierarchical connections between the various blocks.

[Figure A.2](#) illustrates the connections to the EB402/3. Both SPORT0 and SPORT1 are used to provide access to the GPIO lines required. GPIO lines on the LSI402ZX/LSI403LP chip are used to control the 4-wire interface on the Codec. This four-wire interface is used to configure the codec and read back status information. SPORT0 contains the serial TDM interface between the AK4586 Codec and the ZSP processor. The TX clock from SPORT1 is routed to the clock input of the AK4586. When no external digital source is present, the AK4586 will automatically switch to the clock input signal to generate its clock. This allows the codec rate to be set under program control. The codec produces 2 interrupts which are routed to the LSI402ZX/LSI403LP to pins INT2 and INT3. These interrupt lines are used to indicate operational status like the lock signal, non-PCM data stream, etc.

[Figure A.3](#) contains the connections to the AK4586 Codec. A separate +5V regulator is used to provide the +5V rail required for the AK4586. U11 generates a reset pulse at powerup for the AK4586.

[Figure A.4](#) shows the power supplies for the daughtercard. U2 is used to provide the +7V supply for the op-amps when using internal power. The analog power used by the amplifiers can either be produced on the CODEC-5.1 or through an external power supply. Jumpers J3, J4, and J5 are used to select either internally generated power or external power. J5, when installed, shuts down both U3 and U4. U3 generates a -9V rail from the +9V supplied from the EB402, and U4 generates -7V from the -9V supply. The use of external supplies helps to reduce noise in sensitive environments, while the internal supplies provide a level of convenience for development purposes. J9 provides the common connection between the analog and digital ground planes and must be always installed. The artwork includes a permanent connection across J9

on the top layer which can be cut for those applications requiring a separated ground system.

[Figure A.5](#) shows the Audio connections on and off the board. J10 contains the 6 output channels in an RCA block connector. J12, J15, and J18 provide the same output connections in 3.5mm line-output jacks. J12 provides Left and Right channels for either 6 channel output or for stereo output. J15 provides Left Surround and Right Surround for 6 channel outputs. J18 provides Center and Base for 6 channel outputs. J19 is an RCA connector for the SPDIF input source, typically a DVD player. J23 is a SPDIF output pass through connection. J20 provides an RCA-style input connection for left and right stereo channels, and J25 provides the input connection using a phonojack input. J21 is a microphone input for a mono electret microphone.

www.DataSheet4U.com

[Figure A.6](#) shows the amplifiers for each of the output DAC channels, the stereo line-inputs, and the microphone input. [Figure A.7](#) shows one of the output DAC amplifiers. This amplifier will produce a +/- 3V signal suitable for driving line-level outputs.

[Figure A.13](#) shows a line-input amplifier. This amplifier takes a line-level input signal and produces a valid analog input signal for the codec.

[Figure A.14](#) shows the microphone amplifier circuit. This circuit provides power and amplification for an electret microphone. R38 is available on the board to adjust the gain of the amplifier.

Appendix A

Schematics

www.DataSheet4U.com

Figure A.1

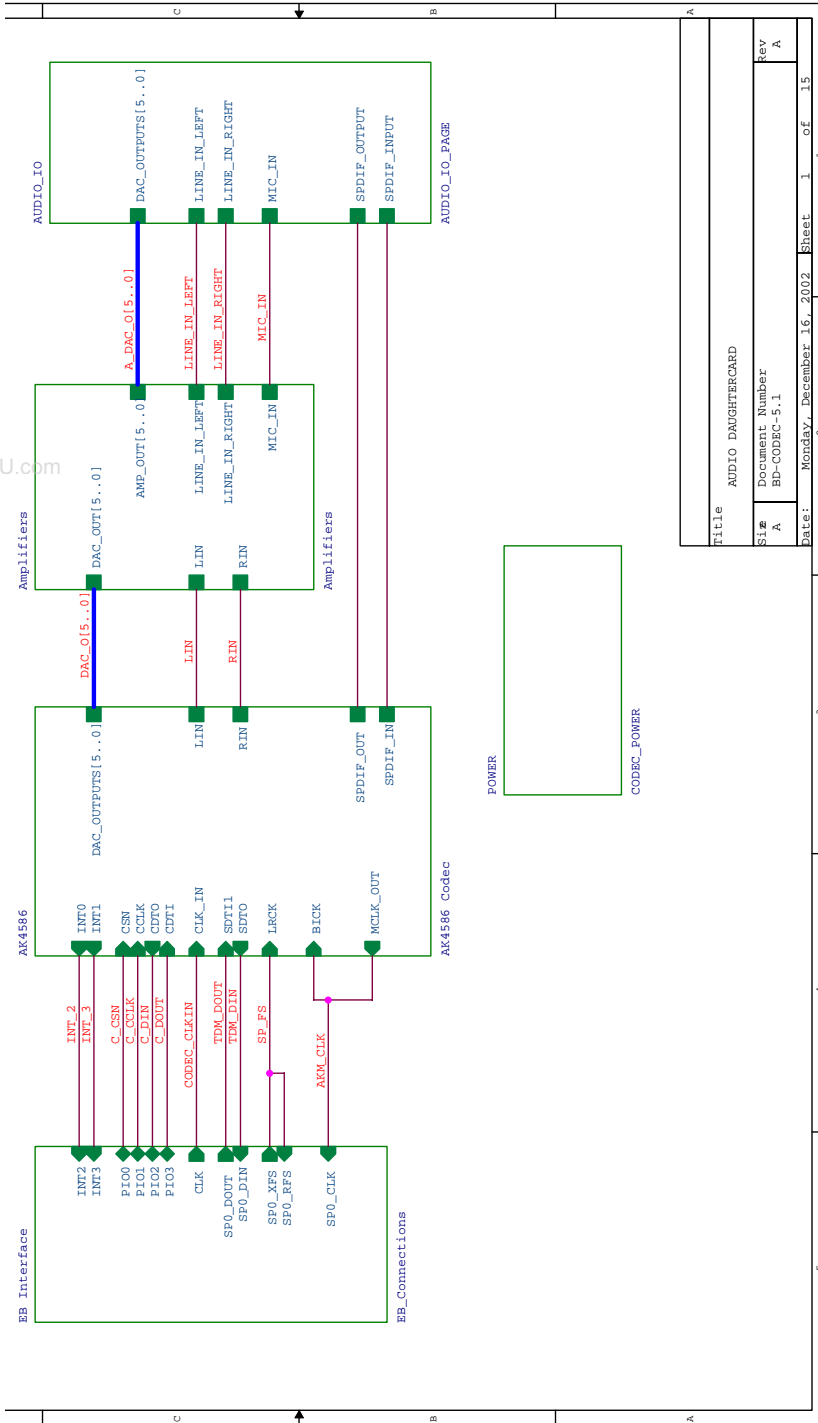
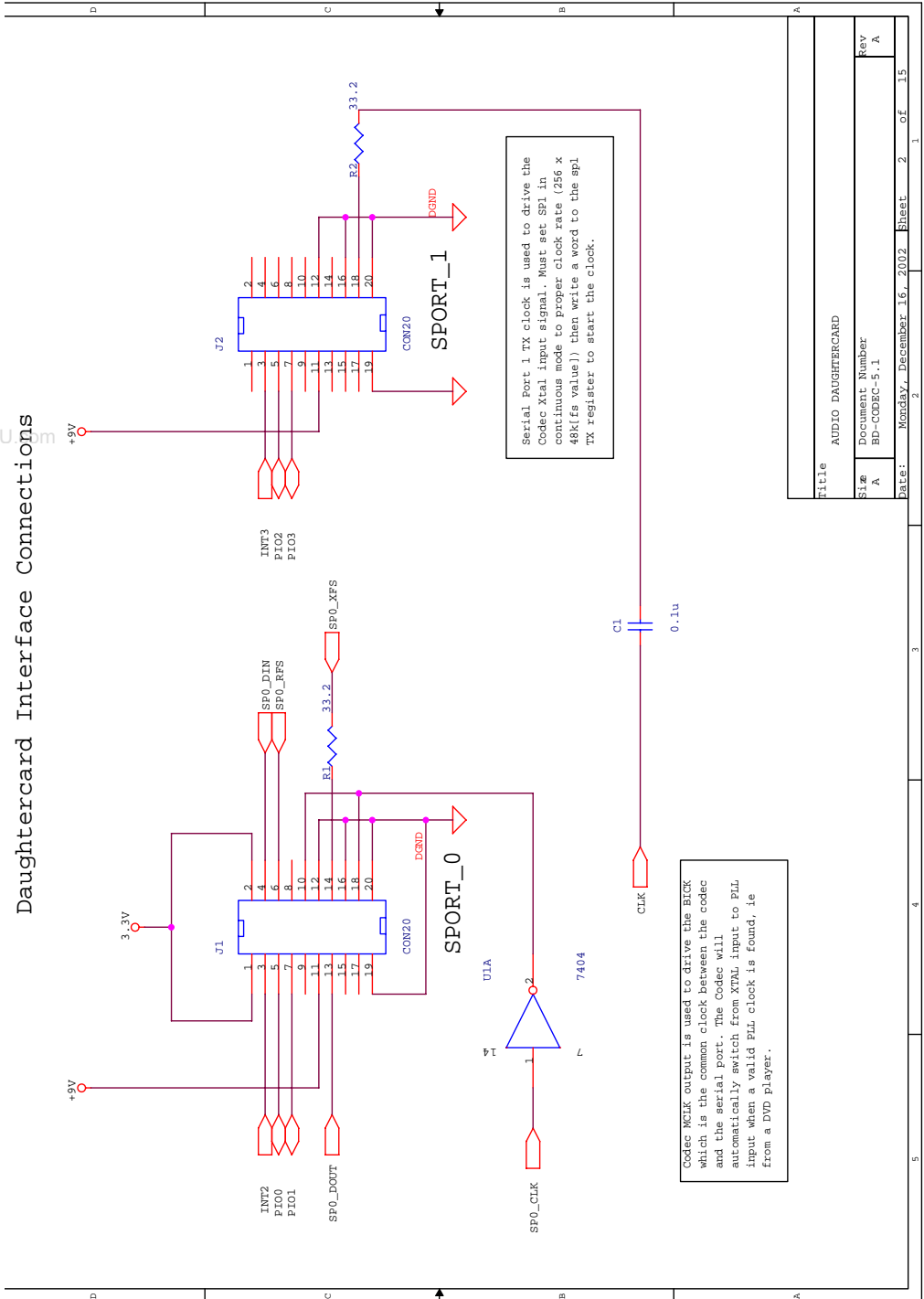

Figure A.2

Daughtercard Interface Connections



Title		AUDIO DAUGHTERCARD	
Size	Document Number	BD-CODEC-5.1	
Rev	Rev	A	
Date:	Monday, December 16, 2002	Sheet	2 of 15

Figure A.3

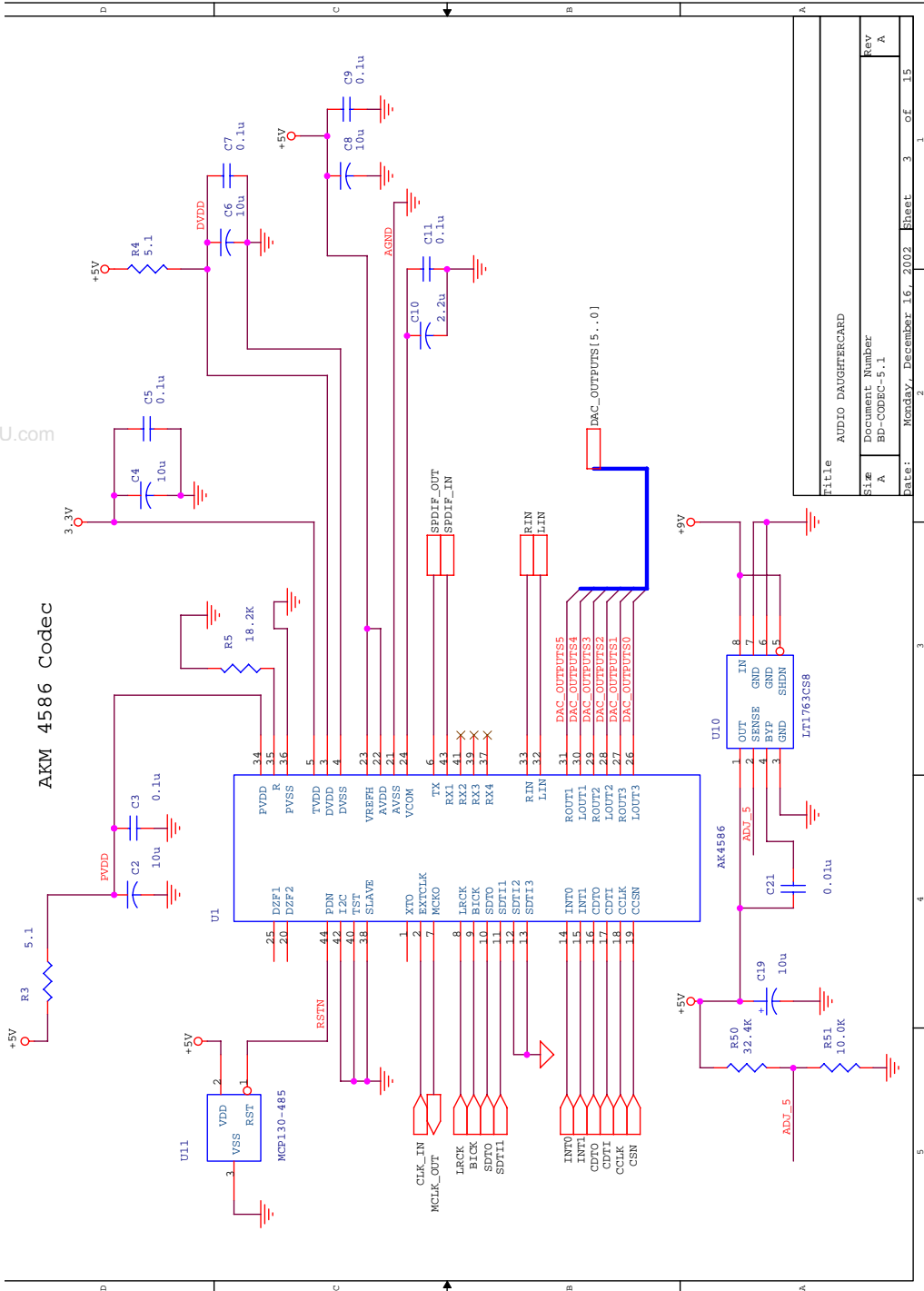

Title		AUDIO DAUGHTERCARD	
Size	Document Number	BD-CDECB-5.1	
A	Rev	A	
Date:	Monday, December 16, 2002	Sheet	3 of 15

Figure A.4

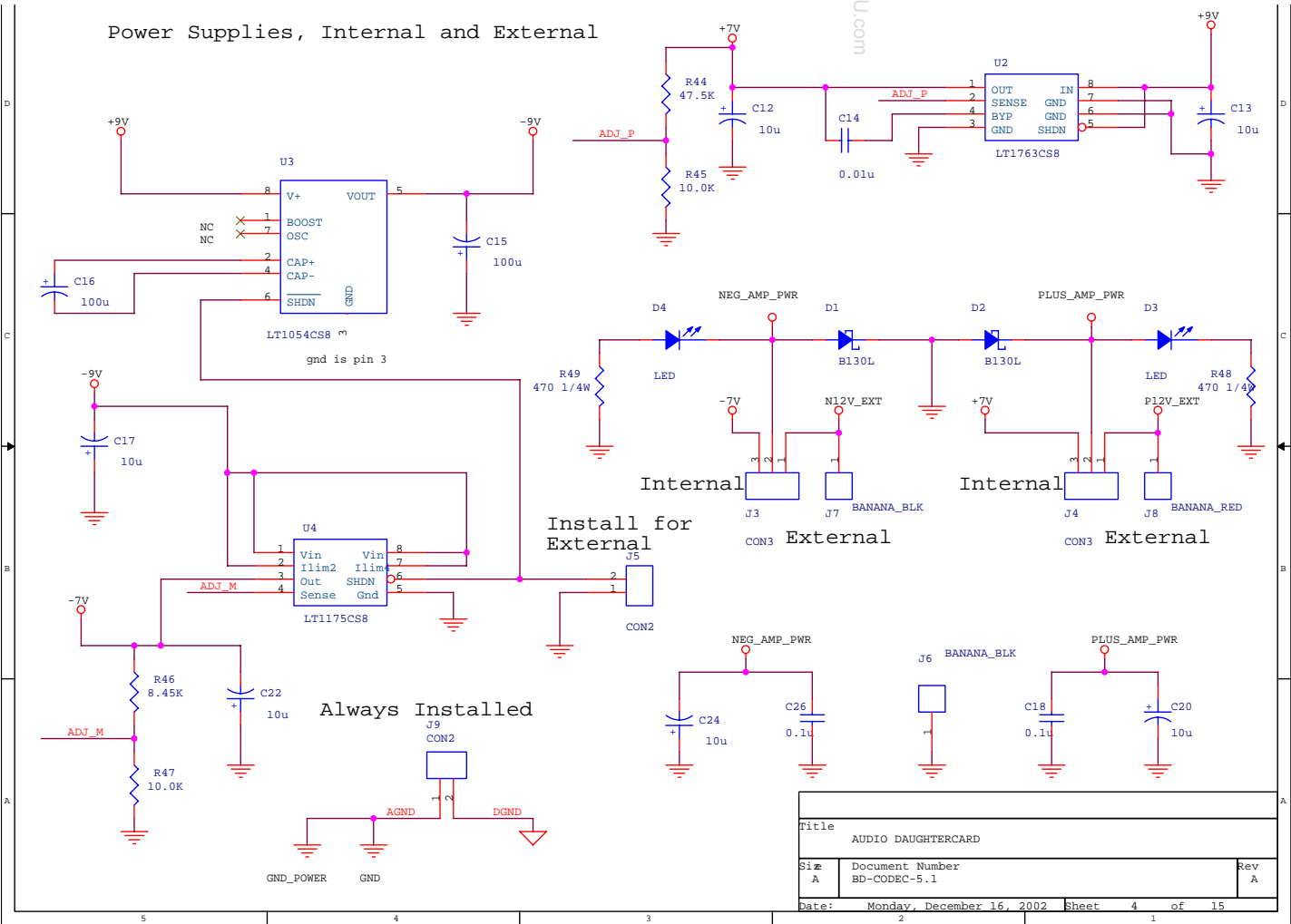

www.DataSheet4U.com

January 2003

Rev A Copyright © 2002-2003 by LSI Logic Corporation. All rights reserved.

www.DataSheet4U.com

Figure A.5

Connectors

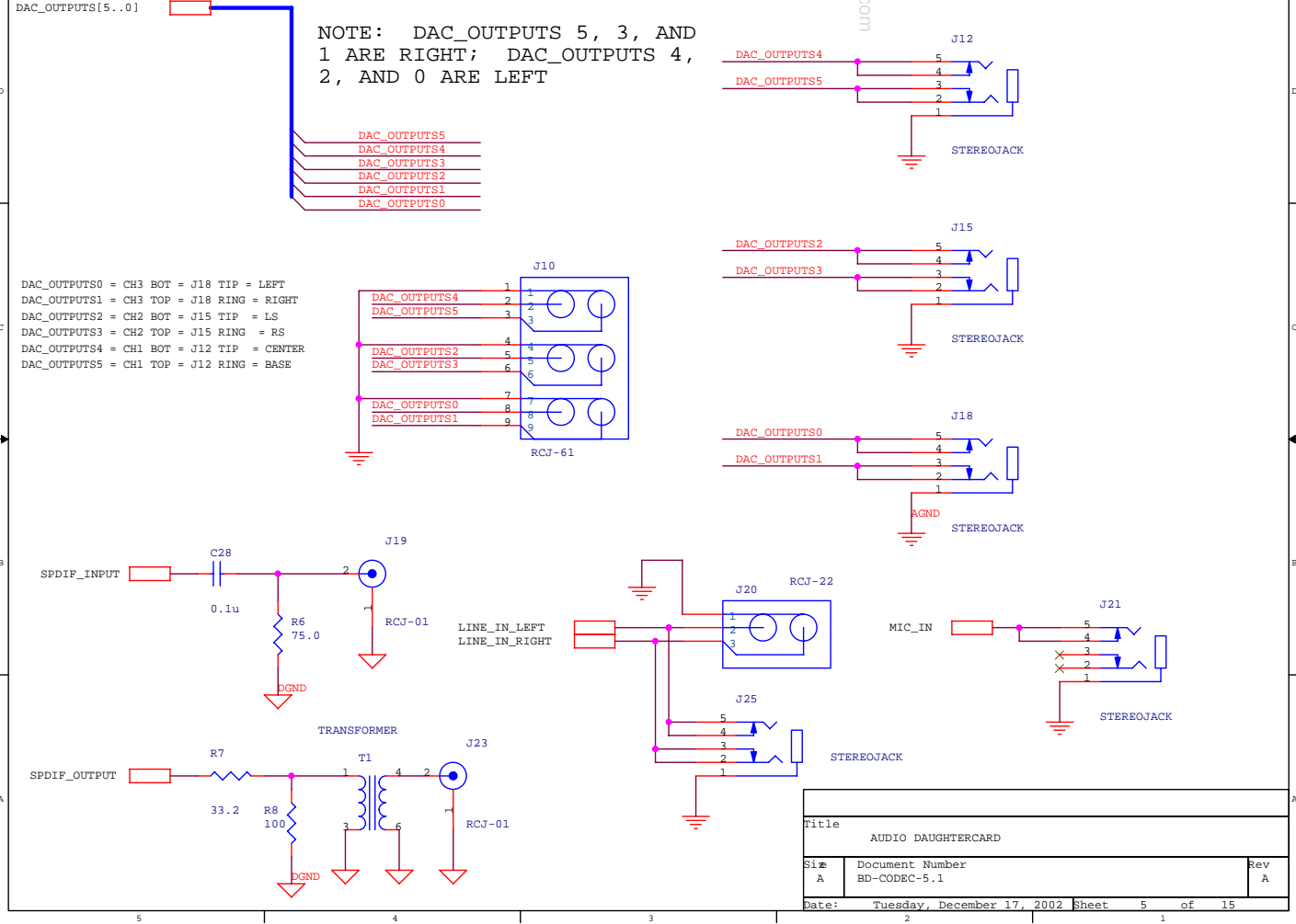

Title		
AUDIO DAUGHTERCARD		
Size	Document Number	Rev
A	BD-CODEC-5.1	A
Date:	Tuesday, December 17, 2002	Sheet 5 of 15

Figure A.6

Amplifiers for Input, Output, and Microphone

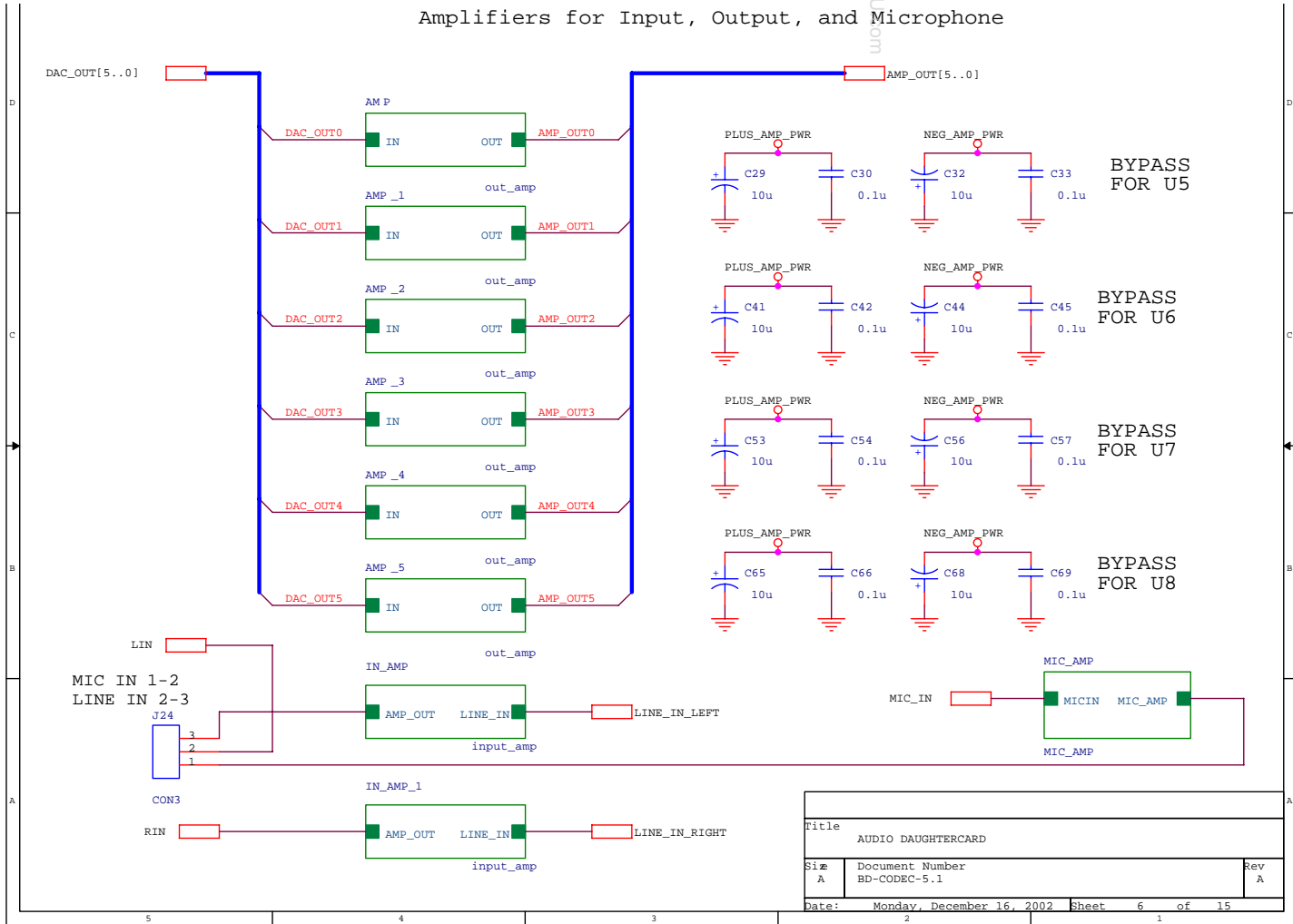

Title		
AUDIO DAUGHTERCARD		
Size	Document Number	Rev
A	BD-CODEC-5.1	A
Date:	Monday, December 16, 2002	Sheet 6 of 15
	2	1

Figure A.7

Output Amplifier for each DAC channel

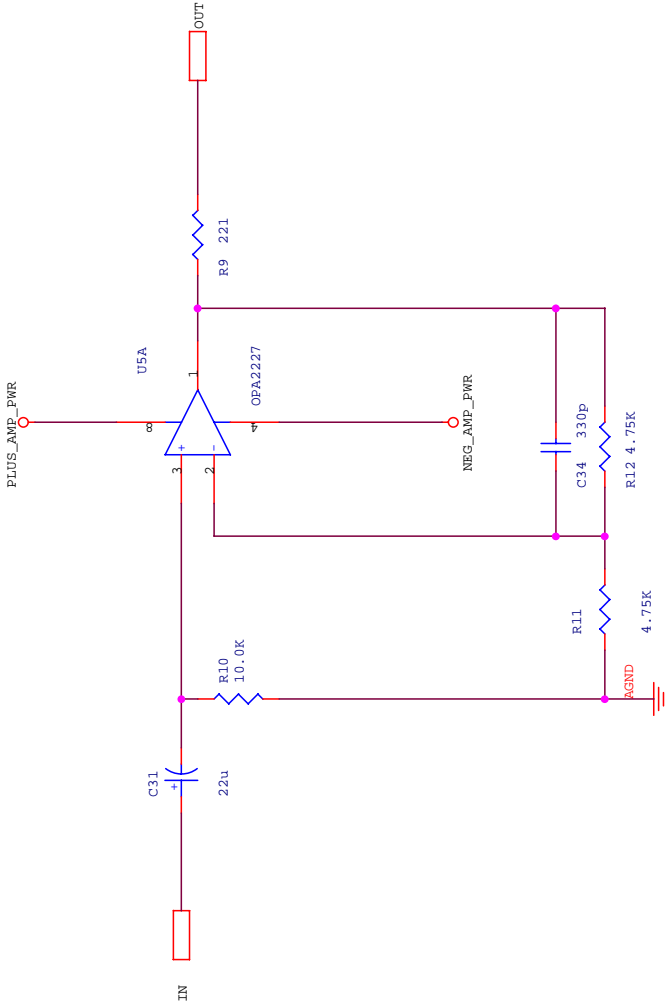

www.DataSheet4U.com

Title		AUDIO DAUGHTERCARD	
Size	Document Number	Rev	
A	BD-CODEC-5.1	A	
Date:	Monday, December 16, 2002	Sheet	7 of 15

Figure A.8

Output Amplifier for each DAC channel

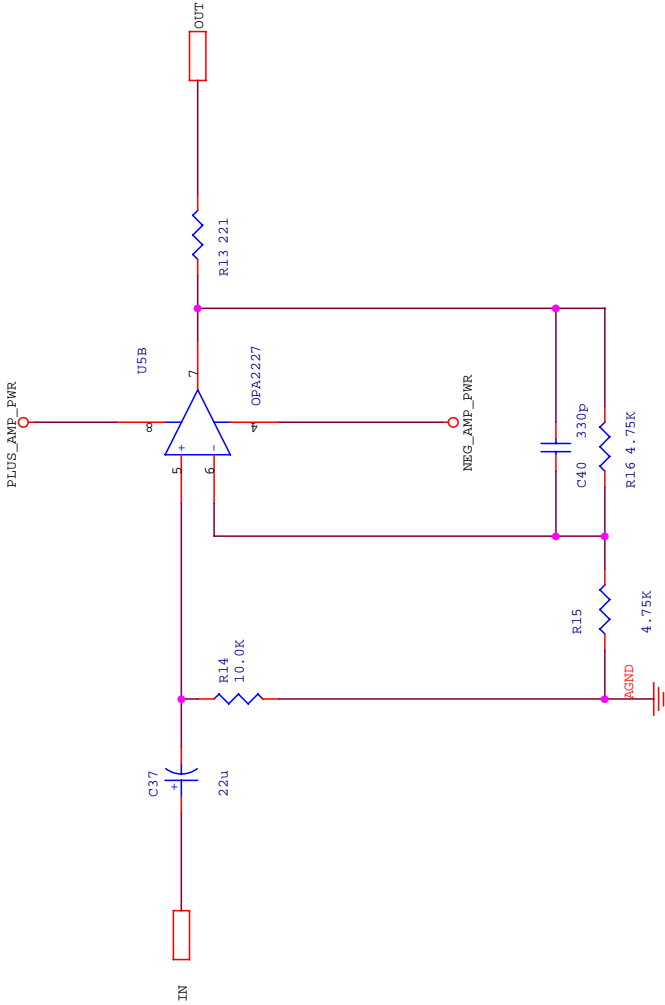

Title		PRO AUDIO DAUGHTERCARD	
Size	Document Number		
A	BD-CODEC-5.1	Rev	A
Date:	Monday, December 16, 2002	Sheet	8 of 15

5 4 3 2 1

Figure A.9

Output Amplifier for each DAC channel

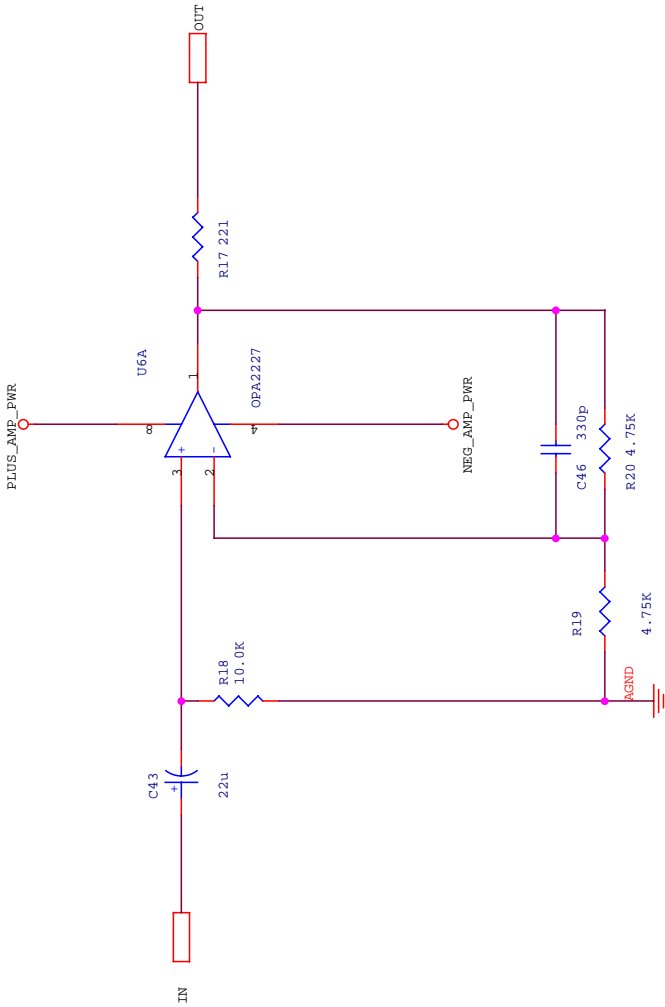

Title		PRO AUDIO DAUGHTERCARD
Size	Document Number	BD-CODEC-5.1
A	Rev	A
Date:	Monday, December 16, 2002	Sheet 9 of 15

5 4 3 2 1

Figure A.10

Output Amplifier for each DAC channel

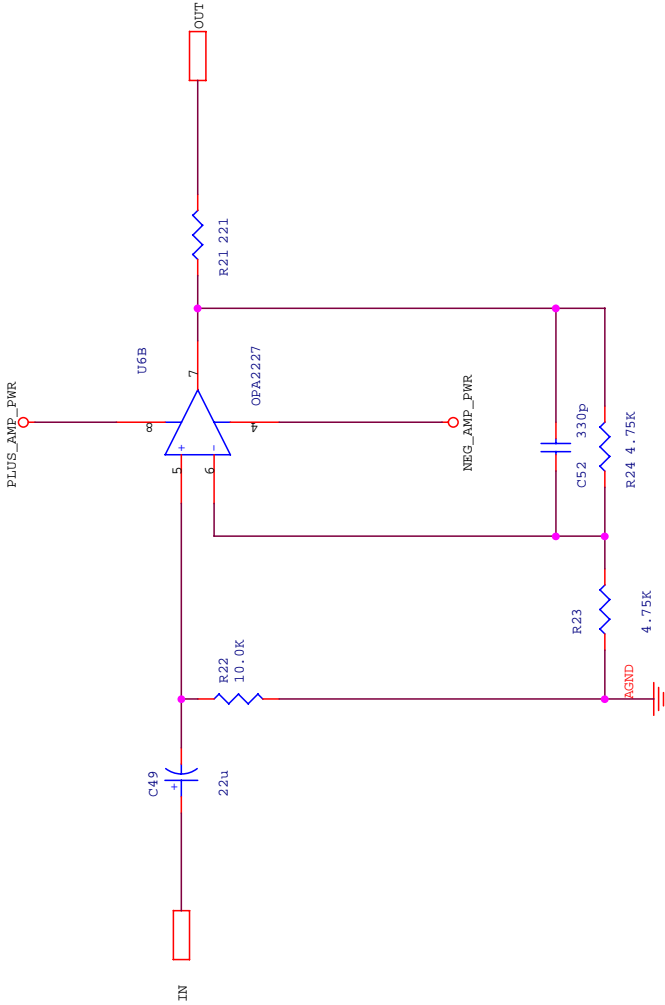

Title		PRO AUDIO DAUGHTERCARD
Size	Document Number	BD-CODEC-5.1
A	Rev	A
Date:	Monday, December 16, 2002	Sheet 10 of 15

Figure A.11

Output Amplifier for each DAC channel

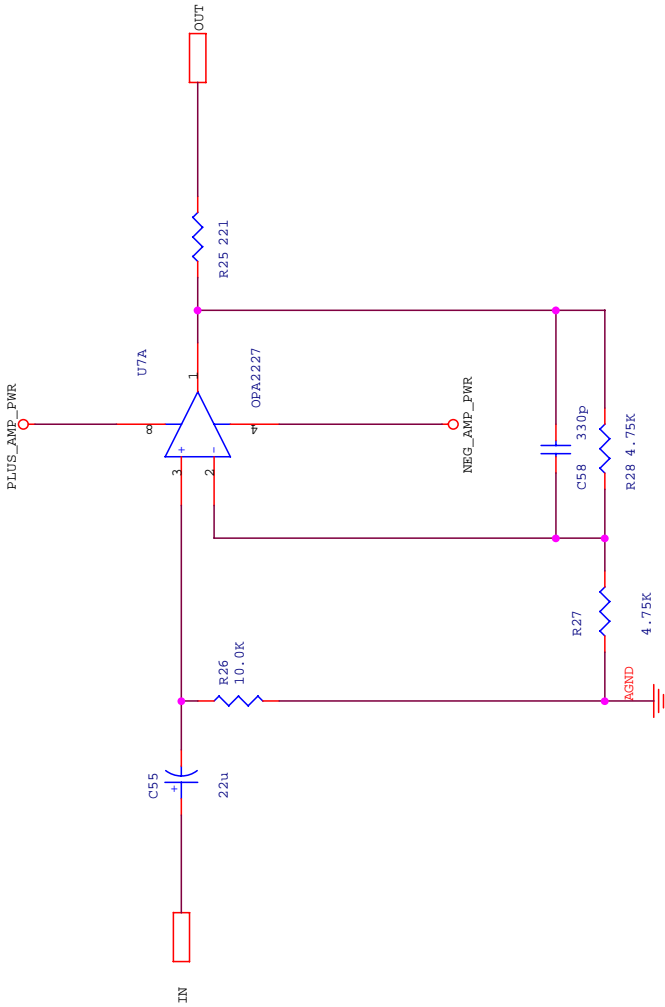

www.DataSheet4U.com

Title		PRO AUDIO DAUGHTERCARD
Size	Document Number	BD-CODEC-5.1
A	Rev	A
Date:	Monday, December 16, 2002	Sheet 11 of 15

Figure A.12

Output Amplifier for each DAC channel

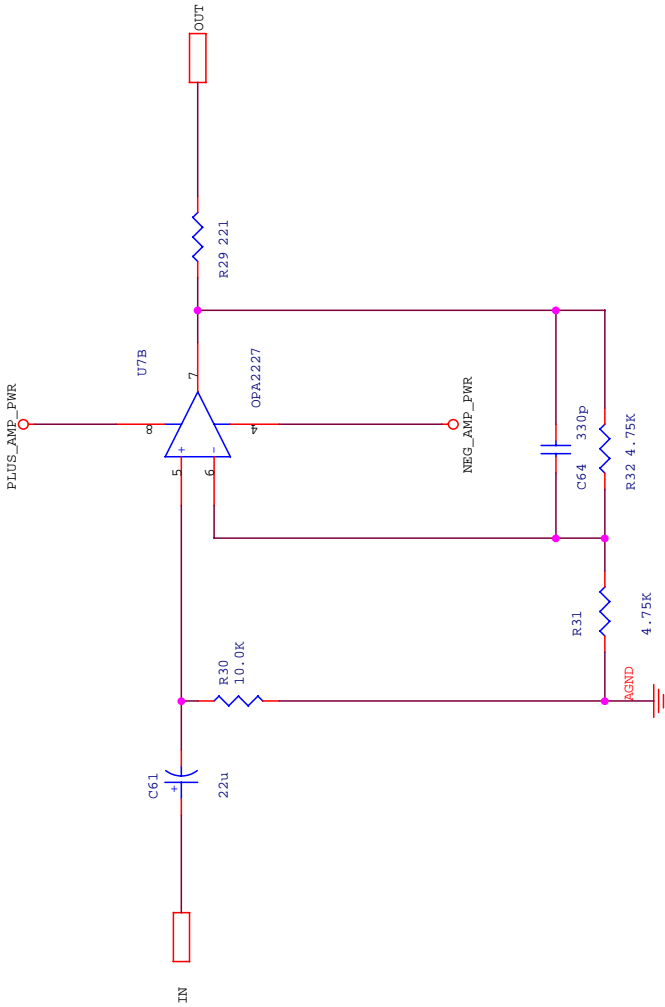

www.DataSheet4U.com

Title		PRO AUDIO DAUGHTERCARD
Size	Document Number	
A	BD-CODEC-5.1	
Date:		Monday, December 16, 2002
Sheet		12 of 15

1 2 3 4 5

Figure A.13

Line Input Amplifier

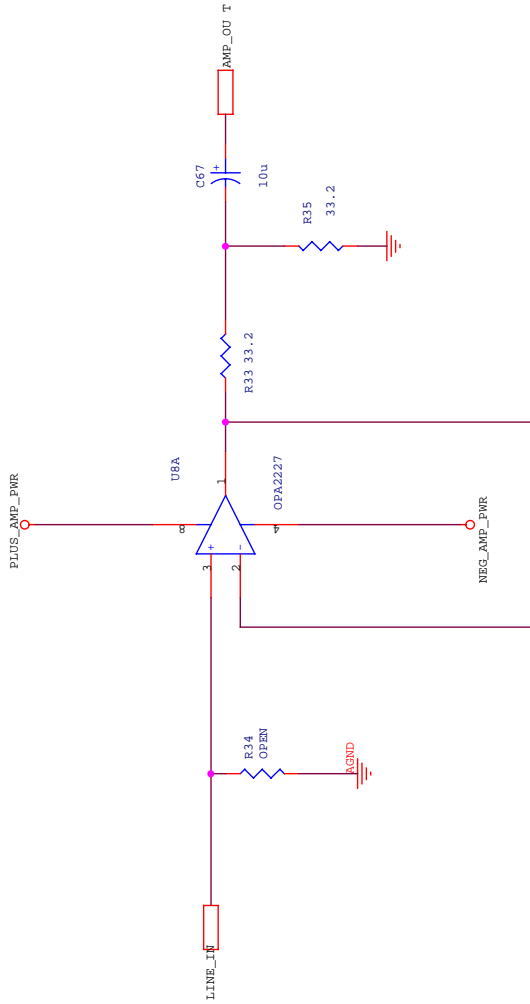

www.DataSheet4U.com

Title		AUDIO DAUGHTERCARD	
SI #	Document Number	Rev	Rev
A	BP-C08EC-5.1		A
Date:	Monday, December 16, 2002	Sheet	13 of 15

1 2 3 4 5

Figure A.14

Microphone Input Amplifier

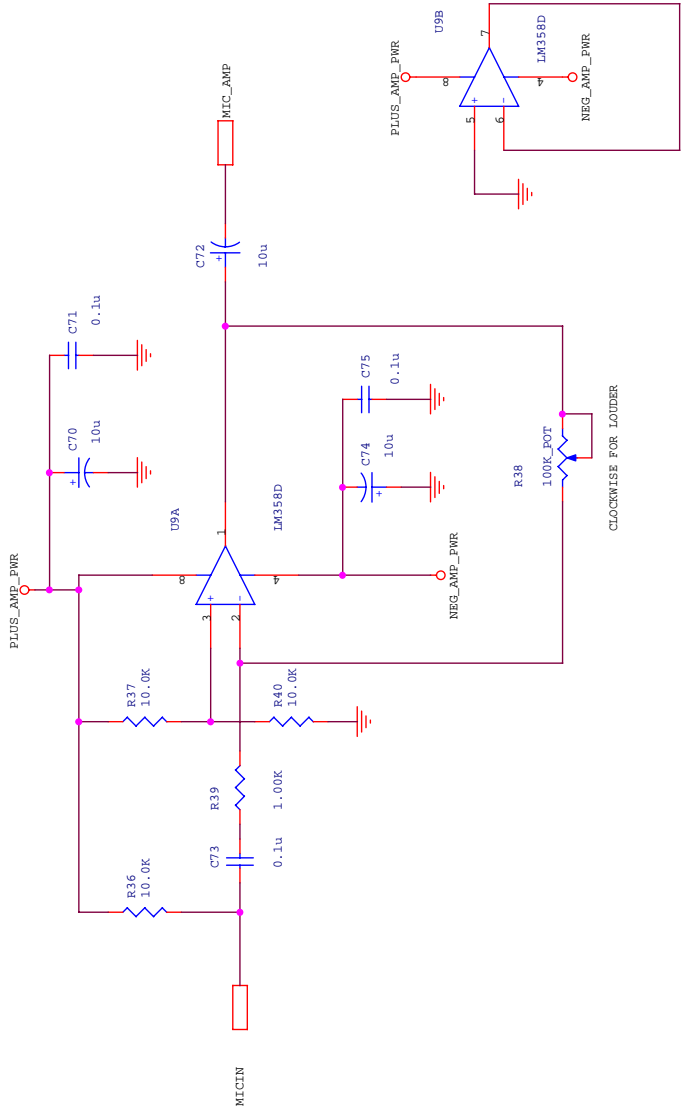

File	AUDIO DAUGHTERCARD
Size	Document Number A BD-CODEC-5.1
Rev	A
Date:	Monday, December 16, 2002
Sheet	14 of 15

Figure A.15

Line Input Amplifier

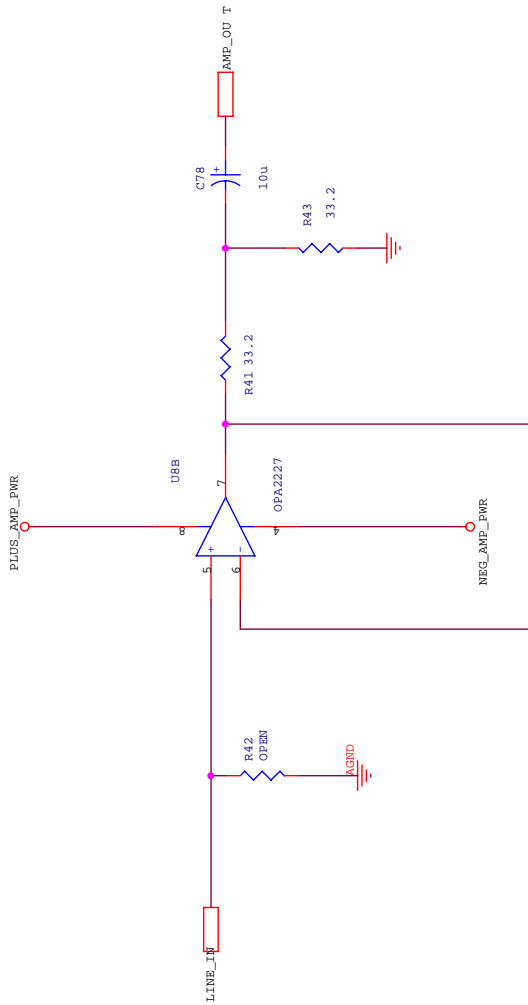

Title PRO AUDIO DAUGHTERCARD

SI # Document Number BP-C08EC-5.1

Rev A

Date: Monday, December 16, 2002 Sheet 15 of 15

1

2

3

4

5