

## 2A 380KHZ 20V PWM Buck DC/DC Converter

### General Description

The EC9413 is a 380 KHz fixed frequency monolithic step down switch mode regulator with a built in internal Power MOSFET. It achieves 2A continuous output current over a wide input supply range with excellent load and line regulation.

The device includes a voltage reference, oscillation circuit, error amplifier, internal PMOS and etc.

The PWM control circuit is able to adjust the duty ratio linearly from 0 to 100%. An enable function, an over current protection function and a short circuit protection function are built inside. An internal compensation block is built in to minimize external component count.

The EC9413 serves as ideal power supply units for portable devices.

### Features

- 2A Constant Output Current
- 140mΩ R<sub>DS(ON)</sub> Internal Power PMOSFET Switch
- Up to 95% Efficiency
- Fixed 380KHz Frequency
- Wide 3.6V to 20V Input Voltage Range
- Output Adjustable from 1.20V to 18V
- Built in Frequency Compensation
- Built in Thermal Shutdown Function
- Built in Current Limit Function
- SOP8 Package is Available
- The minimum dropout up to 0.3V

### Applications

- Portable DVD
- LCD Monitor / TV
- Battery Charger
- ADSL Modem
- Telecom / Networking Equipment

### Block Diagram

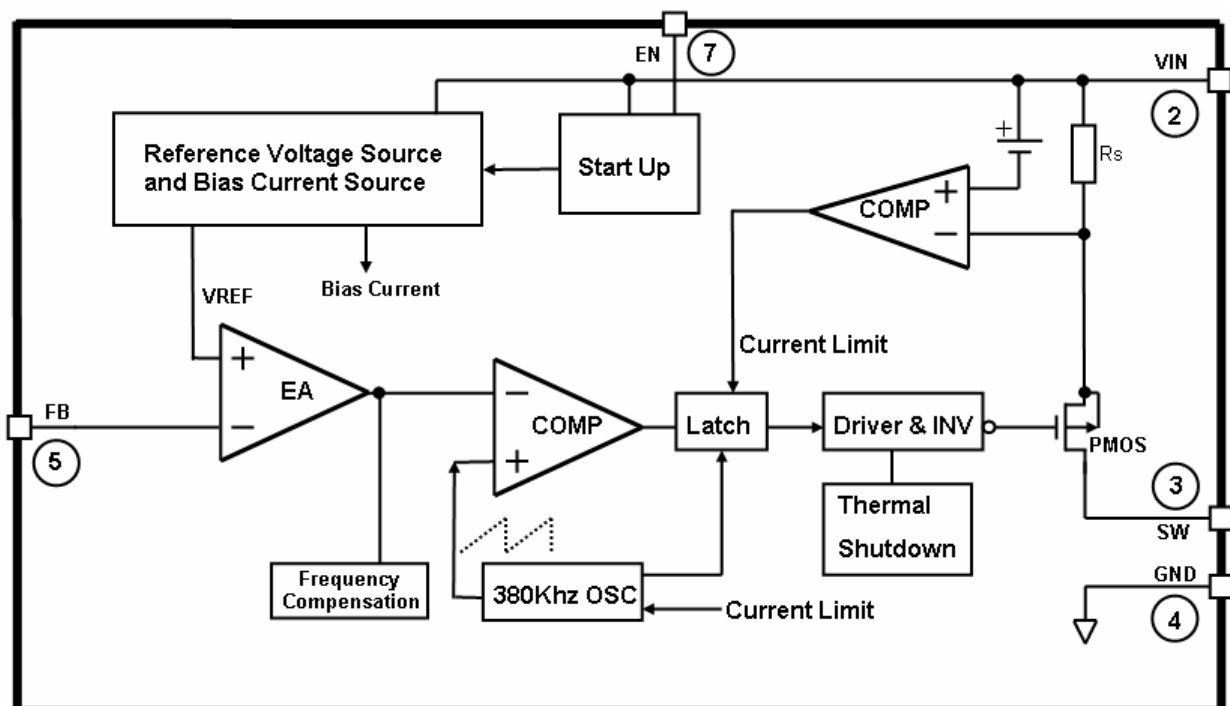

## 2A 380KHZ 20V PWM Buck DC/DC Converter

### Pin Configuration

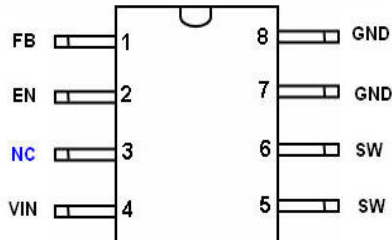

### Pin Description

Pin No.	Symbol	Description
1	FB	Feedback Pin. Through an external resistor divider network, FB senses the output voltage and regulates it. The feedback threshold voltage is 1.20V.
2	EN	Enable Pin. Drive EN pin high to turn on the device, drive it low to turn it off.
3	NC	Not Connect
4	Vin	Supply Voltage Input Pin. EC9413 operates from a 3.6V to 20V DC voltage. Bypass Vin to GND with a suitably large capacitor to eliminate noise on the input.
5,6	SW	Power Switch Output Pin. SW is the switch node that supplies power to the output.
7,8	GND	Ground Pin. Care must be taken in layout. This pin should be placed outside of the Schottky Diode to output capacitor ground path to prevent switching current spikes from inducing voltage noise into EC9413.

### Ordering/ Marking Information

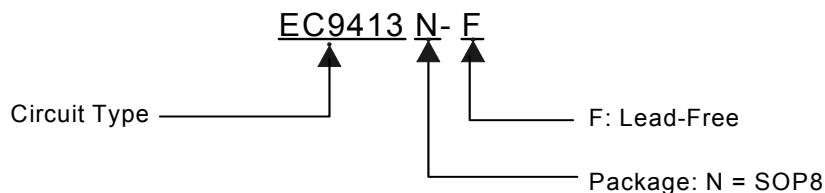

Package type	Part Number	Marking	Marking Information
SOP8	EC9413N-F	EC9413-F YYWW XXXXXXXXXX	F is Lead free package. YY is the year of production. 06 means the product is manufactured in year of 2006. WW is the week of production. 25 means the product is manufactured in the 25 <sup>th</sup> week. XXXXXXXXXX is Lot number.

**2A 380KHZ 20V PWM Buck DC/DC Converter****Absolute maximum ratings**

Parameter	Symbol	Value	Unit
Input Voltage	$V_{IN}$	-0.3 to 20	V
Feedback Pin Voltage	$V_{FB}$	-0.3 to $V_{in}$	V
Enable Pin Voltage	$V_{EN}$	-0.3 to 12	V
Switch Pin Voltage	$V_{SW}$	-0.3 to $V_{in}$	V
Power Dissipation	$P_D$	Internally limited	mW
Operating Junction Temperature	$T_J$	150	°C
Storage Temperature	$T_{STG}$	-65 to 150	°C
Lead Temperature (Soldering, 10 sec)	$T_{LEAD}$	260	°C
ESD (HBM)	$V_{ESD}$	2000	V

Note1: Stresses greater than those listed under Maximum Ratings may cause permanent damage to the device. This is a stress rating only and functional operation of the device at these or any other conditions above those indicated in the operation is not implied. Exposure to absolute maximum rating conditions for extended periods may affect reliability.

**Recommended Operating Conditions**

Parameter	Symbol	Min.	Max.	Unit
Input Voltage	$V_{IN}$	3.6	20	V
Operating Junction temperature	$T_J$	-40	125	°C
Operating Ambient Temperature	$T_A$	-40	85	°C

**2A 380KHZ 20V PWM Buck DC/DC Converter****Electrical Characteristics**

VCC = 12V, TA = 25°C unless otherwise specified.

Parameters	Symbol	Test Condition	Min.	Typ.	Max.	Unit
Input voltage	V <sub>IN</sub>	-	3.6	-	20	V
Shutdown Supply Current	I <sub>STBY</sub>	V <sub>EN</sub> =0V	-	30	90	uA
Supply Current	I <sub>CC</sub>	V <sub>EN</sub> =2V, V <sub>FB</sub> =1.3V	-	3.6	4	mA
Feedback Voltage	V <sub>FB</sub>	V <sub>IN</sub> = 3.6V to 23V	1.164	1.20	1.236	V
Feedback Bias Current	I <sub>FB</sub>	V <sub>FB</sub> =1.3V	-	0.1	0.5	uA
Switch Current Limit	I <sub>LIM</sub>	-	-	3	4	A
Oscillator Frequency	F <sub>OSC</sub>	-	320	380	440	KHz
Frequency of Current Limit or Short Circuit Protection	F <sub>OSC1</sub>	V <sub>FB</sub> =0V	-	42	-	KHz
EN Pin Threshold	V <sub>EN</sub>	-	0.7	1.2	1.7	V
EN Pin Input Leakage Current	I <sub>H</sub>	V <sub>EN</sub> =2.5V	-	-0.1	-1	uA
	I <sub>L</sub>	V <sub>EN</sub> =0.5V	-	-3	-10	uA
Internal PMOS R <sub>DS(on)</sub>	R <sub>DS(on)</sub>	V <sub>IN</sub> =12V, V <sub>FB</sub> =0V V <sub>EN</sub> =12V, I <sub>out</sub> =2A	-	140	-	mΩ
Max. Duty Cycle	D <sub>MAX</sub>	V <sub>FB</sub> =0V, I <sub>SW</sub> =0.1A	-	100	-	%
Efficiency	η	V <sub>IN</sub> =12V, V <sub>out</sub> =5V I <sub>out</sub> =2A	-	92	-	%
Thermal Shutdown	T <sub>OTSD</sub>	-	-	165	-	°C

Typical Performance Characteristics

Switching Frequency vs. Temperature

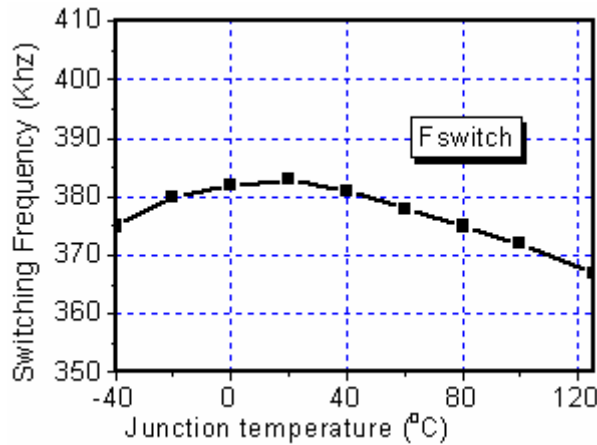

Vfb vs. Temperature

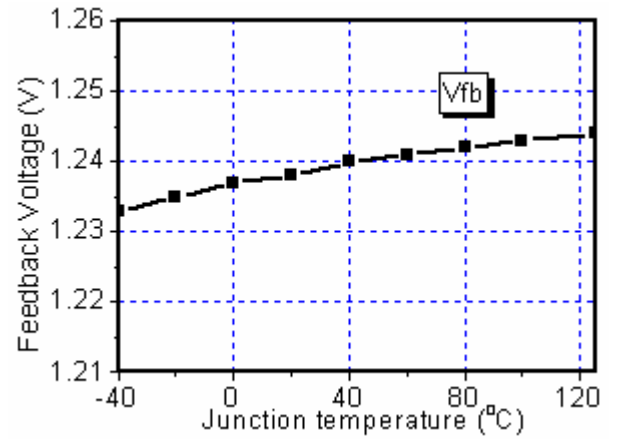

Icc vs. Temperature

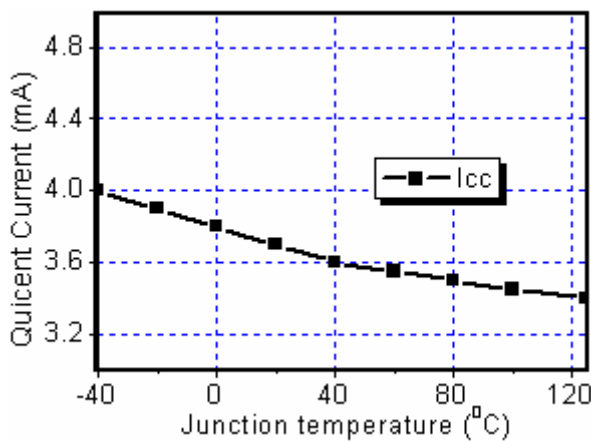

Efficiency vs. Load (Vin=10V)

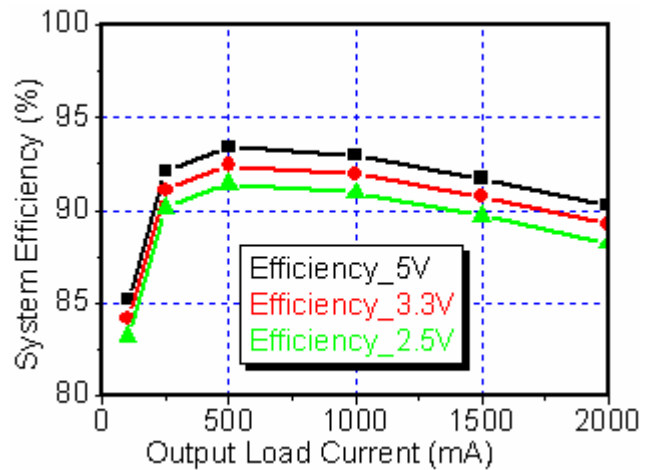

## 2A 380KHZ 20V PWM Buck DC/DC Converter

### Typical Application Circuit

Typical Application Circuit @ 5V/2A

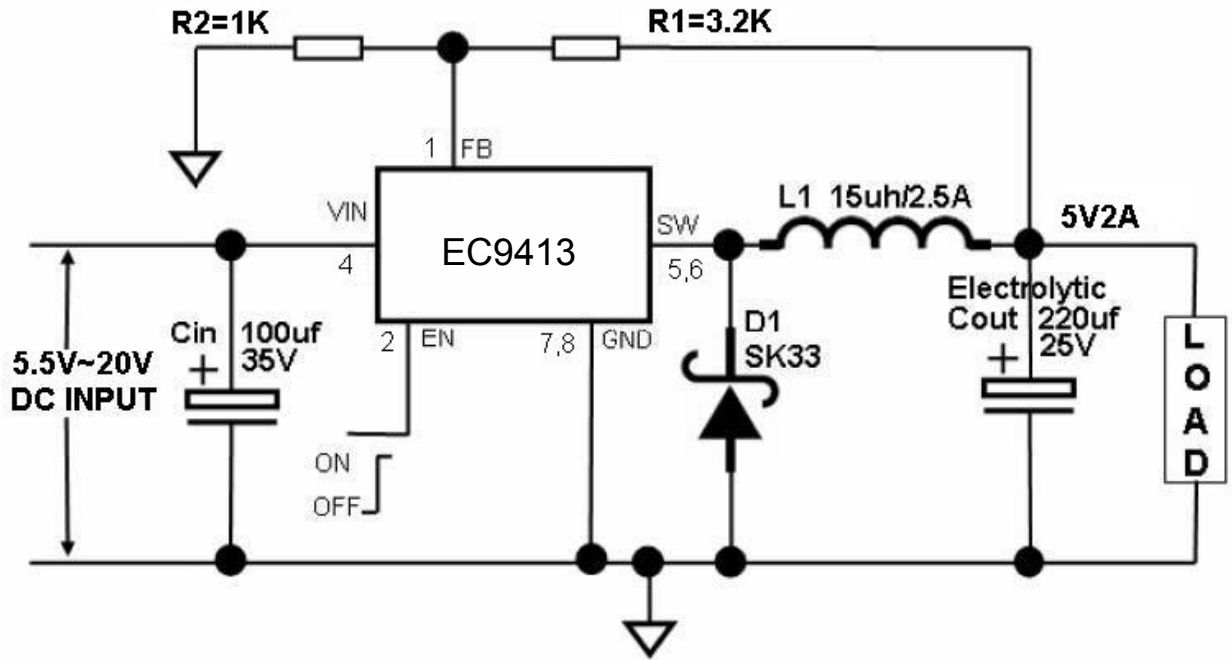

Typical Application Circuit @ 3.3V/2A

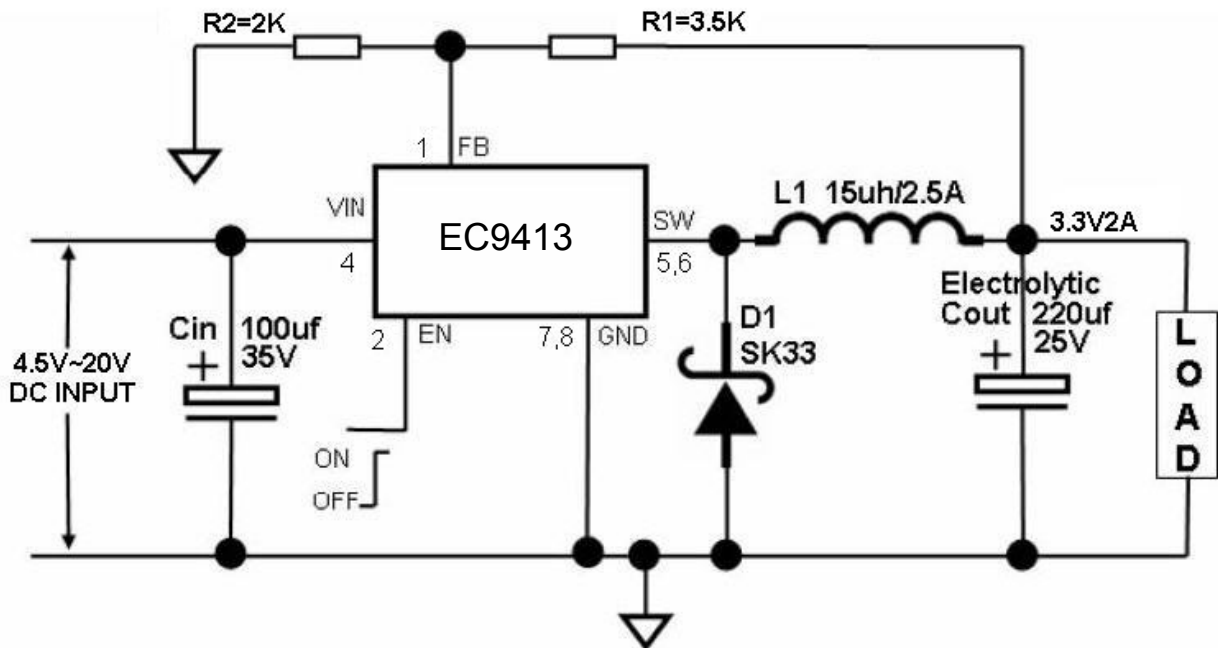

## 2A 380KHZ 20V PWM Buck DC/DC Converter

### Typical Application Circuit (Continued)

Typical Application Circuit (with ceramic output capacitor) @ 5V/2A

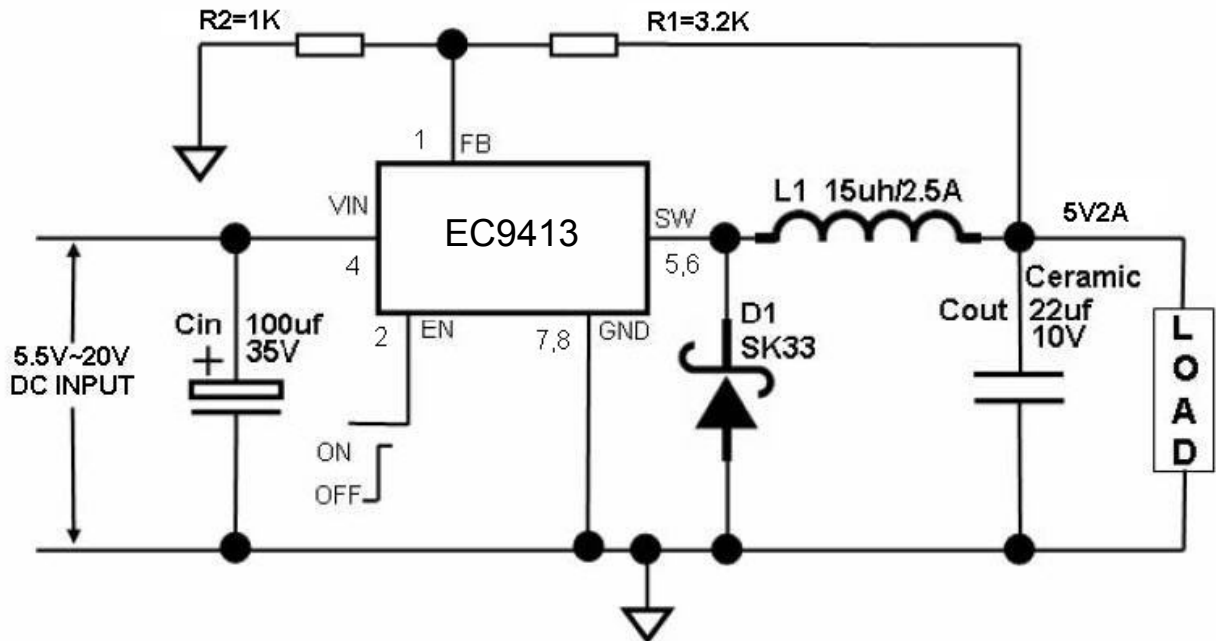

Typical Application Circuit (with ceramic output capacitor) @ 3.3V/2A

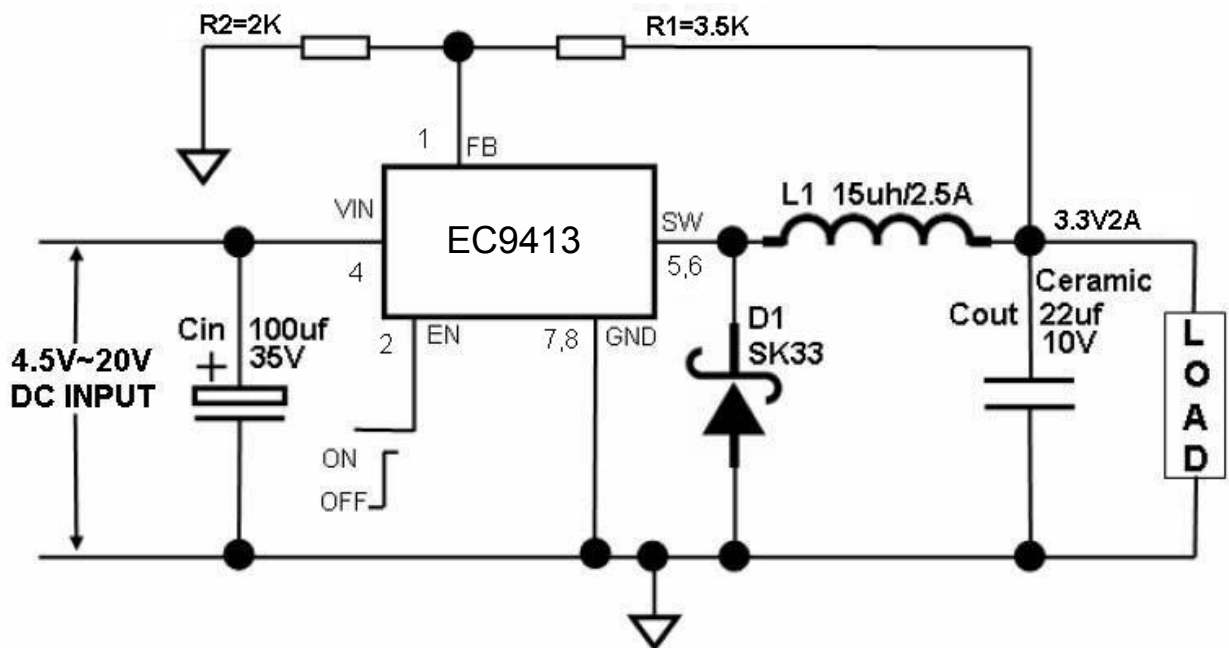

## 2A 380KHZ 20V PWM Buck DC/DC Converter

### Schottky Rectifier Selection Guide

EC9413 lists some rectifier manufacturers.

Vin (Max)	2A Load Current	
	Part Number	Vendor
20V	B220	Diodes, Inc.
	SK23	Pan Jit International
	SR22	Pan Jit International

### Output Voltage vs. R1, R2 Resistor Selection Guide (Vout = (1+R1/R2)\*1.20V)

EC9413 Vout vs. R1, R2 Select Table

Vout	R1	R2
1.8V	2K	1K
2.5V	2K	2.2K
3.3V	3.5K	2K
5V	3.2K	1K
9V	13K	2K
12V	18K	2K





## 2A 380KHZ 20V PWM Buck DC/DC Converter

---

### Function Description

#### VIN

This is the positive input supply for the IC switching regulator. A suitable input bypass capacitor must be present at this pin to minimize voltage transients and to supply the switching currents needed by the regulator

#### Gnd

Circuit ground.

#### SW

Internal switch. The voltage at this pin switches between  $(V_{IN} - V_{GS})$  and approximately  $-0.5V$ , with a duty cycle of approximately  $V_{OUT} / V_{IN}$ . To minimize coupling to sensitive circuitry, the PC board copper area connected to this pin should be kept a minimum.

#### FB

Senses the regulated output voltage to complete the feedback loop.

#### EN

Allows the switching regulator circuit to be shutdown using logic level signals thus dropping the total input supply current to approximately 30uA. Pulling this pin below a threshold voltage of approximately 1.3 V turns the regulator down, and pulling this pin above 1.3V (up to a maximum of 12V) shuts the regulator on. If this shutdown feature is not needed the EN pin can be wired to the VIN pin or it can be left open, in either case the regulator will be in the ON condition

### Thermal Considerations

The SOP8 package needs a heat sink under most conditions. The size of the heat sink depends on the input voltage, the output voltage, the load current and the ambient temperature. The EC9413 junction temperature rises above ambient temperature for a 2A load and different input and output voltages. The data for these curves was taken with the EC9413 (SOP8 package) operating as a buck-switching regulator in an ambient temperature of 25 °C (still air). These temperature rise numbers are all approximate and there are many factors that can affect these temperatures. Higher ambient temperatures require more heat sinking.

For the best thermal performance, wide copper traces and generous amounts of printed circuit board copper should be used in the board layout. (Once exception to this is the output (switch) pin, which should not have large areas of copper.) Large areas of copper provide the best transfer of heat (lower thermal resistance) to the surrounding air, and moving air lowers the thermal resistance even further.

Package thermal resistance and junction temperature rise numbers are all approximate, and there are many factors that will affect these numbers. Some of these factors include board size, shape, thickness, position, location, and even board temperature. Other factors are, trace width, total printed circuit copper area, copper thickness, single or double-sided, multi-layer board and the amount of solder on the board.

The effectiveness of the PC board to dissipate heat also depends on the size, quantity and spacing of other components on the board, as well as whether the surrounding air is still or moving. Furthermore, some of these components such as the catch diode will add heat to the PC board and the heat can vary as the input voltage changes. For the inductor, depending on the physical size, type of core material and the DC resistance, it could either act as a heat sink taking heat away from the board, or it could add heat to the board.

## 2A 380KHZ 20V PWM Buck DC/DC Converter

### OUTLINE DRAWING FOR SOP8

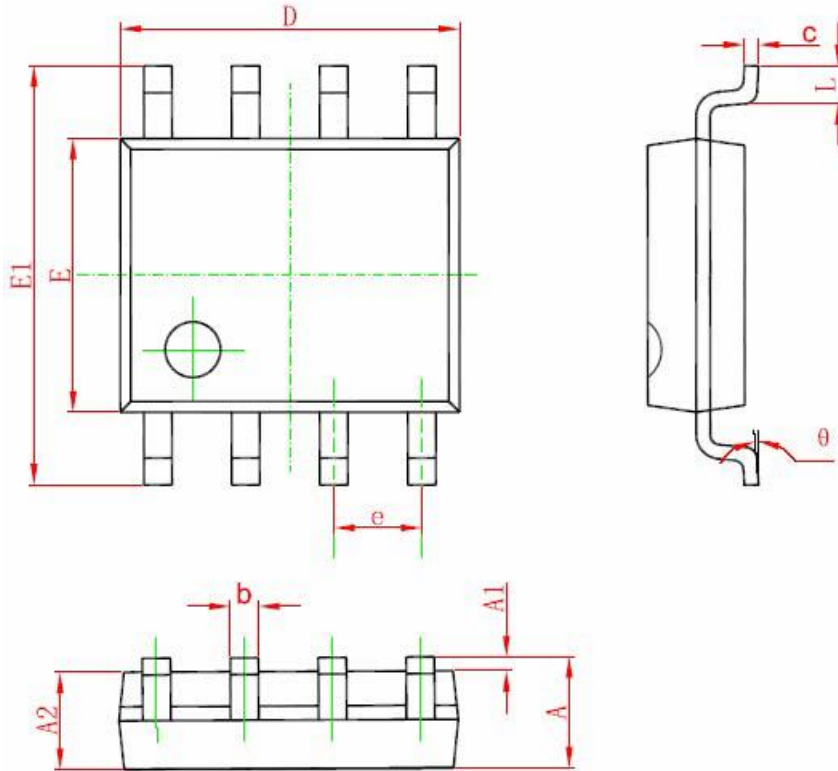

Symbol	Dimensions In Millimeters		Dimensions In Inches	
	Min	Max	Min	Max
A	1.350	1.750	0.053	0.069
A1	0.100	0.250	0.004	0.010
A2	1.350	1.550	0.053	0.061
b	0.330	0.510	0.013	0.020
c	0.170	0.250	0.006	0.010
D	4.700	5.100	0.185	0.200
E	3.800	4.000	0.150	0.157
E1	5.800	6.200	0.228	0.244
e	1.270 (BSC)		0.050 (BSC)	
L	0.400	1.270	0.016	0.050
θ	0°	8°	0°	8°