

Applications

- Wireless Infrastructure
- CATV / SATV / MoCA
- Point to Point
- Defense & Aerospace
- Test & Measurement Equipment
- General Purpose Wireless

Product Features

- DC – 4.5 GHz
- 15.2 dB Gain at 1 GHz
- +15.5 dBm P1dB at 1 GHz
- +32 dBm OIP3 at 1 GHz
- 3.7 dB Noise Figure
- Internally matched to 50 Ω
- Lead-free/RoHS-compliant SOT-89 Package

General Description

The ECG006B-G is a general-purpose buffer amplifier that offers high dynamic range in a low-cost surface-mount package. At 1000 MHz, the ECG006B-G typically provides 15.2 dB of gain, +32 dBm Output IP3, and +15.5 dBm P1dB.

The ECG006B-G consists of a Darlington-pair amplifier using the high reliability InGaP/GaAs HBT process technology and only requires DC-blocking capacitors, a bias resistor, and an inductive RF choke for operation. The device is ideal for wireless applications and is available in low-cost, surface-mountable plastic lead-free/RoHS-compliant SOT-89 packages. All devices are 100% RF and DC tested.

This broadband MMIC amplifier can be directly applied to various current and next generation wireless technologies. In addition, the ECG006B-G will satisfy general amplification requirements in the DC to 4.5 GHz frequency range such as CATV and mobile wireless.



SOT-89 Package Style

Functional Block Diagram

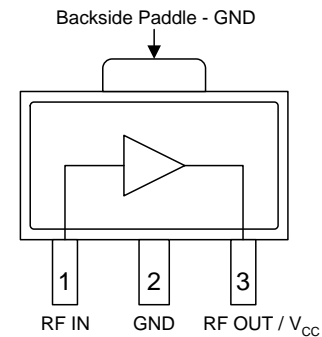

Pin Configuration

Pin No.	Label
1	RF IN
2	GND
3	RF OUT / V _{CC}
Backside Paddle	GND

Ordering Information

Part No.	Description
ECG006B-G	InGaP HBT Gain Block

Standard T/R size = 1000 pieces on a 7" reel

Absolute Maximum Ratings

Parameter	Rating
Storage Temperature	-55 to 150 °C
RF Input Power (Continuous)	+12 dBm
Device Current	150 mA

Operation of this device outside the parameter ranges given above may cause permanent damage.

Recommended Operating Conditions

Parameter	Min	Typ	Max	Units
T _{CASE}	-40		+85	°C
Junction Temperature			+160	°C

Electrical specifications are measured at specified test conditions. Specifications are not guaranteed over all recommended operating conditions.

Electrical Specifications

Test conditions unless otherwise noted: V_{SUPPLY} = +5 V, R_{BIAS} = 24.3 Ω, Temp.=+25 °C, 50 Ω System.

Parameter	Conditions	Min	Typ	Max	Units
Operational Bandwidth		DC		4500	MHz
Gain	Freq.=1000 MHz Pout=+2 dBm / Tone, Δf= 1 MHz		15.2		dB
Output P1dB			+15.5		dBm
Output IP3			+32		dBm
Gain	Freq.=2000 MHz Pout=+2 dBm / Tone, Δf= 1 MHz	13.3	14.6	17.2	dB
Input Return Loss			15		dB
Output Return Loss			13		dB
Output P1dB		+12	+15		dBm
Output IP3			+32		dBm
Noise Figure				4.0	
Device Voltage		+3.5	+3.9	+4.3	V
Device Current			45		mA
Thermal Resistance			131		°C / W

Typical Device RF Performance ⁽¹⁾

Test conditions unless otherwise noted: V_{SUPPLY} = +5 V, R_{BIAS} = 24.3 Ω, I_{CC} = 45 mA (typ.), Temp.=+25 °C, 50 Ω System.

Parameter	Typical								Units
	100	500	900	1900	2140	2400	3500	4500	
Frequency									MHz
Gain	15.8	15.6	15.3	14.6	14.5	14.4	13.7	12.7	dB
Input Return Loss	16	16	16	15	15	15	14	12	dB
Output Return Loss	14	14	14	13	13	13	12	9	dB
Output P1dB	+15.8	+15.4	+15.2	+15.0	+14.9	+14.6	+14		dBm
Output IP3 ⁽²⁾	+31	+31.5	+32	+30	+30	+29.6			dBm
Noise Figure	3.8	3.7	3.6	3.6	3.6	3.6			dB

Notes:

- Gain and return loss values presented above, and in the plots of the following section, are measured at the device level. Application specific performance values will differ in accordance with external components selected for the desired frequency band of operation. P1dB, OIP3 and NF data is measured using the application circuit shown on page 4.
- Pout= +2 dBm / tone, 1 MHz tone spacing.

Typical Device RF Performance ⁽¹⁾

Test conditions unless otherwise noted: $V_{SUPPLY} = +5\text{ V}$, $I_{CC} = 45\text{ mA}$ (typ.), $R_{BIAS} = 24.3\ \Omega$, $50\ \Omega$ System.

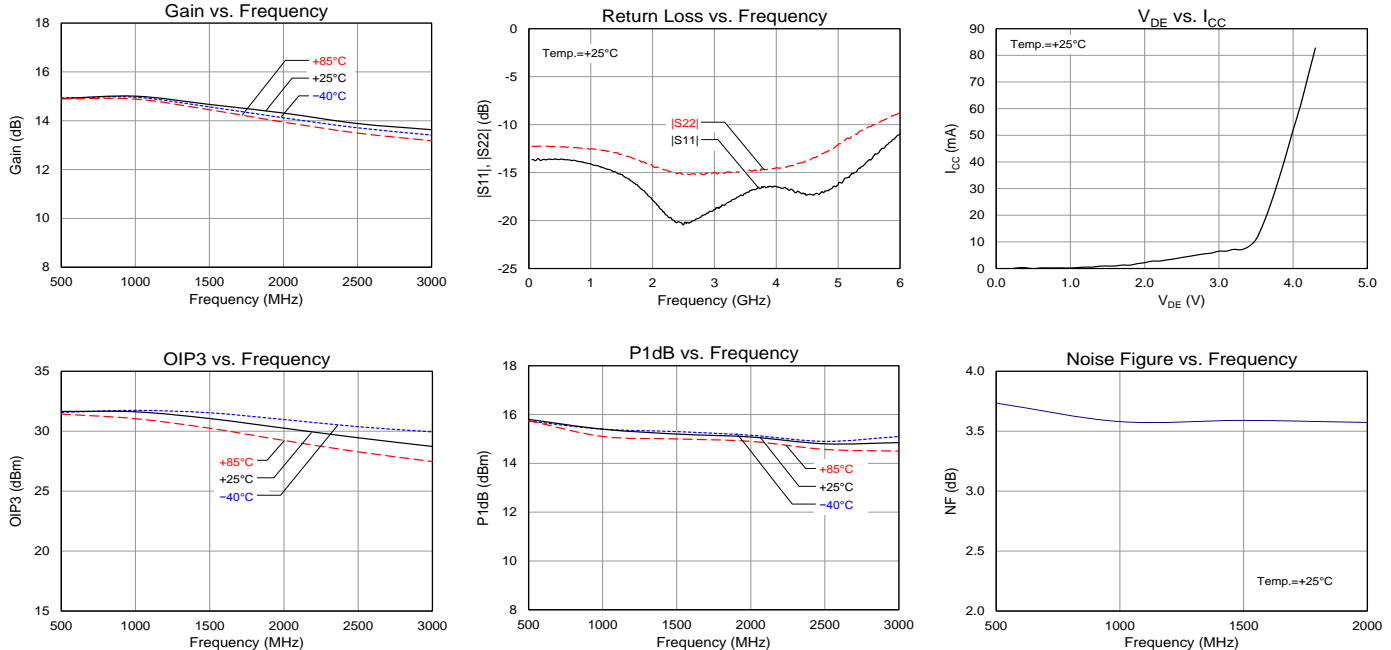

Notes:

1. Data is shown as device performance only. Actual implementation for the desired frequency band will be determined by external components shown in the application circuit.

Typical Device S-Parameters

Test Conditions: $V_{DEVICE} = +3.9\text{ V}$, $I_{CC} = 45\text{ mA}$, Temp. = +25 °C, Calibrated to device leads

Freq (MHz)	S11 (dB)	S11 (ang)	S21 (dB)	S21 (ang)	S12 (dB)	S12 (ang)	S22 (dB)	S22 (ang)
50	-16.18	-2.18	15.76	178.02	-18.89	-0.38	-14.36	-2.29
500	-16.13	-22.13	15.57	160.12	-18.77	-2.87	-14.40	-26.41
1000	-15.97	-44.58	15.21	141.76	-18.46	-5.33	-14.15	-51.57
1500	-15.79	-68.38	14.80	124.56	-17.94	-9.45	-13.78	-77.30
2000	-15.34	-96.24	14.64	108.50	-17.29	-14.37	-13.23	-104.15
2500	-14.99	-124.42	14.34	91.11	-16.69	-21.48	-12.79	-131.75
3000	-14.73	-153.90	14.02	74.20	-16.16	-29.16	-12.22	-160.58
3500	-14.29	174.59	13.65	56.77	-15.76	-38.37	-11.63	170.65
4000	-13.38	141.41	13.22	39.56	-15.49	-47.75	-10.44	143.61
4500	-11.80	110.87	12.66	22.19	-15.29	-57.59	-9.04	117.68
5000	-9.66	85.53	12.00	5.48	-15.28	-68.56	-7.50	96.34
5500	-7.85	63.77	11.20	-10.89	-15.43	-79.10	-6.12	76.71
6000	-6.37	47.01	10.36	-26.75	-15.69	-89.87	-4.95	59.58

Notes:

1. Device S-parameters are available for download off of the website at: www.triquint.com

Recommended Application Circuit

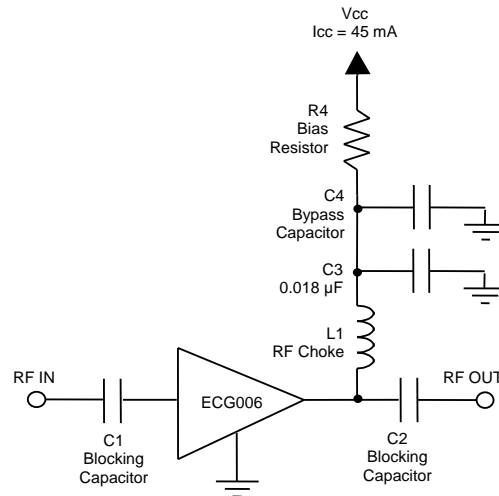
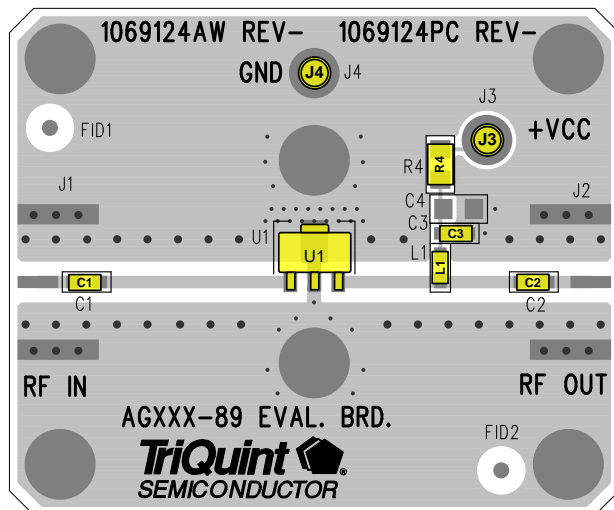

Notes:

1. See Evaluation Board PCB Information section for material and stack-up.

Bill of Material

Reference Des.	Value	Description
L1	39 nH	Wirewound Inductor, 0603
C1, C2	56 pF	Chip Capacitor, 0603
C3	0.018 μF	Chip Capacitor, 0603
C4	Do Not Place	
R4	24.3 Ω	1% Tolerance, 0805

Recommended Component Values

Frequency (MHz)	50	500	900	1900	2200	2500	3500
L1	820 nH	220 nH	68 nH	27 nH	22 nH	18 nH	15 nH
C1, C2, C3	.018 μF	1000 pF	100 pF	68 pF	68 pF	56 pF	39 pF

Recommended Bias Resistor Values

V _{SUPPLY} (V)	5	6	8	9	10	12
R4 (Ω)	24.4	46.7	91	113	136	180
Component Size	0805	0805	1210	1210	2010	2010

Notes:

1. The proper value for R4 is dependent upon the supply voltage and allows for bias stability over temperature. TriQuint recommends a minimum supply bias of +5 V. A 1% tolerance resistor is recommended.

Pin Configuration and Description

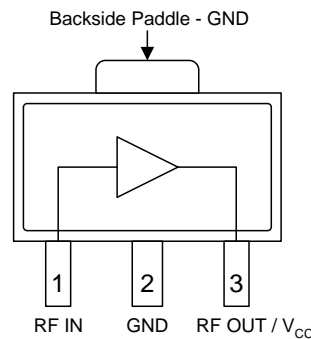

Pin No.	Label	Description
1	RF IN	RF input, matched to 50 ohms. External DC Block is required.
3	RF OUT / V _{CC}	RF output / DC supply, matched to 50 ohms. External DC Block, bias choke, and dropping resistor is required.
2, Backside Paddle	GND Paddle	RF/DC ground. Use recommended via pattern to minimize inductance and thermal resistance. See PCB Mounting Pattern for suggested footprint.

Evaluation Board PCB Information

TriQuint PCB 1069124 Material and Stack-up

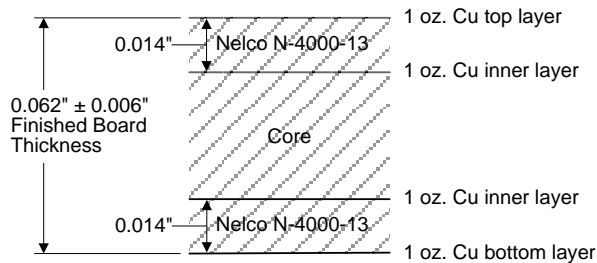

50 Ohm Line Dimensions: Width=0.028"
Spacing=0.036"

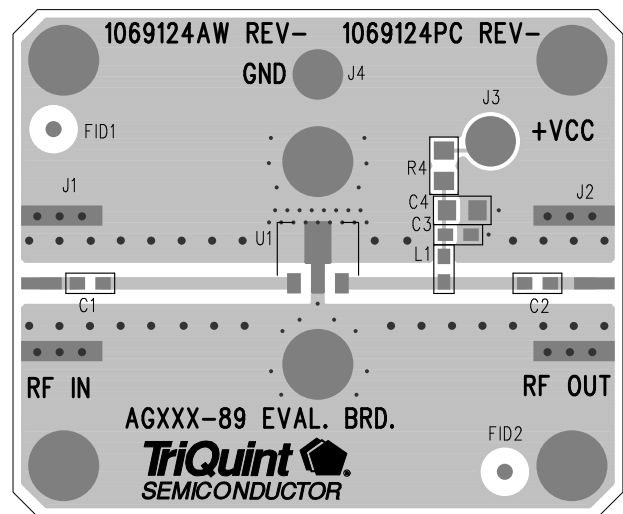

Package Marking and Dimensions

Marking: Part number – E006G
Lot code – XXXX

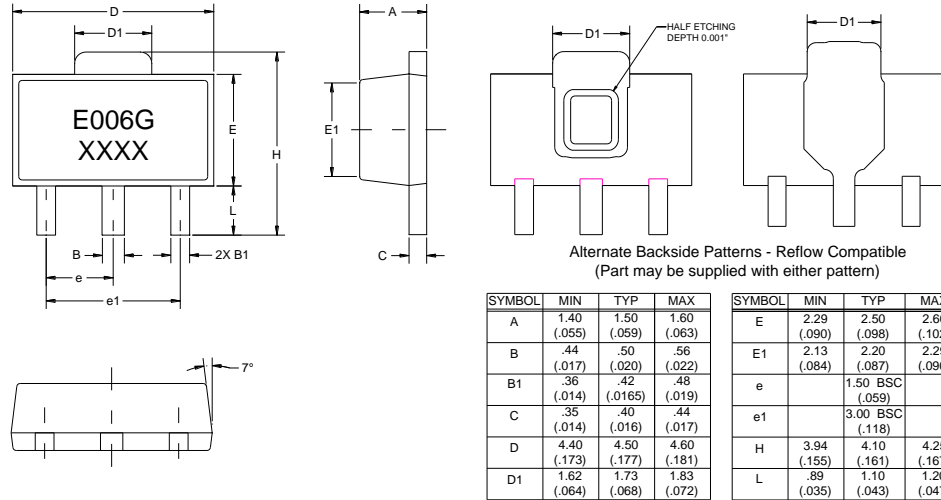

Notes:

1. All dimensions are in millimeters. Angles are in degrees.
2. Dimension and tolerance formats conform to ASME Y14.4M-1994.
3. The terminal #1 identifier and terminal numbering conform to JESD 95-1 SPP-012.
4. Contact plating: NiPdAu

PCB Mounting Pattern

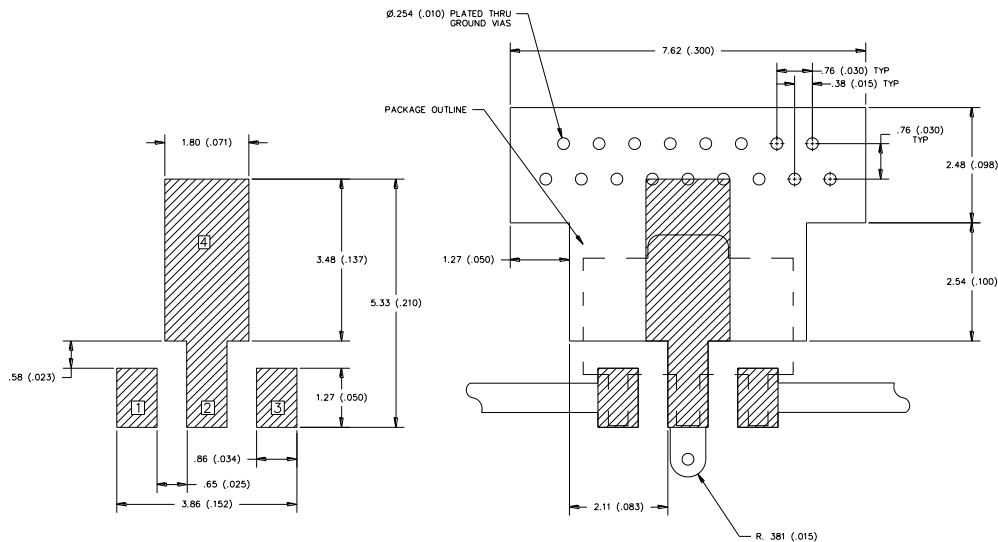

Notes:

1. All dimensions are in millimeters. Angles are in degrees.
2. Use 1 oz. copper minimum for top and bottom layer metal.
3. Vias are required under the backside paddle of this device for proper RF/DC grounding and thermal dissipation.
4. Do not remove or minimize via hole structure in the PCB. Thermal and RF grounding is critical.
5. We recommend a 0.35mm (#80/.0135") diameter bit for drilling via holes and a final plated thru diameter of 0.25 mm (0.10").
6. Ensure good package backside paddle solder attach for reliable operation and best electrical performance.

Product Compliance Information

ESD Sensitivity Ratings



Caution! ESD-Sensitive Device

ESD Rating: Class 1A
Value: ≥ 250 V to < 500 V
Test: Human Body Model (HBM)
Standard: ESDA/JEDEC Standard JS-001-2012

MSL Rating

MSL Rating: Level 3
Test: 260 °C convection reflow
Standard: JEDEC Standard IPC/JEDEC J-STD-020

Solderability

Compatible with both lead-free (260 °C maximum reflow temperature) and tin/lead (245 °C maximum reflow temperature) soldering processes.

Contact plating: NiPdAu

RoHS Compliance

This part is compliant with EU 2002/95/EC RoHS directive (Restrictions on the Use of Certain Hazardous Substances in Electrical and Electronic Equipment).

This product also has the following attributes:

- Lead Free
- Halogen Free (Chlorine, Bromine)
- Antimony Free
- TBBP-A (C₁₅H₁₂Br₄O₂) Free
- PFOS Free
- SVHC Free

Contact Information

For the latest specifications, additional product information, worldwide sales and distribution locations, and information about TriQuint:

Web: www.triquint.com **Tel:** +1.503.615.9000
Email: info-sales@triquint.com **Fax:** +1.503.615.8902

For technical questions and application information:

Email: sjcappliations.engineering@triquint.com

Important Notice

The information contained herein is believed to be reliable. TriQuint makes no warranties regarding the information contained herein. TriQuint assumes no responsibility or liability whatsoever for any of the information contained herein. TriQuint assumes no responsibility or liability whatsoever for the use of the information contained herein. The information contained herein is provided "AS IS, WHERE IS" and with all faults, and the entire risk associated with such information is entirely with the user. All information contained herein is subject to change without notice. Customers should obtain and verify the latest relevant information before placing orders for TriQuint products. The information contained herein or any use of such information does not grant, explicitly or implicitly, to any party any patent rights, licenses, or any other intellectual property rights, whether with regard to such information itself or anything described by such information.

TriQuint products are not warranted or authorized for use as critical components in medical, life-saving, or life-sustaining applications, or other applications where a failure would reasonably be expected to cause severe personal injury or death.