

#### Features

- High power output: 5.7 W typ
- High gain: 52.5 dB typ
- Low distortion: 0.2% typ
- Minimum requirement of external components
- Low power-on chattering noise: no need of additional capacitor
- Low impedance load:  $2 \Omega$  load for  $P_O = 8.8 \text{ W typ}$ , THD = 10%
- Protection circuitries for current surge, thermal shock, ASO (area of safety operation)

The ECG1423 and ECG1424 are designed as low-frequency, high-power amplifiers with a heat radiation fin.

The ECG1423 has the same characteristics as the ECG1424, except it has reversed pin assignment and biased mounting holes.

The reversed pin assignment is convenient for a stereo application and the biased mounting holes are provided to prevent both devices from mis-mounting.

The ECG1423 and ECG1424 can be operated with a very low impedance load,  $2 \Omega$ , and have protection circuitries against output short or surge current.

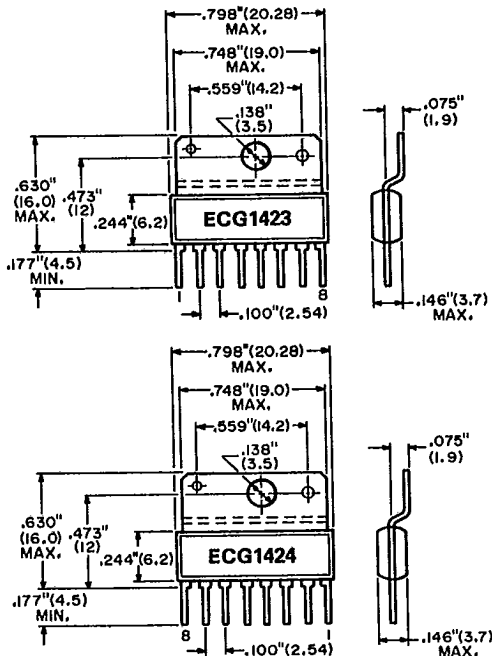

#### Pin Connection

- 1—Output
- 2— $V_{CC}$
- 3—Bootstrap
- 4—GND
- 5—Offset ADJ
- 6—Input
- 7—NFB Bypass
- 8—Inv. Input

#### Absolute Maximum Ratings ( $T_A = 25^\circ\text{C}$ )

Characteristic	Symbol	Rating	Unit
Power Supply Voltage	$V_{CC}$	+ 18	V
Surge Voltage	$V_{CC} (S)$	+ 40*	V
Output Current	$I_O$ (peak)	4.5	A
Power Dissipation	$P_D$	7.5**	W
Storage Temperature	$T_{stg}$	- 65 to + 150	$^\circ\text{C}$

\*  $t_g \leq 0.2 \text{ sec}$

\*\*  $T_C \leq +75^\circ\text{C}$

## Schematic Circuit

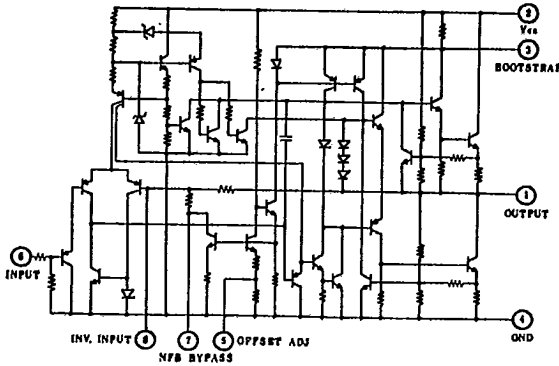

## Recommended Operating Conditions

Characteristics	Symbol	Rating	Unit
Supply Voltage	$V_{CC}$	+9 to +16	V
Operating Temperature	$T_{OP}$	-20 to +75	°C

Electrical Characteristics ( $T_C = +25^\circ\text{C}$ ,  $V_{CC} = 13.2\text{ V}$ ,  $R_L = 4\ \Omega$ ,  $f = 1\text{ kHz}$  unless otherwise noted)

Characteristics	Symbol	Test Condition	Min	Typ	Max	Unit
Power Supply Current	$I_Q$	$V_{IN} = 0\text{ V}$	--	30	60	mA
Voltage Gain	$A_V$	$P_{O1} = 1\text{ W}$	50	52.5	55	dB
Output Power	$P_{O1}$	THD = 10%	5.0	5.7	--	W
Output Power	$P_{O2}$	THD = 10%, $R_L = 2\ \Omega$	--	8.8	--	W
Total Harmonic Distortion	THD <sub>1</sub>	$P_{O1} = 1\text{ W}$	--	0.2	--	%
Total Harmonic Distortion	THD <sub>2</sub>	$P_{O1} = 1\text{ W}$ , $R_L = 2\ \Omega$	--	0.2	--	%
Output Noise Voltage	$V_{NO}$	$R_g = 10\text{ k}\Omega$ , BW = 20 Hz to 20 kHz	--	1.0	2.0	mV
Input Resistance	$R_{IN}$		--	50	--	k $\Omega$

## Test Circuit

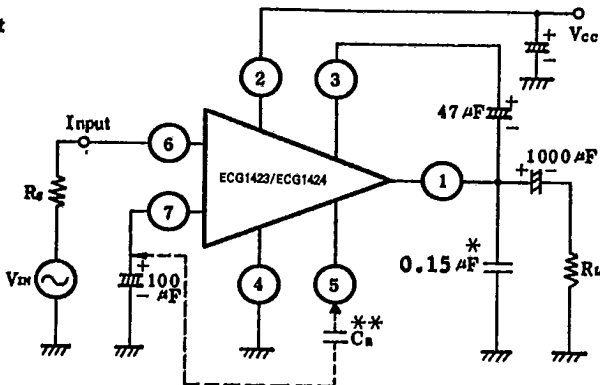

\* Use a non-resonant polyester-film capacitor.

\*\* Used for rejection of power supply ripples.

# Application Information

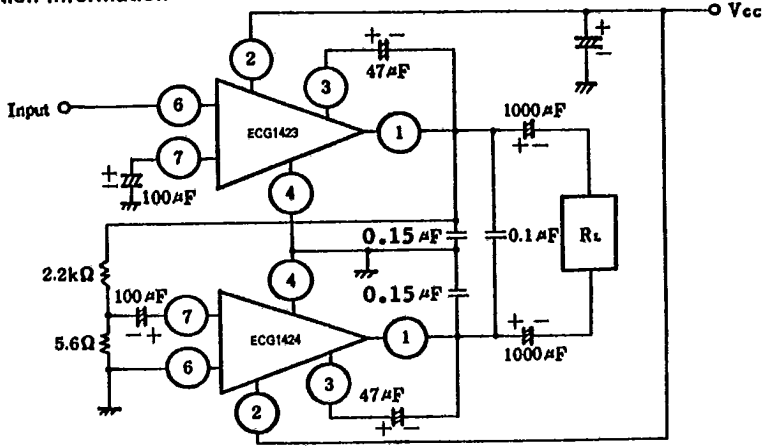

BTL (Balanced Transformerless) Application Example

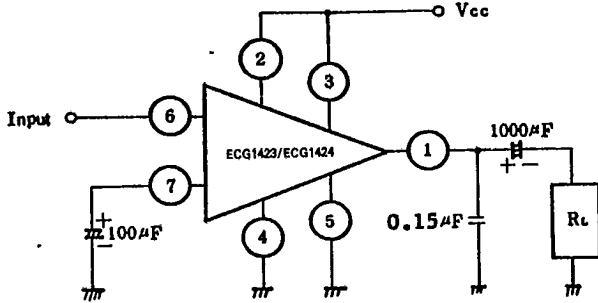

Simple Amplifier Application Example