

ECM-KA

AMD G-Series SoC Platform
3.5" Micro Module

Quick Installation Guide



2nd Ed – 01 September 2013

FCC Statement



THIS DEVICE COMPLIES WITH PART 15 FCC RULES. OPERATION IS SUBJECT TO THE FOLLOWING TWO CONDITIONS:

(1) THIS DEVICE MAY NOT CAUSE HARMFUL INTERFERENCE.

(2) THIS DEVICE MUST ACCEPT ANY INTERFERENCE RECEIVED INCLUDING INTERFERENCE THAT MAY CAUSE UNDESIRE OPERATION.

THIS EQUIPMENT HAS BEEN TESTED AND FOUND TO COMPLY WITH THE LIMITS FOR A CLASS "A" DIGITAL DEVICE, PURSUANT TO PART 15 OF THE FCC RULES.

THESE LIMITS ARE DESIGNED TO PROVIDE REASONABLE PROTECTION AGAINST HARMFUL INTERFERENCE WHEN THE EQUIPMENT IS OPERATED IN A COMMERCIAL ENVIRONMENT. THIS EQUIPMENT GENERATES, USES, AND CAN RADIATE RADIO FREQUENCY ENERGY AND, IF NOT INSTALLED AND USED IN ACCORDANCE WITH THE INSTRUCTION MANUAL, MAY CAUSE HARMFUL INTERFERENCE TO RADIO COMMUNICATIONS.

OPERATION OF THIS EQUIPMENT IN A RESIDENTIAL AREA IS LIKELY TO CAUSE HARMFUL INTERFERENCE IN WHICH CASE THE USER WILL BE REQUIRED TO CORRECT THE INTERFERENCE AT HIS OWN EXPENSE.

A Message to the Customer

Avalue Customer Services

Each and every Avalue's product is built to the most exacting specifications to ensure reliable performance in the harsh and demanding conditions typical of industrial environments. Whether your new Avalue device is destined for the laboratory or the factory floor, you can be assured that your product will provide the reliability and ease of operation for which the name Avalue has come to be known.

Your satisfaction is our primary concern. Here is a guide to Avalue's customer services. To ensure you get the full benefit of our services, please follow the instructions below carefully.

Technical Support

We want you to get the maximum performance from your products. So if you run into technical difficulties, we are here to help. For the most frequently asked questions, you can easily find answers in your product documentation. These answers are normally a lot more detailed than the ones we can give over the phone. So please consult the user's manual first.

To receive the latest version of the user's manual; please visit our Web site at:

<http://www.avalue.com.tw/>

ECM-KA Quick Installation Guide

If you still cannot find the answer, gather all the information or questions that apply to your problem, and with the product close at hand, call your dealer. Our dealers are well trained and ready to give you the support you need to get the most from your Avalue's products. In fact, most problems reported are minor and are able to be easily solved over the phone. In addition, free technical support is available from Avalue's engineers every business day. We are always ready to give advice on application requirements or specific information on the installation and operation of any of our products. Please do not hesitate to call or e-mail us.

Headquarters and Branch

Avalue Technology Inc.

7F, 228, Lian-cheng Road, Zhonghe Dist.,
New Taipei City 235, Taiwan
Tel: +886-2-8226-2345
Fax: +886-2-8226-2777
Information: sales@avalue.com.tw
Service: service@avalue.com.tw

BCM Advanced Research BCM Advanced Research an Avalue Company

7 Marconi, Irvine, CA92618
Tel: +1-949-470-1888
Fax: +1-949-470-0971
Information: BCMSales@bcmcom.com
Web: www.bcmcom.com

Avalue China

Avalue Technology Inc.

Room 805, Building 9, No.99 Tianzhou Rd.,
Caohejing Development Area,
Xuhui District, Shanghai
Tel: +86-21-5169-3609
Fax: +86-21-5445-3266
Information: sales.china@avalue.com.cn
Service: service@avalue.com.tw

Avalue USA

Avalue Technology Inc.

9 Timber Lane, Marlboro, NJ 07746-1443
Tel: (732) 414-6500
Fax: (732) 414-6501
Information: sales@avalue-usa.com
Service: support@avalue-usa.com

Avalue Europe

Avalue Europe A/S

Moelledalen 22C, 3140
Aalsgaarde, Denmark
Tel: +45-7025-0310
Fax: +45-4975-5026
Information: sales.europe@avalue.com.tw
Service: service.europe@avalue.com.tw

Avalue Japan

Avalue Technology Inc.

3F Ishiyama-Bldg, 1-6-1 Taito,
Taito-ku, Tokyo 110-0016 Japan
Tel : +81-3-5807-2321
Fax : +81-3-5807-2322
Information : sales.japan@avalue.com.tw
Service : service@avalue.com.tw

Content

1. Getting Started	5
1.1 Safety Precautions	5
1.2 Packing List.....	5
2. Hardware Configuration	6
2.1 Product Overview	7
2.2 Jumper and Connector List	9
2.3 Setting Jumpers & Connectors.....	11
2.3.1 Clear CMOS (JPCMOS1).....	11
2.3.2 Touch connector select jumper (JTOUCH_SEL) (option).....	11
2.3.3 LCD backlight brightness adjustment (JVR1).....	12
2.3.4 AT/ ATX Input power select (JAT1).....	12
2.3.5 COM 1 pin 9 signal select (JRI1).....	13
2.3.6 5VSB connector in ATX (PWR_SB1)	13
2.3.7 Battery connector (BAT1).....	14
2.3.8 CPU fan connector (CPU_FAN1)	14
2.3.9 System fan connector (SYS_FAN1)	15
2.3.10 COM 1 RS-422-485 mode (J422/1)	15
2.3.11 LCD inverter connector (JBKL1)	16
2.3.12 Low pin count connector (JLPC1)	16
2.3.13 Audio connector (JAUDIO1).....	17
2.3.13.1 Signal Description – Audio connector (JAUDIO1).....	17
2.3.14 Serial port 2 connector (JCOM2).....	18
2.3.15 General purpose I/O connector (DIO1)	18
2.3.16 Miscellaneous setting connector (JFP1).....	19
2.3.17 SPI connector (JSPI1).....	19
2.3.18 EC_Program (EC_SPI1)	20
2.3.19 Power connector (PWR_IN1)	20
2.3.20 HDD power connector (HD_PWR1)	21
2.3.21 Touch connector (JTOUCH1) (option).....	21
2.3.22 LVDS connector (JLVDS1).....	22
2.3.23 On-board box header for USB2.0 (JUSB1)	23
2.3.24 On-board box header for USB2.0 (JUSB2)	23
2.3.25 On-board box header for USB2.0 (JUSB3)	24
2.3.26 PS/2 keyboard & mouse connector (JKBMS).....	24

1. Getting Started

1.1 Safety Precautions

Warning!



Always completely disconnect the power cord from your chassis whenever you work with the hardware. Do not make connections while the power is on. Sensitive electronic components can be damaged by sudden power surges. Only experienced electronics personnel should open the PC chassis.

Caution!



Always ground yourself to remove any static charge before touching the CPU card. Modern electronic devices are very sensitive to static electric charges. As a safety precaution, use a grounding wrist strap at all times. Place all electronic components in a static-dissipative surface or static-shielded bag when they are not in the chassis.

1.2 Packing List

Before you begin installing your single board, please make sure that the following materials have been shipped:

- 1 x 3.5" ECM-KA Micro Module
- 1 x Quick Installation Guide for ECM-KA
- 1 x AUX-032 daughter board W/Audio/4USB
- 1 x DVD-ROM contains the followings:
 - User's Manual (this manual in PDF file)
 - Ethernet driver and utilities
 - VGA drivers and utilities
 - Audio drivers and utilities
- 1 x Cable set contains the followings:
 - 1 x Audio cable (12pin,2.0 pitch)
 - 1 x USB 2.0 cable (10P/2.0mm-10P/2.0mm)
 - 1 x Serial ATA cable (7-pin, standard)
 - 1 x Wire SATA power cable (15-pin,4P/2.5mm)
 - 1 x Flat cable 9P(M)-PHD 10P/2.0mm)
- 3M foam (VHB-4622 10mm*20mm*1.1mm)

2. Hardware Configuration

2.1 Product Overview

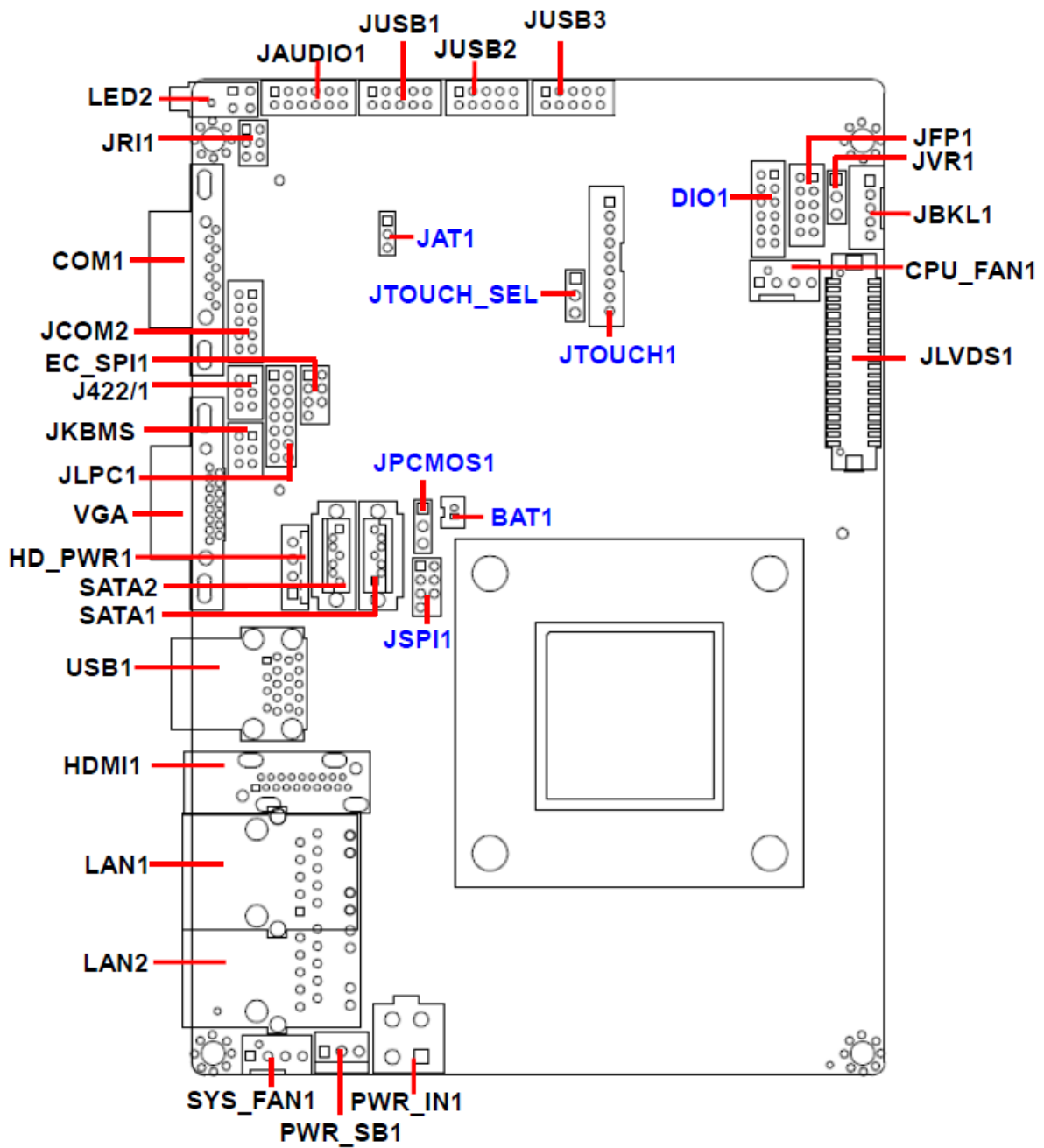

ECM-KA Quick Installation Guide

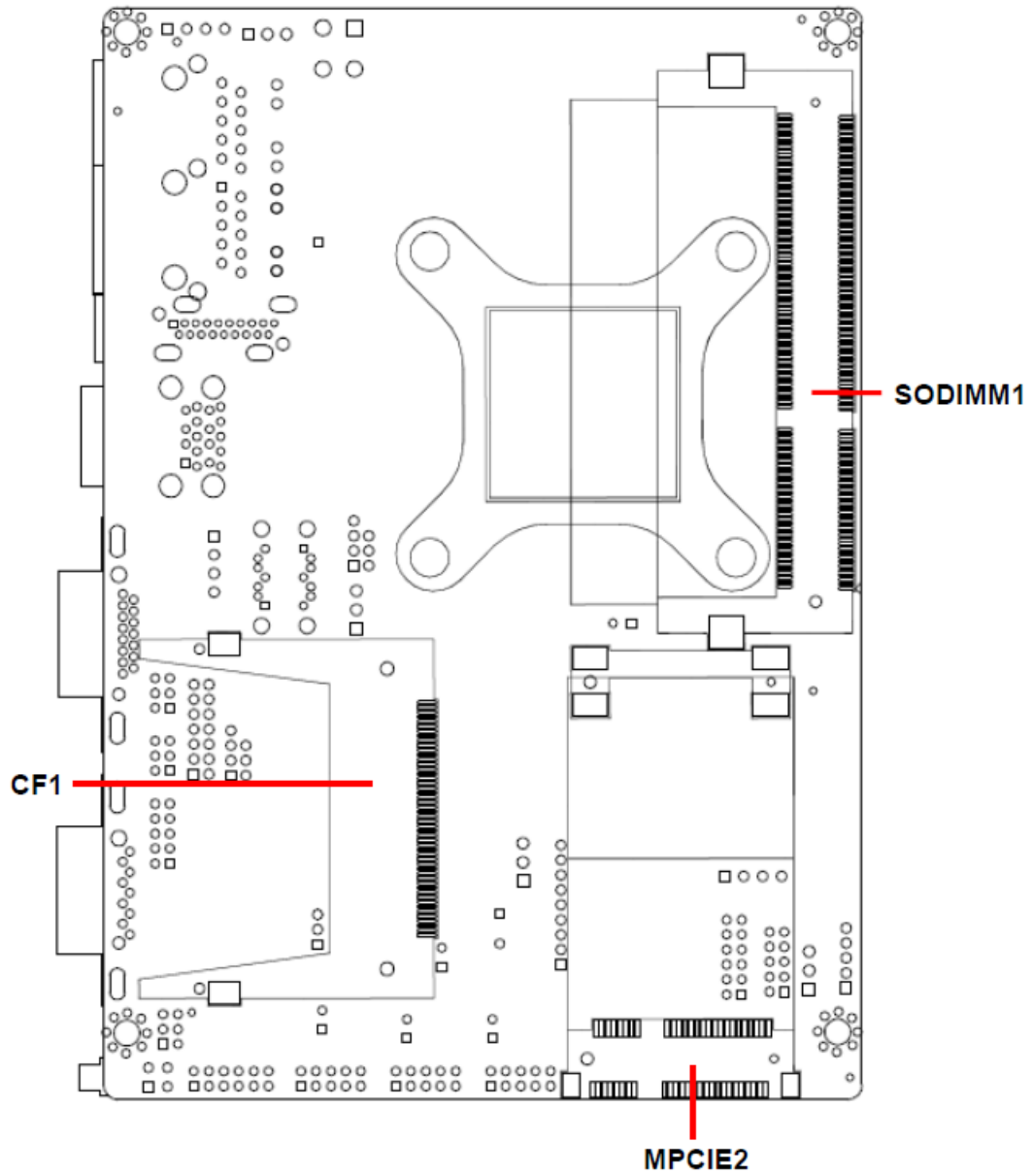

ECM-KA Quick Installation Guide

2.2 Jumper and Connector List

You can configure your board to match the needs of your application by setting jumpers. A jumper is the simplest kind of electric switch.

It consists of two metal pins and a small metal clip (often protected by a plastic cover) that slides over the pins to connect them. To “close” a jumper you connect the pins with the clip. To “open” a jumper you remove the clip. Sometimes a jumper will have three pins, labeled 1, 2, and 3. In this case, you would connect either two pins.

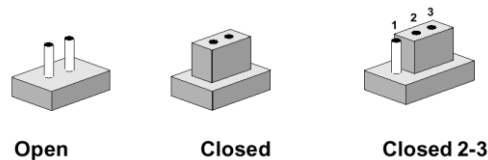

The jumper settings are schematically depicted in this manual as follows:



A pair of needle-nose pliers may be helpful when working with jumpers.

Connectors on the board are linked to external devices such as hard disk drives, a keyboard, or floppy drives. In addition, the board has a number of jumpers that allow you to configure your system to suit your application.

If you have any doubts about the best hardware configuration for your application, contact your local distributor or sales representative before you make any changes.

The following tables list the function of each of the board’s jumpers and connectors.

Jumpers

Label	Function	Note
JPCMOS1	Clear CMOS	3 x 1 header, pitch 2.54 mm
JTOUCH_SEL	Touch connector select jumper (option)	3 x 1 header, pitch 2.54 mm
JVR1	LCD backlight brightness adjustment	3 x 1 header, pitch 2.54 mm
JRI1	COM 1 pin 9 signal select	3 x 2 header, pitch 2.00 mm
JAT1	AT/ ATX Input power select	3 x 1 header, pitch 2.00 mm

Connectors

Label	Function	Note
JTOUCH1	Touch connector (option)	9 x 1 wafer, pitch 2.00 mm
BAT1	Battery connector	2 x 1 wafer, pitch 1.25 mm
CPU_FAN1	CPU fan connector	4 x 1 wafer, pitch 2.54 mm

ECM-KA Quick Installation Guide

HDMI1	HDMI connector	
J422/1	COM 1 RS-422-485 mode	2 x 3 wafer, pitch 2.00 mm
JAUDIO1	Audio connector	2 x 6 wafer, pitch 2.00 mm
JBKL1	LCD inverter connector	5 x 1 wafer, pitch 2.00 mm
COM1	Serial port 1 connector	D-sub 9-pin, male
JCOM2	Serial port 2 connector	2 x 5 wafer, pitch 2.00 mm
DIO1	General purpose I/O connector	2 x 6 wafer, pitch 2.00 mm
JFP1	Miscellaneous setting connector	2 x 5 wafer, pitch 2.00 mm
JLPC1	Low pin count connector	7 x 2 header, pitch 2.00 mm
JLVDS1	LVDS connector	20 x 2 header, pitch 1.25 mm
JSPI1	SPI connector	4 x 2 header, pitch 2.00 mm
USB1	On-board connector for USB3.0 x 2	
JUSB1	On-board box header for USB2.0	2 x 5 wafer, pitch 2.00 mm
JUSB2	On-board box header for USB2.0	2 x 5 wafer, pitch 2.00 mm
JUSB3	On-board box header for USB2.0	2 x 5 wafer, pitch 2.00 mm
HD_PWR1	HDD power connector	1 x 4 wafer, pitch 2.50 mm
LAN1/2	RJ-45 Ethernet connector	
LED2	LED connector	
PWR_SB1	5VSB connector in ATX	3 x 1 wafer, pitch 2.54 mm
PWR_IN1	Power connector	2 x 2 wafer, pitch 4.20 mm
JKBMS	PS/2 keyboard & mouse connector	2 x 3 wafer, pitch 2.00 mm
EC_SPI1	EC_Program	4 x 2 header, pitch 2.00 mm
SATA1/2	Serial ATA connector 1/2	
SYS_FAN1	System fan connector	4 x 1 wafer, pitch 2.54 mm
VGA	VGA connector	D-sub 15-pin, female
MPCIE2	Mini-PCI connector	
SODIMM1	DDR3 SODIMM connector	
CF1	CF card slot	

Note:

1. USB 3.0 ports would not be activated unless USB 3.0 driver is loaded in Windows.
2. In order to facilitate USB 3.0 ports, no matter in a system or single board, please attach either PS2 keyboard/mouse or USB 2.0 keyboard/mouse to on-board USB 2.0 pin header in advance in order to install chip driver (USB 3.0 driver is included) in Windows.

2.3 Setting Jumpers & Connectors

2.3.1 Clear CMOS (JPCMOS1)

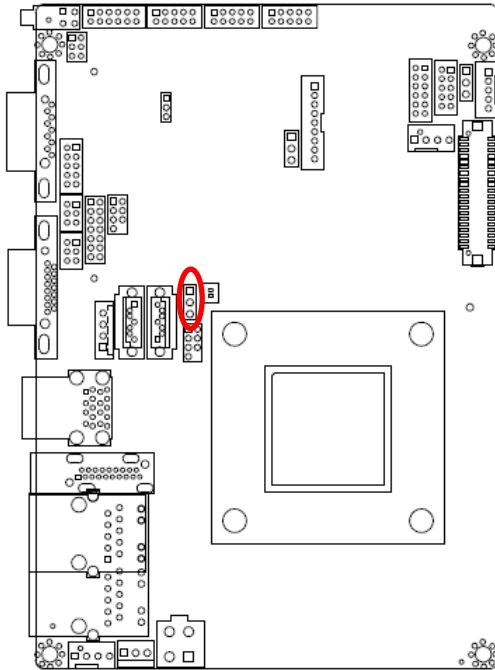

Normal*

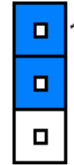

CMOS Clear

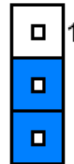

* Default

2.3.2 Touch connector select jumper (JTOUCH_SEL) (option)

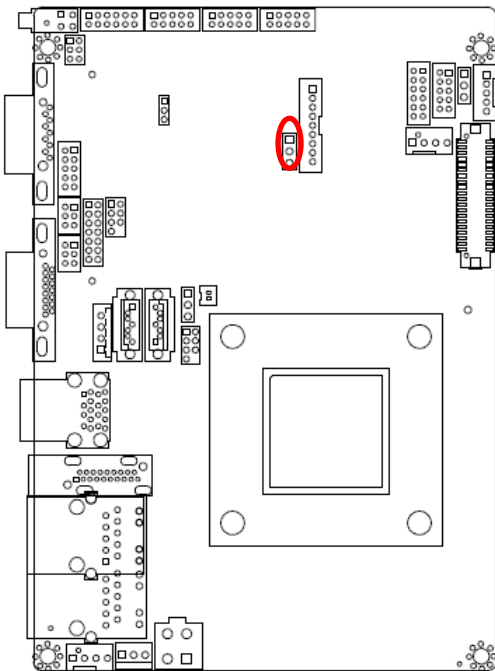

5W*

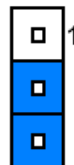

4/8W

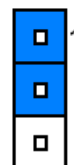

* Default

ECM-KA Quick Installation Guide

2.3.3 LCD backlight brightness adjustment (JVR1)

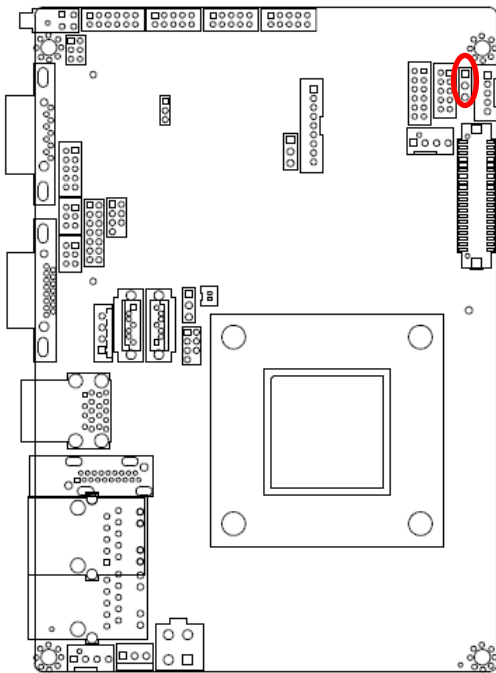

PWM mode*

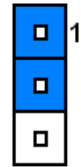

DC mode

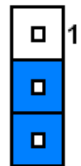

* Default

2.3.4 AT/ ATX Input power select (JAT1)

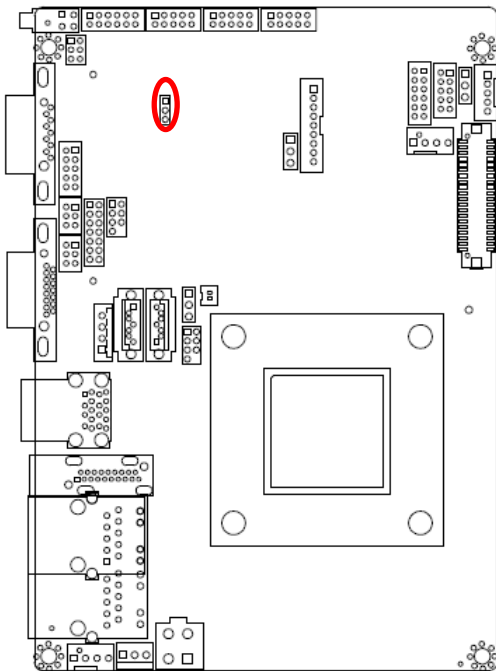

AT*

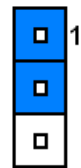

ATX

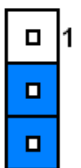

* Default

ECM-KA Quick Installation Guide

2.3.5 COM 1 pin 9 signal select (JRI1)

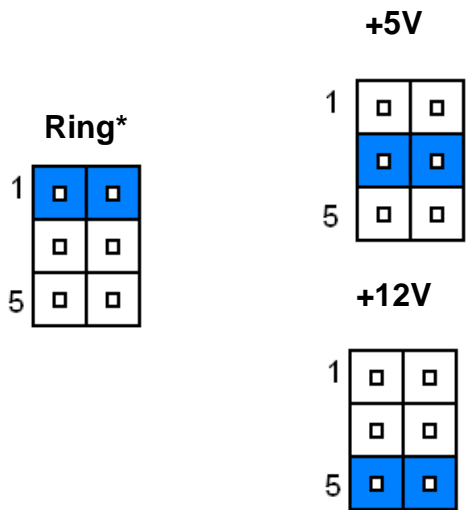
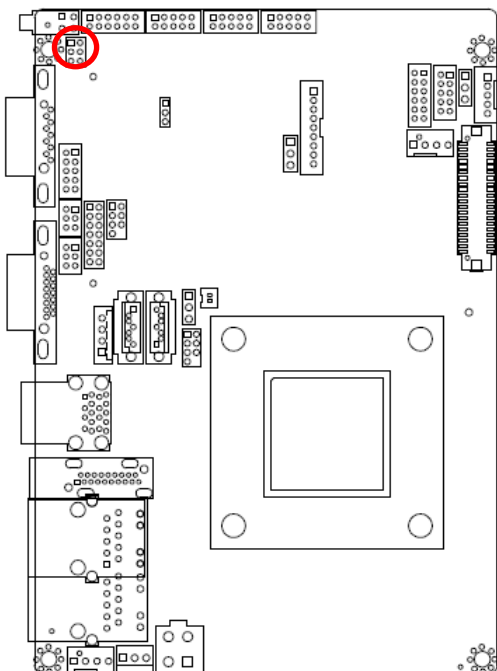

* Default

2.3.6 5VSB connector in ATX (PWR_SB1)

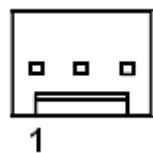
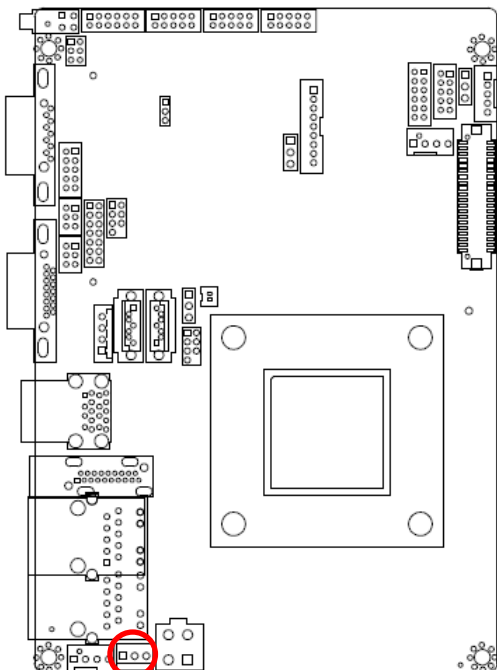

Signal	PIN
PS_ON#	1
GND	2
+V5A_ATX_SB	3

ECM-KA Quick Installation Guide

2.3.7 Battery connector (BAT1)

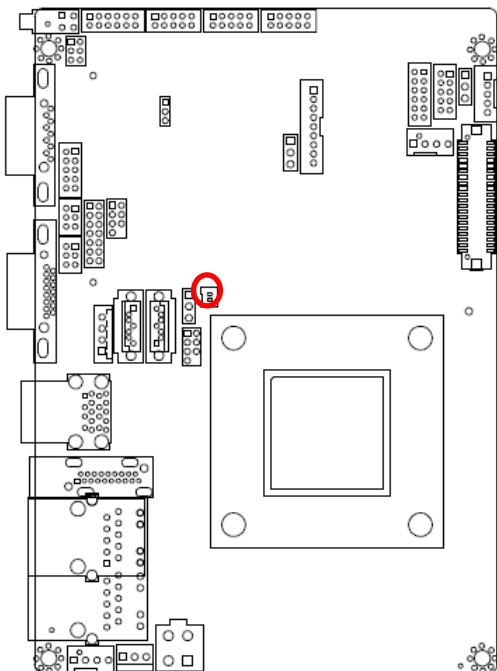

Signal	PIN
GND	2
+3.3V	1

2.3.8 CPU fan connector (CPU_FAN1)

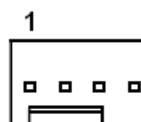
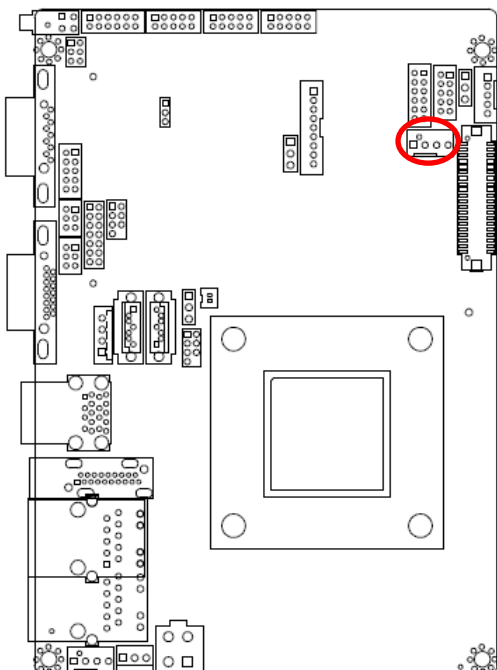

Signal	PIN
GND	1
+12V	2
EC_TACH0	3
FAN_PWM0	4

ECM-KA Quick Installation Guide

2.3.9 System fan connector (SYS_FAN1)

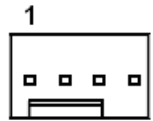
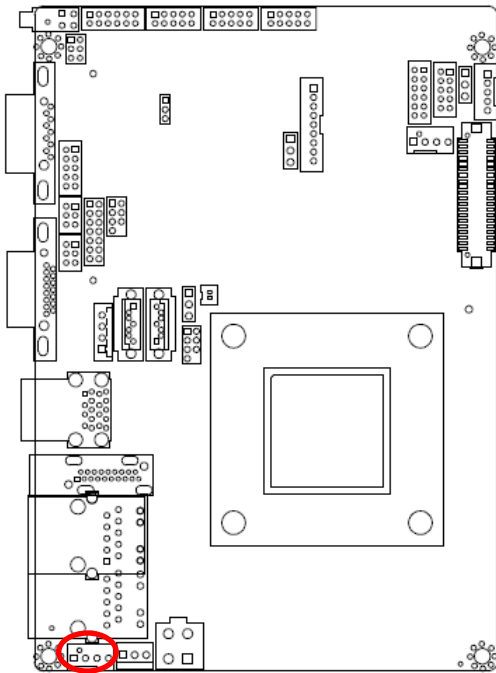

Signal	PIN
GND	1
+12V	2
EC_TACH1	3
FAN_PWM1	4

2.3.10 COM 1 RS-422-485 mode (J422/1)

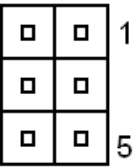
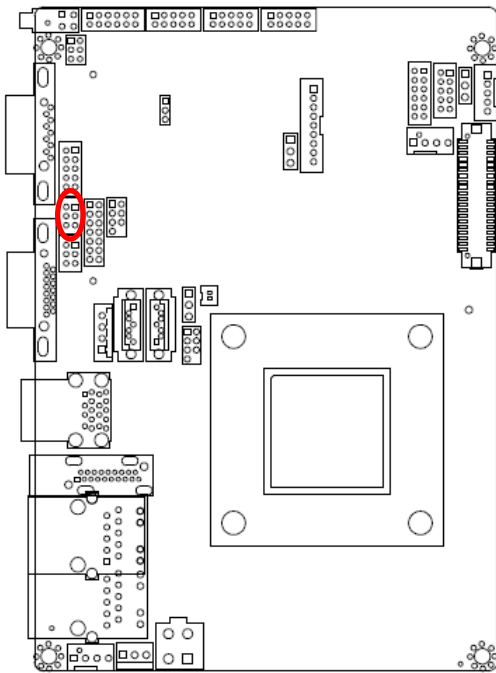

Signal	PIN	PIN	Signal
485TX.RX-/422TX-	2	1	422RX+
485TX.RX+/422TX+	4	3	422RX-
5V	6	5	GND

Note:
 J422/485 is available after modify the mode of COM1 in BIOS setting

ECM-KA Quick Installation Guide

2.3.11 LCD inverter connector (JBKL1)

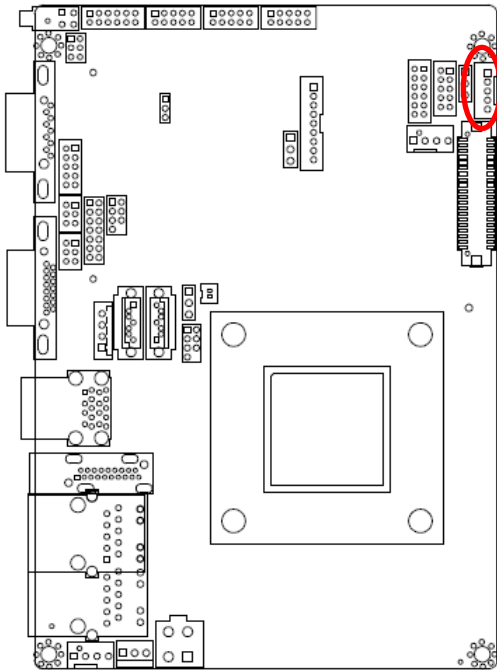

Signal	PIN
+12V	1
GND	2
BKLEN	3
BRIADJ	4
+5V	5

2.3.12 Low pin count connector (JLPC1)

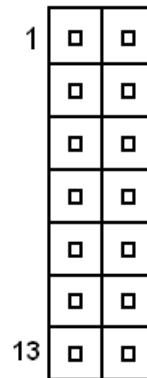
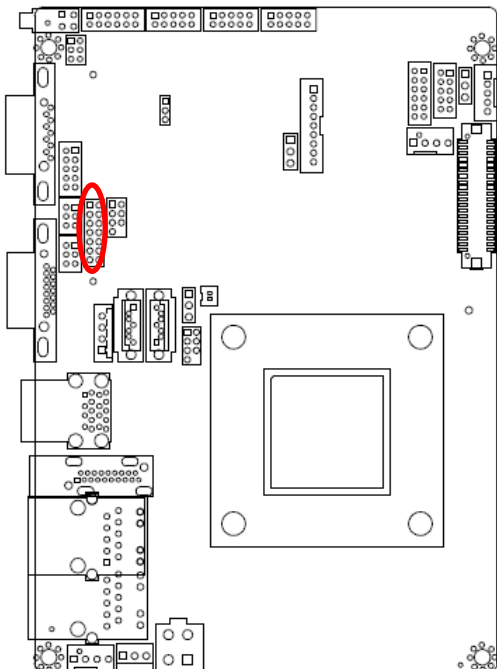

Signal	PIN	PIN	Signal
LPC_AD0	1	2	+3.3V
LPC_AD1	3	4	LPC_RST#
LPC_AD2	5	6	LPC_FRAME#
LPC_AD3	7	8	LPC_CLK1
SERIRQ	9	10	GND
+V5S	11	12	GND
+V5A	13	14	LDRQ0#

ECM-KA Quick Installation Guide

2.3.13 Audio connector (JAUDIO1)

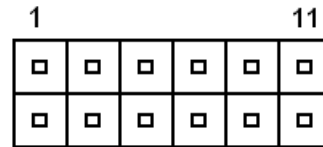
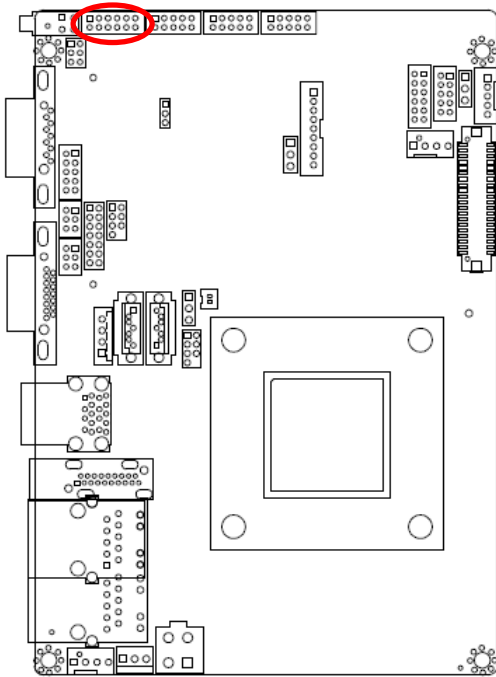

Signal	PIN	PIN	Signal
FRONT-L-OUT	1	2	FRONT-R-OUT
GND	3	4	GND
LINE1-L-IN	5	6	LINE1-R-IN
MIC1-L-IN	7	8	MIC1-R-IN
LINE1-JD	9	10	FRONT-JD
GND	11	12	MIC1-JD

2.3.13.1 Signal Description – Audio connector (JAUDIO1)

Signal	Signal Description
LINE1_JD	AUDIO IN (LINE_RIN/LIN)sense pin
FRONT_JD	AUDIO Out(ROUT/LOUT) sense pin
MIC1_JD	MIC IN (MIC_RIN/LIN) sense pin

ECM-KA Quick Installation Guide

2.3.14 Serial port 2 connector (JCOM2)

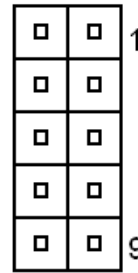
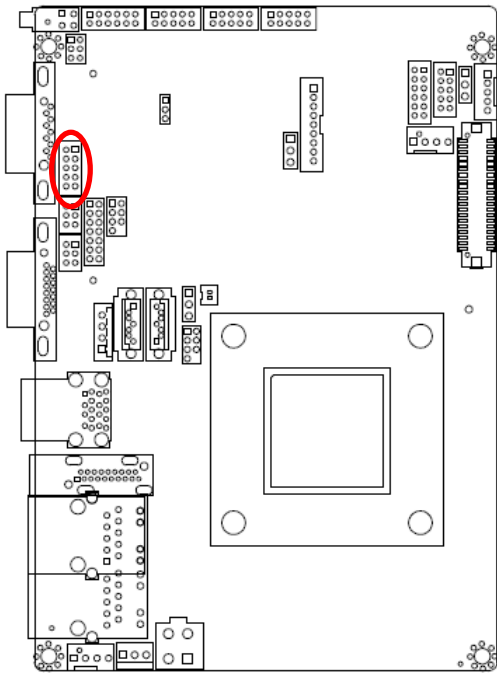

Signal	PIN	PIN	Signal
RXDD2	2	1	DCD2
DTR2	4	3	TXDD2
DSR2	6	5	GND
CTS2	8	7	RTS2
NC	10	9	RI2

2.3.15 General purpose I/O connector (DIO1)

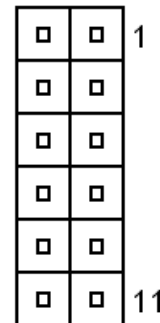
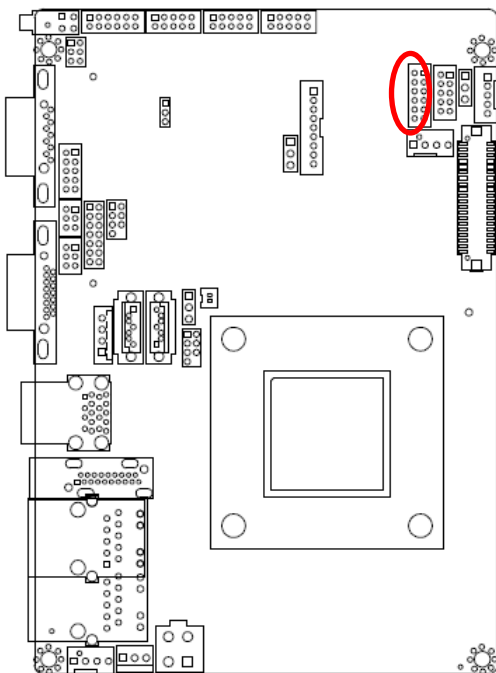

Signal	PIN	PIN	Signal
DO0	2	1	DI0
DO1	4	3	DI1
DO2	6	5	DI2
DO3	8	7	DI3
SMB_CLK_9555	10	9	SMB_DATA_9555
GND	12	11	+V5S_DIO

ECM-KA Quick Installation Guide

2.3.16 Miscellaneous setting connector (JFP1)

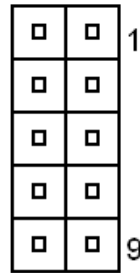
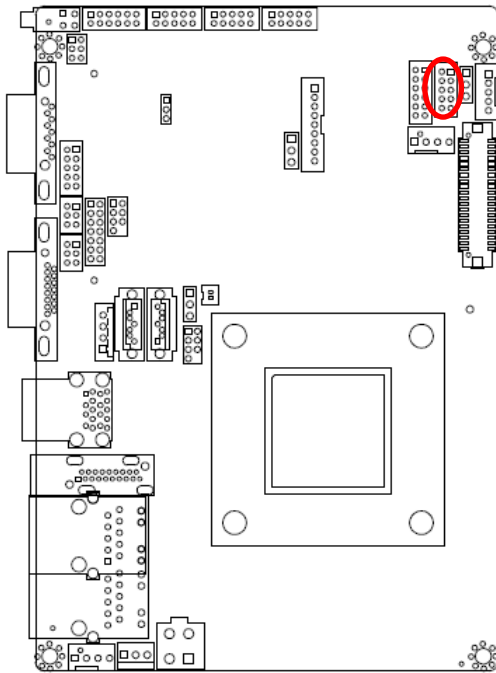

Signal	PIN
PWBT	1
	2
RST#	3
	4
PWR-LED-	5
PWR-LED+	6
HDD-LED+	7
HDD-LED-	8
COPEN#	9
	10

2.3.17 SPI connector (JSPI1)

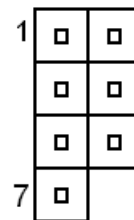
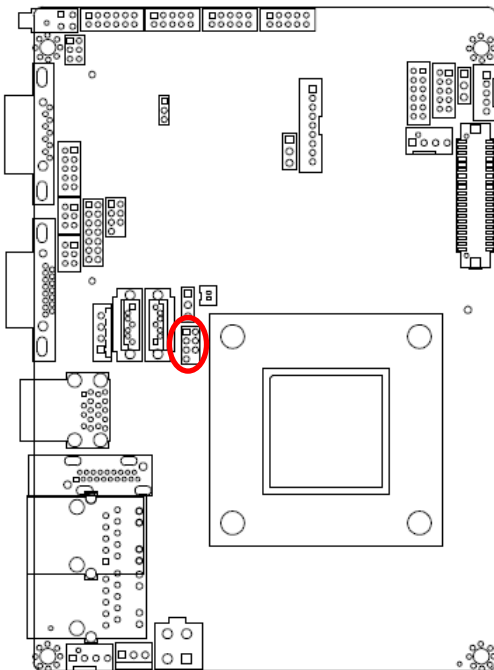

Signal	PIN	PIN	Signal
+3.3V	1	2	GND
SPI_CS#	3	4	SPI_CLK
SPI_DI	5	6	SPI_DO
SPI_HOLD#	7		

ECM-KA Quick Installation Guide

2.3.18 EC_Program (EC_SPI1)

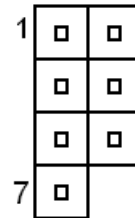
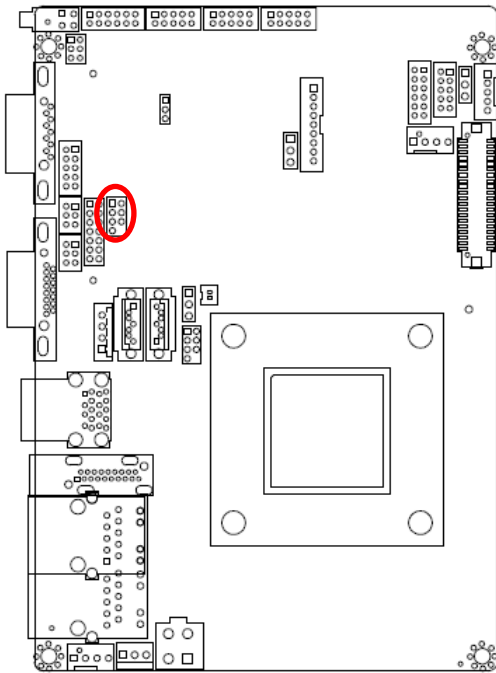

Signal	PIN	PIN	Signal
+VSPI_EC	1	2	GND
EC_FSCE#	3	4	EC_FSCK
EC_FMISO	5	6	EC_FMOSI
EC_HOLD#	7		

2.3.19 Power connector (PWR_IN1)

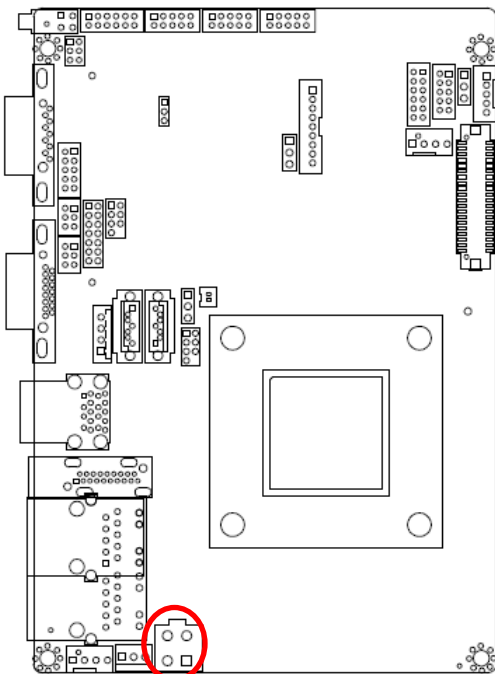

Signal	PIN	PIN	Signal
+V_DCIN	4	3	+V_DCIN
GND	2	1	GND

ECM-KA Quick Installation Guide

2.3.20 HDD power connector (HD_PWR1)

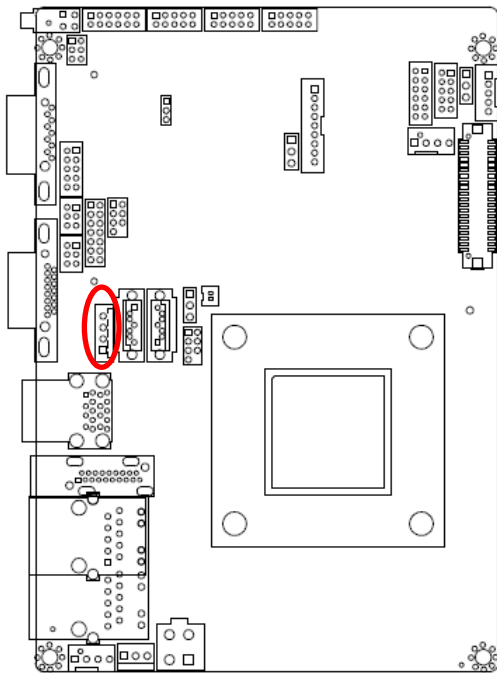

Signal	PIN
+5V	4
+5V	3
GND	2
GND	1

2.3.21 Touch connector (JTOUCH1) (option)

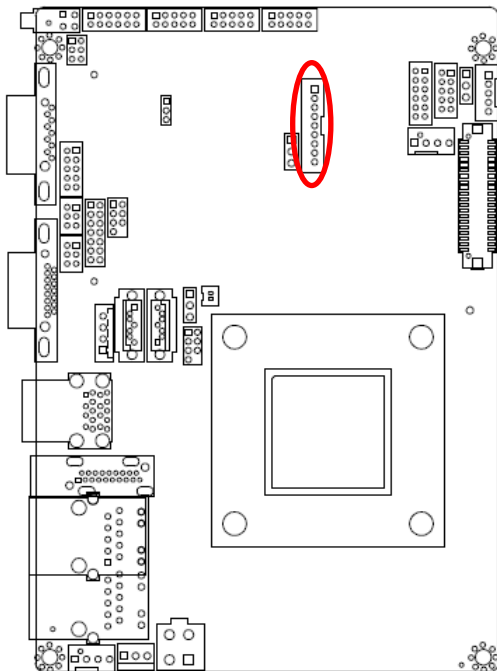

PIN	Signal	4-WIRE	5-WIRE	8-WIRE
1	X+	NC	NC	Right Sense
2	X-	NC	NC	Left Sense
3	Y+	NC	NC	Bottom Sense
4	SENSE	NC	Sense	Top Sense
5	X+	Right	LR	Right Excite
6	X-	Left	LL	Left Excite
7	Y+	Bottom	UR	Bottom Excite
8	Y-	Top	UL	Top Excite
9	GND	GND	GND	GND

ECM-KA Quick Installation Guide

2.3.22 LVDS connector (JLVDS1)

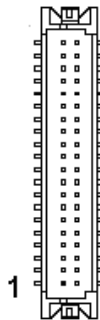
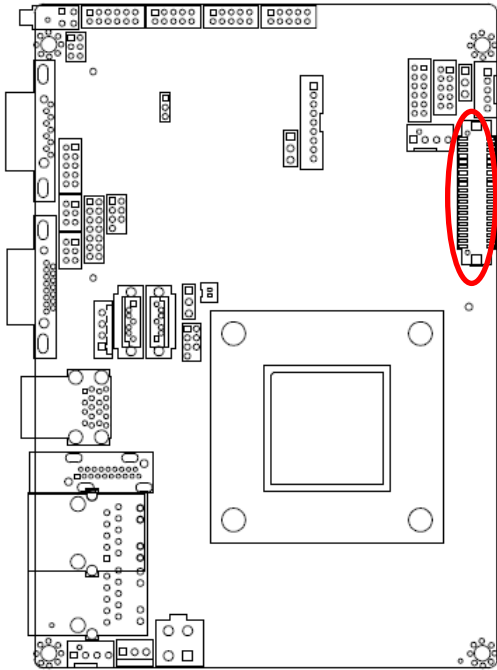

Signal	PIN	PIN	Signal
+12V	39	40	+12V
GND	37	38	GND
LVDS_CLK2_N	35	36	LVDS_CLK1_N
LVDS_CLK2_P	33	34	LVDS_CLK1_P
GND	31	32	GND
LVDS_DATA7_N	29	30	LVDS_DATA6_N
LVDS_DATA7_P	27	28	LVDS_DATA6_P
GND	25	26	GND
LVDS_DATA5_N	23	24	LVDS_DATA4_N
LVDS_DATA5_P	21	22	LVDS_DATA4_P
GND	19	20	GND
LVDS_DATA3_N	17	18	LVDS_DATA2_N
LVDS_DATA3_P	15	16	LVDS_DATA2_P
GND	13	14	GND
LVDS_DATA1_N	11	12	LVDS_DATA0_N
LVDS_DATA1_P	9	10	LVDS_DATA0_P
GND	7	8	GND
NC	5	6	NC
+3.3V	3	4	+5V
+3.3V	1	2	+5V

ECM-KA Quick Installation Guide

2.3.23 On-board box header for USB2.0 (JUSB1)

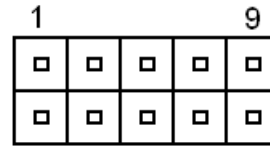
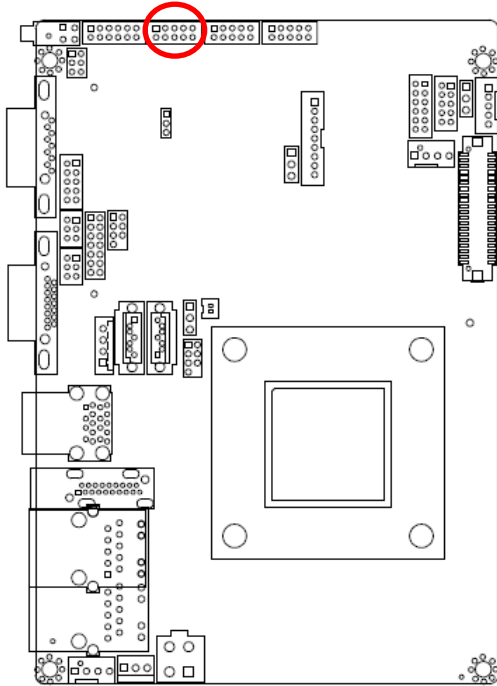

Signal	PIN	PIN	Signal
+5V	1	2	+5V
USB_PN_Z_1	3	4	USB_PN_Z_0
USB_PP_Z_1	5	6	USB_PP_Z_0
GND	7	8	GND
GND	9	10	GND

2.3.24 On-board box header for USB2.0 (JUSB2)

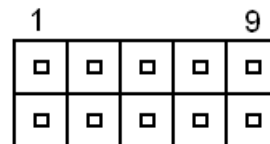
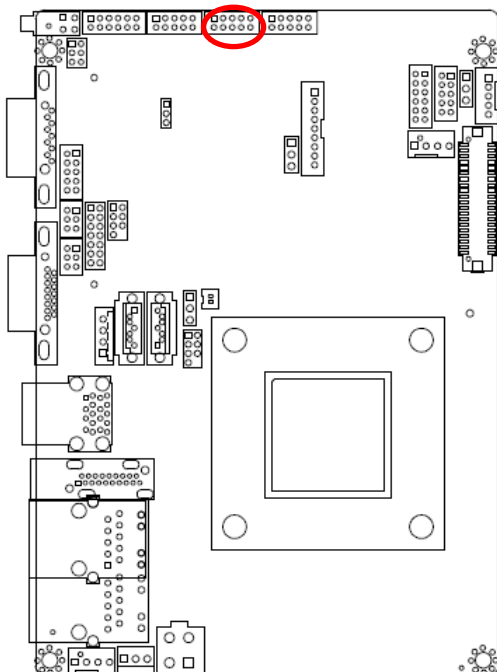

Signal	PIN	PIN	Signal
+5V	1	2	+5V
USB_PN_Z_2	3	4	USB_PN_Z_3
USB_PP_Z_2	5	6	USB_PP_Z_3
GND	7	8	GND
GND	9	10	GND

ECM-KA Quick Installation Guide

2.3.25 On-board box header for USB2.0 (JUSB3)

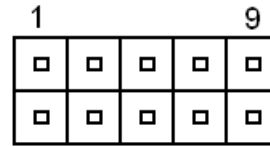
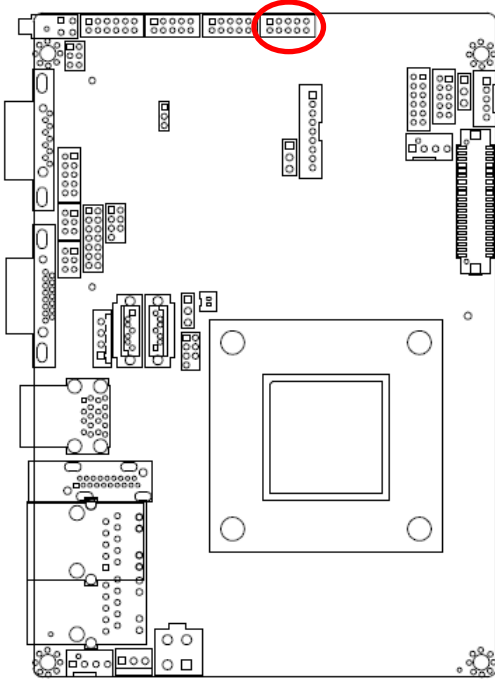

Signal	PIN	PIN	Signal
+5V	1	2	+5V
USB_PN_Z_4	3	4	USB_PN_Z_5
USB_PP_Z_4	5	6	USB_PP_Z_5
GND	7	8	GND
GND	9	10	GND

2.3.26 PS/2 keyboard & mouse connector (JKBMS)

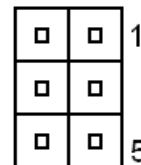
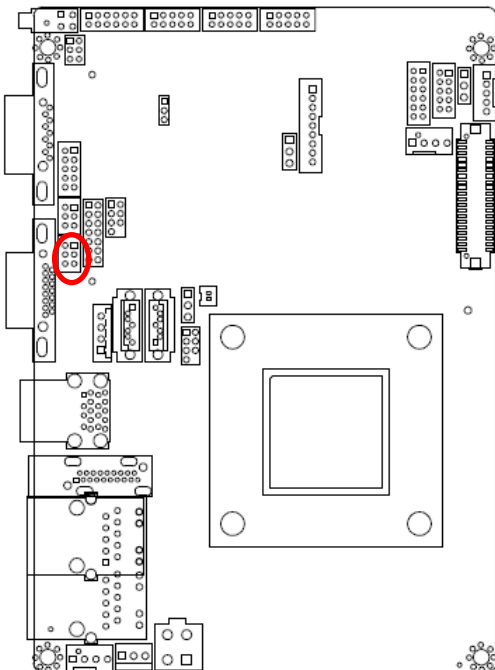

Signal	PIN	PIN	Signal
KBDT	2	1	KBCK
GND	4	3	KBVCC
MSDT	6	5	MSCK

