



2Mx32 FLASH MODULE

DESCRIPTION

The EDI7F342MC and EDI7F2342MC are organized as one and two banks of 2Mx32 respectively. The modules are based on Intel's E28F016S5 2Mx8 Flash device in TSOP packages which are mounted on an FR4 substrate

Both modules offer access times between 90 and 150ns allowing for operation of high-speed microprocessors without wait states.

FEATURES

- 2Mx32 and 2x2Mx32 Densities
- Based on Intel's E28F016S5 Flash Device
- Fast Read Access Time - 90ns
- 5V - Only Reprogramming
- 12V VPP Production Programming
- Low Power Dissipation
 - 35mA per Device Active Write Current
 - 25µA per Device CMOS Standby Current
- Typical Endurance >100,000 Cycles
- Single 5V ± 10% Supply
- CMOS and TTL Compatible Inputs and Outputs
- Commercial and Industrial Temperature Range
- Package
 - 80 pin SIMM (JEDEC)

FIG. 1

BLOCK DIAGRAMS

EDI7F342MC-BNC: 2Mx32 80 PIN SIMM

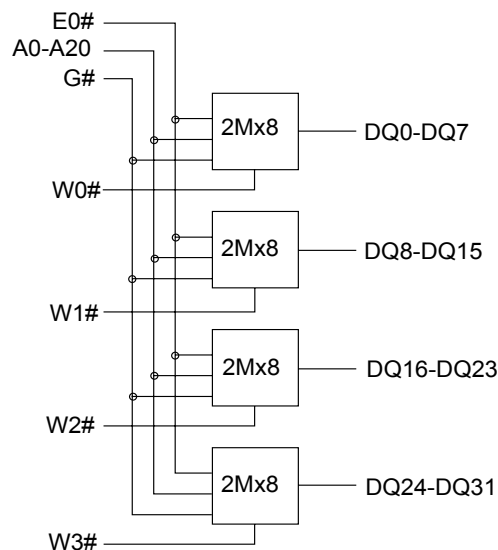

EDI7F2342MC-BNC: 2x2Mx32 80 PIN SIMM

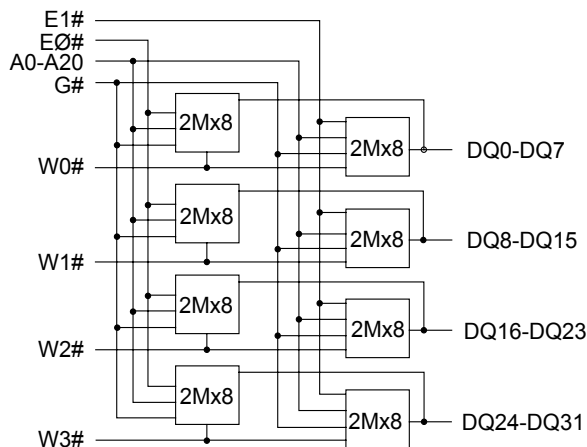



CAPACITANCE

(TA = 25°C, f = 1MHz, Vcc = 2.5V)

		2Meg	2x2Meg	
Parameter	Sym	Max	Max	Unit
Address Lines	CA	35	70	pF
Data lines	CDQ	15	30	pF
Chip Enable Lines	CE	40	40	pF
Write Enable Lines	CW	20	20	pF
Output Enable lines	CG	40	80	pF

Pin Configurations

Pin #	Pin Name	Pin #	Pin Name	Pin #	Pin Name	Pin #	Pin Name
1	Vss	21	*	41	A11	61	DQ9
2	Vcc	22	*	42	A10	62	DQ8
3	VPP	23	*	43	A9	63	DQ7
4	G#	24	*	44	A8	64	DQ6
5	W0#	25	Vss	45	A7	65	DQ5
6	W1#	26	DQ29	46	A6	66	DQ4
7	NC	27	DQ30	47	A5	67	DQ3
8	DQ16	28	DQ31	48	A4	68	DQ2
9	DQ17	29	W2#	49	A3	69	DQ1
10	DQ18	30	NC	50	A2	70	DQ0
11	DQ19	31	NC	51	A1	71	VPP
12	DQ20	32	A20	52	AO	72	Vcc
13	DQ21	33	A19	53	W3#	73	PD1
14	DQ22	34	A18	54	Vss	74	PD2
15	DQ23	35	A17	55	DQ15	75	PD3
16	DQ24	36	A16	56	DQ14	76	PD4
17	DQ25	37	A15	57	DQ13	77	PD5
18	DQ26	38	A14	58	DQ12	78	PD6
19	DQ27	39	A13	59	DQ11	79	PD7
20	DQ28	40	A12	60	DQ10	80	Vss

*TBD

SIMM Density		
Pin	2Meg	2x2Meg
21	NC	NC
22	NC	NC
23	NC	E1#
24	E0#	EO#

Presence Detect Pin Out		
Pin	2Meg	2x2Meg
PD1	Vss	NC
PD2	NC	Vss
PD3	Vss	Vss
PD4	Vss	Vss

- A0-A20 Address input
- E0#, E1# Chip Enable
- W0#-W3# Write Enable
- G# Output Enable
- DQ0-DQ31 Data Input/Output
- P_D Presence Detect
- V_{cc} Power 5V ± 10%
- V_{ss} Ground
- NC No Connect
- VPP Program Power



Ordering Information

Part Number	Speed (ns)	Package
EDI7F342MC90BNC	90	364
EDI7F342MC100BNC	100	364
EDI7F342MC120BNC	120	364
EDI7F342MC150BNC	150	364

Package No. 364: 80 PIN SIMM (JEDEC)

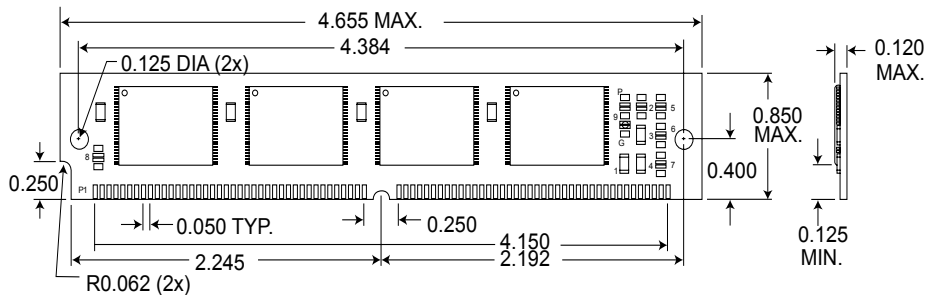

Ordering Information

Part Number	Speed (ns)	Package
EDI7F2342MC90BNC	90	365
EDI7F2342MC100BNC	100	365
EDI7F2342MC120BNC	120	365
EDI7F2342MC150BNC	150	365

Package No. 365: 80 PIN SIMM (JEDEC)

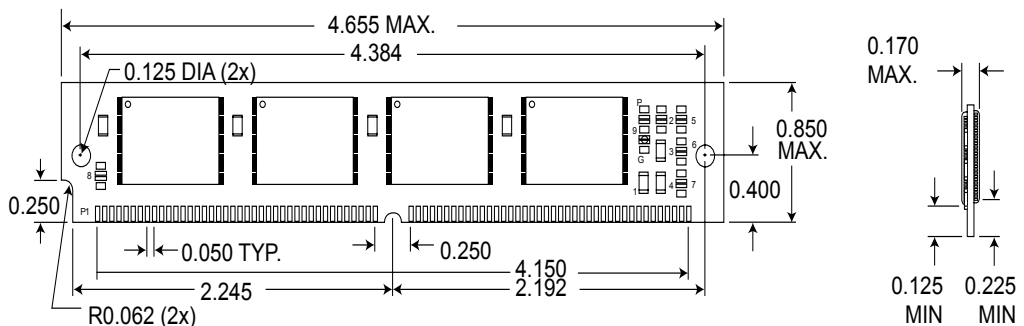

ALL DIMENSIONS ARE IN INCHES