



4x2Mx32 FLASH MODULE

FEATURES

- 4x2Mx32
- Based on Sharp's LH28F016SU Flash Device
- Fast Read Access Time - 80ns
- 5V Only Reprogramming
- Low Power Dissipation
 - 60mA per Device Active Current
 - 10 μ A per Device CMOS Standby Current
- Typical Endurance >100,000 Cycles
- Single 5V \pm 10% Supply
- CMOS and TTL Compatible Inputs and Outputs
- Commercial and Industrial Temperature Range
- Package
 - 80 Pin SIMM (JEDEC)

DESCRIPTION

The EDI7F4342MC is organized as four banks of 2Mx32. The module is based on Sharp's LH28F016SU - 2Mx8 Flash device in TSOP packages which are mounted on an FR4 substrate.

The module offers access times between 80 and 150ns allowing for operation of high-speed microprocessors without wait states.

*This product is subject to change without notice.



**FIG. 1
BLOCK DIAGRAM**

EDI7F4342MC-BNC: 4x2Mx32 80 PIN SIMM

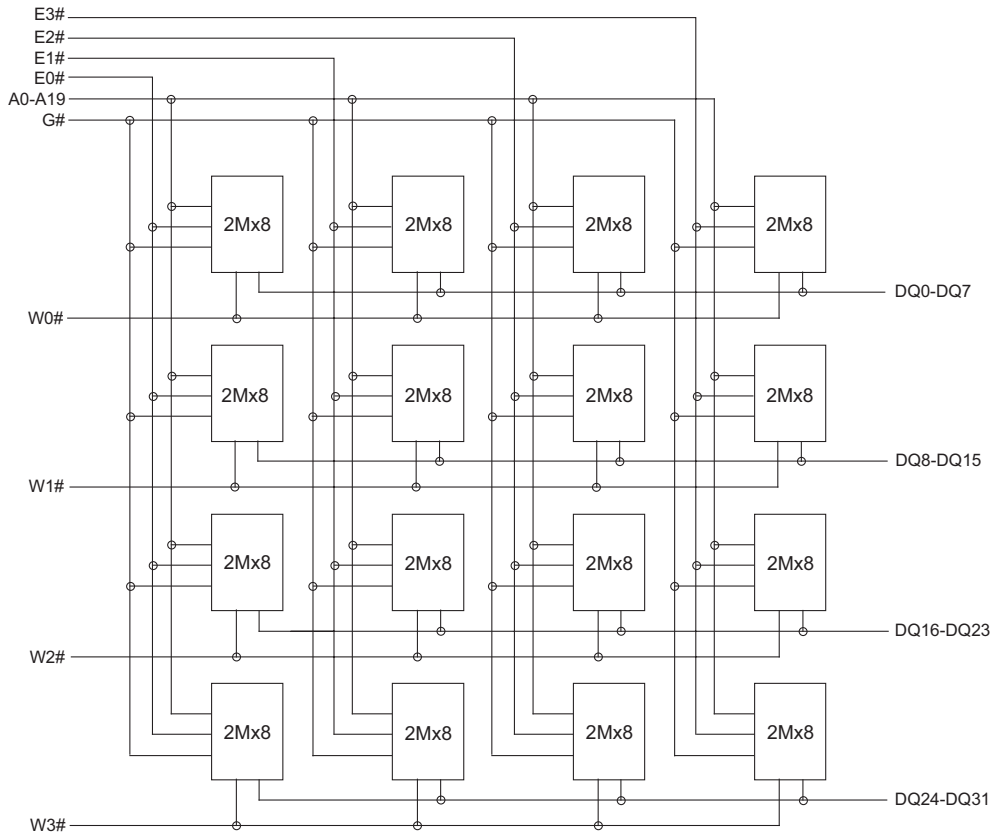



CAPACITANCE

(f=1.0MHz, V_{IN} = V_{CC} or V_{SS})

Parameter	Sym	4x2Meg	
		Max	Unit
Address Lines	CA	140	pF
Data lines	CDQ	60	pF
Chip & Write Enable Lines	CC	60	pF
Output Enable lines	CG	140	pF

PIN CONFIGURATIONS

Pin	Name	Pin	Name	Pin	Name	Pin	Name
1	V _{SS}	21	E3#	41	A11	61	DQ9
2	V _{CC}	22	E2#	42	A10	62	DQ8
3	NC	23	E1#	43	A9	63	DQ7
4	G#	24	E0#	44	A8	64	DQ6
5	W0#	25	V _{SS}	45	A7	65	DQ5
6	W1#	26	DQ29	46	A6	66	DQ4
7	NC	27	DQ30	47	A5	67	DQ3
8	DQ16	28	DQ31	48	A4	68	DQ2
9	DQ17	29	W2#	49	A3	69	DQ1
10	DQ18	30	NC	50	A2	70	DQ0
11	DQ19	31	NC	51	A1	71	NC
12	DQ20	32	NC	52	AO	72	V _{CC}
13	DQ21	33	A19	53	W3#	73	PD1
14	DQ22	34	A18	54	V _{SS}	74	PD2
15	DQ23	35	A17	55	DQ15	75	PD3
16	DQ24	36	A16	56	DQ14	76	PD4
17	DQ25	37	A15	57	DQ13	77	PD5
18	DQ26	38	A14	58	DQ12	78	PD6
19	DQ27	39	A13	59	DQ11	79	PD7
20	DQ28	40	A12	60	DQ10	80	V _{SS}

Presence Detect Pin Out	
Pin	4X2Meg
PD1	V _{SS}
PD2	V _{SS}
PD3	V _{SS}
PD4	V _{SS}

A0-A19	Address Input
E0#,E1#,E2#,E3#	Chip Enable
W0#-W3#	Write Enable
G#	Output Enable
DQ0-DQ31	Data Input/Output
P _D	Presence Detect
V _{CC}	Power 5V±10%
V _{SS}	Ground
NC	No Connect



ORDERING INFORMATION

Part Number	Speed (ns)	Package
EDI7F4342MC80BNC	80	394
EDI7F4342MC90BNC	90	394
EDI7F4342MC100BNC	100	394
EDI7F4342MC120BNC	120	394

PACKAGE NO. 394: 80 PIN SIMM (JEDEC)

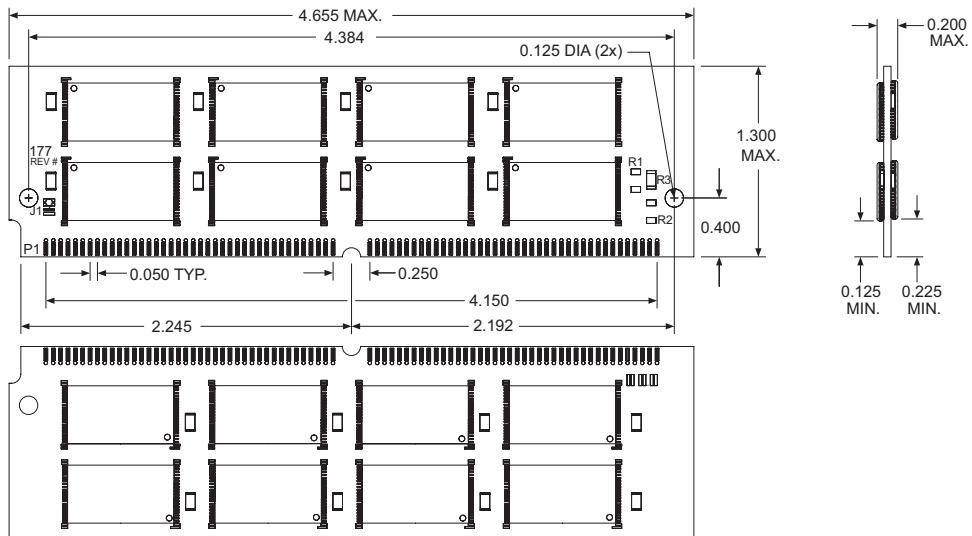

ALL DIMENSIONS ARE IN INCHES