

128Kx8 Static RAM CMOS, Module

The EDI8F8128C* is a 1024K bit CMOS Static RAM based on four 32Kx8 Static RAMs in leadless chip carriers mounted on a multi-layered epoxy laminate (FR-4) substrate.

An on-board decoder circuit interprets the higher order address to select one of the 32Kx8 Static RAMs.

All inputs and outputs are TTL compatible and operate from a single 5V supply. Fully asynchronous, the EDI8F8128C requires no clocks or refreshing for operation.

Features

128Kx8 bit CMOS Static Random Access Memory

- Access Times 30 thru 150ns
- \bar{E} , S^* , and G Functions for Bus Control
- TTL Compatible Inputs and Outputs
- Fully Static, No Clocks

Jedec Approved Pinout

- 600 mil wide, 32 pin DIP Module, No. 112
- 400 mil wide, 32 pin DIP Module, No. 113

Single +5V ($\pm 10\%$) Supply Operation

Pin Configuration and Block Diagram

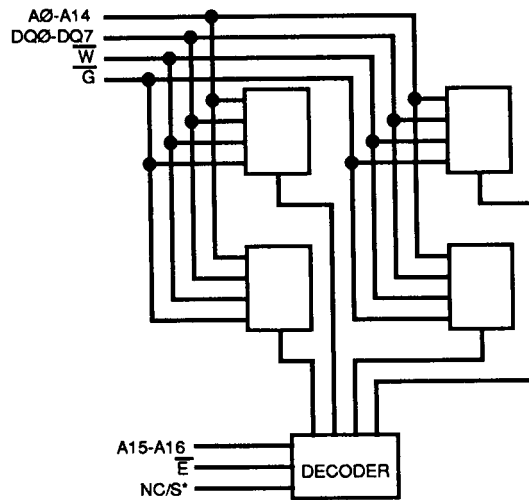
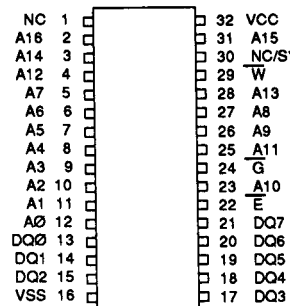

Pin Names

A0-A16	Address Inputs
\bar{E}	Chip Enable
S^*	Chip Select
\bar{W}	Write Enable
\bar{G}	Output Enable
DQ0-DQ7	Common Data Input/Output
VCC	Power (+5V $\pm 10\%$)
VSS	Ground
NC	No Connection

*EDI8F8130C is identical to the EDI8F8128C, with an additional chip select line (S). This additional chip select line can be used to provide system memory security during power down in non-battery backed up systems and to simplify decoding schemes in memory banking where large multiple pages of memory are required.

Absolute Maximum Ratings*

Voltage on any pin relative to VSS -0.5V to 7.0V
 Operating Temperature TA (Ambient)
 Commercial 0°C to +70°C
 Industrial -40°C to +85°C
 Storage Temperature
 Plastic -55°C to +125°C
 Power Dissipation 1 Watt
 Output Current 20 mA

*Stress greater than those listed under "Absolute Maximum Ratings" may cause permanent damage to the device. This is a stress rating only and functional operation of the device at these or any other conditions greater than those indicated in the operational sections of this specification is not implied. Exposure to absolute maximum rating conditions for extended periods may affect reliability.

Recommended DC Operating Conditions

Parameter	Sym	Min	Typ	Max	Units
Supply Voltage	VCC	4.5	5.0	5.5	V
Supply Voltage	VSS	0	0	0	V
Input High Voltage	VIH	2.2	--	6.0	V
Input Low Voltage	VIL	-0.3	--	0.8	V

AC Test Conditions

Input Pulse Levels VSS to 3.0V
 Input Rise and Fall Times 5ns
 Input and Output Timing Levels 1.5V
 Output Load 35-70ns 1TTL, CL = 30pF
 100-150ns 1TTL, CL = 100pF
 (note: For TEHQZ, TGHQZ and TWLQZ, CL = 5pF)

DC Electrical Characteristics

Parameter	Sym	Conditions	Min	Typ*	Max	Units
Operating Power Supply Current	ICC1	$\overline{W}, \overline{E} = \text{VIL}, I/O = 0\text{mA}, \text{Min Cycle}$	--	70	220	mA
Standby (TTL) Power Supply Current	ICC2	$\overline{E} \geq \text{VIH}, \text{VIN} \leq \text{VIL} \text{ or } \geq \text{VIH}$	--	10	130	mA
Full Standby Power Supply Current	ICC3	$\overline{E} \geq \text{VCC}-0.2\text{V}$ $\text{VIN} \geq \text{VCC}-0.2\text{V} \text{ or } \text{VIN} \leq 0.2\text{V}$	--	1	20	mA
Input Leakage Current	ILI	$\text{VIN} = 0\text{V to VCC}$	--	--	±10	µA
Output Leakage Current	ILO	$\text{V I/O} = 0\text{V to VCC}$	--	--	±10	µA
Output High Voltage	VOH	$\text{IOH} = -4.0\text{mA}$	2.4	--	--	V
Output Low Voltage	VOL	$\text{IOL} = 8.0\text{mA}$	--	--	0.4	V

*Typical: TA = 25°C, VCC = 5.0V

Truth Table

\overline{G}	\overline{E}	\overline{W}	Mode	Output	Power
X	H	X	Standby	High Z	ICC2, ICC3
H	L	H	Output Deselect	High Z	ICC1
L	L	H	Read	DOUT	ICC1
X	L	L	Write	DIN	ICC1

Capacitance

(f=1.0MHz, VIN=VCC or VSS)

Parameter	Sym	Max	Unit
Input Capacitance (Except DQ Pins)	CI	25	pF
Capacitance Control (DQ Pins)	CD/Q	40	pF
Input Capacitance Control Lines (\overline{E})	CC	30	pF
Input Capacitance \overline{W} Line	CW	30	pF

These parameters are sampled, not 100% tested.

AC Characteristics
Read Cycle

Parameter	Symbol	30ns		35ns		45ns		55ns		Units
		Min	Max	Min	Max	Min	Max	Min	Max	
Read Cycle Time	TAVAV	30		35		45		55		ns
Address Access Time	TAVQV		30		35		45		55	ns
Chip Enable Access Time	TELQV		30		35		45		55	ns
Chip Enable to Output in Low Z (1)	TELQX	5		5		5		5		ns
Output Enable to Output Valid	TGLQV		20		25		35		40	ns
Output Enable to Output in Low Z (1)	TGLQX	3		3		3		3		ns
Chip Disable to Output in High Z (1)	TEHQZ		20		25		35		40	ns
Output Disable to Output in High Z(1)	TGHQZ		15		15		20		25	ns
Output Hold from Address Change	TAVQX	3		3		3		3		ns

Note 1: Parameter guaranteed, but not tested.

Read Cycle 1
W High; G, E Low

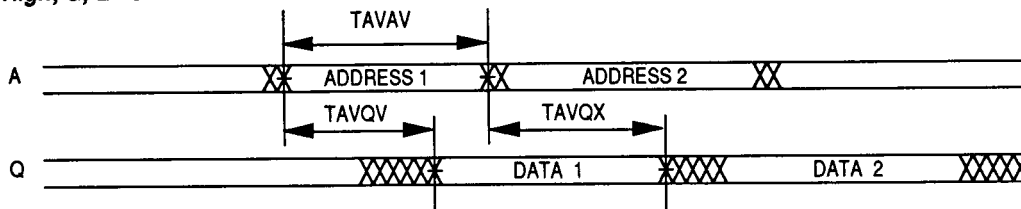

Read Cycle 2
W High

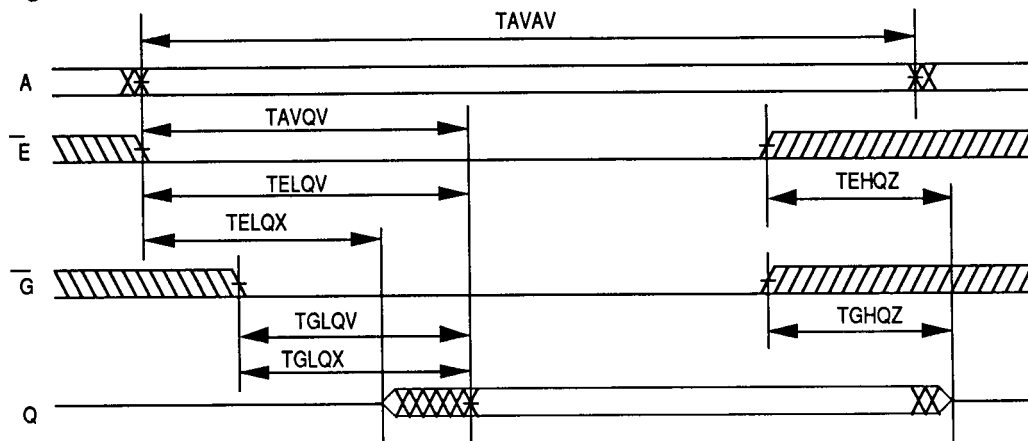

AC Characteristics
Read Cycle

Parameter	Symbol	70ns		100ns		120ns		150ns		Units
		Min	Max	Min	Max	Min	Max	Min	Max	
Read Cycle Time	TAVAV	70		100		120		150		ns
Address Access Time	TAVQV		70		100		120		150	ns
Chip Enable Access Time	TELQV		70		100		120		150	ns
Chip Enable to Output in Low Z (1)	TELQX	5		5		5		5		ns
Output Enable to Output Valid	TGLQV		50		50		60		70	ns
Output Enable to Output in Low Z (1)	TGLQX	10		10		5		5		ns
Chip Disable to Output in High Z (1)	TEHQZ		30		30		40		50	ns
Output Disable to Output in High Z(1)	TGHQZ		30		30		40		50	ns
Output Hold from Address Change	TAVQX	10		10		10		10		ns

Note 1: Parameter guaranteed, but not tested.

AC Characteristics
Write Cycle

Parameter	Symbol		30ns		35ns		45ns		55ns		Units
			Min	Max	Min	Max	Min	Max	Min	Max	
Write Cycle Time	TAVAV		30		35		45		55		ns
Chip Enable to	TELWH	\overline{W}	25		30		40		50		ns
End of Write	TWLEH	\overline{E}	20		25		30		35		ns
Address Setup Time	TAVWL	\overline{W}	0		0		0		0		ns
	TAVEL	\overline{E}	0		0		0		0		ns
Address Valid to	TAVWH	\overline{W}	25		30		40		50		ns
End of Write	TAVEH	\overline{E}	25		30		40		50		ns
Write Pulse Width	TWLWH	\overline{W}	20		25		30		35		ns
	TELEH	\overline{E}	25		30		40		50		ns
Write Recovery Time	TWHAX	\overline{W}	0		0		0		0		ns
	TEHAX	\overline{E}	20		20		20		20		ns
Data Hold Time	TWHDX	\overline{W}	0		0		0		0		ns
	TEHDX	\overline{E}	20		20		20		20		ns
Write to Output in High Z (1)	TWLQZ			12		15		20		25	ns
Data to Write Time	TDVWH	\overline{W}	15		20		20		25		ns
	TDVEH	\overline{E}	15		20		20		25		ns
Output Active from End of Write (1)	TWHQX		0		0		0		0		ns

Note 1: Parameter guaranteed, but not tested.

AC Characteristics
Write Cycle

Parameter	Symbol		70ns		100ns		120ns		150ns		Units
			Min	Max	Min	Max	Min	Max	Min	Max	
Write Cycle Time	TAVAV		70		100		120		150		ns
Chip Enable to	TELWH	\overline{W}	55		80		85		70		ns
End of Write	TWLEH	\overline{E}	55		80		85		70		ns
Address Setup Time	TAVWL	\overline{W}	20		20		20		20		ns
	TAVEL	\overline{E}	0		0		0		0		ns
Address Valid to	TAVWH	\overline{W}	55		80		90		110		ns
End of Write	TAVEH	\overline{E}	60		80		85		90		ns
Write Pulse Width	TWLWH	\overline{W}	60		70		70		80		ns
	TELEH	\overline{E}	55		80		90		110		ns
Write Recovery Time	TWHAX	\overline{W}	0		0		0		0		ns
	TEHAX	\overline{E}	20		20		20		20		ns
Data Hold Time	TWHDX	\overline{W}	0		0		0		0		ns
	TEHDX	\overline{E}	20		20		20		20		ns
Write to Output in High Z (1)	TWLQZ		0	35	0	35	0	35	0	45	ns
Data to Write Time	TDVWH	\overline{W}	25		35		40		50		ns
	TDVEH	\overline{E}	25		35		40		50		ns
Output Active from End of Write (1)	TWHQX		0		0		0		0		ns

Note 1: Parameter guaranteed, but not tested.

**Write Cycle 1
W Controlled**

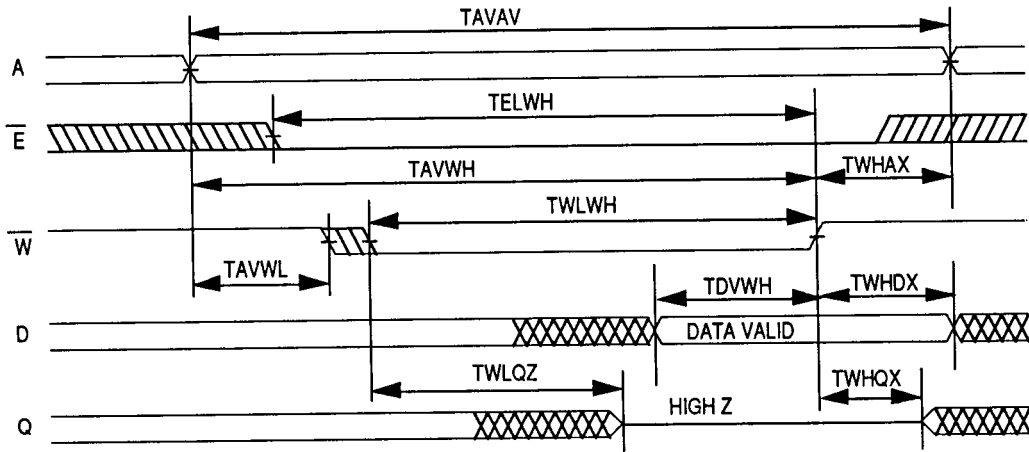

**Write Cycle 2
E Controlled**

