

EF12.6 SERIES POWER TRANSFORMER MODULES

PRODUCT OVERVIEW:THT POWER TRANSFORMERS

Characteristics

High insulation type High efficiency
IEC60950 Compatible
Operating temperature range:-40°C to +85°C

Applications

Lighting
metering
industrial Controls
Charging
White Goods
Telecom
Stand-by Power



Bobbin Winding Area

Width (mm)	Build (mm)	Perimeter (mm)
7.49	1.85	24.6

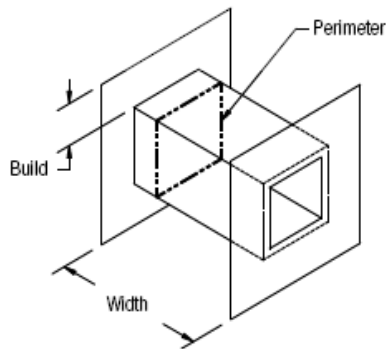

CORE DATA

Ae (mm ²)	Ve (mm ³)	Le (mm)
20.2	559	28

POWER LEVEL (W)

Flyback	Forward	Push-pull
2	3	6

Test frequency:100KHz

THT Horizontal

Dimensions & Footprint

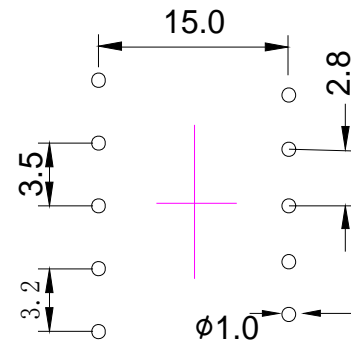
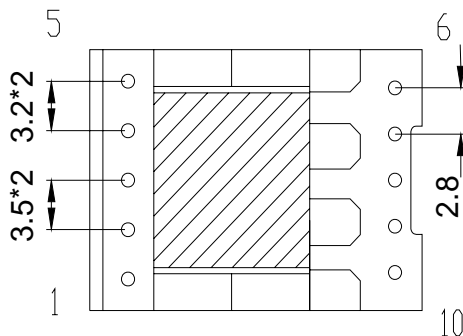
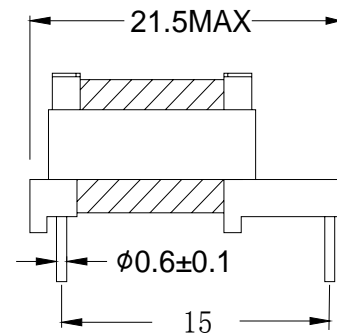
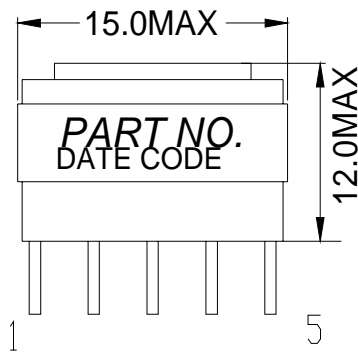

SUGGEST PAD LAYOUT