

## EF25 SERIES POWER TRANSFORMER MODULES

### PRODUCT OVERVIEW: THT POWER TRANSFORMERS

#### Characteristics

High insulation type High efficiency  
 IEC60950 Compatible  
 Operating temperature range: -40°C to +85°C

#### Applications

Lighting  
 metering  
 industrial Controls  
 White Goods  
 Telecom  
 DC/DC Converter



#### Bobbin Winding Area

Width (mm)	Build (mm)	Perimeter (mm)
15.2	4.05	37.2

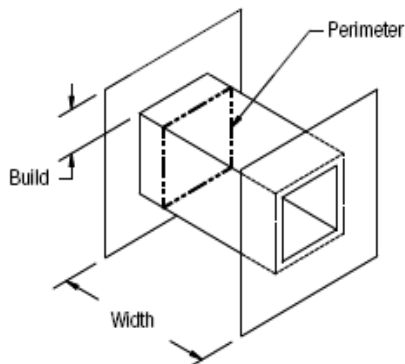

#### CORE DATA

Ae (mm <sup>2</sup> )	Ve (mm <sup>3</sup> )	Le (mm)
51.4	2970	57.8

#### POWER LEVEL (W)

Flyback	Forward	Push-pull
47	71	141

Test frequency: 100KHz

#### THT Horizontal

Dimensions & Footprint

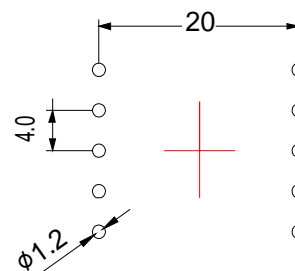
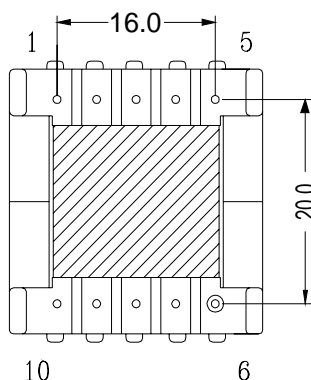
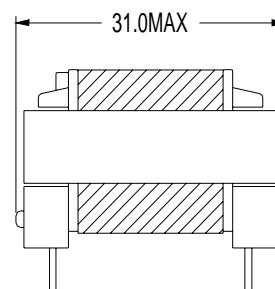
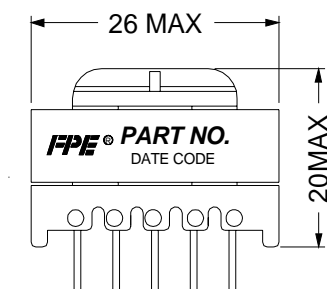

SUGGEST PAD LAYOUT