

EFD15 SERIES POWER TRANSFORMER MODULES

PRODUCT OVERVIEW:THT POWER TRANSFORMERS

Characteristics

Through-hole
Core Direction:horizontal
Functional Insulation

Applications

Lighting
metering
industrial Controls
White Goods
Telecom
DC/DC Converter



Bobbin Winding Area

Width (mm)	Build (mm)	Perimeter (mm)
9.25	1.8	20.8

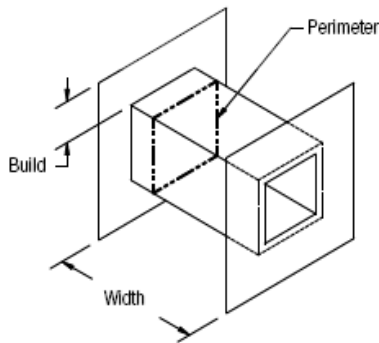

CORE DATA

Ae (mm ²)	Ve (mm ³)	Le (mm)
15	510	34

POWER LEVEL (W)

Flyback	Forward	Push-pull
3	5	9

Test frequency:100KHz

THT Horizontal

Dimensions & Footprint

TYPE1

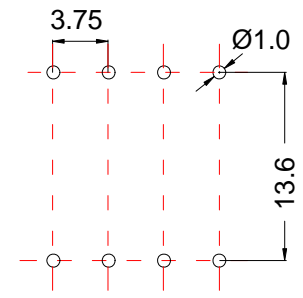
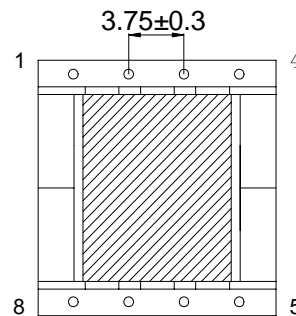
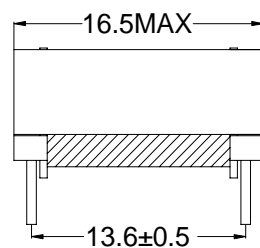
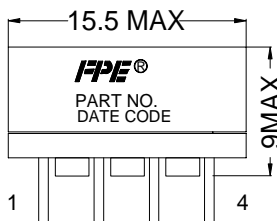

SUGGESTED PAD LAYOUT

TYPE2

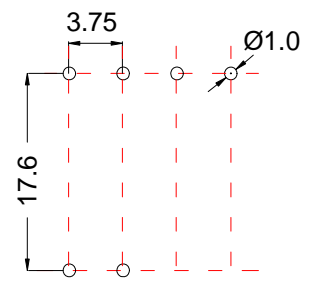
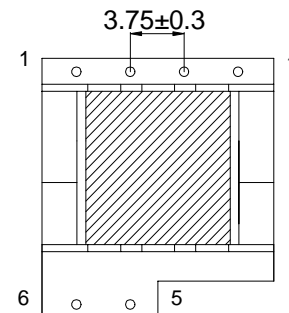
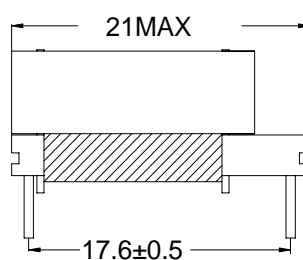
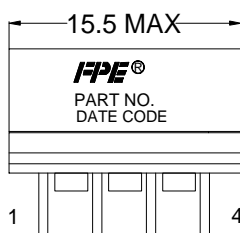

SUGGESTED PAD LAYOUT