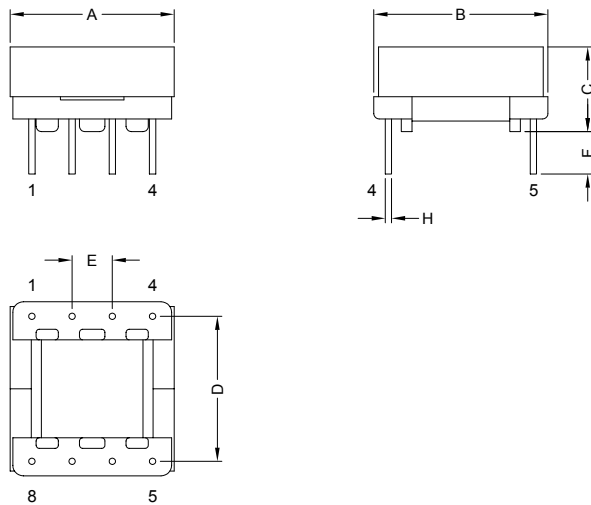
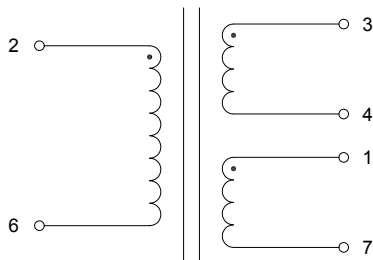

1. CONFIGURATION & DIMENSIONS :

Unit:m/m

A	B	C	D	E	F	H
16.76 Max.	16.76 Max.	8.89 Max.	13.70±0.50	3.80±0.30	4.00±0.50	Ø0.60 Ref.

2. SCHEMATIC :**3. SCHEMATIC :**

- Bobbin : Phenolic
- Core : EFD15
- Wire : Polyurethane (UEW)
- Tape : Polyester Tape
- Varnish : Synthite AC-43

**RoHS Compliant**

NOTE : Specifications subject to change without notice. Please check our website for latest information.

23.06.2008

**SUPERWORLD ELECTRONICS (S) PTE LTD**

PG. 1

4. GENERAL SPECIFICATION :

- a) Operating Temperature Range : -25°C to +105°C
b) Insulation Class : B (130°C)

5. ELECTRICAL CHARACTERISTICS :

Part No.	Inductance (L)	Conditions	Test Frequency	DCR @ 25°C
EFDB5HTF-50733	L : (2-6) = 18uH Min.	-	10KHz 0.1V	(2-6) = 0.77Ω±10%
				(3-4) = 3.08Ω±10%
				(1-7) = 1.55Ω±10%

**RoHS Compliant**

NOTE : Specifications subject to change without notice. Please check our website for latest information.

23.06.2008

**SUPERWORLD ELECTRONICS (S) PTE LTD**

PG. 2