

Data Group: 168

SKU: 1112010

Weight (Kg): 0.1550

Description: EG-530AD-2F

HS Code: 8501.31.6000

Applications: DVD player, Cassette Tape Recorder, Audio and Visual Equipment

	MFG Model	Voltage Range (VDC)	Rated Voltage (VDC)	Rotation	Rated Load		At max efficiency			Starting Torque	
				Direction	g-cm	mN.M	Current (mA)	Speed (RPM)	Torque (g-cm)	g.cm	mN.m
	EG-530AD-6B	4.2-7.5	6	CCW	8	0.78	130	2400	9	38/4.2V	37.2/4.2V
	EG-530AD-6F	4.2-7.5	6	CW	8	0.78	130	2400	9	38/4.2V	37.2/4.2V
	EG-530AD-9B	6.0-11	9	CCW	8	0.78	92	2400	9	50/6.0V	4.90/6.0V
	EG-530AD-9F	6.0-11	9	CW	8	0.78	92	2400	9	50/6.0V	4.90/6.0V
	EG-530AD-2B	8.4-15	12	CCW	8	0.78	73	2400	9	60/8.4V	5.88/8.4V
	EG-530AD-2F	8.4-15	12	CW	8	0.78	73	2400	9	60/8.4V	5.88/8.4V

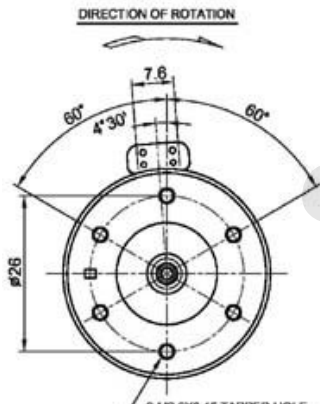

Usable male screw length 1.8 max. from motor mounting surface.

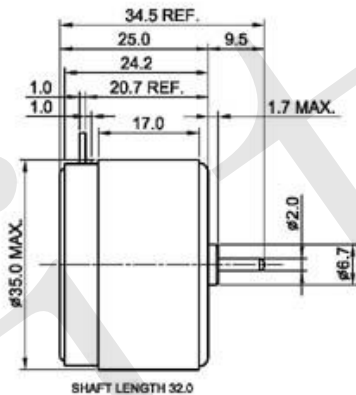

WEIGHT: 70g(APPROX)

